

SPECIFICATIONS

CUSTOMER : PTC
SAMPLE CODE : SH102600T007-IAA01
MASS PRODUCTION CODE : PH102600T007-IAA01
SAMPLE VERSION : 01
SPECIFICATIONS EDITION : 002
DRAWING NO. (Ver.) : JLMD-PH102600T007-IAA01_002
PACKAGING NO. (Ver.) : JPKG-PH102600T007-IAA01_001

Customer Approved

Date:



Approved	Checked	Designer
閔偉	張久慧	劉進

- Preliminary specification for design input
 Specification for sample approval

POWERTIP TECH. CORP.

Headquarters: No.8, 6th Road, Taichung Industrial Park,
Taichung, Taiwan
台中市 407 工業區六路 8 號

TEL: 886-4-2355-8168

FAX: 886-4-2355-8166

E-mail: sales@powertip.com.tw

[Http://www.powertip.com.tw](http://www.powertip.com.tw)

History of Version

Date	Ver.	Edi.	Description	Page	Design by
12/30/2015	01	001	New Drawing	-	劉進
02/22/2016	01	002	New Sample	-	劉進

Total:25 Page

Contents

1. SPECIFICATIONS

- 1.1 Features
- 1.2 Mechanical Specifications
- 1.3 Absolute Maximum Ratings
- 1.4 DC Electrical Characteristics
- 1.5 Optical Characteristics
- 1.6 Backlight Characteristics

2. MODULE STRUCTURE

- 2.1 Counter Drawing
- 2.2 Interface Pin Description
- 2.3 Timing Characteristics

3. QUALITY ASSURANCE SYSTEM

- 3.1 Quality Assurance Flow Chart
- 3.2 Inspection Specification

4. RELIABILITY TEST

- 4.1 Reliability Test Condition

5. PRECAUTION RELATING PRODUCT HANDLING

- 5.1 Safety
- 5.2 Handling
- 5.3 Storage
- 5.4 Terms of Warranty

Appendix : LCM Drawing
Packaging

1. SPECIFICATIONS

1.1 Features

Main LCD Panel

Item	Standard Value
Display Type	1024* (R · G · B) * 600 Dots
Color filter array	RGB vertical stripe
LCD Type	Normally white
Screen size(inch)	10.1(Diagonal)
Viewing Direction	6 o'clock(Gray inversion)
Backlight	White LED
Interface	LVDS
ROHS	THIS PRODUCT CONFORMS THE ROHS OF PTC Detail information please refer website : http://www.powertip.com.tw/news.php?area_id_view=1085560481/

1.2 Mechanical Specifications

Item	Standard Value	Unit
Outline Dimension	235(W) * 143 (L) * 4.5 (H)	mm

LCD panel

Item	Standard Value	Unit
Active Area	222.72 (W) * 125.28 (L)	mm

Note : For detailed information please refer to LCM drawing

1.3 Absolute Maximum Ratings

Item	Symbol	Condition	Min.	Max.	Unit
Digital Supply Voltage	VDD	-	-0.3	+5.0	V
TFT Gate on voltage	VGH	-	-0.3	+40	V
TFT Gate off voltage	VGL	-	-20	0.3	V
Analog power supply voltage	AVDD	-	-0.5	15	V
Operating Temperature	T _{OP}	-	-20	+70	°C
Storage Temperature	T _{ST}	-	-30	+80	°C
Storage Humidity	H _D	T _a < 60 °C	20	90	%RH

1.4 DC Electrical Characteristics

Item	Symbol	Condition	Min.	Typ.	Max.	Unit
Digital Supply Voltage	VDD	-	3.0	3.3	3.6	V
TFT Gate on voltage	VGH	-	20	21	22	V
TFT Gate off voltage	VGL	-	-6.5	-5.5	-4.5	V
TFT Common electrode voltage	VCOM	-	3.7	3.9	4.1	V
Analog power supply voltage	AVDD	-	10.65	10.85	11.05	V
Gate on Current	IVGH	VGH = 21 V	-	0.5	-	mA
Gate off Current	IVGL	VGL = -5.5V	-	4.8	-	mA
Digital Current	IVDD	VDD = 3.3V	-	17.9	-	mA
Analog Current	IAVDD	AVDD = 10.85V	-	29.1	-	mA

1.5 Optical Characteristics

TFT LCD Panel

Ta=25°C

Item	Symbol	Condition	Min.	Typ.	Max.	Unit	-	
Response time	Tr + Tf	-	-	8	-	ms	Note2	
Viewing angle	Top	ΘY+	CR ≥ 10	60	-	Deg.	Note4	
	Bottom	ΘY-		70	-			
	Left	ΘX-		70	-			
	Right	ΘX+		70	-			
Contrast ratio	CR	-	600	-	-	Note3		
Color of CIE Coordinate (With B/L)	White	X	IF=260mA	0.23	0.28	0.33	-	Note1
		Y		0.26	0.31	0.36		
	Red	X		0.56	0.61	0.66		
		Y		0.29	0.34	0.39		
	Green	X		0.27	0.32	0.37		
		Y		0.55	0.60	0.65		
	Blue	X		0.09	0.14	0.19		
		Y		0.06	0.11	0.16		
Average Brightness Pattern=white display (With LCD)*2	IV	IF=260mA	400	450	-	cd/m2	Note1	
Uniformity (With LCD)*1	ΔB	IF= 20mA	70	-	-	%	Note1	

Note1:

1 : $\Delta B = B(\min) / B(\max) \times 100\%$

2 : Measurement Condition for Optical Characteristics:

a : Environment: 25°C ± 5°C / 60 ± 20% R.H , no wind , dark room below 10 Lux at typical lamp current and typical operating frequency.

b : Measurement Distance: 500 ± 50 mm , (θ = 0°)

c : Equipment: TOPCON BM-7 fast , (field 1°) , after 10 minutes operation.

d : The uncertainty of the C.I.E coordinate measurement ± 0.01 , Average Brightness ± 4%

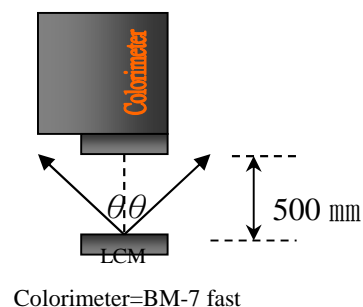

Note2: Definition of response time:

The output signals of photo detector are measured when the input signals are changed from "black" to "white"(falling time) and from "white" to "black"(rising time), respectively. The response time is defined as the time interval between the 10% and 90% of Amplitudes.

Refer to figure as below:

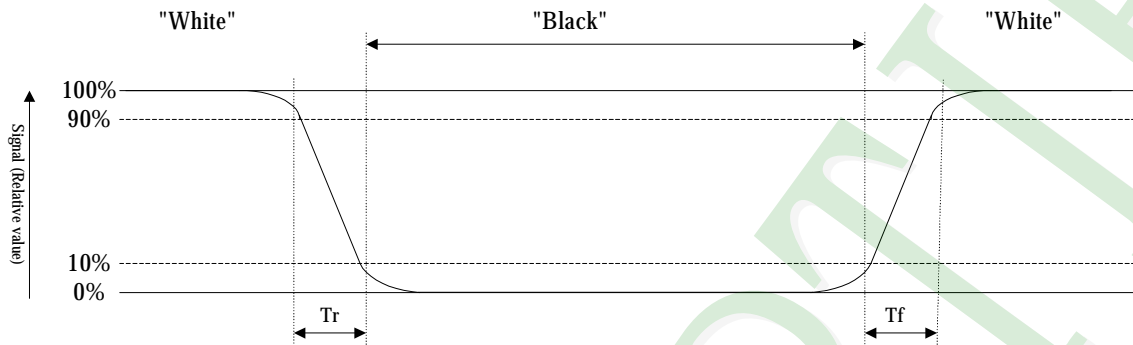

Note3: Definition of contrast ratio:

Contrast ratio is calculated with the following formula

$$\text{Contrast ratio (CR)} = \frac{\text{Photo detector output when LCD is at "White" state}}{\text{Photo detector output when LCD is at "Black" state}}$$

Note4: Definition of viewing angle:

Refer to figure as below:

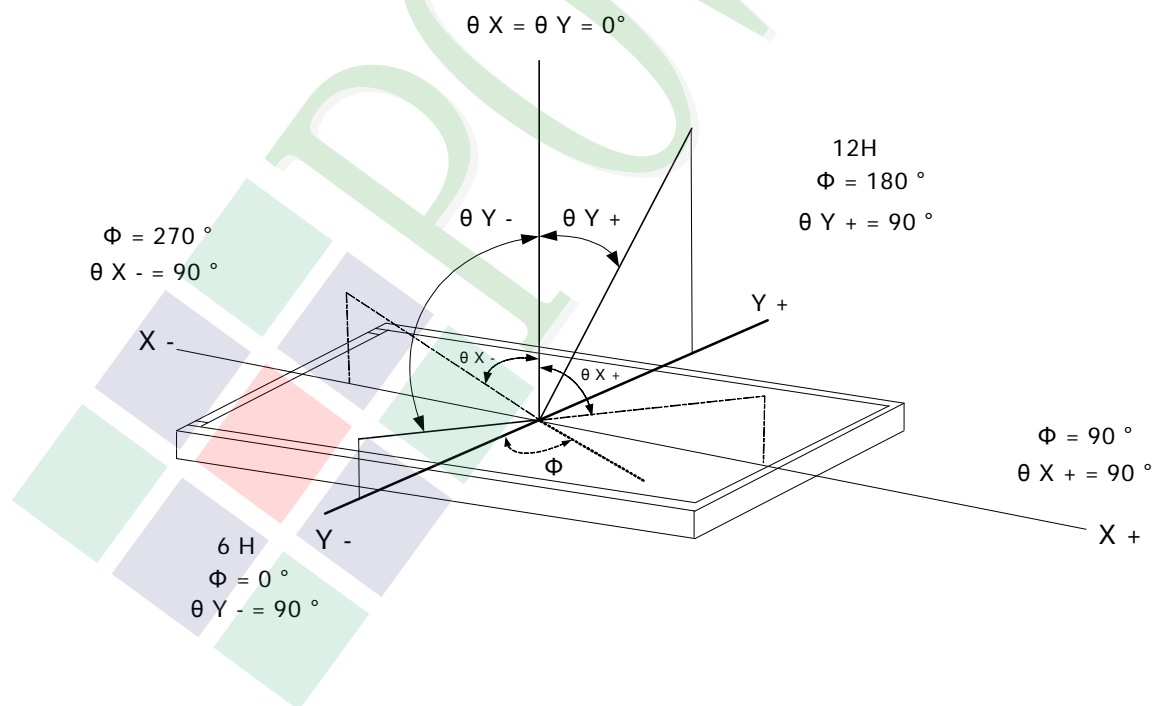

1.6 Backlight Characteristics

Maximum Ratings

Item	Symbol	Conditions	Min.	Typ.	Max.	Unit
Forward voltage	VF	IF=260mA	9.0	9.9	10.5	V
Color	White					

Internal Circuit Diagram:

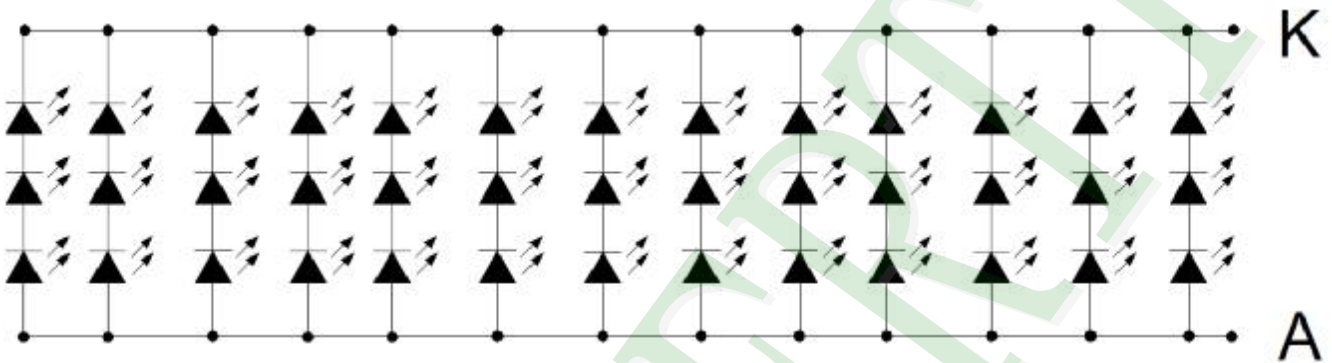

Other Description

Item	Conditions	Description
Life Time	Ta =25°C IF= 260mA	50000 hrs

2. MODULE STRUCTURE

2.1 Counter Drawing

2.1.1 LCM Mechanical Diagram

* See Appendix



2.2 Interface Pin Description

Pin No.	Symbol	Description
1	VCOM	Common voltage
2	VDD	Digital power
3	VDD	Digital power
4	NC	Not connect
5	RESET	Global reset pin. Active low to enter reset state. Suggest to connecting with an RC reset circuit for stability. Normally pull high. (R=100K _Ω , C=1μF)
6	STBYB	Standby mode, normally pull high STBYB="1", normal operation STBYB="0", timing control, source driver will turn off, all output are high-Z
7	GND	Ground
8	RXIN0-	Negative LVDS differential data inputs
9	RXIN0+	Positive LVDS differential data inputs
10	GND	Ground
11	RXIN1-	Negative LVDS differential data inputs
12	RXIN1+	Positive LVDS differential data inputs
13	GND	Ground
14	RXIN2-	Negative LVDS differential data inputs
15	RXIN2+	Positive LVDS differential data inputs
16	GND	Ground
17	RXCLKIN-	Negative LVDS differential clock inputs
18	RXCLKIN+	Positive LVDS differential clock inputs
19	GND	Ground
20	RXIN3-	Negative LVDS differential data inputs

Pin No.	Symbol	Description
21	RXIN3+	Positive LVDS differential data inputs
22	GND	Ground
23	NC	Not connect
24	NC	Not connect
25	GND	Ground
26	NC	Not connect
27	NC	Not connect
28	SELB	6bit/8bit mode select H : 6bit / L : 8bit
29	AVDD	Power for Analog Circuit
30	GND	Ground
31	NC	Not connect
32	NC	Not connect
33	L/R	Horizontal inversion
34	U/D	Vertical inversion
35	VGL	Negative power for TFT
36	GND	Ground
37	GND	Ground
38	VGH	Positive power for TFT
39	NC	Not connect
40	NC	Not connect

Note:

When L/R="0" , set right to left scan direction; When L/R="1" , set left to right scan direction

When U/D="0" , set top to bottom scan direction; When U/D="1" , set bottom to top scan direction

2.3 Timing Characteristics

2.3.1 Power ON/OFF Sequence

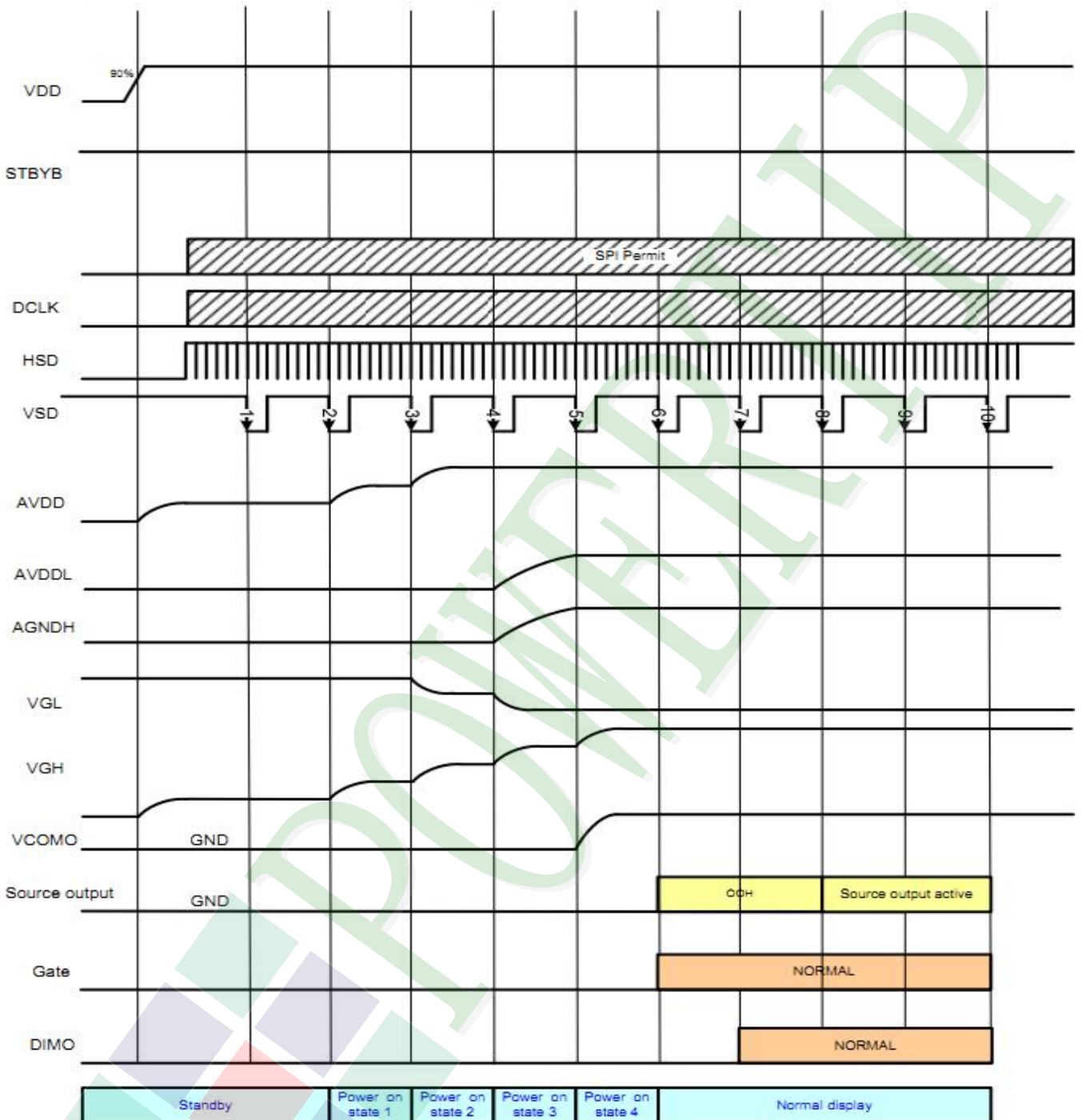

Power on timing sequence

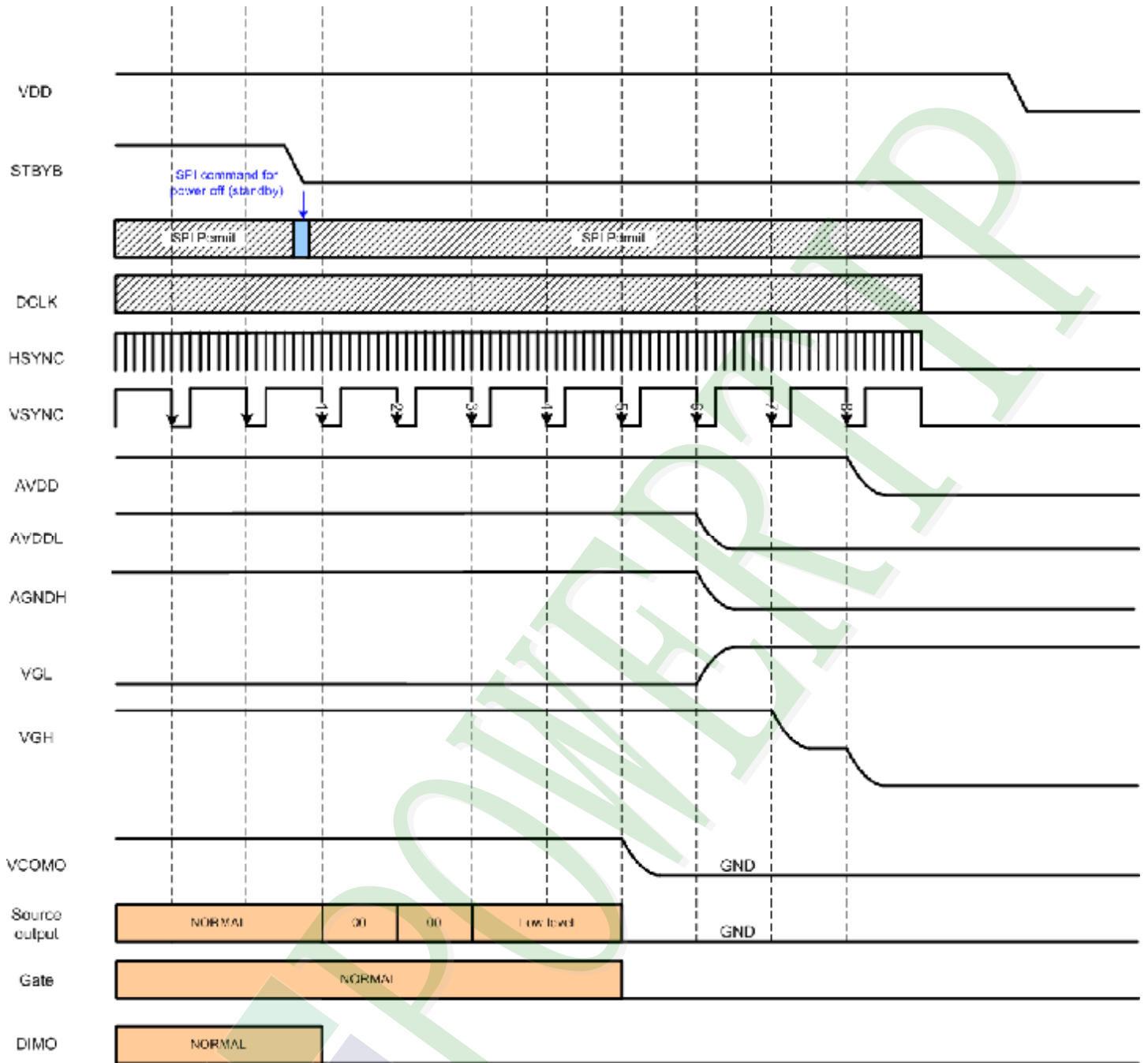

Power off timing sequence

2.3.2 Input Signal Timing

LVDS mode AC electrical characteristics

Parameter	Symbol	Spec.			Unit	Condition
		Min.	Typ.	Max.		
Clock frequency	RXFCLK	20	-	71	MHz	-
Input data skew margin	TRSKM	500	-	-	pS	VID = 400mV RXVCM = 1.2V RXFCLK = 71MHz
Clock high time	TLVCH	-	4 / (7 * RXFCLK)	-	ns	-
Clock low time	TLVCL	-	3 / (7 * RXFCLK)	-	ns	-
PLL wake-up time	TemPLL	-	-	150	µs	-

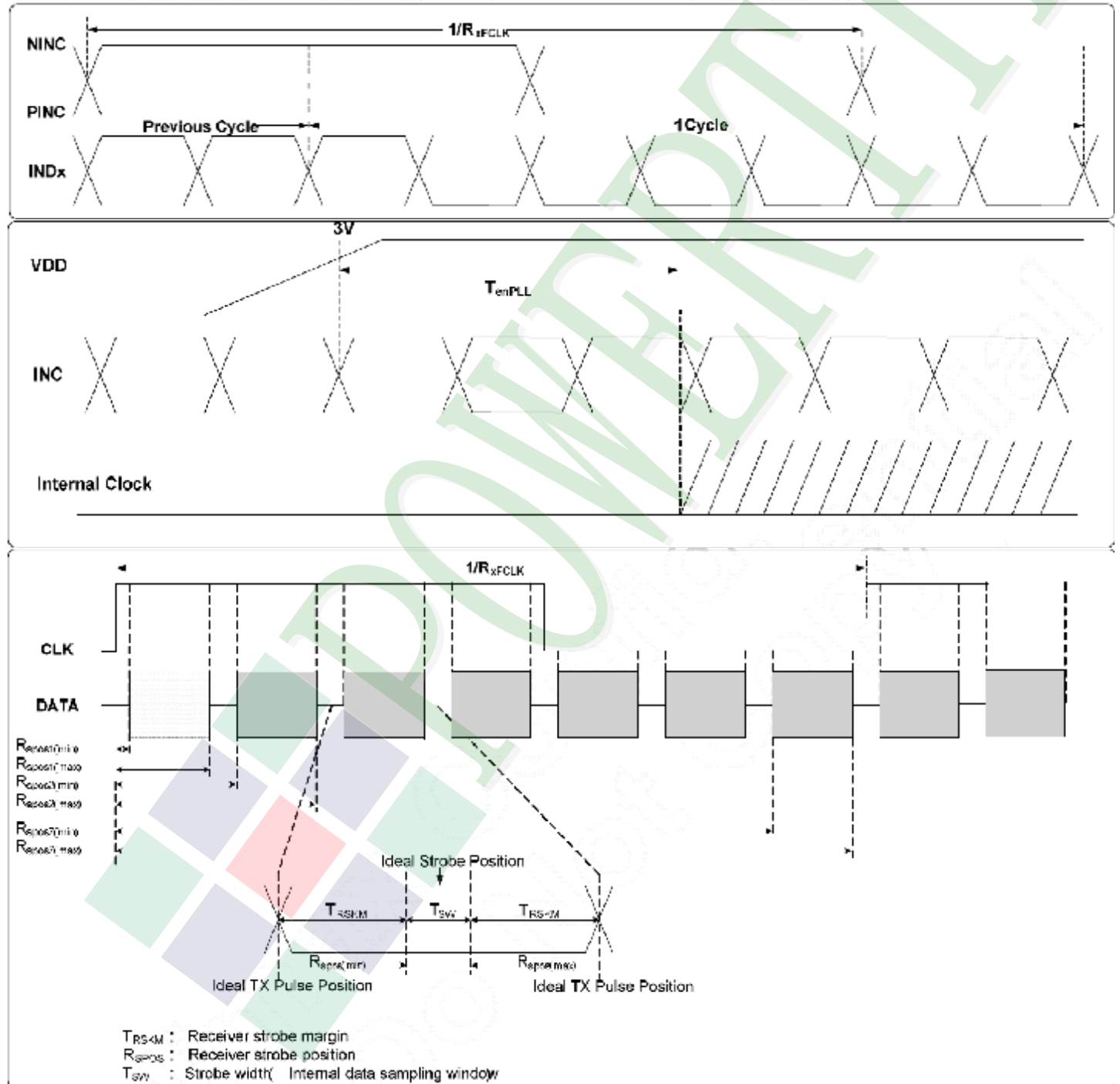

2.3.3 LVDS mode DC electrical characteristics

Parameter	Symbol	Spec.			Unit	Condition
		Min.	Typ.	Max.		
Differential input high Threshold voltage	R_{XVTH}	-	-	+0.1	V	$R_{XVCM}=1.2V$
Differential input low threshold voltage	R_{XVTL}	-0.1	-	-	V	
Input voltage range (singled-end)	R_{XVIN}	0	-	$VDD-1.2+ V_{ID} /2$	V	-
Differential input common Mode voltage	R_{XVCM}	$ V_{ID} /2$	-	$VDD-1.2$	V	-
Differential input voltage	$ V_{ID} $	0.2	-	0.6	V	-
Differential input leakage Current	RV_{Xliz}	-10	-	+10	μA	-
LVDS Digital Operating Current	I_{ddlvds}	-	15	30	mA	$F_{clk}=65MHz, VDD=3.3V$
LVDS Digital Stand-by Current	I_{stlvds}	-	10	50	μA	Clock & all Functions are stopped

LVDS mode DC electrical characteristics

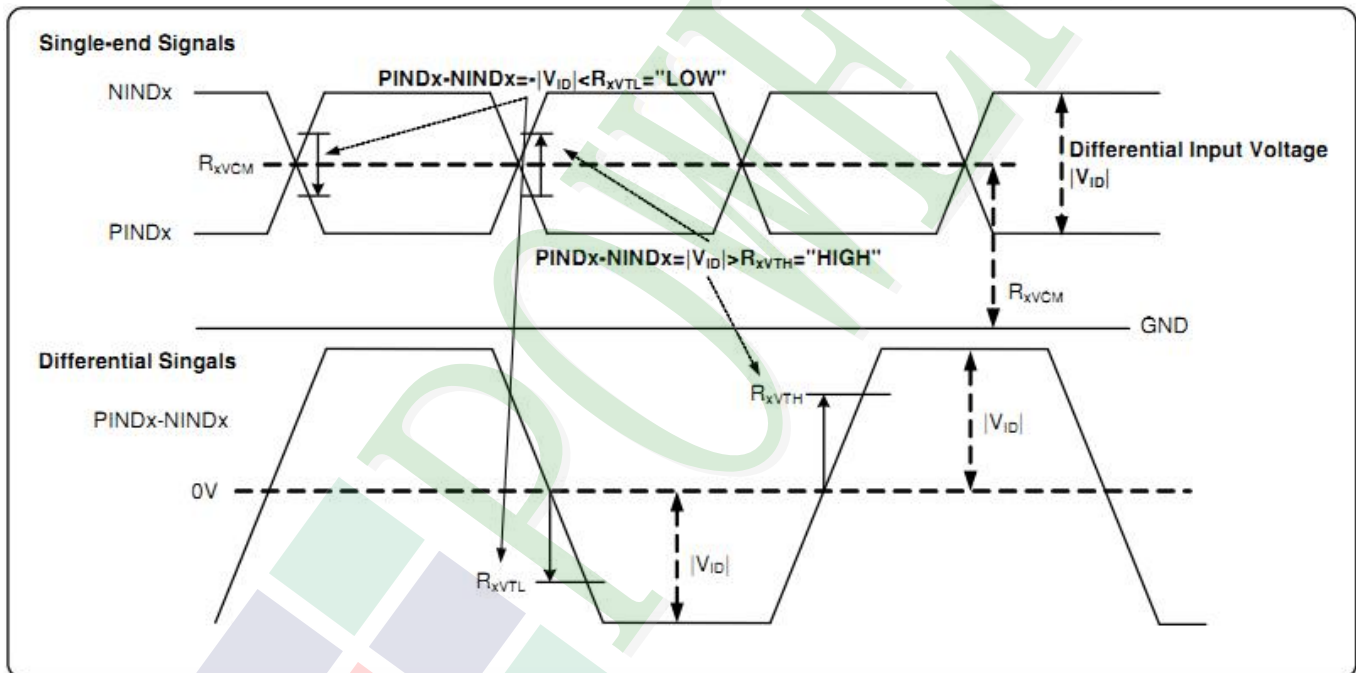

Single-end signals

2.3.4 LVDS mode data input format

6bit LVDS input

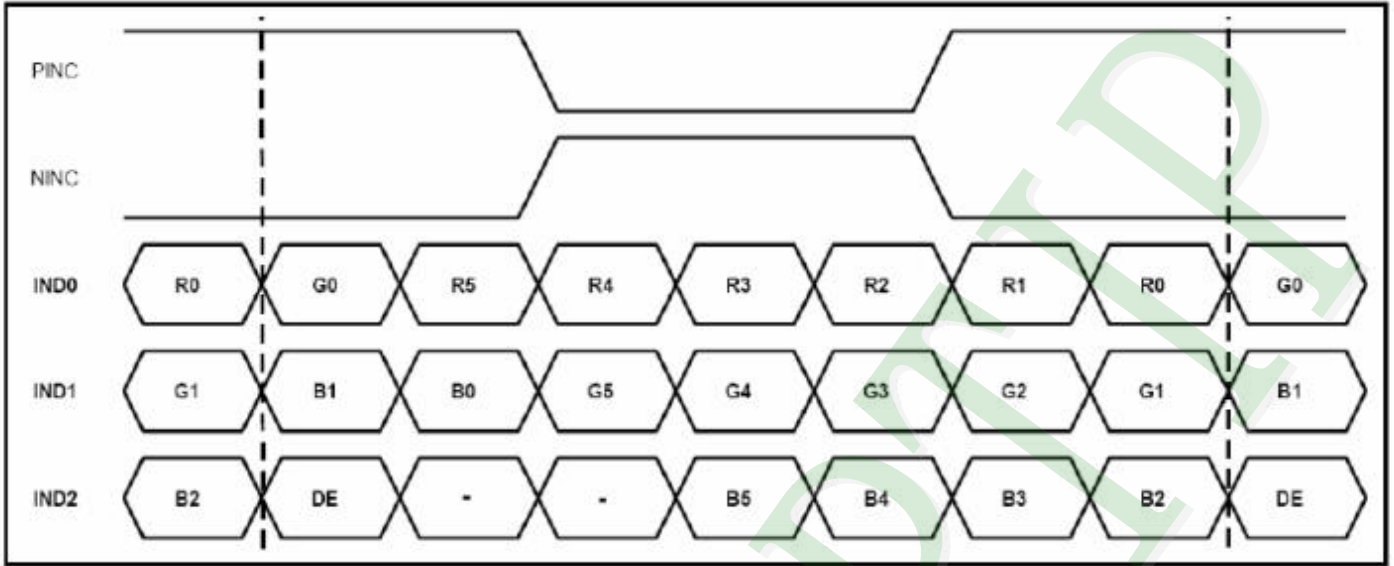

8bit LVDS input

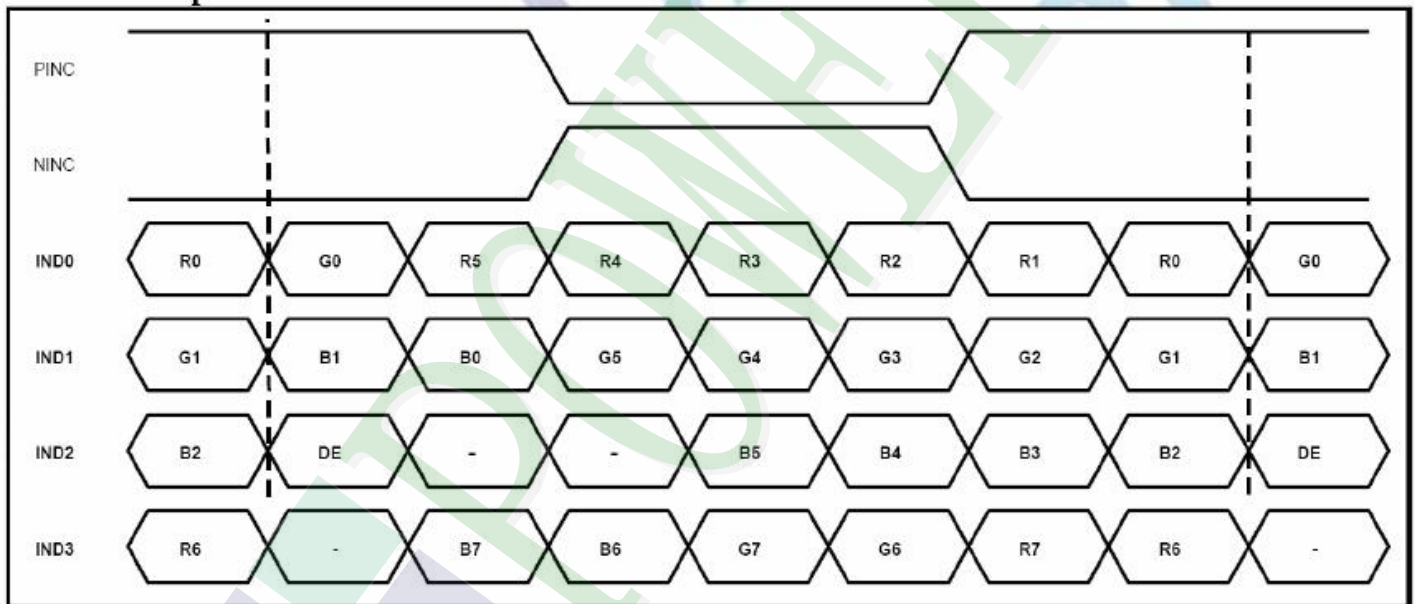

Note: Support DE timing mode only, SYNC mode not supported.

2.3.5 Parallel RGB Input Timing Table

DE mode

Parameter	Symbol	Spec.			Unit
		Min.	Typ.	Max.	
DCLK Frequency	fclk	40.8	51.2	67.2	MHz
Horizontal Display Area	thd		1024		DCLK
HSD Period	th	1114	1344	1400	DCLK
HSD Pulse Width	thpw	1	-	140	DCLK
HSD Blanking	thbp+ thfp	90	320	376	DCLK
Vertical Display Area	tvd		600		T _H
VSD Period	tv	610	635	800	T _H
VSD Pulse Width	tvpw	1	-	20	T _H
VSD Blanking	tvbp+ tvfp	10	35	200	T _H

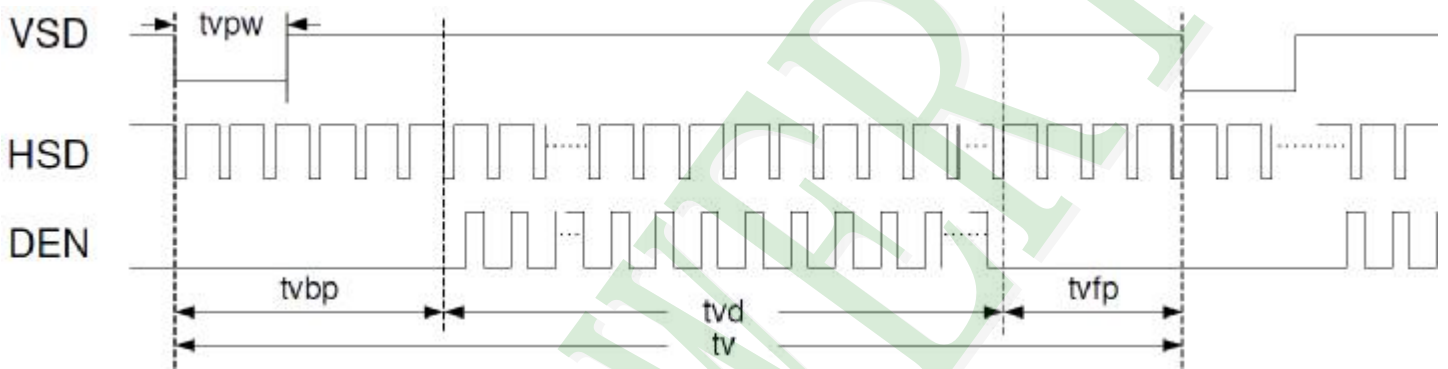

Vertical input timing diagram



Horizontal input timing diagram

3. QUALITY ASSURANCE SYSTEM

3.1 Quality Assurance Flow Chart

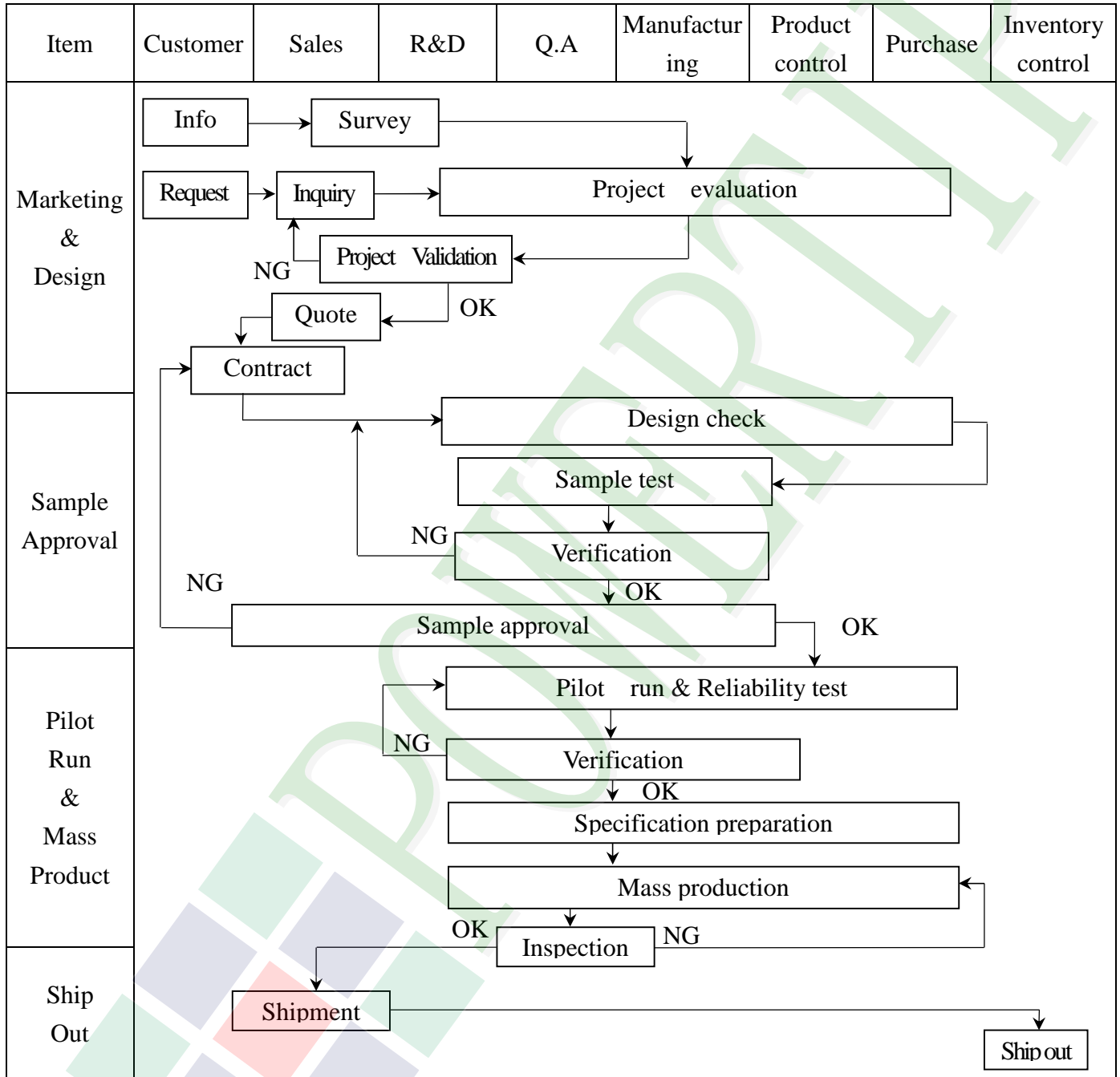

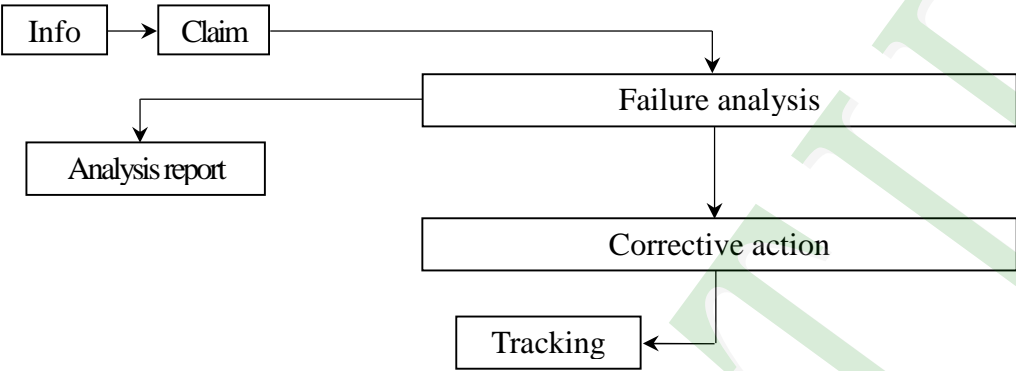
Item	Customer	Sales	R&D	Q.A	Manufacturing	Product control	Purchase	Inventory control
Sales Service	 <pre> graph TD Info[Info] --> Claim[Claim] Claim --> Failure[Failure analysis] Failure --> Report[Analysis report] Failure --> Action[Corrective action] Action --> Tracking[Tracking] </pre>							
Q.A Activity	1. ISO 9001 Maintenance Activities 3. Equipment calibration 5. Standardization Management				2. Process improvement proposal 4. Education And Training Activities			

3.2 Inspection Specification

3.2.1. QUALITY :

THE QUALITY OF GOODS SUPPLIED TO PURCHASER SHALL COME UP TO THE FOLLOWING STANDARD.

1. THE METHOD OF PRESERVING GOODS

AFTER DELIVERY OF GOODS FROM AMSON TO PURCHASER. PURCHASER SHALL CONTROL THE LCM AT -10°C TO 40°C ,AND IT MIGHT BE DESIRABLE TO KEEP AT THE NORMAL ROOM TEMPERATURE AND HUMIDITY UNTIL INCOMING INSPECTION OR THROWING INTO PROCESS LINE.

2. INCOMING INSPECTION

(A) THE METHOD OF INSPECTION

IF PURCHASER MAKE AN INCOMING INSPECTION , A SAMPLING PLAN SHALL BE APPLIED ON THE CONDITION THAT QUALITY OF ONE DELIVERY SHALL BE REGARDED AS ONE LOT.

(B) THE STANDARD OF QUALITY

ISO-2859-1 (SAME AS MIL-STD-105E) , LEVEL II SINGLE PLAN.

CLASS	AQL(%)
CRITICAL	0.4 %
MAJOR	0.65 %
MINOR	1.5 %
TOTAL	1.5 %

EVERY ITEM SHALL BE INSPECTED ACCORDING TO THE CLASS.

(C) MEASURE

IF AS THE RESULT OF ABOVE RECEIVING INSPECTION , A LOT OUT IS DISCOVERED. PURCHASER SHALL BE INFORM SELLER OF IT WITHIN SEVEN DAYS. BUT FIRST SHIPMENT WITHIN FOURTEEN DAYS.

3. WARRANTY POLICY

AMSON WILL PROVIDE ONE-YEAR WARRANTY FOR THE PRODUCTS ONLY IF UNDER SPECIFICATION OPERATING CONDITIONS. AMSON WILL REPLACE NEW PRODUCTS FOR THESE DEFECT PRODUCTS WHICH UNDER WARRANTY PERIOD AND BELONG TO THE RESPONSIBILITY OF AMSON.

3.2.2. CHECKING CONDITION

1.CHECKING DIRECTION SHALL BE IN THE 45 DEGREE AREA TO FACE THE SAMPLE.

2.CHECKER SHALL SEE OVER 300 ± 25 mm. WITH BARE EYES FAR FROM SAMPLE AND USING 2 PCS. OF 20W FLUORESCENT LAMP.

3.2.3. INSPECTION PLAN :

CLASS	ITEM	JUDGEMENT	CLASS
PACKING & INDICATE	1. OUTSIDE AND INSIDE PACKAGE	"MODEL NO." , "LOT NO." AND "QUANTITY" SHOULD INDICATE ON THE PACKAGE.	Minor
	2. MODEL MIXED AND QUANTITY	OTHER MODEL MIXED.....REJECTED QUANTITY SHORT OR OVER.....REJECTED	Critical
	3. PRODUCT INDICATION	"MODEL NO." SHOULD INDICATE ON THE PRODUCT	Major
ASSEMBLY	4. DIMENSION, LCD GLASS SCRATCH AND SCRIBE DEFECT.	ACCORDING TO SPECIFICATION OR DRAWING.	Major
APPEARANCE	5. VIEWING AREA	POLARIZER EDGE OR LCD'S SEALING LINE IS VISABLE IN THE VIEWING AREAREJECTED	Minor
	6. BLEMISH · BLACK SPOT · WHITE SPOT IN THE LCD AND LCD GLASS CRACKS	ACCORDING TO STANDARD OF VISUAL INSPECTION(INSIDE VIEWING AREA)	Minor
	7. BLEMISH · BLACK SPOT WHITE SPOT AND SCRATCH ON THE POLARIZER	ACCORDING TO STANDARD OF VISUAL INSPECTION(INSIDE VIEWING AREA)	Minor
	8. BUBBLE IN POLARIZER	ACCORDING TO STANDARD OF VISUAL INSPECTION(INSIDE VIEWING AREA)	Minor
	9. LCD'S RAINBOW COLOR	STRONG DEVIATION COLOR (OR NEWTON RING) OF LCD.....REJECTED. OR ACCORDING TO LIMITED SAMPLE (IF NEEDED, AND INSIDE VIEWING AREA)	Minor
ELECTRICAL	10. ELECTRICAL AND OPTICAL CHARACTERISTICS (CONTRAST · VOP · CHROMATICITY ... ETC)	ACCORDING TO SPECIFICATION OR DRAWING . (INSIDE VIEWING AREA)	Critical
	11.MISSING LINE	MISSING DOT · LINE · CHARACTERREJECTED	Critical
	12.SHORT CIRCUIT · WRONG PATTERN DISPLAY	NO DISPLAY · WRONG PATTERN DISPLAY · CURRENT CONSUMPTION OUT OF SPECIFICATION..... REJECTED	Critical
	13. DOT DEFECT (FOR COLOR AND TFT)	ACCORDING TO STANDARD OF VISUAL INSPECTION	Minor

3.2.4. STANDARD OF VISUAL INSPECTION

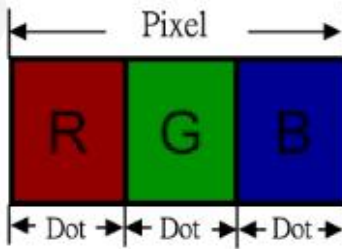
CLASS	ITEM	JUDGEMENT																				
MINOR	BLACK AND WHITE SPOT FOREIGN MATERIEL DUST IN THE CELL BLEMISH SCRATCH	<p>(A) ROUND TYPE: unit : mm.</p> <table border="1"> <thead> <tr> <th>DIAMETER (mm.)</th> <th>ACCEPTABLE Q'TY</th> </tr> </thead> <tbody> <tr> <td>$\Phi \leq 0.1$</td> <td>DISREGARD</td> </tr> <tr> <td>$0.1 < \Phi \leq 0.25$</td> <td>3 (Distance>5mm)</td> </tr> <tr> <td>$0.25 < \Phi$</td> <td>0</td> </tr> </tbody> </table> <p>NOTE: $\Phi = (\text{LENGTH} + \text{WIDTH}) / 2$</p> <p>(B) LINEAR TYPE: unit : mm.</p> <table border="1"> <thead> <tr> <th>LENGTH</th> <th>WIDTH</th> <th>ACCEPTABLE Q'TY</th> </tr> </thead> <tbody> <tr> <td>-----</td> <td>$W \leq 0.03$</td> <td>DISREGARD</td> </tr> <tr> <td>$L \leq 5.0$</td> <td>$0.03 < W \leq 0.07$</td> <td>3 (Distance>5mm)</td> </tr> <tr> <td>-----</td> <td>$0.07 < W$</td> <td>FOLLOW ROUND TYPE</td> </tr> </tbody> </table>	DIAMETER (mm.)	ACCEPTABLE Q'TY	$\Phi \leq 0.1$	DISREGARD	$0.1 < \Phi \leq 0.25$	3 (Distance>5mm)	$0.25 < \Phi$	0	LENGTH	WIDTH	ACCEPTABLE Q'TY	-----	$W \leq 0.03$	DISREGARD	$L \leq 5.0$	$0.03 < W \leq 0.07$	3 (Distance>5mm)	-----	$0.07 < W$	FOLLOW ROUND TYPE
DIAMETER (mm.)	ACCEPTABLE Q'TY																					
$\Phi \leq 0.1$	DISREGARD																					
$0.1 < \Phi \leq 0.25$	3 (Distance>5mm)																					
$0.25 < \Phi$	0																					
LENGTH	WIDTH	ACCEPTABLE Q'TY																				
-----	$W \leq 0.03$	DISREGARD																				
$L \leq 5.0$	$0.03 < W \leq 0.07$	3 (Distance>5mm)																				
-----	$0.07 < W$	FOLLOW ROUND TYPE																				
MINOR	BUBBLE IN POLARIZER DENT ON POLARIZER	<p style="text-align: right;">unit : mm.</p> <table border="1"> <thead> <tr> <th>DIAMETER</th> <th>ACCEPTABLE Q'TY</th> </tr> </thead> <tbody> <tr> <td>$\Phi \leq 0.2$</td> <td>DISREGARD</td> </tr> <tr> <td>$0.2 < \Phi \leq 0.5$</td> <td>2 (Distance>5mm)</td> </tr> <tr> <td>$0.5 < \Phi$</td> <td>0</td> </tr> </tbody> </table>	DIAMETER	ACCEPTABLE Q'TY	$\Phi \leq 0.2$	DISREGARD	$0.2 < \Phi \leq 0.5$	2 (Distance>5mm)	$0.5 < \Phi$	0												
DIAMETER	ACCEPTABLE Q'TY																					
$\Phi \leq 0.2$	DISREGARD																					
$0.2 < \Phi \leq 0.5$	2 (Distance>5mm)																					
$0.5 < \Phi$	0																					
MINOR	Dot Defect	<table border="1"> <thead> <tr> <th>Items</th> <th>ACC. Q'TY</th> </tr> </thead> <tbody> <tr> <td>Bright dot</td> <td>$N \leq 4$</td> </tr> <tr> <td>Dark dot</td> <td>$N \leq 4$</td> </tr> </tbody> </table> <p>Pixel Define :</p>  <p>Note 1: The definition of dot: The size of a defective dot over 1/2 of whole dot is regarded as one defective dot.</p> <p>Note 2: Bright dot: Dots appear bright and unchanged in size in which LCD panel is displaying under black pattern.</p> <p>Note 3: Dark dot: Dots appear dark and unchanged in size in which LCD panel is displaying under pure red, green, blue pattern.</p>	Items	ACC. Q'TY	Bright dot	$N \leq 4$	Dark dot	$N \leq 4$														
Items	ACC. Q'TY																					
Bright dot	$N \leq 4$																					
Dark dot	$N \leq 4$																					

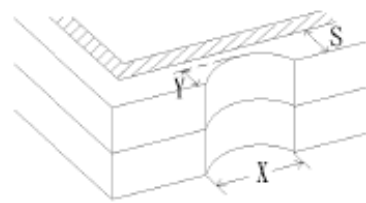
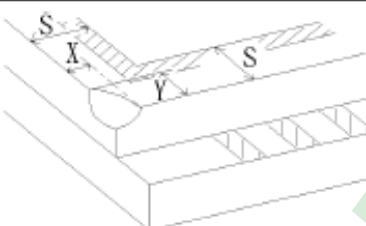
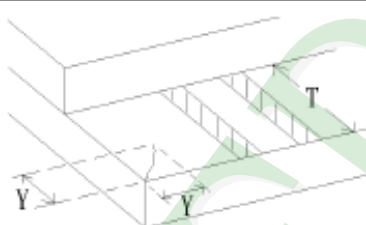
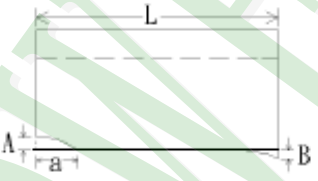
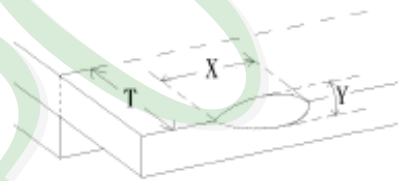
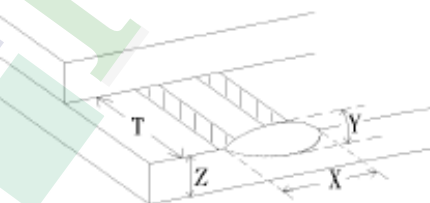
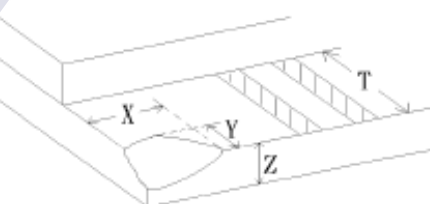
CLASS	ITEM	JUDGEMENT	
MINOR	LCD GLASS CHIPPING	 $Y > S$	Reject
MINOR	LCD GLASS CHIPPING	 $X \text{ or } Y > S$	Reject
MAJOR	LCD GLASS GLASS CRACK	 $Y > (1/2) T$	Reject
MAJOR	LCD GLASS SCRIBE DEFECT	 <ol style="list-style-type: none"> $a > L/3$, $A > 1.5\text{mm}$. B : ACCORDING TO DIMENSION 	Reject
MINOR	LCD GLASS CHIPPING (ON THE TERMINAL AREA)	 $\Phi = (x+y)/2 > 2.5 \text{ mm}$	Reject
MINOR	LCD GLASS CHIPPING (ON THE TERMINAL SURFACE)	 $Y > (1/3) T$	Reject
MINOR	LCD GLASS CHIPPING	 $Y > T$	Reject

4. RELIABILITY TEST

4.1 Reliability Test Condition

(Ver.A01)

Test Item	Test Condition	Remark
High Temperature Storage	Ta=80°C; 240hrs	IEC60068-2-1 : 2007 GB2423.2-2008
Low Temperature Storage	Ta=-30°C; 240hrs	IEC60068-2-1 : 2007 GB2423.1-2008
High Temperature Operation	Ta=70°C , 240Hrs	IEC60068-2-1 : 2007 GB2423.2-2008
Low Temperature Operation	Ta=-20°C; 240hrs	IEC60068-2-1 : 2007 GB2423.1-2008
High Temperature High Humidity Operation	Ta=60°C , 90%RH , 240Hrs(no condensation)	IEC60068-2-78 : 2001 GB/T2423.3-2006
Thermal Shock	-30°C (0.5h) ~ 80°C (0.5h) / 100cycles	Start with cold temperature , End with high temperature , IEC60068-2-14:1984,GB2423.22-2002
Image Sticking	25°C ; 4hrs	Note1

Note1:Condition of image sticking test :25°C±2°C

Operation with test pattern sustained for 4hrs,then change to gray pattern immediately.after5 mins,themura must be disappeared completely

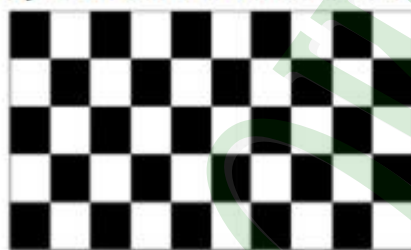

(a) Test Pattern (chess board Pattern)



(b) Gray Pattern

5. PRECAUTION RELATING PRODUCT HANDLING

5.1 SAFETY

- 5.1.1 If the LCD panel breaks , be careful not to get the liquid crystal to touch your skin.
- 5.1.2 If the liquid crystal touches your skin or clothes , please wash it off immediately by using soap and water.

5.2 HANDLING

- 5.2.1 Avoid any strong mechanical shock which can break the glass.
- 5.2.2 Avoid static electricity which can damage the CMOS LSI—When working with the module , be sure to ground your body and any electrical equipment you may be using.
- 5.2.3 Do not remove the panel or frame from the module.
- 5.2.4 The polarizing plate of the display is very fragile. So , please handle it very carefully, do not touch , push or rub the exposed polarizing with anything harder than an HB pencil lead (glass , tweezers , etc.)
- 5.2.5 Do not wipe the polarizing plate with a dry cloth , as it may easily scratch the surface of plate.
- 5.2.6 Do not touch the display area with bare hands , this will stain the display area.
- 5.2.7 Do not use ketonics solvent & aromatic solvent. Use with a soft cloth soaked with a cleaning naphtha solvent.
- 5.2.8 To control temperature and time of soldering is $320 \pm 10^{\circ}\text{C}$ and 3-5 sec.
- 5.2.9 To avoid liquid (include organic solvent) stained on LCM

5.3 STORAGE

- 5.3.1 Store the panel or module in a dark place where the temperature is $25^{\circ}\text{C} \pm 5^{\circ}\text{C}$ and the humidity is below 65% RH.
- 5.3.2 Do not place the module near organics solvents or corrosive gases.
- 5.3.3 Do not crush , shake , or jolt the module.

5.4 TERMS OF WARRANTY

- 5.4.1 Applicable warrant period
The period is within thirteen months since the date of shipping out under normal using and storage conditions.
- 5.4.2 Unaccepted responsibility
This product has been manufactured to your company's specification as a part for use in your company's general electronic products. It is guaranteed to perform according to delivery specifications. For any other use apart from general electronic equipment, we cannot take responsibility if the product is used in nuclear power control equipment, aerospace equipment , fire and security systems or any other applications in which there is a direct risk to human life and where extremely high levels of reliability are required.

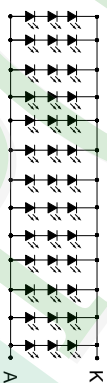
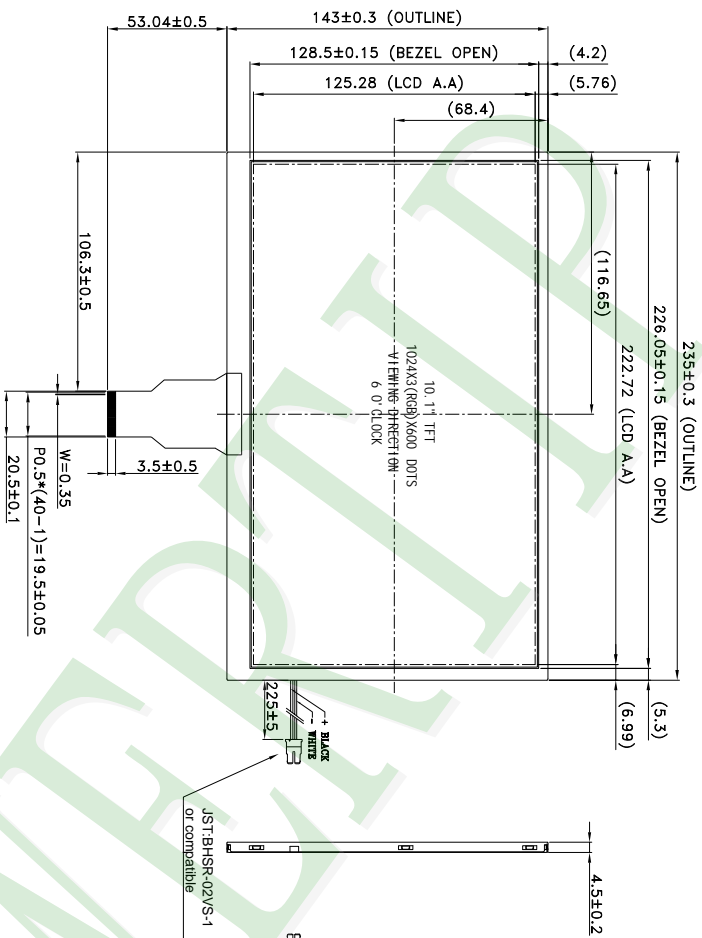

Pin	Assignment
1	VCOM
2	VDD
3	VDD
4	NC
5	RESET
6	STRB
7	GND
8	RX10D-
9	RX10D+
10	GND
11	RX10H+
12	RX10H-
13	GND
14	RX10Z-
15	RX10Z+
16	GND
17	RX10K-
18	RX10K+
19	GND
20	RX10L-
21	RX10L+
22	GND
23	NC
24	NC
25	GND
26	NC
27	DI100
28	SELB
29	AVDD
30	GND
31	LEP-
32	LEP+
33	L/R
34	U/D
35	VGS
36	GND
37	GND
38	VGH
39	LEP-
40	LEP+

- TFT NOTE:
1. LCD TYPE: 16. 7M COLOR , TFT
 2. VIEWING DIRECTION: 6 0' CLOCK
 3. BACKLIGHT: WHITE LED 39 connection
 4. OPERATION TEMP: -20° ~70°
 5. STORAGE TEMP: -30° ~80°
 6. UNMARKERTOLERANCE: ±0.30
 7. FPC suggested connector : (HRS)FH12-40S-0.5SH or compatible

007		PART NO:	PH102600T007-1AA01	<p>久正光电股份有限公司 POWER TIP TECHNOLOGY CORPORATION</p>	Design	Terry	<p>Surface</p>	Material	Precision Level
006		DRAWING NAME :	JLMD-PH102600T007-1AA01		Check	Eddy			
005					Approve	Ryan	Scale	FIT	Thickness
004							Page	1/1	Quantity
003									
002	UPDATE DRAWING								
001	NEW DRAWING								
REV		REV BY	REVISER	DATE					

Approve	Check	Contact
Ryan	Eddy	Terry

Ver.001

LCM包裝規格書

Documents NO. JPKG-PH102600T007-IAA01

LCM Packaging Specifications

1. 包裝材料規格表 (Packaging Material) : (per carton)

No.	Item	Model	Dimensions (mm)	1Pcs Weight	Quantity	Total Weight
1	成品 (LCM)	PH102600T007-IAA01	235X143X4.5	0.2628	20	5.256
2	靜電袋(1)Antistatic Bag	BAG0000000021	240 X 300	0.008	20	0.16
3	上蓋(2)EPE(Cover)	FOAM000000132	520 X 315 X 65	0.108	1	0.108
4	下座(3)EPE(Bottom)	FOAM000000133	520 X 315 X 330	0.85	1	0.85
5	外紙箱(4)Carton	BX52732536CCBA	527 X 325 X 360	1.092	1	1.092
6						

2. 一整箱總重量 (Total LCD Weight in carton) : 7.45 Kg±10%

3. 單箱數量規格表 (Packaging Specifications and Quantity) :

Total LCM quantity in carton : quantity per EPE 20 x no of EPE 1 = 20

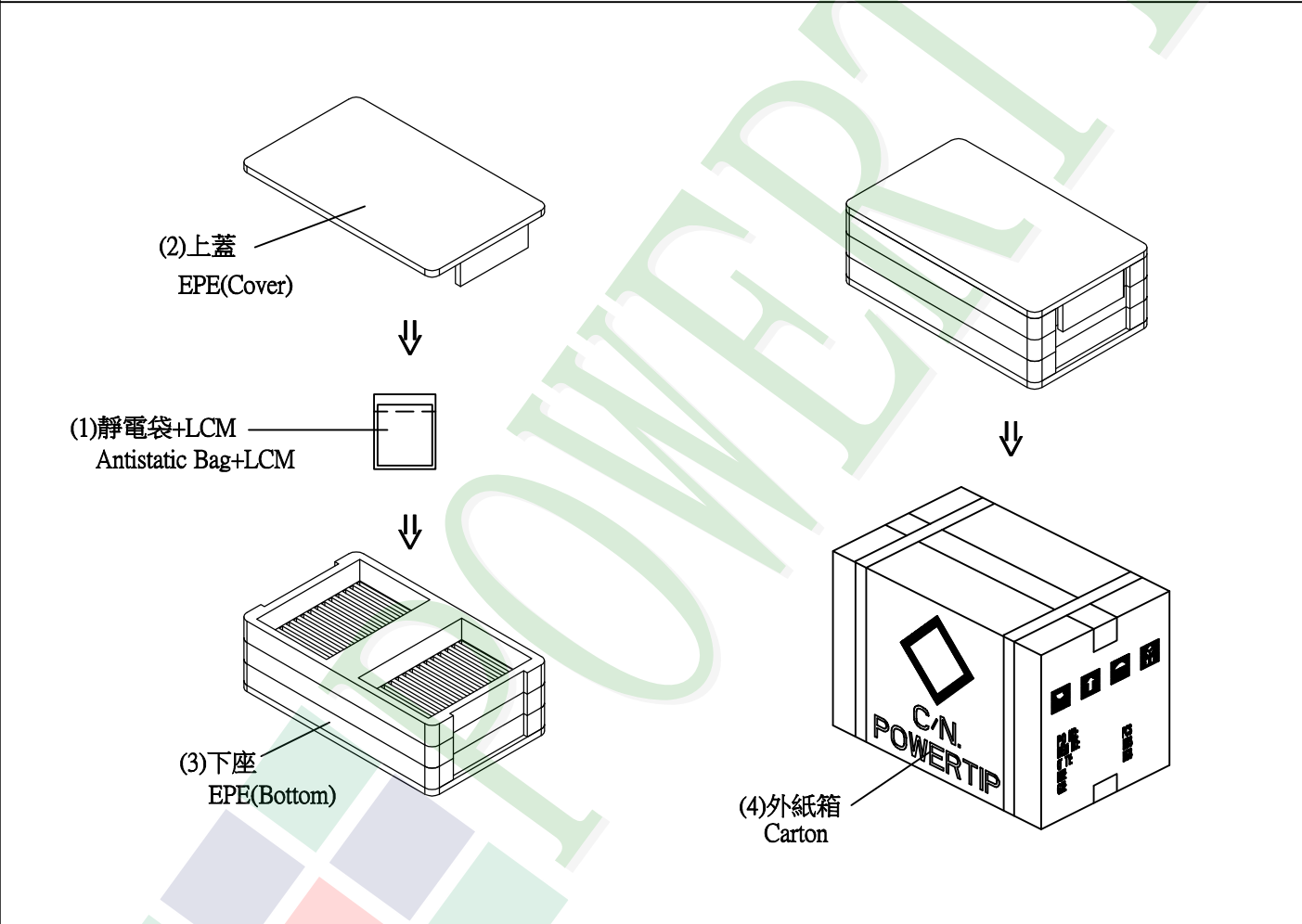

特 記 事 項 (REMARK)

--	--	--

由 AUTODESK 教育產品製造

由 AUTODESK 教育產品製造