

SPECIFICATIONS

CUSTOMER : PTC



SAMPLE CODE (Ver.) : PS320240T-005-I-01 (Ver.A)

MASS PRODUCTION CODE (Ver.) : PH320240T-005-I-Q (Ver.0)

DRAWING NO. (Ver.) : PH-06018-002 (Ver.0)

Customer Approved

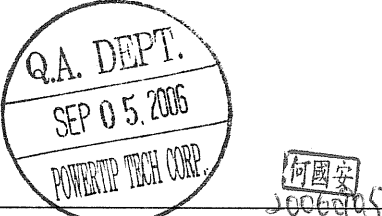
Date:

Approved	QC Confirmed	Designer
		

Approval For Specifications Only.

* This specification is subject to change without notice.

Please contact Powertip or it's representative before designing your product based on this specification.

Approval For Specifications and Sample.

POWERTIP TECH. CORP.

Headquarters:

No.8, 6th Road, Taichung Industrial Park,
 Taichung, Taiwan
 台中市 407 工業區六路 8 號

TEL: 886-4-2355-8168

FAX: 886-4-2355-8166

E-mail: sales@powertip.com.tw

Http://www.powertip.com.tw

Contents

1. SPECIFICATIONS

- 1.1 Features
- 1.2 Mechanical Specifications
- 1.3 Absolute Maximum Ratings
- 1.4 DC Electrical Characteristics
- 1.5 Optical Characteristics
- 1.6 Backlight Characteristics

2. MODULE STRUCTURE

- 2.1 Counter Drawing
- 2.2 Interface Pin Description
- 2.3 Timing Characteristics
- 2.4 JUMPER(Setting different use)

3. QUALITY ASSURANCE SYSTEM

- 3.1 Quality Assurance Flow Chart
- 3.2 Inspection Specification

4. RELIABILITY TEST

- 4.1 Reliability Test Condition

5. PRECAUTION RELATING PRODUCT HANDLING

- 5.1 Safety
- 5.2 Handling
- 5.3 Storage
- 5.4 Terms of Warranty

6. Packaging

Appendix A: LCM Drawing

Appendix B: Package

Note : For detailed information please refer to IC data sheet :

Primacy(TFT LCD) : HX8218 + HX8615

1. SPECIFICATIONS

1.1 Features

LCM

Item	Standard Value
Display Type	320(R · G · B) * 240 Dots
LCD Type	Normally white , Transmissive type
Screen size(inch)	5.7 inch
Viewing Direction	6 O'clock
Color configuration	RGB-Strip
Backlight Type	LED
Interface	Digital 24-bits RGB
Driver IC	HX8218 + HX8615
Item	Standard Value
ROHS	THIS PRODUCT CONFORMS THE ROHS OF PTC Detail information please refer web side : http://www.powertip.com.tw/news/LatestNews.asp

LCM Weight : 40 g

1.2 Mechanical Specifications

Item	Standard Value	Unit
Outline Dimension	167.0(W) * 111.0 (L) * 7.8 (H)(Max)	mm

LCM

Item	Standard Value	Unit
Active Area	115.2 (W) * 86.4 (L)	mm
Pixel Size	0.12 (W) * 0.36 (L)	mm

Note : For detailed information please refer to LCM drawing

1.3 Absolute Maximum Ratings

Module

Item	Symbol	Condition	Min.	Max.	Unit
System Power Supply Voltage	VDD	AVSS=0	-0.3	7.0	V
	VCC	GND=0	-0.3	7.0	
	VGH	GND=0	-0.3	32.0	
	VGL	GND=0	-22.0	0.3	
	VGH-VGL	GND=0	-0.3	45.0	
Input Voltage	V _i	-	-0.3	VDD+0.3	V
	V _I	-	-0.3	VCC+0.3	V
Operating Temperature	T _{OP}	Excluded B/L	-20	70	°C
Storage Temperature	T _{ST}	Excluded B/L	-30	80	°C

1.4 DC Electrical Characteristics

Module		Gnd = 0V , Ta = 25°C				
Item	Symbol	Condition	Min.	Typ.	Max.	Unit
Analog Supply Voltage	VDD	-	3	3.3	3.6	V
Analog Operation Current	IDD	VDD = 3.3V Pattern=full display	-	75	-	mA
		VDD = 3.3V Pattern= black *1		75	125	
Gate On Power	V _{GH}			15		V
Gate Off Power	V _{GL}			-10		V
V _{COM} High Voltage	V _{COMH}		2.5	-	4.0	V
V _{COM} Low Voltage	V _{COML}		-2	-	0	V
Frame frequency	f _{Frame}		-	60	90	Hz
Dot Data Clock	DCLK		-	-	6.4	MHz
Power consumption	P _{LCD}		-	248	450	mW

Note1:Maximum current display

1.5 Optical Characteristics

TFT LCD panel

Ta=25°C

Item		Symbol	Condition	Min.	Typ.	Max.	unit	
Response time	Rise	Tr	Ta = 25°C θX, θY = 0°	-	15	30	ms	Note4
	Fall	Tf		-	35	50		
Viewing angle	Top	θY+	CR ≥ 10	-	15	-	Deg.	Note1&2
	Bottom	θY-		-	35	-		
	Left	θX-		-	45	-		
	Right	θX+		-	45	-		
Contrast ratio		CR	Ta = 25°C θX, θY = 0°	400	500	-		Note3
Color of CIE Coordinate (With B/L)	White	X		0.25	0.31	0.37	-	Note1
		Y		0.29	0.35	0.41		
	Red	X		0.57	0.63	0.69		
		Y		0.3	0.36	0.42		
	Green	X		0.26	0.32	0.38		
		Y		0.52	0.58	0.64		
	Blue	X		0.08	0.14	0.2		
		Y		0.05	0.11	0.17		
Average Brightness Pattern=white display (With LCD)		IV	IF= 60mA	300	380	-	cd/m ²	
Uniformity (With LCD)*1		△B	IF= 60mA	70			%	

*1 : $\Delta B = (B(\min) / B(\max)) * 100$

Note 1: Definition of angles θ and \varnothing

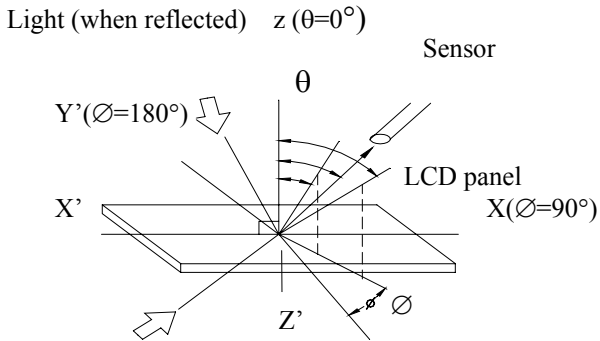

Light (when reflected) $z (\theta=0^\circ)$
 Light (when transmitted) $Y (\varnothing=0^\circ)$
 $(\theta=90^\circ)$

Note 2: Definition of viewing angles θ_1 and θ_2

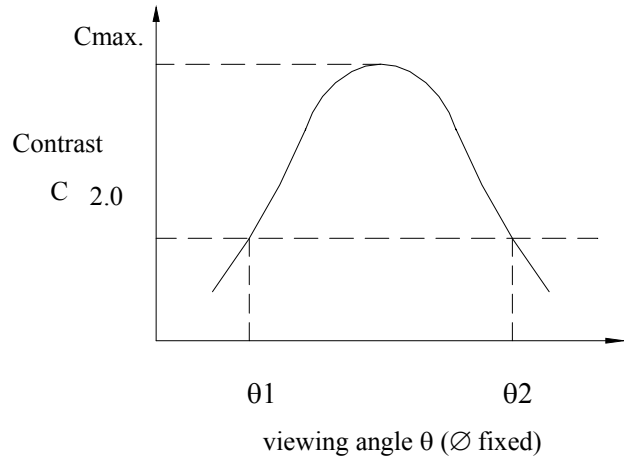

Note : Optimum viewing angle with the naked eye and viewing angle θ at C_{max} . Above are not always the same

Note 3: Definition of contrast C

$$C = \frac{\text{Brightness (reflection) of unselected dot (B2)}}{\text{Brightness (reflection) of selected dot (B1)}}$$

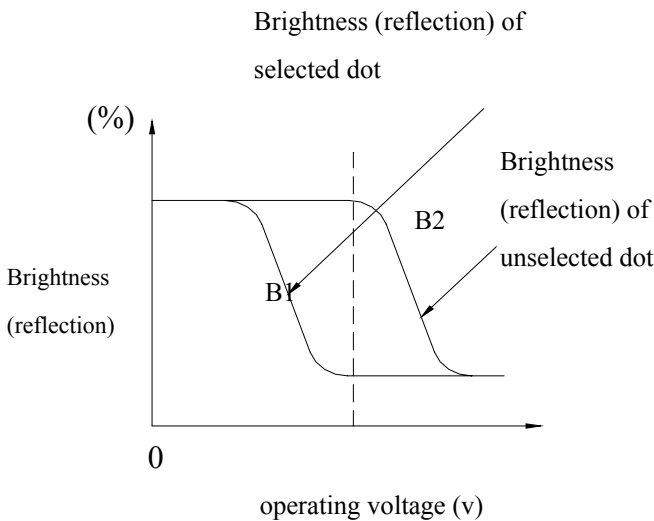

Note 4: Definition of response time

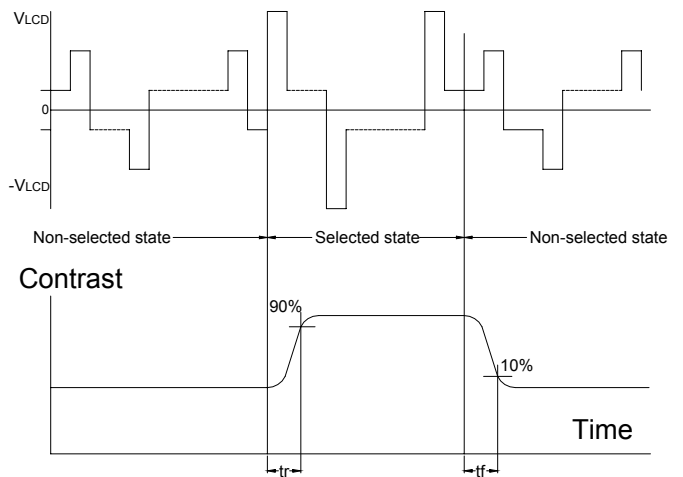

Note: Measured with a transmissive LCD panel which is displayed 1 cm^2

V_{LCD} : Operating voltage f_{FRM} : Frame frequency
 t_r : Response time (rise) t_f : Response time (fall)

1.6 Backlight Characteristics

LCD Module with LED Backlight

Maximum Ratings

Item	Symbol	Conditions	Min.	Max.	Unit
Forward Current	IF	Ta =25°C	-	75	mA
Reverse Voltage	VR	Ta =25°C	-	45	V
Power Dissipation	PO	Ta =25°C	-	2700	mW

Electrical / Optical Characteristics

Item	Symbol	Conditions	Min.	Typ.	Max.	Unit
Forward Voltage	VF	IF= 60 mA	-	33	36	V
Reverse Current	IR	VR= 45 V	-	50	-	uA

2. MODULE STRUCTURE

2.1 Counter Drawing

2.1.1 LCM Mechanical Diagram

* See Appendix

2.1.2 Block Diagram

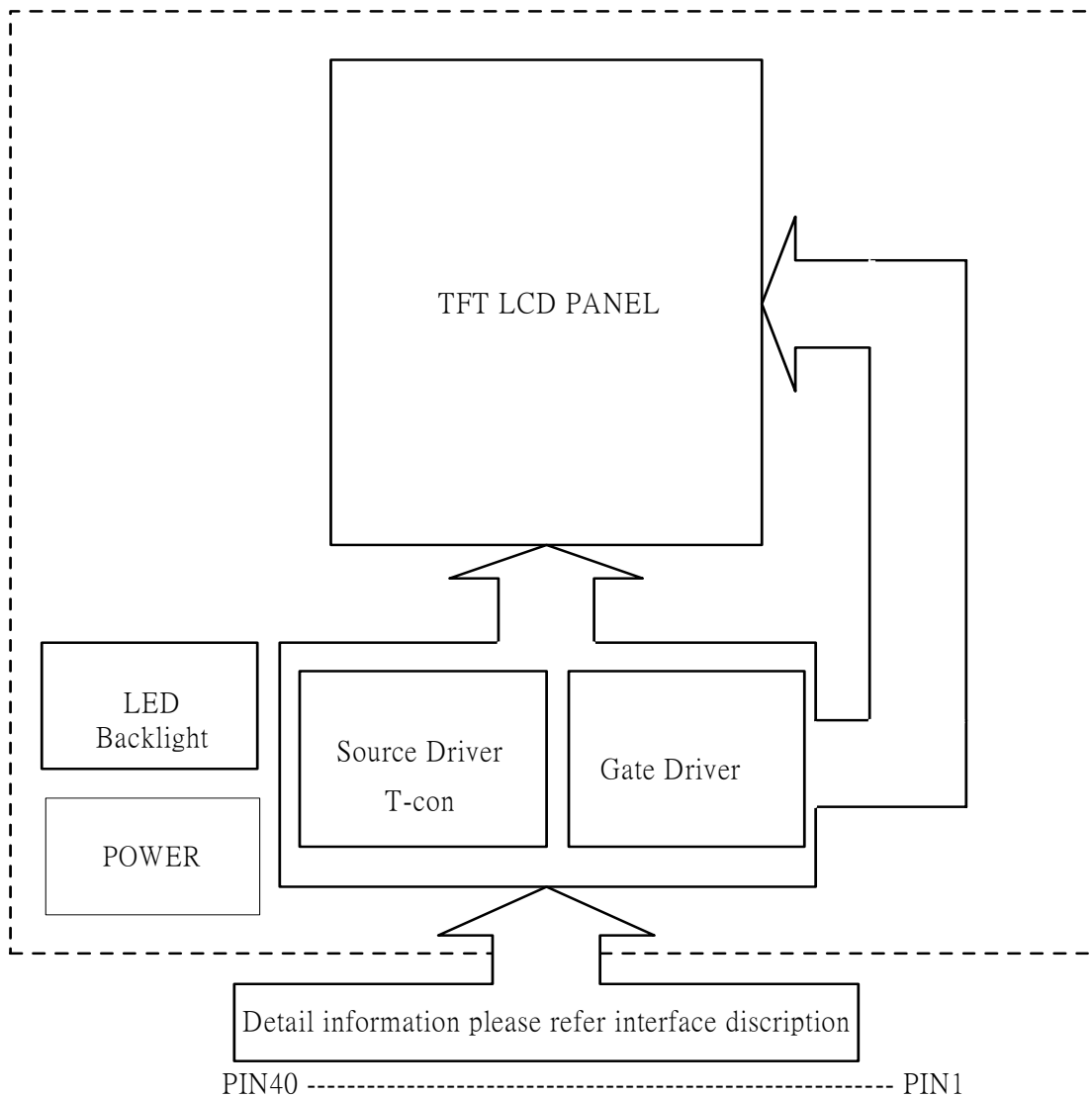

2.2 Interface Pin Description

Pin No.	Symbol	Function
1	VDD	Analog power.
2	VDD	
3	VDD	
4	VDD	
5	VSYNC	Vertical sync input
6	ENB	Data enable control
7	VSS	Ground
8	DCLK	Dot data clock
9	VSS	Ground
10	HSYNC	Horizontal sync input
11	B7	data bit b7
12	B6	data bit b6
13	B5	data bit b5
14	B4	data bit b4
15	B3	data bit b3
16	B2	data bit b2
17	B1	data bit b1
18	B0	data bit b0
19	G7	data bit g7
20	G6	data bit g6
21	G5	data bit g5
22	G4	data bit g4
23	G3	data bit g3
24	G2	data bit g2
25	G1	data bit g1
26	G0	data bit g0

Interface Pin Description(CONT.)

27	R7	data bit r7
28	R6	data bit r6
29	R5	data bit r5
30	R4	data bit r4
31	R3	data bit r3
32	R2	data bit r2
33	R1	data bit r1
34	R0	data bit r0
35	VSS	Ground
36	VSS	Ground
37	NC	No use.
38	NC	No use.
39	NC	No use.
40	NC	No use.

Backlight Pin Description

1	A	Power supply for LED Backlight anode input.
2	NC	No use.
3	K	Power supply for LED Backlight cathode input.

2.3 Timing Characteristics

Signal	Item	Symbol	Min.	Typ.	Max.	Unit	
Dclk	Frequency	Dclk		6.4		MHz	
	High Time	Tch		78		ns	
	Low Time	Tcl		78		ns	
Data	Setup Time	Tds	12			ns	
	Hold Time	Tdh	12			ns	
Hsync	Period	TH		408		DCLK	
	Pulse Width	Thp		30		DCLK	
	Back-Porch	Thb		38		DCLK	
	Display Period	Thd		320		DCLK	
	Front-Porch	Thf		20		DCLK	
Vsync	Period	NTSC	Tv	262.5		TH	
		PAL		312.5			
	Pulse Width		Tvp	1	3	5	TH
	Back-Porch	NTSC	Tvb	15		TH	
		PAL		23			
	Display Period		Tvd		240		TH
	Front-Porch	NTSC	Tvf	4.5		TH	
		PAL		46.5			

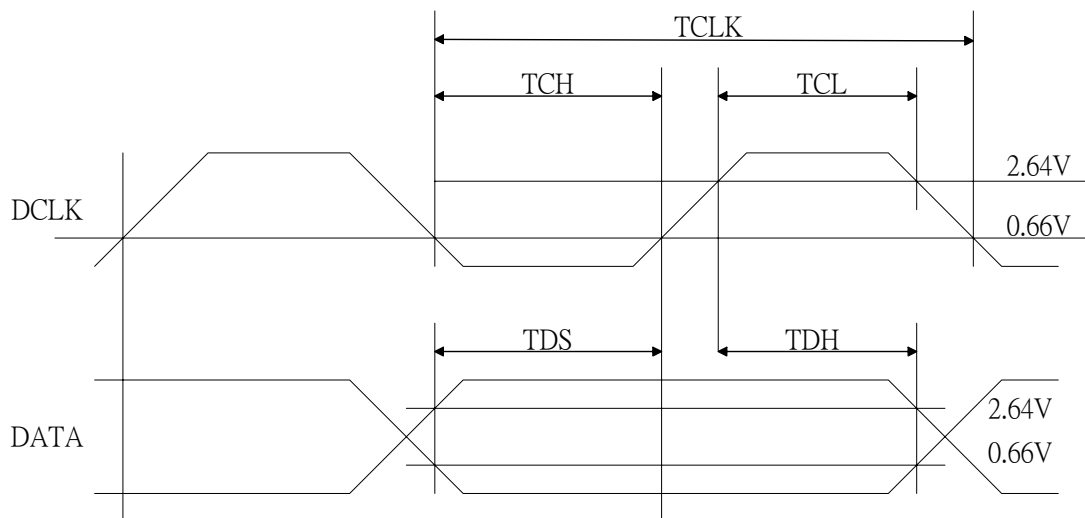

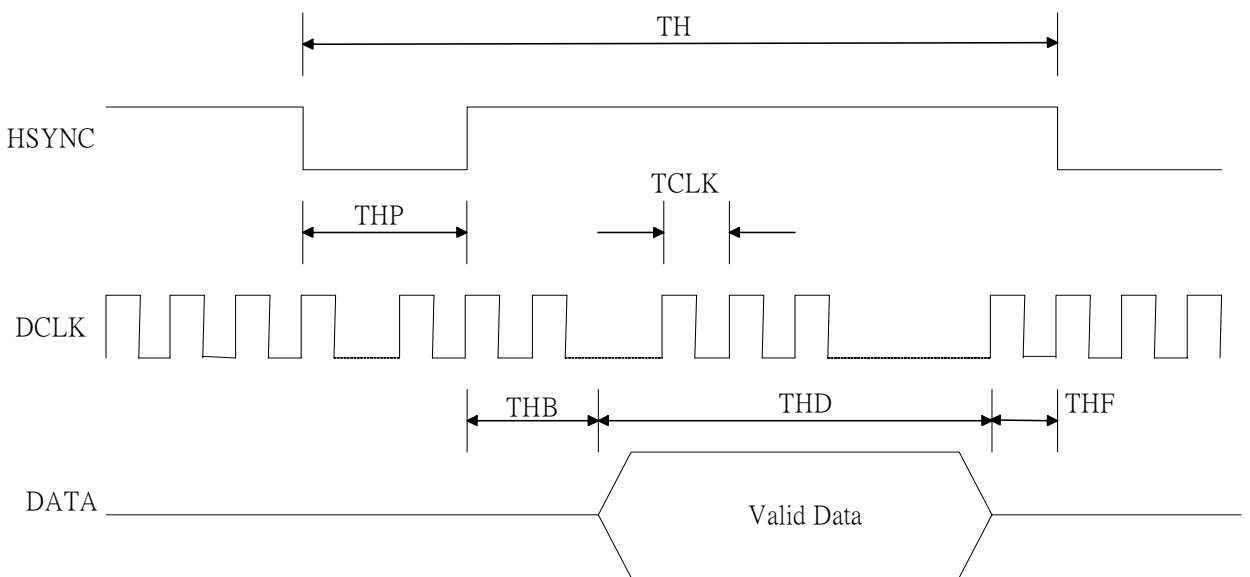
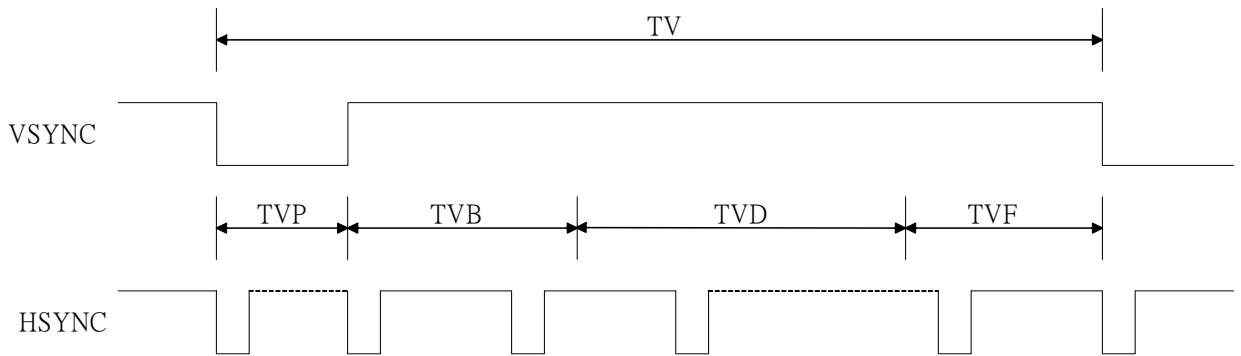
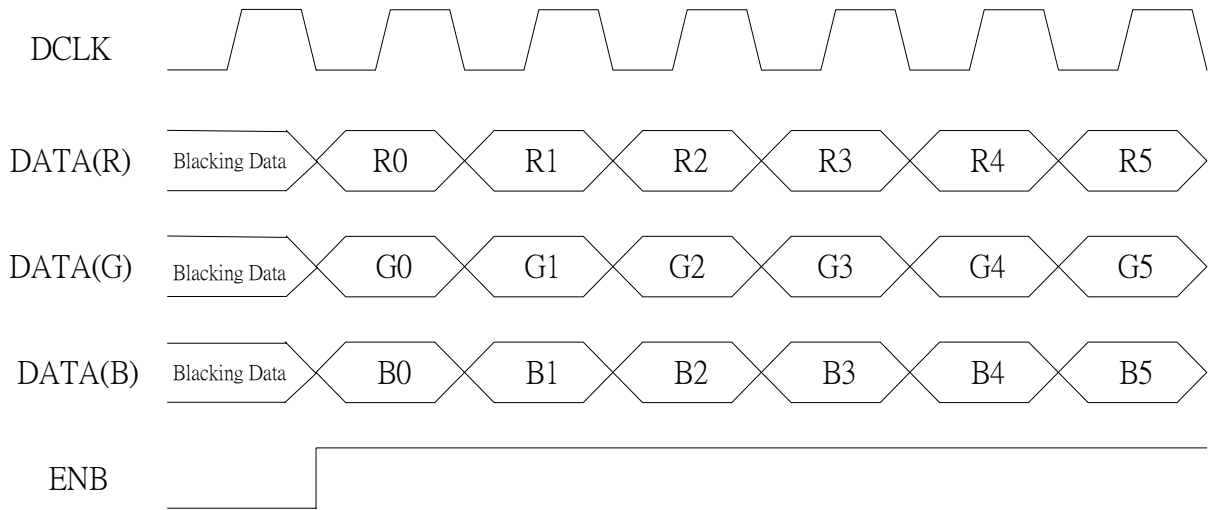

2.4 JUMPER(Setting different use)
(J1-1J2-2,J3-2,J4-1,J5-1,J6-2)

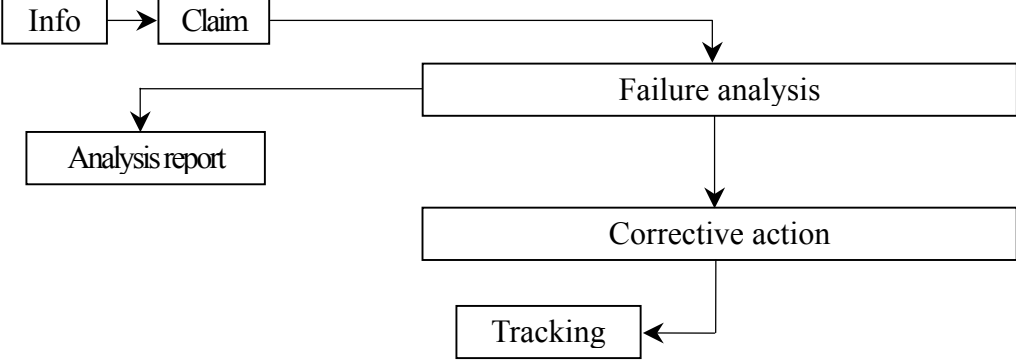
Item	Customer	Sales	R&D	Q.A	Manufacturing	Product control	Purchase	Inventory control
Sales Service	 <pre> graph TD Info[Info] --> Claim[Claim] Claim --> Failure[Failure analysis] Failure --> Analysis[Analysis report] Failure --> Corrective[Corrective action] Corrective --> Tracking[Tracking] </pre>							
Q.A Activity	1. ISO 9001 Maintenance Activities 3. Equipment calibration 5. Standardization Management				2. Process improvement proposal 4. Education And Training Activities			

3.2 Inspection Specification

- ◆Scope : The document shall be applied to TFT-LCD Module for 3.5" ~10" (Ver. 01).
- ◆Inspection Standard : MIL-STD-105E Table Normal Inspection Single Sampling Level II.
- ◆Equipment : Gauge 、MIL-STD 、Powertip Tester 、Sample
- ◆Defect Level : Major Defect AQL : 0.4 ; Minor Defect AQL : 1.5
- ◆OUT Going Defect Level : Sampling.
- ◆Standard of the product appearance test :

a. Manner of appearance test :

- (1). The test best be under 20W×2 fluorescent light , and distance of view must be at 30 cm.
- (2). The test direction is base on about around 45° of vertical line.

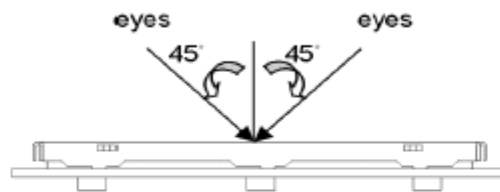

(3). Definition of area.

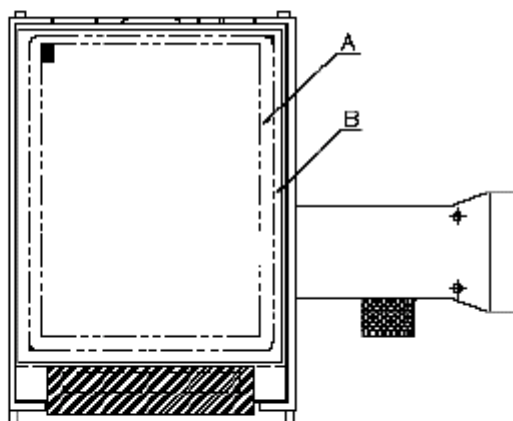

A area : viewing area

B area : Outside of viewing area

(4). Standard of inspection : (Unit : mm)

◆ Specification For TFT-LCD Module 3.5" ~10" :

(Ver. 01)

NO	Item	Criterion	Level												
01	Product condition	1. 1 The part number is inconsistent with work order of production.	Major												
		1. 2 Mixed product types.	Major												
		1. 3 Assembled in inverse direction.	Major												
02	Quantity	2. 1 The quantity is inconsistent with work order of production.	Major												
03	Outline dimension	3. 1 Product dimension and structure must conform to structure diagram.	Major												
04	Electrical Testing	4. 1 Missing line character and icon.	Major												
		4. 2 No function or no display.	Major												
		4. 3 Display malfunction.	Major												
		4. 4 LCD viewing angle defect.	Major												
		4. 5 Current consumption exceeds product specifications.	Major												
05	Dot defect (Bright dot 、 Dark dot) On -display	<table border="1" style="margin-left: auto; margin-right: auto;"> <thead> <tr> <th colspan="2">Item</th> <th>Acceptance (Q'ty)</th> </tr> </thead> <tbody> <tr> <td rowspan="4" style="text-align: center; vertical-align: middle;">Dot Defect</td> <td style="text-align: center;">Bright Dot</td> <td style="text-align: center;">≤ 4</td> </tr> <tr> <td style="text-align: center;">Dark Dot</td> <td style="text-align: center;">≤ 5</td> </tr> <tr> <td style="text-align: center;">Joint Dot</td> <td style="text-align: center;">≤ 3</td> </tr> <tr> <td style="text-align: center;">Total</td> <td style="text-align: center;">≤ 7</td> </tr> </tbody> </table>	Item		Acceptance (Q'ty)	Dot Defect	Bright Dot	≤ 4	Dark Dot	≤ 5	Joint Dot	≤ 3	Total	≤ 7	Minor
		Item		Acceptance (Q'ty)											
Dot Defect	Bright Dot	≤ 4													
	Dark Dot	≤ 5													
	Joint Dot	≤ 3													
	Total	≤ 7													
5. 1 Inspection pattern : full white , full black , Red , Green and blue screens. 5. 2 It is defined as dot defect if defect area $> 1/2$ dot. 5. 3 The distance between two dot defect ≥ 5 mm.															

◆ Specification For TFT-LCD Module 3.5" ~10" :

(Ver. 01)

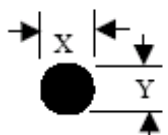
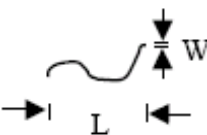
NO	Item	Criterion	Level																												
06	<p>Black or white dot、scratch、contamination</p> <p>Round type</p>  <p>$\Phi = (x + y) / 2$</p> <p>Line type</p> 	<p>6. 1 Round type (Non-display or display) :</p> <table border="1" data-bbox="534 470 1284 840"> <thead> <tr> <th>Dimension (diameter : Φ)</th> <th>Acceptance (Q'ty)</th> </tr> </thead> <tbody> <tr> <td>$\Phi \leq 0.25$</td> <td>Ignore</td> </tr> <tr> <td>$0.25 < \Phi \leq 0.50$</td> <td>5</td> </tr> <tr> <td>$\Phi > 0.50$</td> <td>0</td> </tr> <tr> <td>Total</td> <td>5</td> </tr> </tbody> </table> <p>6. 2 Line type(Non-display or display) :</p> <table border="1" data-bbox="502 996 1316 1433"> <thead> <tr> <th>Length (L)</th> <th>Width (W)</th> <th>Acceptance (Q'ty)</th> </tr> </thead> <tbody> <tr> <td>---</td> <td>$W \leq 0.03$</td> <td>Ignore</td> </tr> <tr> <td>$L \leq 10.0$</td> <td>$0.03 < W \leq 0.05$</td> <td>4</td> </tr> <tr> <td>$L \leq 5.0$</td> <td>$0.05 < W \leq 0.10$</td> <td>2</td> </tr> <tr> <td>---</td> <td>$W > 0.10$</td> <td>As round type</td> </tr> <tr> <td colspan="2">Total</td> <td>5</td> </tr> </tbody> </table>	Dimension (diameter : Φ)	Acceptance (Q'ty)	$\Phi \leq 0.25$	Ignore	$0.25 < \Phi \leq 0.50$	5	$\Phi > 0.50$	0	Total	5	Length (L)	Width (W)	Acceptance (Q'ty)	---	$W \leq 0.03$	Ignore	$L \leq 10.0$	$0.03 < W \leq 0.05$	4	$L \leq 5.0$	$0.05 < W \leq 0.10$	2	---	$W > 0.10$	As round type	Total		5	Minor
Dimension (diameter : Φ)	Acceptance (Q'ty)																														
$\Phi \leq 0.25$	Ignore																														
$0.25 < \Phi \leq 0.50$	5																														
$\Phi > 0.50$	0																														
Total	5																														
Length (L)	Width (W)	Acceptance (Q'ty)																													
---	$W \leq 0.03$	Ignore																													
$L \leq 10.0$	$0.03 < W \leq 0.05$	4																													
$L \leq 5.0$	$0.05 < W \leq 0.10$	2																													
---	$W > 0.10$	As round type																													
Total		5																													
07	Polarizer Bubble	<table border="1" data-bbox="494 1534 1316 1937"> <thead> <tr> <th>Dimension (diameter : Φ)</th> <th>Acceptance (Q'ty)</th> </tr> </thead> <tbody> <tr> <td>$\Phi \leq 0.25$</td> <td>Ignore</td> </tr> <tr> <td>$0.25 < \Phi \leq 0.50$</td> <td>4</td> </tr> <tr> <td>$0.50 < \Phi \leq 0.80$</td> <td>1</td> </tr> <tr> <td>$\Phi > 0.80$</td> <td>0</td> </tr> <tr> <td>Total</td> <td>5</td> </tr> </tbody> </table>	Dimension (diameter : Φ)	Acceptance (Q'ty)	$\Phi \leq 0.25$	Ignore	$0.25 < \Phi \leq 0.50$	4	$0.50 < \Phi \leq 0.80$	1	$\Phi > 0.80$	0	Total	5	Minor																
Dimension (diameter : Φ)	Acceptance (Q'ty)																														
$\Phi \leq 0.25$	Ignore																														
$0.25 < \Phi \leq 0.50$	4																														
$0.50 < \Phi \leq 0.80$	1																														
$\Phi > 0.80$	0																														
Total	5																														

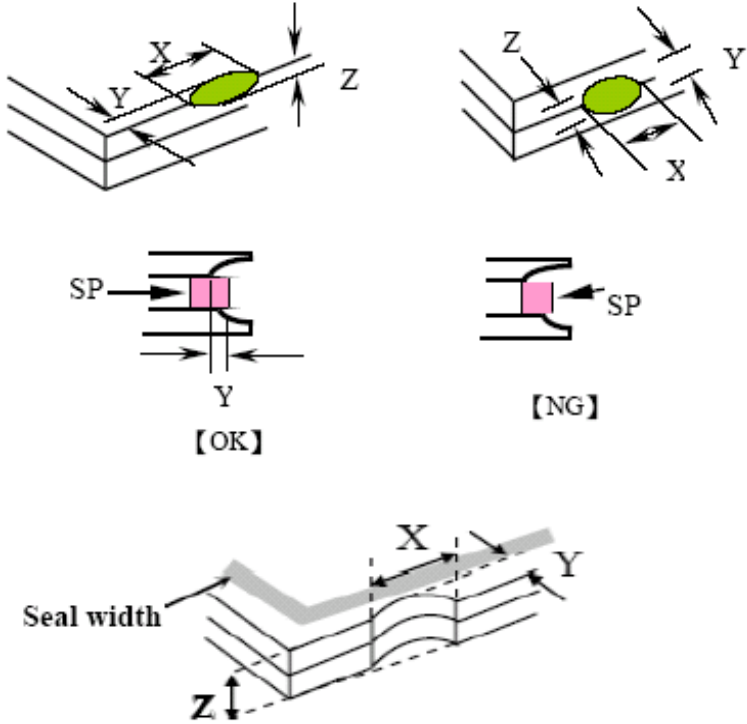
NO	Item	Criterion	Level						
08	The crack of glass	<p>Symbols :</p> <p>X : The length of crack Y : The width of crack. Z : The thickness of crack D : terminal length t : The thickness of glass a : LCD side length</p>	Minor						
		<p>8.1 General glass chip :</p> <p>8.1.1 Chip on panel surface and crack between panels:</p>  <table border="1" data-bbox="539 1621 1337 1912"> <thead> <tr> <th>X</th> <th>Y</th> <th>Z</th> </tr> </thead> <tbody> <tr> <td>$\leq a$</td> <td>Crack can't enter viewing area</td> <td>$\leq 1/2 t$</td> </tr> <tr> <td>$\leq a$</td> <td>Crack can't exceed the half of SP width.</td> <td>$1/2 t < Z \leq 2 t$</td> </tr> </tbody> </table>		X	Y	Z	$\leq a$	Crack can't enter viewing area	$\leq 1/2 t$
X	Y	Z							
$\leq a$	Crack can't enter viewing area	$\leq 1/2 t$							
$\leq a$	Crack can't exceed the half of SP width.	$1/2 t < Z \leq 2 t$							

◆ Specification For TFT-LCD Module 3.5" ~10" :

(Ver. 01)

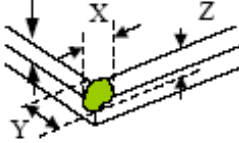
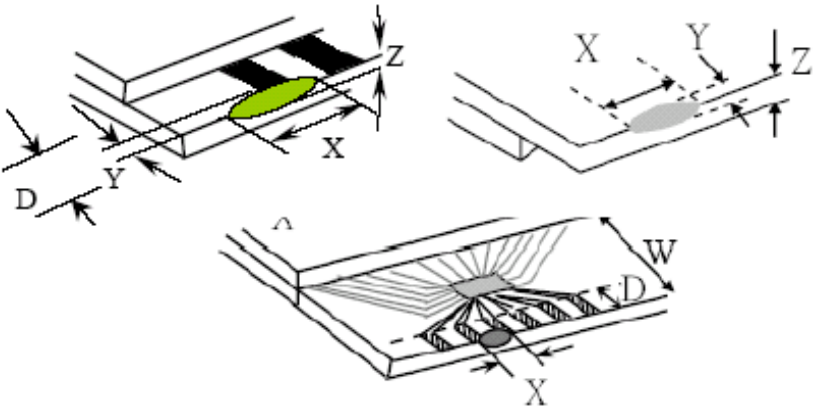
NO	Item	Criterion	Level										
08	The crack of glass	<p>Symbols :</p> <p>X : The length of crack Z : The thickness of crack t : The thickness of glass</p> <p>Y : The width of crack. D : terminal length a : LCD side length</p> <hr/> <p>8.1.2 Corner crack :</p>  <table border="1" data-bbox="517 837 1310 1122"> <thead> <tr> <th>X</th> <th>Y</th> <th>Z</th> </tr> </thead> <tbody> <tr> <td>$\leq 1/5 a$</td> <td>Crack can't enter viewing area</td> <td>$Z \leq 1/2 t$</td> </tr> <tr> <td>$\leq 1/5 a$</td> <td>Crack can't exceed the half of SP width.</td> <td>$1/2 t < Z \leq 2 t$</td> </tr> </tbody> </table>	X	Y	Z	$\leq 1/5 a$	Crack can't enter viewing area	$Z \leq 1/2 t$	$\leq 1/5 a$	Crack can't exceed the half of SP width.	$1/2 t < Z \leq 2 t$	Minor	
		X	Y	Z									
$\leq 1/5 a$	Crack can't enter viewing area	$Z \leq 1/2 t$											
$\leq 1/5 a$	Crack can't exceed the half of SP width.	$1/2 t < Z \leq 2 t$											
<p>8.2 Protrusion over terminal :</p> <p>8.2.1 Chip on electrode pad :</p>  <table border="1" data-bbox="555 1749 1321 1917"> <thead> <tr> <th></th> <th>X</th> <th>Y</th> <th>Z</th> </tr> </thead> <tbody> <tr> <td>Front</td> <td>$\leq a$</td> <td>$\leq 1/2 D$</td> <td>$\leq t$</td> </tr> <tr> <td>Back</td> <td>$\leq a$</td> <td>$\leq D$</td> <td>$\leq 1/2 t$</td> </tr> </tbody> </table>		X	Y	Z	Front	$\leq a$	$\leq 1/2 D$	$\leq t$	Back	$\leq a$	$\leq D$	$\leq 1/2 t$	
	X	Y	Z										
Front	$\leq a$	$\leq 1/2 D$	$\leq t$										
Back	$\leq a$	$\leq D$	$\leq 1/2 t$										

◆ Specification For TFT-LCD Module 3.5" ~10" :

(Ver. 01)

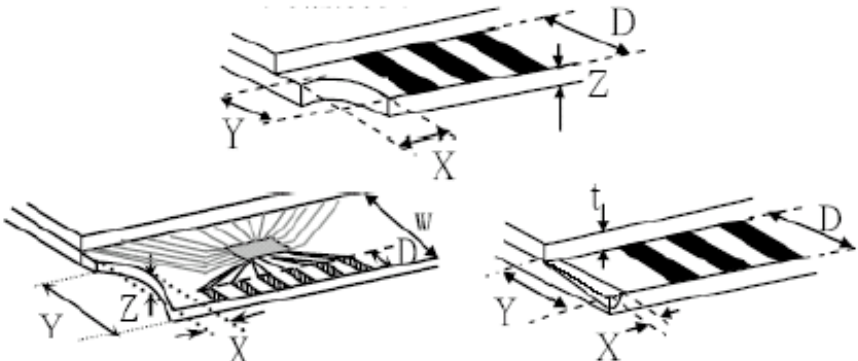
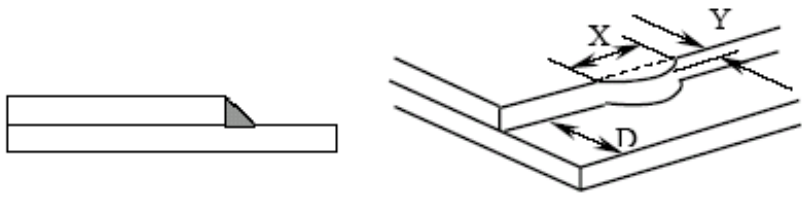
NO	Item	Criterion	Level									
08	The crack of glass	<p>Symbols :</p> <p>X : The length of crack Y : The width of crack. Z : The thickness of crack D : terminal length t : The thickness of glass a : LCD side length</p>	Minor									
		<p>8.2.2 Non-conductive portion :</p>  <table border="1" data-bbox="647 1173 1270 1330"> <thead> <tr> <th>X</th> <th>Y</th> <th>Z</th> </tr> </thead> <tbody> <tr> <td>$\leq 1/3 a$</td> <td>$\leq D$</td> <td>$\leq t$</td> </tr> </tbody> </table> <p>8.2.3 Glass remain :</p>  <table border="1" data-bbox="571 1787 1254 1921"> <thead> <tr> <th>X</th> <th>Y</th> <th>Z</th> </tr> </thead> <tbody> <tr> <td>$\leq a$</td> <td>$\leq 1/3 D$</td> <td>$\leq t$</td> </tr> </tbody> </table>		X	Y	Z	$\leq 1/3 a$	$\leq D$	$\leq t$	X	Y	Z
X	Y	Z										
$\leq 1/3 a$	$\leq D$	$\leq t$										
X	Y	Z										
$\leq a$	$\leq 1/3 D$	$\leq t$										

◆Specification For TFT-LCD Module 3.5" ~10" :

(Ver. 01)

NO	Item	Criterion	Level
09	Backlight elements	9. 1 Backlight can't work normally.	Major
		9. 2 Backlight doesn't light or color is wrong.	Major
		9. 3 Illumination source flickers when lit.	Major
10	General appearance	10. 1 Pin type 、 quantity 、 dimension must match type in structure diagram.	Major
		10. 2 No short circuits in components on PCB or FPC .	Major
		10. 3 Parts on PCB or FPC must be the same as on the production characteristic chart .There should be no wrong parts , missing parts or excess parts.	Major
		10. 4 Product packaging must the same as specified on packaging specification sheet.	Minor
		10. 5 The folding and peeled off in polarizer are not acceptable.	Minor
		10. 6 The PCB or FPC between B/L assembled distance(PCB or FPC) is ≤ 1.5 mm.	Minor

4. RELIABILITY TEST

4.1 Reliability Test Condition

(Ver. 01)

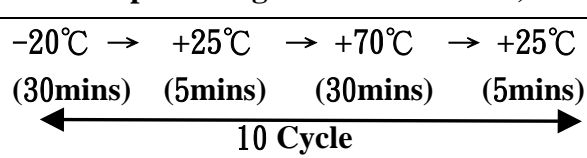
NO	TEST ITEM	TEST CONDITION											
1	High Temperature Storage Test	Keep in +80 ±2°C 96 hrs Surrounding temperature, then storage at normal condition 4hrs.											
2	Low Temperature Storage Test	Keep in -30 ±2°C 96 hrs Surrounding temperature, then storage at normal condition 4hrs.											
3	High Temperature / High Humidity Storage Test	Keep in +60°C / 90% R.H duration for 96 hrs Surrounding temperature, then storage at normal condition 4hrs. (Excluding the polarizer)											
4	ESD Test	Air Discharge: Apply 6 KV with 5 times Discharge for each polarity +/-	Contact Discharge: Apply 250V with 5 times discharge for each polarity +/-										
		1. Temperature ambience:15°C ~35°C 2. Humidity relative:30%~60% 3. Energy Storage Capacitance(Cs+Cd):150pF±10% 4. Discharge Resistance(Rd):330Ω±10% 5. Discharge, mode of operation: Single Discharge (time between successive discharges at least 1 s) (Tolerance if the output voltage indication: ±5%)											
5	Temperature Cycling Storage Test	-20°C → +25°C → +70°C → +25°C (30mins) (5mins) (30mins) (5mins)  Surrounding temperature, then storage at normal condition 4hrs.											
6	Vibration Test (Packaged)	1. Sine wave 10~55 Hz frequency (1 min) 2. The amplitude of vibration :1.5 mm 3. Each direction (X、Y、Z) duration for 2 Hrs											
7	Drop Test (Packaged)	<table border="1"> <thead> <tr> <th>Packing Weight (Kg)</th> <th>Drop Height (cm)</th> </tr> </thead> <tbody> <tr> <td>0 ~ 45.4</td> <td>122</td> </tr> <tr> <td>45.4 ~ 90.8</td> <td>76</td> </tr> <tr> <td>90.8 ~ 454</td> <td>61</td> </tr> <tr> <td>Over 454</td> <td>46</td> </tr> </tbody> </table>	Packing Weight (Kg)	Drop Height (cm)	0 ~ 45.4	122	45.4 ~ 90.8	76	90.8 ~ 454	61	Over 454	46	
		Packing Weight (Kg)	Drop Height (cm)										
0 ~ 45.4	122												
45.4 ~ 90.8	76												
90.8 ~ 454	61												
Over 454	46												
		Drop direction :※ 1 corner / 3 edges / 6 sides etch 1times											

5. PRECAUTION RELATING PRODUCT HANDLING

5.1 SAFETY

- 5.1.1 If the LCD panel breaks , be careful not to get the liquid crystal to touch your skin.
- 5.1.2 If the liquid crystal touches your skin or clothes , please wash it off immediately by using soap and water.

5.2 HANDLING

- 5.2.1 Avoid any strong mechanical shock which can break the glass.
- 5.2.2 Avoid static electricity which can damage the CMOS LSI—When working with the module , be sure to ground your body and any electrical equipment you may be using.
- 5.2.3 Do not remove the panel or frame from the module.
- 5.2.4 The polarizing plate of the display is very fragile. So , please handle it very carefully ,do not touch , push or rub the exposed polarizing with anything harder than an HB pencil lead (glass , tweezers , etc.)
- 5.2.5 Do not wipe the polarizing plate with a dry cloth , as it may easily scratch the surface of plate.
- 5.2.6 Do not touch the display area with bare hands , this will stain the display area.
- 5.2.7 Do not use ketonics solvent & aromatic solvent. Use with a soft cloth soaked with a cleaning naphtha solvent.
- 5.2.8 To control temperature and time of soldering is $320\pm 10^{\circ}\text{C}$ and 3-5 sec.
- 5.2.9 To avoid liquid (include organic solvent) stained on LCM .

5.3 STORAGE

- 5.3.1 Store the panel or module in a dark place where the temperature is $25^{\circ}\text{C} \pm 5^{\circ}\text{C}$ and the humidity is below 65% RH.
- 5.3.2 Do not place the module near organics solvents or corrosive gases.
- 5.3.3 Do not crush , shake , or jolt the module.

5.4 TERMS OF WARRANTY

- 5.4.1 Applicable warrant period
The period is within thirteen months since the date of shipping out under normal using and storage conditions.

- 5.4.2 Unaccepted responsibility
This product has been manufactured to your company's specification as a part for use in your company's general electronic products. It is guaranteed to perform according to delivery specifications. For any other use apart from general electronic equipment , we cannot take responsibility if the product is used in nuclear power control equipment , aerospace equipment , fire and security systems or any other applications in which there is a direct risk to human life and where extremely high levels of reliability are required.

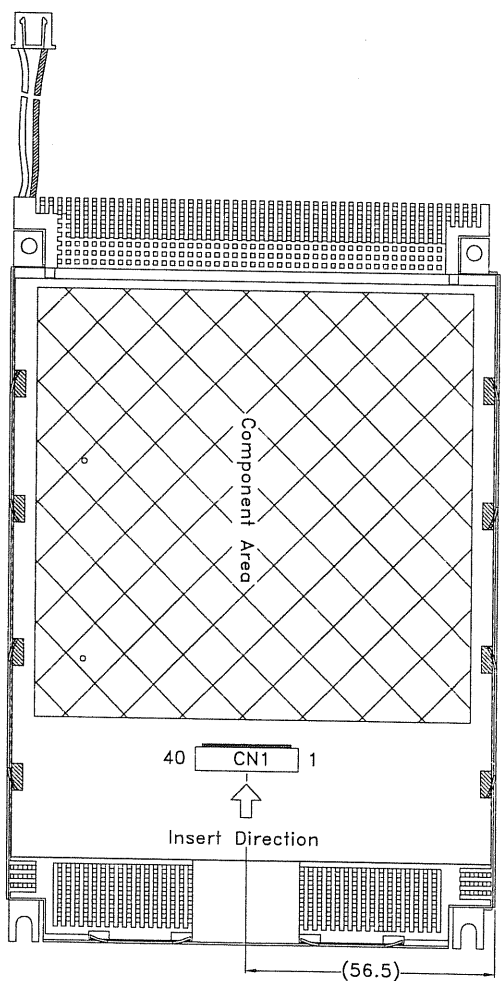
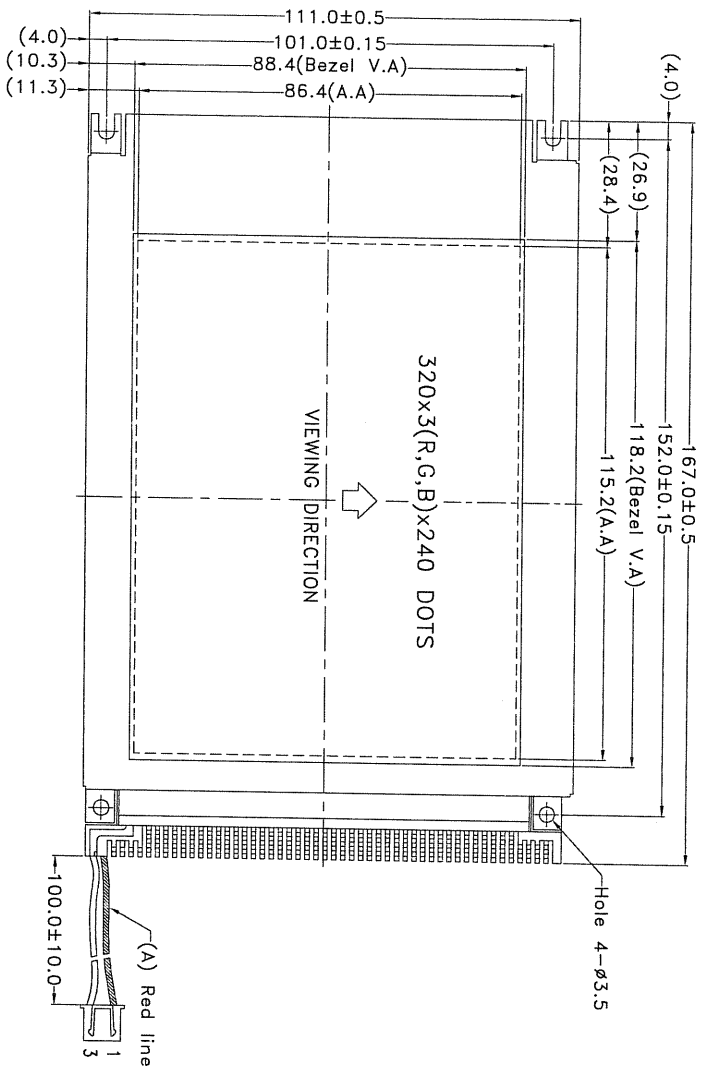

Recommended design rule for CN1 FPC
SCALE: 1.5/1

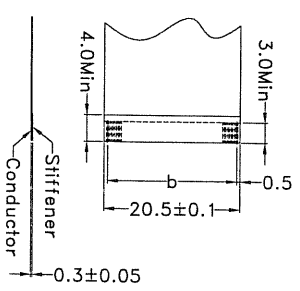

- Note:
- 1.The tolerance unless classified $\pm 0.3\text{mm}$
 - 2.LCD type: α -si TFT
 - 3.LCD mode:Positive / Transmissive
 - 4.View direction:6 o'clock
 5. $T_{op} = -20^{\circ}\text{C} \sim 70^{\circ}\text{C}$, $T_{st} = -30^{\circ}\text{C} \sim 80^{\circ}\text{C}$
 6. $b = (P0.5 \times 39 = 19.5 \pm 0.05, W = 0.3 \pm 0.03)$
 7. CN1: IMSA-9637S-40Y905(Brm)
 8. PCB PAD PCB Component Area

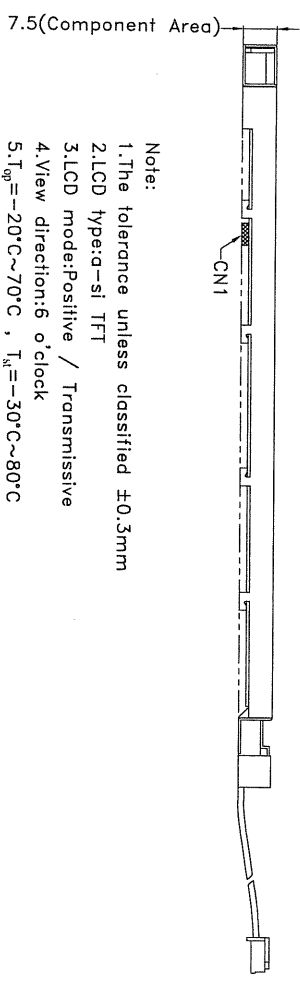

REV	DESCRIPTION	DATE

		SCALE:1/1.7	UNIT:mm	PAGE:1/1	久正光电股份有限公司 POWER TIP TECHNOLOGY CORPORATION			
圖面名稱	圖面編號	PH320240T-005-1-0	PH-06018-002	ED1	0	APPROVED	CHECKER	DRAWN

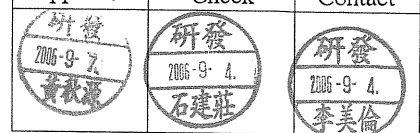

1. 包裝材料規格表 (Packaging Material) : (per carton)

No.	Item	Model	Dimensions (mm)	Quantity
1	成品 (LCM)	PH320240T-005-I-Q	167.0 X 111.0	28
2	靜電袋(1)	BAG240170ARABA	240 X 170	28
3	氣泡袋(2)	BAG170150AWBBA	170 X 150	28
4	A6隔板(3)	BX33800012BZBA	338 X 125 X 3	16
5	B6隔板(4)	BX29800012BZBA	293 X 125 X 3	4
6	海綿墊(5)	OTFOAM00005ABA	330 X 290 X 10	4
7	C4內盒(6)Product Box	BX36031014AABA	360 X 310 X 142	2
8	外紙箱(7)Carton	BX39432432CCBA	394 X 324 X 321	1
9				

2. 單箱數量規格表 (Packaging Specifications and Quantity) :

(1)Quantity Of Spacer : A6隔板 X 8 , B6隔板 X 2

(2)Total LCM quantity in carton : quantity per box 14 x no of boxes 2 = 28

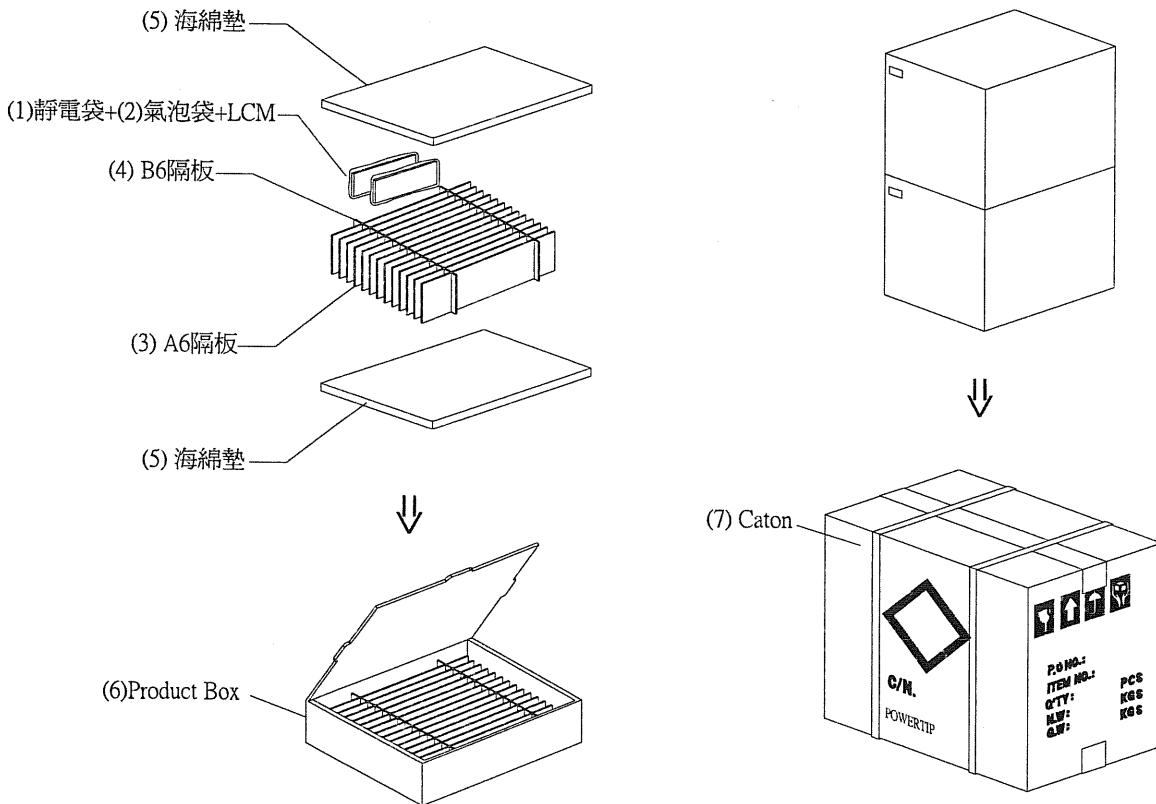

特 記 事 項 (REMARK)

1. Label Specifications :

MODEL:
LOT NO:
QUANTITY:
CHECK:

1. 每個間隔放2片模組，前後間隔不放置模組。(如示意圖)

放置格示意圖:

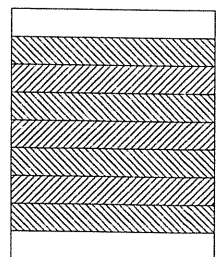

1. [Shaded] 模組 X 2pcs. 2. [White] 空格