



SPECIFICATIONS

CUSTOMER	:	CFR002
SAMPLE CODE	:	PS320240T-015-I-01
MASS PRODUCTION CODE	:	PH320240T-015-I-Q
SAMPLE VERSION	:	01
SPECIFICATIONS EDITION	:	003
DRAWING NO. (Ver.)	:	LMD-PH320240T-015-I-Q (Ver.002)
PACKAGING NO. (Ver.)	:	PKG-PH320240T-015-I-Q (Ver.001)

Customer Approved

Date:

Approved	Checked	Designer
廖志豪 Rex Liao	李厚憲 Sam Lee	李健弘 Lambert Lee

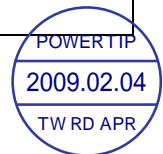

- Preliminary specification for design input
- Specification for sample approval

POWERTIP TECH. CORP.

Headquarters:

No.8, 6th Road, Taichung Industrial Park,
Taichung, Taiwan
台中市 407 工業區六路 8 號

TEL: 886-4-2355-8168

FAX: 886-4-2355-8166

E-mail: sales@powertip.com.tw

Http://www.powertip.com.tw

Contents

1. SPECIFICATIONS

- 1.1 Features
- 1.2 Mechanical Specifications
- 1.3 Absolute Maximum Ratings
- 1.4 DC Electrical Characteristics
- 1.5 Optical Characteristics
- 1.6 Backlight & LED Characteristics

2. MODULE STRUCTURE

- 2.1 Counter Drawing
- 2.2 Interface Pin Description
- 2.3 Timing Characteristics

3. QUALITY ASSURANCE SYSTEM

- 3.1 Quality Assurance Flow Chart
- 3.2 Inspection Specification

4. RELIABILITY TEST

- 4.1 Reliability Test Condition

5. PRECAUTION RELATING PRODUCT HANDLING

- 5.1 Safety
- 5.2 Handling
- 5.3 Storage
- 5.4 Terms of Warranty

Appendix : LCM Drawing
Packaging

1. SPECIFICATIONS

1.1 Features

Main LCD Panel

Item	Standard Value
Display Type	320(R · G · B) * 240 Dots
LCD Type	Normally white , Transmissive type
Screen size(inch)	3.5 inch
Viewing Direction	6 O'clock
Color configuration	RGB-Strip
Backlight	LED B/L
Interface	8-bits serial RGB interface
Driver IC	Himax: HX8238-A
ROHS	THIS PRODUCT CONFORMS THE ROHS OF PTC Detail information please refer web side : http://www.powertip.com.tw/news/LatestNews.asp

1.2 Mechanical Specifications

Item	Standard Value	Unit
Outline Dimension	76.9 (W) * 63.9(L) * 8.5 (H)(Max)	mm

LCD Panel

Item	Standard Value	Unit
Viewing Area	71.68 (W) * 54.16 (L)	mm
Active Area	70.08 (W) * 52.56 (L)	mm

Note : For detailed information please refer to LCM drawing

1.3 Absolute Maximum Ratings

Module

Item	Symbol	Condition	Min.	Max.	Unit
System Power Supply Voltage	VDDIO	VSS	-0.3	+4.0	V
Input Voltage	V_i	-	-0.3	5.0	V
Operating Temperature	T_{OP}	-	-20	+70	°C
Storage Temperature	T_{ST}	-	-30	+80	°C
Storage Humidity	H_D	$T_a < 40\text{ °C}$	20	90	%RH

1.4 DC Electrical Characteristics

Module

GND = 0V, $T_a = 25\text{ °C}$

Item	Symbol	Condition	Min.	Typ.	Max.	Unit
Power Supply Voltage	VDDIO	-	-	3.3	-	V
VCOM High Voltage	VCOMH	-	2.5	(3.6)	4.5	V
VCOM Low Voltage	VCOML	-	-3	(-2.4)	0	V
Input High Voltage	V_{IH1}	-	$0.8 * VDDIO$	-	VDDIO	V
Input Low Voltage	V_{IL1}	-	0	-	$0.2 * VDDIO$	V
Output High Voltage	V_{OH1}	$I_{OH} = -0.1\text{mA}$	$0.9 * VDDIO$	-	VDD	V
Output Low Voltage	V_{OL1}	$I_{OL} = 0.1\text{mA}$	0	-	$0.1 * VDDIO$	V
Supply Current	IDDIO	VDDIO = 3.3 V Pattern=full display*1	-	200	300	mA

Note1:Maximum current display

1.5 Optical Characteristics

TFT LCD Panel

VDDIO =3.3V, Ta=25°C

Item	Symbol	Condition	Min.	Typ.	Max.	unit		
Response time	Tr + Tf	Ta = 25°C θX, θY = 0°	-	35	53	ms	Note2	
Viewing angle	Top	θY+	CR ≥ 10	-	45	-	Deg.	Note4
	Bottom	θY-		-	50	-		
	Left	θX-		-	50	-		
	Right	θX+		-	50	-		
Contrast ratio	CR		200	250	-	-	Note3	
Color of CIE Coordinate (With B/L)	White	X	Ta = 25°C θX , θY = 0°	0.25	0.30	0.35	-	Note1
		Y		0.30	0.35	0.40		
	Red	X		0.53	0.59	0.63		
		Y		0.30	0.35	0.40		
	Green	X		0.28	0.33	0.38		
		Y		0.55	0.60	0.65		
	Blue	X		0.09	0.14	0.19		
		Y		0.04	0.09	0.14		
Average Brightness Pattern=white display	IV	IF= 20mA	150	180	-	cd/m ²	Note1	
Uniformity	B	IF= 20mA	70	-	-	%	Note1	

Note1:

1 : $B = B(\min) / B(\max) \times 100\%$

2 : Measurement Condition for Optical Characteristics:

a : Environment: 25 ±5 / 60±20%R.H , no wind , dark room below 10 Lux at typical lamp current and typical operating frequency.

b : Measurement Distance: 500 ± 50 mm , (θ= 0°)

c : Equipment: TOPCON BM-7 fast , (field 1°) , after 10 minutes operation.

d : The uncertainty of the C.I.E coordinate measurement ±0.01 , Average Brightness ± 4%

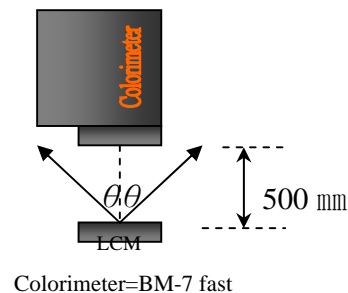

Note2: Definition of response time:

The output signals of photo detector are measured when the input signals are changed from "black" to "white"(falling time) and from "white" to "black"(rising time), respectively. The response time is defined as the time interval between the 10% and 90% of Amplitudes.

Refer to figure as below:

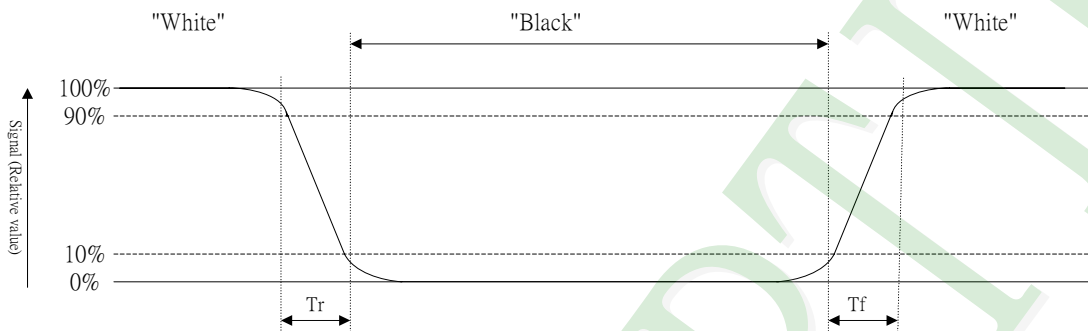

Note3: Definition of contrast ratio:

Contrast ratio is calculated with the following formula

$$\text{Contrast ratio (CR)} = \frac{\text{Photo detector output when LCD is at "White" state}}{\text{Photo detector output when LCD is at "Black" state}}$$

Note4: Definition of viewing angle:

Refer to figure as below:

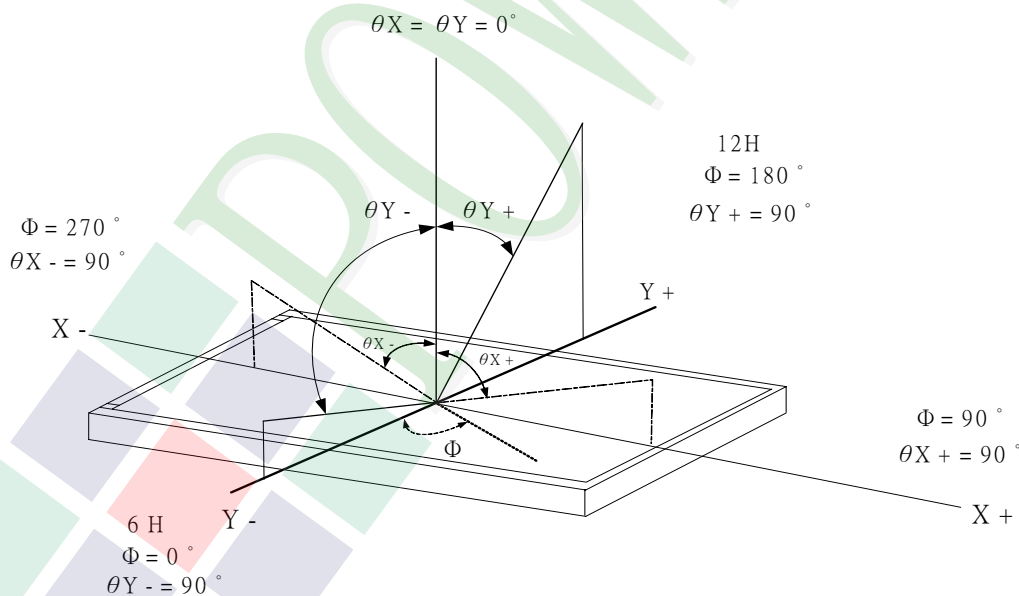

1.6 Backlight & LED Characteristics

LCD Module with LED Backlight

Maximum Ratings

Item	Symbol	Conditions	Min.	Max.	Unit
Forward Voltage	VF	Ta =25°C	-	24	V
Forward Current	IF	Ta =25°C	-	30	mA
Reverse Voltage	VR	Ta =25°C	-	30	V
Power Dissipation	PD	Ta =25°C	-	720	mW

Electrical / Optical Characteristics

Item	Symbol	Conditions	Min.	Typ.	Max.	Unit
Forward Voltage	VF	IF= 20mA	-	19.8	21	V
Average Brightness	IV		3500	4300	--	cd/m ²
Color of CIE Coordinate	X		--	0.29	--	-
	Y		--	0.29	--	
Color	White					

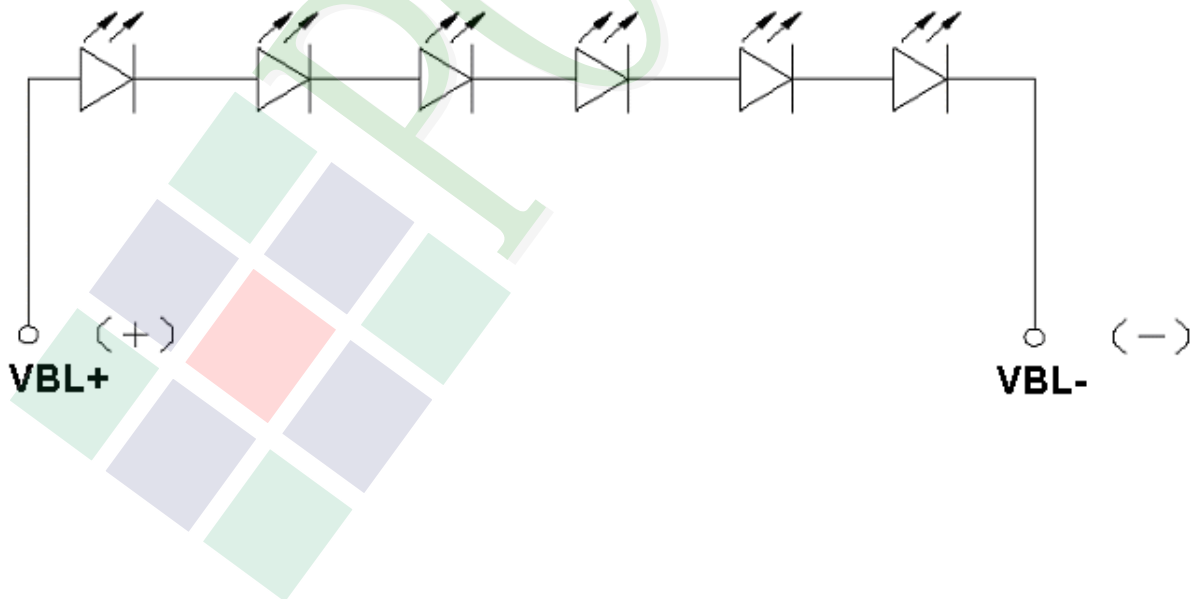

2. MODULE STRUCTURE

2.1 Counter Drawing

2.1.1 LCM Mechanical Diagram

* See Appendix

2.1.2 Block Diagram

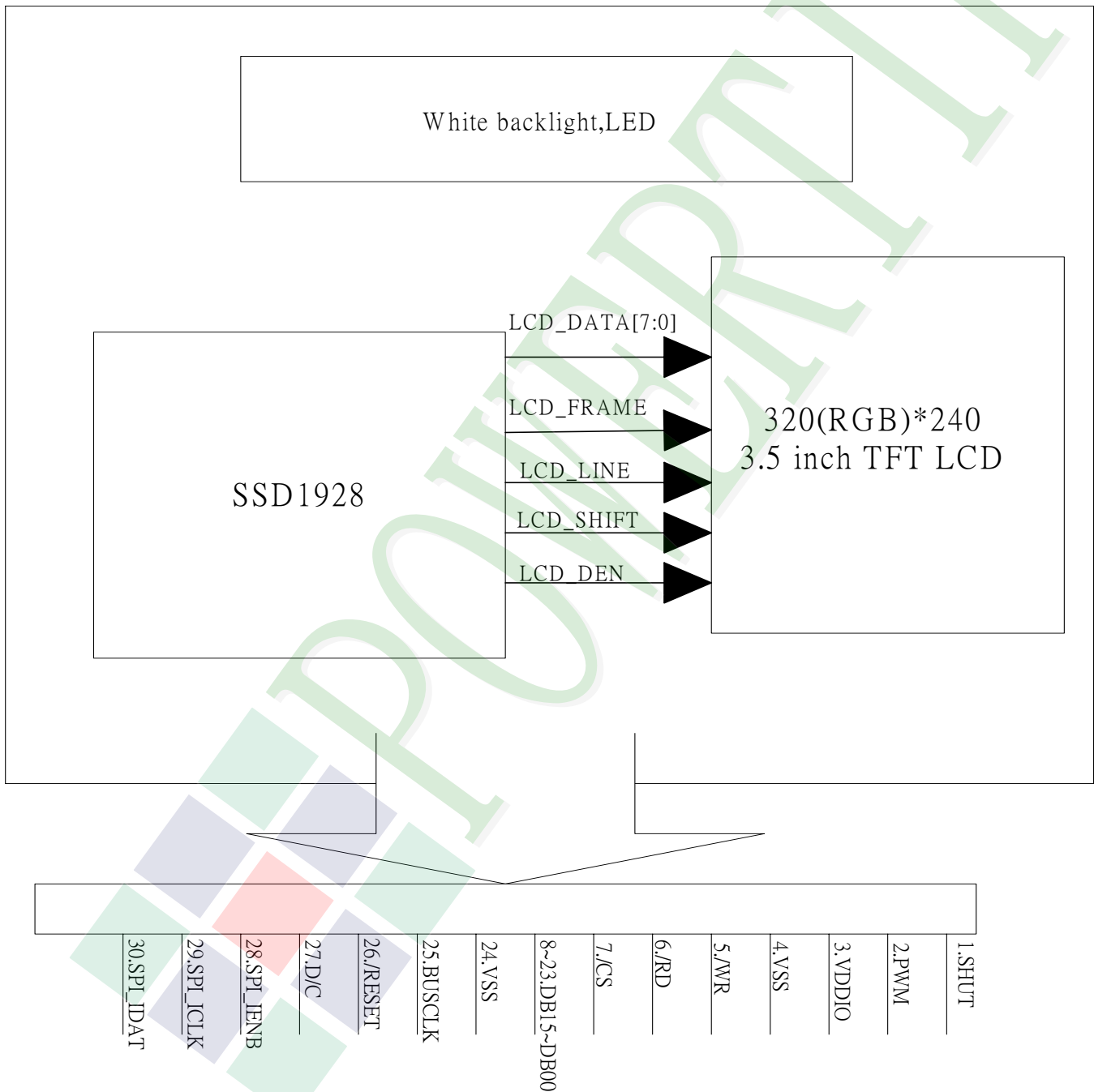

2.2 Interface Pin Description

Pin No	Symbol	Function
1	SHUT	Display shut down pin to put the driver into sleep mode. A sharp falling edge must be provided to such pin when IC power on. Internal pull low. - Connect to VDDIO for sleep mode - Connect to VSS for normal operating mode (Refer to Power Up Sequence)
2	PWM	B/L PWM.
3	VDDIO	Power Supply Voltage.
4	VSS	Ground.
5	/WR	For 8080, this is an input of write enable signal.
6	/RD	For 8080, this is an input of read enable signal.
7	/CS	Chip select input.
8	DB15	Data bus.
9	DB14	Data bus.
10	DB13	Data bus.
11	DB12	Data bus.
12	DB11	Data bus.
13	DB10	Data bus.
14	DB09	Data bus.
15	DB08	Data bus.
16	DB07	Data bus.
17	DB06	Data bus.
18	DB05	Data bus.
19	DB04	Data bus.
20	DB03	Data bus.
21	DB02	Data bus.
22	DB01	Data bus.

Pin No	Symbol	Function
23	DB00	Data bus.
24	VSS	Ground.
25	BUSCLK	Clock source input.
26	/RESET	Reset.
27	D/C	For 8080, this pin is used as data / command select.
28	SPI_IENB	Serial port data enable signal.
29	SPI_ICLK	Serial data clock.
30	SPI_IDAT	Serial data.
31	NC	Not Connect
32	NC	Not Connect
33	NC	Not Connect
34	NC	Not Connect
35	NC	Not Connect
36	NC	Not Connect
37	NC	Not Connect
38	NC	Not Connect
39	NC	Not Connect
40	NC	Not Connect

2.3 Timing Characteristics

2.3.1 SPI Read

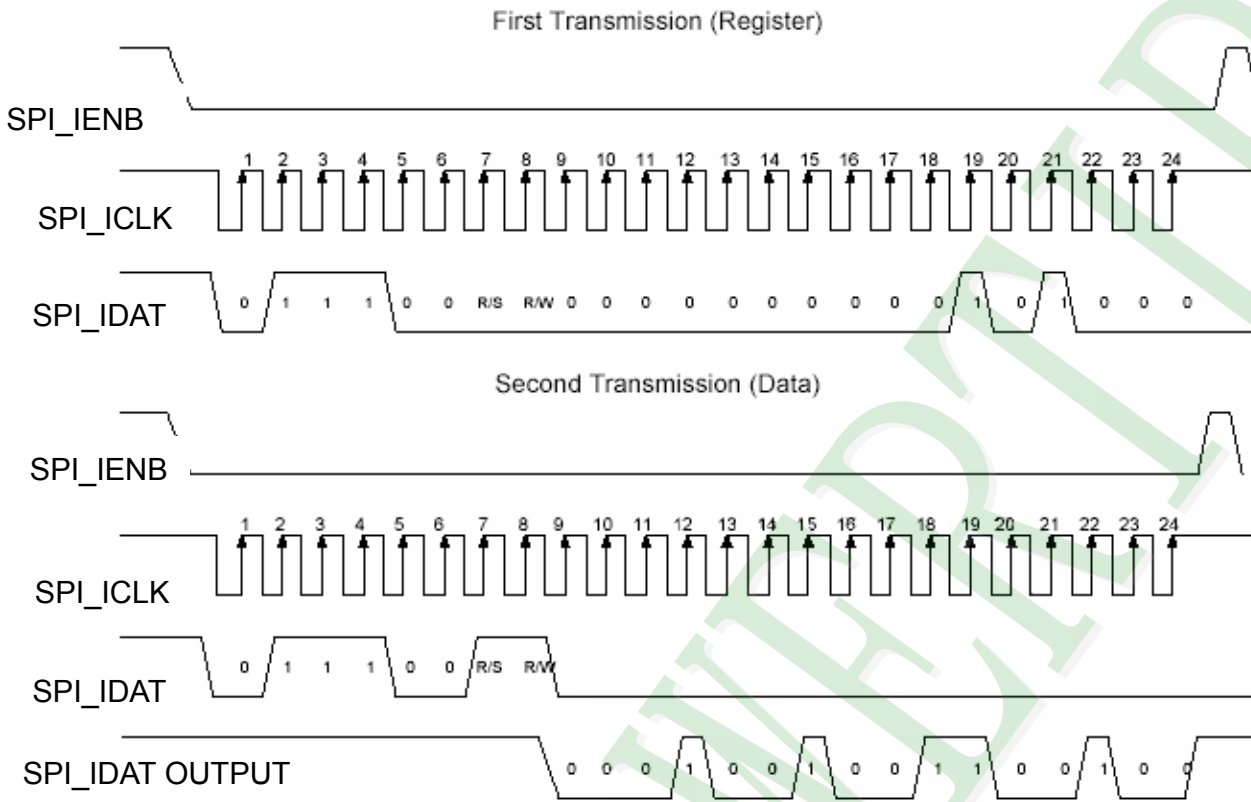

Note: The example Read "0x1264h" from register R28h.

SPI interface Timing Diagram & Read SPI Example

2.3.2 SPI Write

First Transmission (Register)

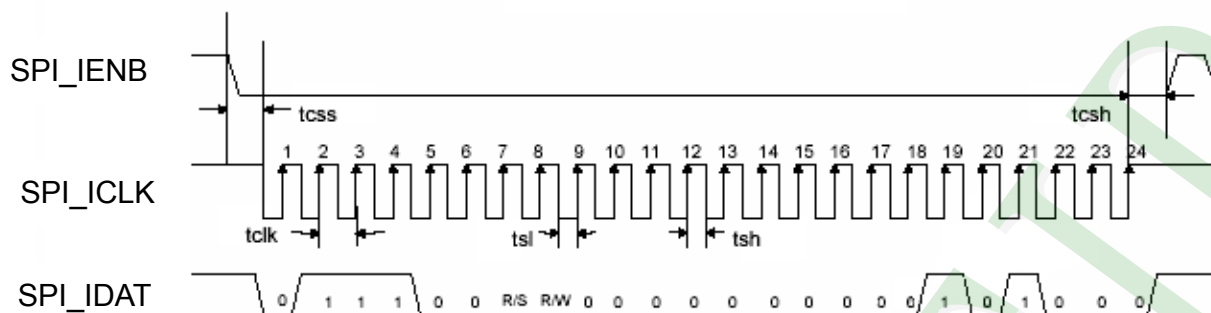

Second Transmission (Data)

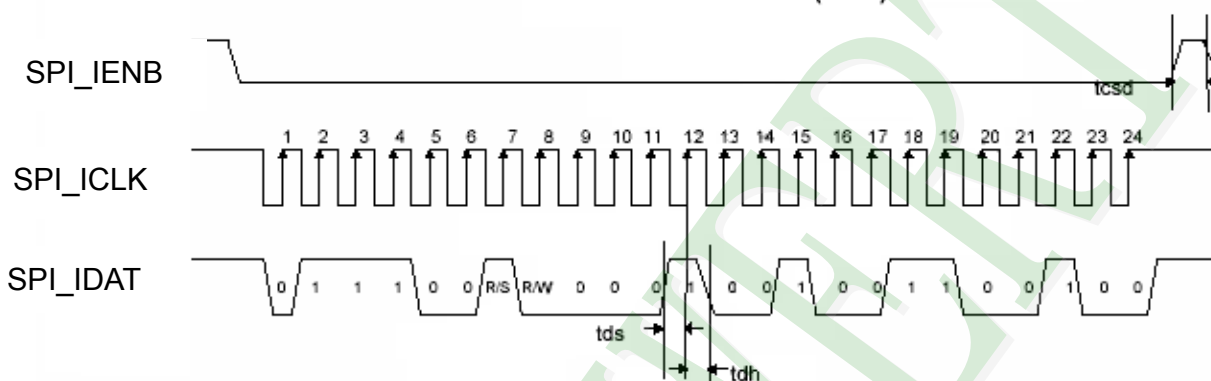

Note: The example writes "0x1264h" to register R28h.
SPID connected to VSS.

SPI interface Timing Diagram & Write SPI Example

2.3.3 SPI Timing Table

Characteristics	Symbol	Min.	Typ.	Max.	Unit
Serial Clock Frequency	fdck	-	-	20	MHz
Serial Clock Cycle Time	tclk	50	-	-	ns
Clock Low Width	tsl	25	-	-	ns
Clock High Width	tsh	25	-	-	ns
Clock Rising Time	trs	-	-	30	ns
Clock Falling Time	tfl	-	-	30	ns
Chip Select Setup Time	tcss	0	-	-	ns
Chip Select Hold Time	tcsh	10	-	-	ns
Chip Select High Delay Time	tcshd	20	-	-	ns
Data Setup Time	tds	5	-	-	ns
Data Hold Time	tdh	10	-	-	ns

SPI Timing

2.4 Power Sequence

2.4.1 Power up sequence

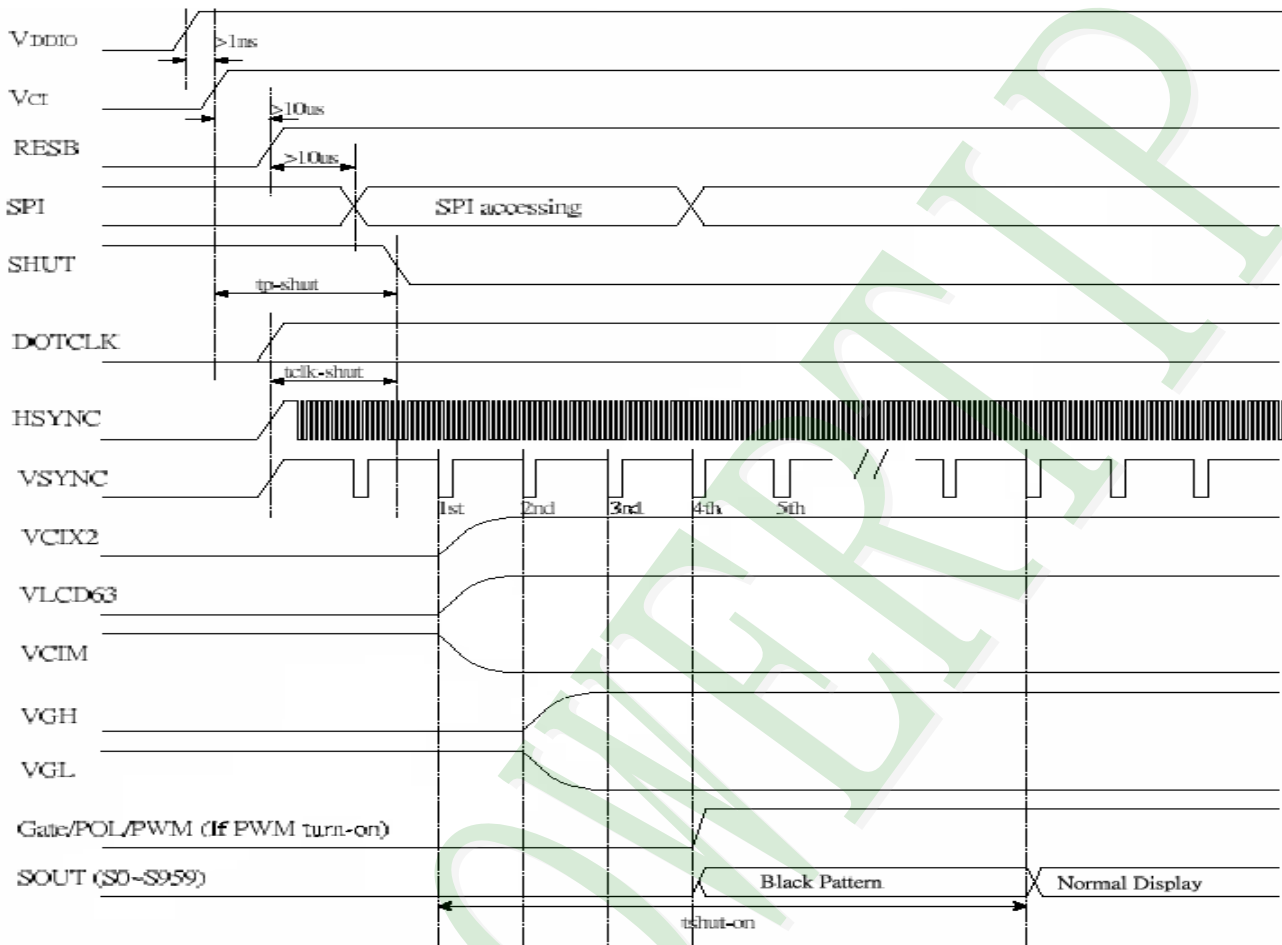

Characteristics	Symbol	Min.	Typ.	Max.	Unit
VCI/ VDDIO on to falling edge of SHUT	$tp-shut$	1	-	-	us
DOTCLK to falling edge of SHUT	$tclk-shut$ (Note1)	1	-	-	clk
Falling edge of SHUT to display start - 1 line: 408 clk - 1 frame: 262 line - DOTCLK = 6.5MHz	$tshut-on$ (Note2)	-	10	-	frame

Power Up Sequence

Note1: It is necessary to input DOTCLK before the falling edge of SHUT.

Note2: Display starts at 10th falling edge of VSTNC after the falling edge of SHUT. The display starts at the falling edge of VSYNC which is determined by BLT[1:0] of R04h.

Note : The voltage of VDD be boost from VDDIO.

2.4.2 Power down sequence

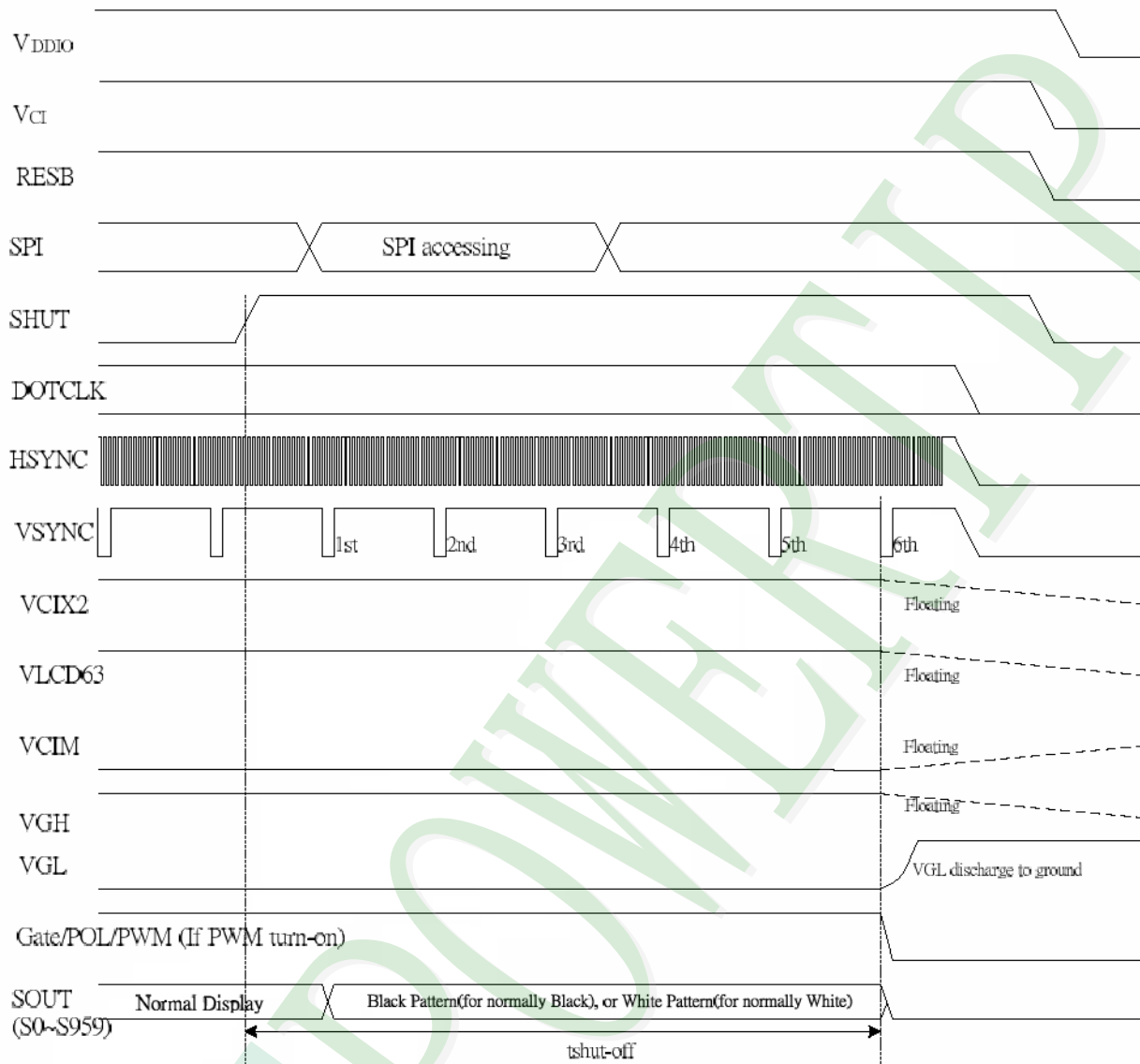

Characteristics	Symbol	Min.	Typ.	Max.	Unit
Rising edge of SHUT to display off - 1 line: 408 clk - 1 frame: 262 line - DOTCLK = 6.5MHz	tshut-off	-	-	6	frame

Note: DOTCLK must be maintained at least 6 frames after the rising edge of SHUT.
 Display become off at the 6nd falling edge of VSTNC after the falling edge of SHUT.
 If RESET signal is necessary for power down, provide it after the 6-frames-cycle of the SHUT period.

Power Down Sequence

Note : The voltage of VDD be boost from VDDIO.

3. QUALITY ASSURANCE SYSTEM

3.1 Quality Assurance Flow Chart

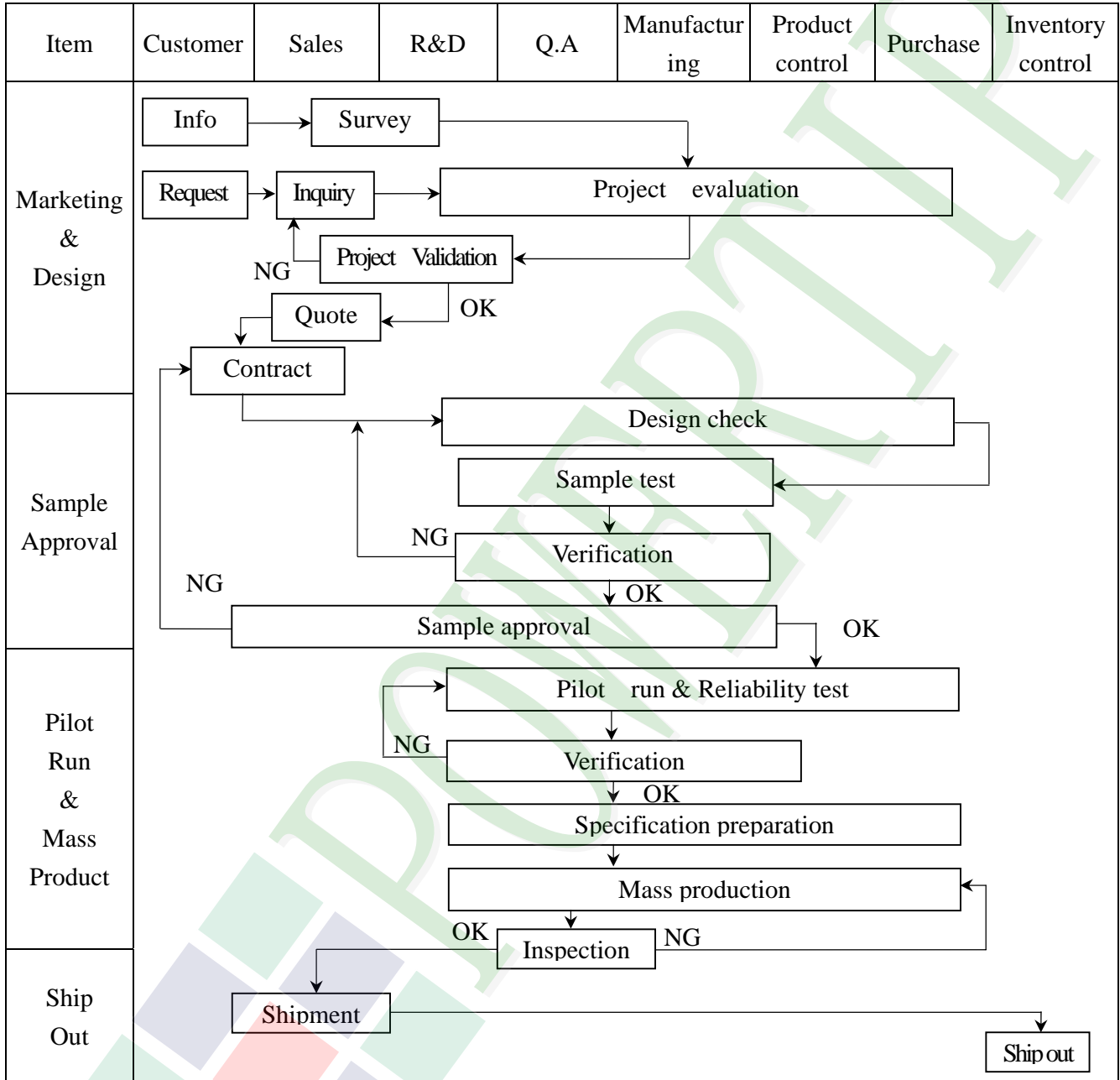

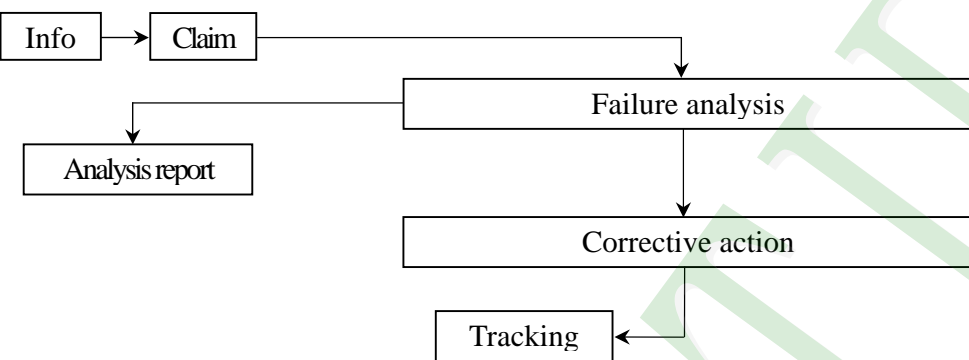
Item	Customer	Sales	R&D	Q.A	Manufacturing	Product control	Purchase	Inventory control
Sales Service	 <pre> graph TD Info[Info] --> Claim[Claim] Claim --> Failure[Failure analysis] Claim --> Report[Analysis report] Failure --> Action[Corrective action] Action --> Tracking[Tracking] </pre>							
Q.A Activity	1. ISO 9001 Maintenance Activities 3. Equipment calibration 5. Standardization Management				2. Process improvement proposal 4. Education And Training Activities			

3.2 Inspection Specification

- ◆Scope : The document shall be applied to TFT-LCD Module for 3.5" ~10" (Ver. 03).
- ◆Inspection Standard : MIL-STD-105E Table Normal Inspection Single Sampling Level II.
- ◆Equipment : Gauge , MIL-STD , Powertip Tester , Sample
- ◆Defect Level : Major Defect AQL : 0.4 ; Minor Defect AQL : 1.5
- ◆OUT Going Defect Level : Sampling.
- ◆Standard of the product appearance test :

a. Manner of appearance test :

- (1). The test best be under 20W×2 fluorescent light , and distance of view must be at 30 cm.
- (2). The test direction is base on about around 45° of vertical line.

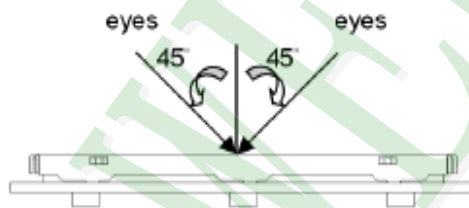

(3). Definition of area.

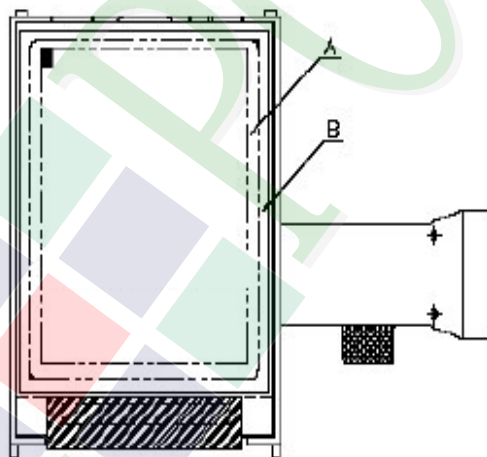

A area : viewing area

B area : Outside of viewing area

(4). Standard of inspection : (Unit : mm)

◆ Specification For TFT-LCD Module 3.5" ~10" :
(Ver. 03)

NO	Item	Criterion	Level										
01	Product condition	1. 1 The part number is inconsistent with work order of production.	Major										
		1. 2 Mixed product types.	Major										
		1. 3 Assembled in inverse direction.	Major										
02	Quantity	2. 1 The quantity is inconsistent with work order of production.	Major										
03	Outline dimension	3. 1 Product dimension and structure must conform to structure diagram.	Major										
04	Electrical Testing	4. 1 Missing line character and icon.	Major										
		4. 2 No function or no display.	Major										
		4. 3 Display malfunction.	Major										
		4. 4 LCD viewing angle defect.	Major										
		4. 5 Current consumption exceeds product specifications.	Major										
05	Dot defect (Bright dot , Dark dot) On -display	<table border="1" style="margin-left: auto; margin-right: auto;"> <thead> <tr> <th>Item</th> <th>Acceptance (Q'ty)</th> </tr> </thead> <tbody> <tr> <td>Bright Dot</td> <td>≤ 4</td> </tr> <tr> <td>Dark Dot</td> <td>≤ 5</td> </tr> <tr> <td>Joint Dot</td> <td>≤ 3</td> </tr> <tr> <td>Total</td> <td>≤ 7</td> </tr> </tbody> </table>	Item	Acceptance (Q'ty)	Bright Dot	≤ 4	Dark Dot	≤ 5	Joint Dot	≤ 3	Total	≤ 7	Minor
		Item	Acceptance (Q'ty)										
		Bright Dot	≤ 4										
		Dark Dot	≤ 5										
		Joint Dot	≤ 3										
Total	≤ 7												
5. 1 Inspection pattern : full white , full black , Red , Green and blue screens.													
5. 2 It is defined as dot defect if defect area $> 1/2$ dot.													
5. 3 The distance between two dot defect ≥ 5 mm.													

◆ Specification For TFT-LCD Module 3.5" ~10" :
(Ver. 03)

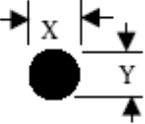
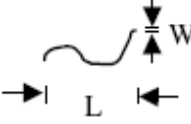
NO	Item	Criterion	Level																																							
06	<p>Black or white dot、scratch、contamination</p> <p>Round type</p>  <p>$\Phi = (x+y) / 2$</p> <p>Line type</p> 	<p>6.1 Round type (Non-display or display) :</p> <table border="1" data-bbox="494 488 1252 817"> <thead> <tr> <th rowspan="2">Dimension (diameter : Φ)</th> <th colspan="2">Acceptance (Q'ty)</th> </tr> <tr> <th>A area</th> <th>B area</th> </tr> </thead> <tbody> <tr> <td>$\Phi \leq 0.25$</td> <td>Ignore</td> <td rowspan="4">Ignore</td> </tr> <tr> <td>$0.25 < \Phi \leq 0.50$</td> <td>5</td> </tr> <tr> <td>$\Phi > 0.50$</td> <td>0</td> </tr> <tr> <td>Total</td> <td>5</td> </tr> </tbody> </table> <p>6.2 Line type(Non-display or display) :</p> <table border="1" data-bbox="454 967 1289 1400"> <thead> <tr> <th colspan="2">Dimension</th> <th colspan="2">Acceptance (Q'ty)</th> </tr> <tr> <th>Length (L)</th> <th>Width (W)</th> <th>A area</th> <th>B area</th> </tr> </thead> <tbody> <tr> <td>---</td> <td>$W \leq 0.03$</td> <td>Ignore</td> <td rowspan="4">Ignore</td> </tr> <tr> <td>$L \leq 10.0$</td> <td>$0.03 < W \leq 0.05$</td> <td>4</td> </tr> <tr> <td>$L \leq 5.0$</td> <td>$0.05 < W \leq 0.10$</td> <td>2</td> </tr> <tr> <td>---</td> <td>$W > 0.10$</td> <td>As round type</td> </tr> <tr> <td colspan="2">Total</td> <td>5</td> <td></td> </tr> </tbody> </table>	Dimension (diameter : Φ)	Acceptance (Q'ty)		A area	B area	$\Phi \leq 0.25$	Ignore	Ignore	$0.25 < \Phi \leq 0.50$	5	$\Phi > 0.50$	0	Total	5	Dimension		Acceptance (Q'ty)		Length (L)	Width (W)	A area	B area	---	$W \leq 0.03$	Ignore	Ignore	$L \leq 10.0$	$0.03 < W \leq 0.05$	4	$L \leq 5.0$	$0.05 < W \leq 0.10$	2	---	$W > 0.10$	As round type	Total		5		Minor
Dimension (diameter : Φ)	Acceptance (Q'ty)																																									
	A area	B area																																								
$\Phi \leq 0.25$	Ignore	Ignore																																								
$0.25 < \Phi \leq 0.50$	5																																									
$\Phi > 0.50$	0																																									
Total	5																																									
Dimension		Acceptance (Q'ty)																																								
Length (L)	Width (W)	A area	B area																																							
---	$W \leq 0.03$	Ignore	Ignore																																							
$L \leq 10.0$	$0.03 < W \leq 0.05$	4																																								
$L \leq 5.0$	$0.05 < W \leq 0.10$	2																																								
---	$W > 0.10$	As round type																																								
Total		5																																								
07	Polarizer Bubble	<table border="1" data-bbox="486 1482 1257 1915"> <thead> <tr> <th rowspan="2">Dimension (diameter : Φ)</th> <th colspan="2">Acceptance (Q'ty)</th> </tr> <tr> <th>A area</th> <th>B area</th> </tr> </thead> <tbody> <tr> <td>$\Phi \leq 0.25$</td> <td>Ignore</td> <td rowspan="5">Ignore</td> </tr> <tr> <td>$0.25 < \Phi \leq 0.50$</td> <td>4</td> </tr> <tr> <td>$0.50 < \Phi \leq 0.80$</td> <td>1</td> </tr> <tr> <td>$\Phi > 0.80$</td> <td>0</td> </tr> <tr> <td>Total</td> <td>5</td> </tr> </tbody> </table>	Dimension (diameter : Φ)	Acceptance (Q'ty)		A area	B area	$\Phi \leq 0.25$	Ignore	Ignore	$0.25 < \Phi \leq 0.50$	4	$0.50 < \Phi \leq 0.80$	1	$\Phi > 0.80$	0	Total	5	Minor																							
Dimension (diameter : Φ)	Acceptance (Q'ty)																																									
	A area	B area																																								
$\Phi \leq 0.25$	Ignore	Ignore																																								
$0.25 < \Phi \leq 0.50$	4																																									
$0.50 < \Phi \leq 0.80$	1																																									
$\Phi > 0.80$	0																																									
Total	5																																									

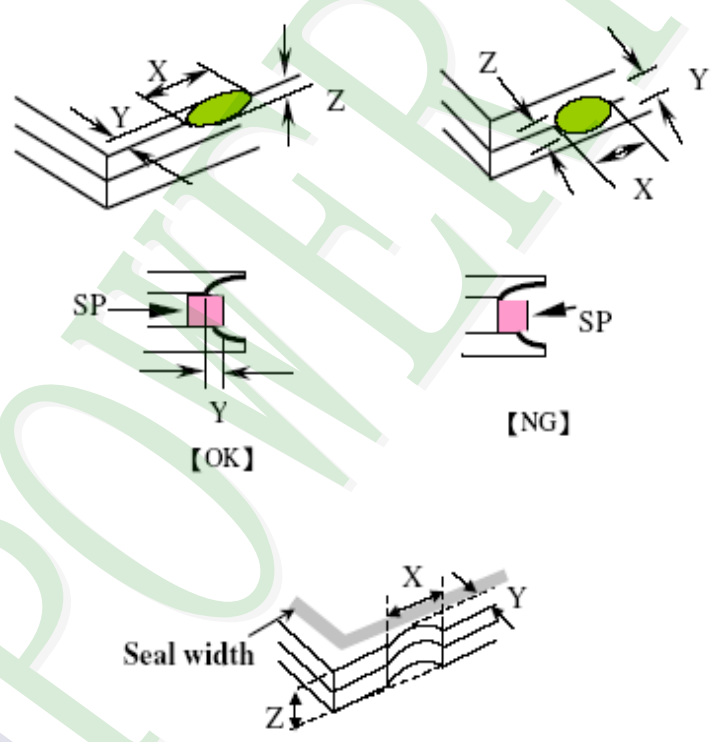
NO	Item	Criterion	Level						
08	The crack of glass	<p>Symbols :</p> <p>X : The length of crack Z : The thickness of crack t : The thickness of glass</p> <p>Y : The width of crack. W : terminal length a : LCD side length</p>	Minor						
		<p>8.1 General glass chip :</p> <p>8.1.1 Chip on panel surface and crack between panels:</p>  <table border="1" data-bbox="534 1612 1284 1904"> <thead> <tr> <th>X</th> <th>Y</th> <th>Z</th> </tr> </thead> <tbody> <tr> <td>$\leq a$</td> <td>Crack can't enter viewing area</td> <td>$\leq 1/2 t$</td> </tr> <tr> <td>$\leq a$</td> <td>Crack can't exceed the half of SP width.</td> <td>$1/2 t < Z \leq 2 t$</td> </tr> </tbody> </table>		X	Y	Z	$\leq a$	Crack can't enter viewing area	$\leq 1/2 t$
X	Y	Z							
$\leq a$	Crack can't enter viewing area	$\leq 1/2 t$							
$\leq a$	Crack can't exceed the half of SP width.	$1/2 t < Z \leq 2 t$							

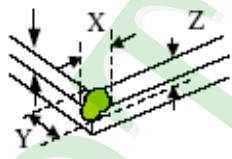
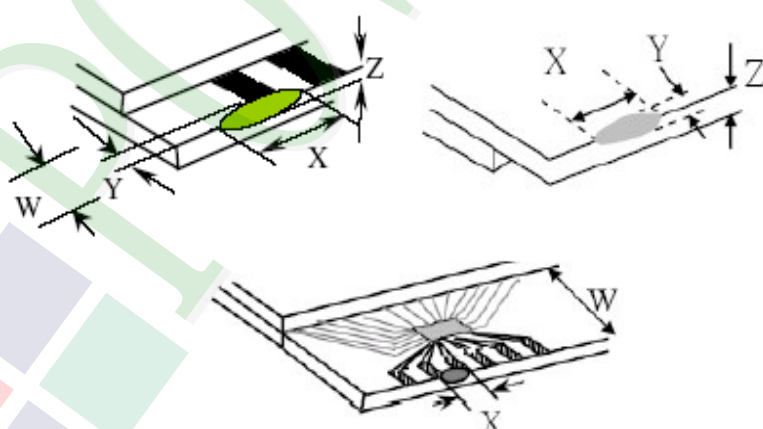
NO	Item	Criterion	Level									
08	The crack of glass	<p>Symbols :</p> <p>X : The length of crack Y : The width of crack. Z : The thickness of crack t : The thickness of glass W : terminal length a : LCD side length</p> <p>8.1.2 Corner crack :</p>  <table border="1" data-bbox="507 806 1252 1093"> <thead> <tr> <th>X</th> <th>Y</th> <th>Z</th> </tr> </thead> <tbody> <tr> <td>$\leq 1/5 a$</td> <td>Crack can't enter viewing area</td> <td>$Z \leq 1/2 t$</td> </tr> <tr> <td>$\leq 1/5 a$</td> <td>Crack can't exceed the half of SP width.</td> <td>$1/2 t < Z \leq 2 t$</td> </tr> </tbody> </table>	X	Y	Z	$\leq 1/5 a$	Crack can't enter viewing area	$Z \leq 1/2 t$	$\leq 1/5 a$	Crack can't exceed the half of SP width.	$1/2 t < Z \leq 2 t$	Minor
		X	Y	Z								
$\leq 1/5 a$	Crack can't enter viewing area	$Z \leq 1/2 t$										
$\leq 1/5 a$	Crack can't exceed the half of SP width.	$1/2 t < Z \leq 2 t$										
<p>8.2 Protrusion over terminal :</p> <p>8.2.1 Chip on electrode pad :</p>  <table border="1" data-bbox="542 1702 1260 1881"> <thead> <tr> <th></th> <th>X</th> <th>Y</th> <th>Z</th> </tr> </thead> <tbody> <tr> <td>Front</td> <td>$\leq a$</td> <td>$\leq 1/2 W$</td> <td>$\leq t$</td> </tr> <tr> <td>Back</td> <td>$\leq a$</td> <td>$\leq W$</td> <td>$\leq 1/2 t$</td> </tr> </tbody> </table>		X	Y	Z	Front	$\leq a$	$\leq 1/2 W$	$\leq t$	Back	$\leq a$	$\leq W$	$\leq 1/2 t$
	X	Y	Z									
Front	$\leq a$	$\leq 1/2 W$	$\leq t$									
Back	$\leq a$	$\leq W$	$\leq 1/2 t$									

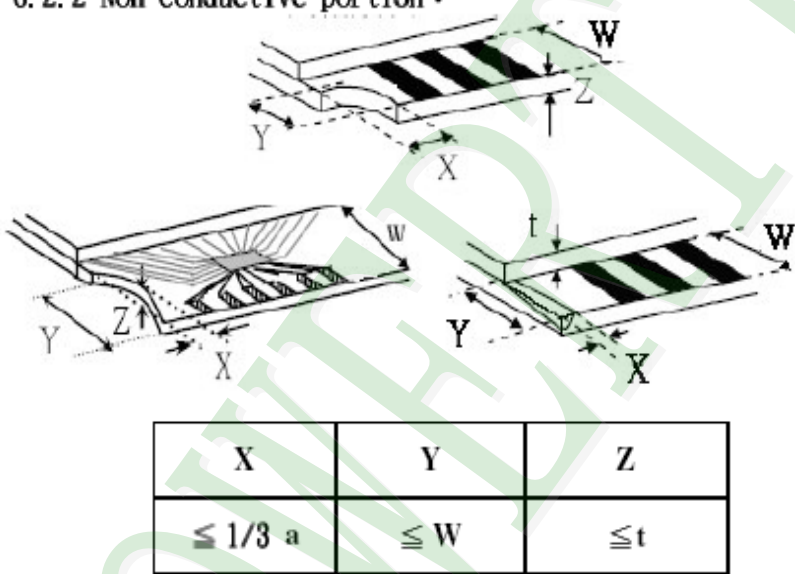
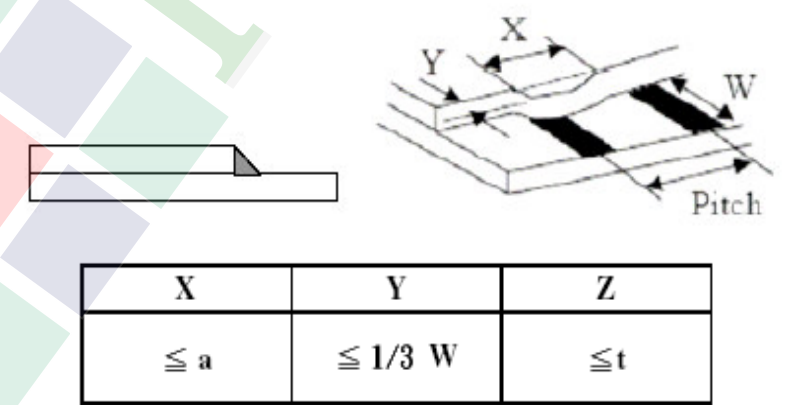
NO	Item	Criterion	Level
08	The crack of glass	<p>Symbols :</p> <p>X : The length of crack Y : The width of crack. Z : The thickness of crack W : terminal length t : The thickness of glass a : LCD side length</p>	Minor
		<p>8.2.2 Non-conductive portion :</p>  <p>⊙ If the chipped area touches the ITO terminal, over 2/3 of the ITO must remain and be inspected according to electrode terminal specifications.</p> <p>8.2.3 Glass remain :</p> 	

◆Specification For TFT-LCD Module 3.5" ~10" :
(Ver. 03)

NO	Item	Criterion	Level
09	Backlight elements	9. 1 Backlight can't work normally.	Major
		9. 2 Backlight doesn't light or color is wrong.	Major
		9. 3 Illumination source flickers when lit.	Major
10	General appearance	10. 1 Pin type , quantity , dimension must match type in structure diagram.	Major
		10. 2 No short circuits in components on PCB or FPC .	Major
		10. 3 Parts on PCB or FPC must be the same as on the production characteristic chart .There should be no wrong parts , missing parts or excess parts.	Major
		10. 4 Product packaging must the same as specified on packaging specification sheet.	Minor
		10. 5 The folding and peeled off in polarizer are not acceptable.	Minor
		10. 6 The PCB or FPC between B/L assembled distance(PCB or FPC) is ≤ 1.5 mm.	Minor

4. RELIABILITY TEST

4.1 Reliability Test Condition

Ver.03

NO.	TEST ITEM	TEST CONDITION											
1	High Temperature Storage Test	Keep in +80 ±2°C 96 hrs Surrounding temperature, then storage at normal condition 4hrs.											
2	Low Temperature Storage Test	Keep in -30 ±2°C 96 hrs Surrounding temperature, then storage at normal condition 4hrs.											
3	High Temperature / High Humidity Storage Test	Keep in +60°C / 90% R.H duration for 96 hrs Surrounding temperature, then storage at normal condition 4hrs. (Excluding the polarizer)											
4	ESD Test	Air Discharge: Apply 2 KV with 5 times Discharge for each polarity +/-	Contact Discharge: Apply 250 V with 5 times discharge for each polarity +/-										
		1. Temperature ambience : 15°C ~ 35°C 2. Humidity relative : 30% ~ 60% 3. Energy Storage Capacitance(Cs+Cd) : 150pF±10% 4. Discharge Resistance(Rd) : 330Ω±10% 5. Discharge, mode of operation : Single Discharge (time between successive discharges at least 1 sec) (Tolerance if the output voltage indication : ±5%)											
5	Temperature Cycling Storage Test	$ \begin{array}{ccccccc} -20^{\circ}\text{C} & \rightarrow & +25^{\circ}\text{C} & \rightarrow & +70^{\circ}\text{C} & \rightarrow & +25^{\circ}\text{C} \\ (30\text{mins}) & & (5\text{mins}) & & (30\text{mins}) & & (5\text{mins}) \\ \longleftarrow & & & & & & \longrightarrow \\ & & & & & & 10 \text{ Cycle} \end{array} $ Surrounding temperature, then storage at normal condition 4hrs.											
6	Vibration Test (Packaged)	1. Sine wave 10 55 Hz frequency (1 min) 2. The amplitude of vibration : 1.5 mm 3. Each direction (X、Y、Z) duration for 2 Hrs											
7	Drop Test (Packaged)	<table border="1"> <thead> <tr> <th>Packing Weight (Kg)</th> <th>Drop Height (cm)</th> </tr> </thead> <tbody> <tr> <td>0 ~ 45.4</td> <td>122</td> </tr> <tr> <td>45.4 ~ 90.8</td> <td>76</td> </tr> <tr> <td>90.8 ~ 454</td> <td>61</td> </tr> <tr> <td>Over 454</td> <td>46</td> </tr> </tbody> </table>		Packing Weight (Kg)	Drop Height (cm)	0 ~ 45.4	122	45.4 ~ 90.8	76	90.8 ~ 454	61	Over 454	46
		Packing Weight (Kg)	Drop Height (cm)										
0 ~ 45.4	122												
45.4 ~ 90.8	76												
90.8 ~ 454	61												
Over 454	46												
		Drop direction : ※1 corner / 3 edges / 6 sides each 1times											

5. PRECAUTION RELATING PRODUCT HANDLING

5.1 SAFETY

- 5.1.1 If the LCD panel breaks , be careful not to get the liquid crystal to touch your skin.
- 5.1.2 If the liquid crystal touches your skin or clothes , please wash it off immediately by using soap and water.

5.2 HANDLING

- 5.2.1 Avoid any strong mechanical shock which can break the glass.
- 5.2.2 Avoid static electricity which can damage the CMOS LSI—When working with the module , be sure to ground your body and any electrical equipment you may be using.
- 5.2.3 Do not remove the panel or frame from the module.
- 5.2.4 The polarizing plate of the display is very fragile. So , please handle it very carefully, do not touch , push or rub the exposed polarizing with anything harder than an HB pencil lead (glass , tweezers , etc.)
- 5.2.5 Do not wipe the polarizing plate with a dry cloth , as it may easily scratch the surface of plate.
- 5.2.6 Do not touch the display area with bare hands , this will stain the display area.
- 5.2.7 Do not use ketonics solvent & aromatic solvent. Use with a soft cloth soaked with a cleaning naphtha solvent.
- 5.2.8 To control temperature and time of soldering is $320 \pm 10^{\circ}\text{C}$ and 3-5 sec.
- 5.2.9 To avoid liquid (include organic solvent) stained on LCM

5.3 STORAGE

- 5.3.1 Store the panel or module in a dark place where the temperature is $25^{\circ}\text{C} \pm 5^{\circ}\text{C}$ and the humidity is below 65% RH.
- 5.3.2 Do not place the module near organics solvents or corrosive gases.
- 5.3.3 Do not crush , shake , or jolt the module.

5.4 TERMS OF WARRANTY

- 5.4.1 Applicable warrant period
The period is within thirteen months since the date of shipping out under normal using and storage conditions.
- 5.4.2 Unaccepted responsibility
This product has been manufactured to your company's specification as a part for use in your company's general electronic products. It is guaranteed to perform according to delivery specifications. For any other use apart from general electronic equipment, we cannot take responsibility if the product is used in nuclear power control equipment, aerospace equipment , fire and security systems or any other applications in which there is a direct risk to human life and where extremely high levels of reliability are required.

A B C D E F G H

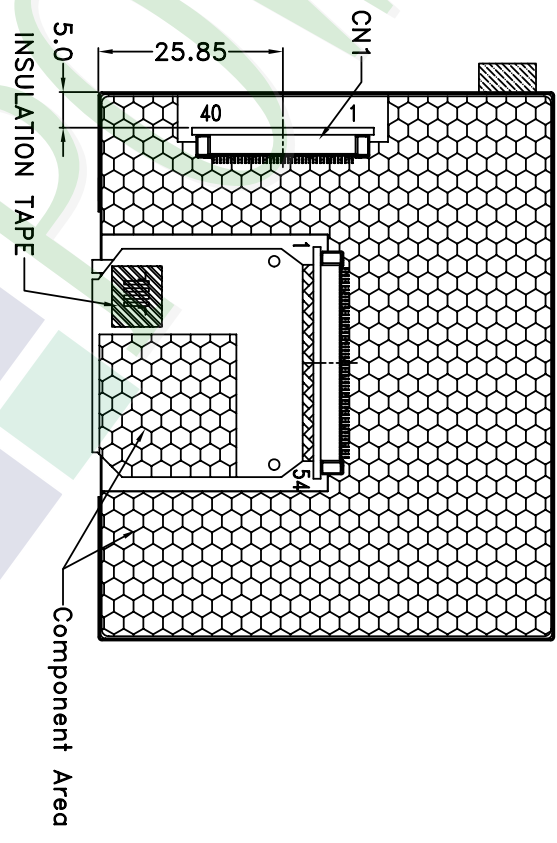
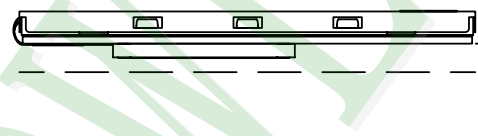
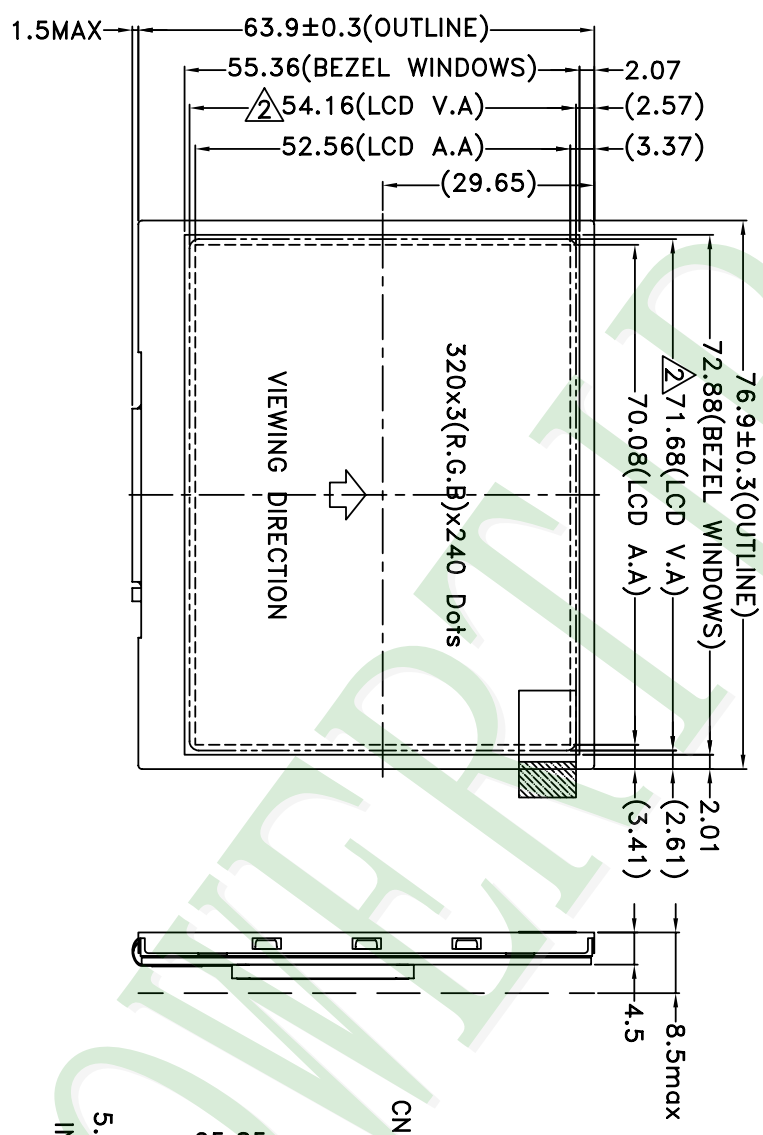

- NOTES:
- 1.LCD TYPE:q-SI TFT
 - 2.LCD DISPLAY:TRANSMISSIVE
 - 3 VIEW DIRECTION: 6 O'CLOCK
 - 4.The tolerance unless classified $\pm 0.3\text{mm}$
 - 5.CN1:IMSA-9637S-40Y923

006				PART NO:	PH320240T-015-I-Q	久正光電股份有限公司 POWER TIP TECHNOLOGY CORPORATION	Design Mag Check Stone Approve Linda	Unit MM Scale 1:1	Surface Material Thickness Quantity	Precision Level Tolerances (mm) 1 ~ 4 4 ~ 16 16 ~ 63 63 ~ 250 250 ~ 1000
005				DRAWING NAME :	LMD-PH320240T-015-I-Q					
004					TITLE:	LCD Module Drawing				
003										
002	Add LCD V.A dim	Mag	2009/01/21							
001	Modify Pin Description	Stone	2008/02/29							
0	NEW DRAWING	Stone	2007/12/28							
REV		REV BY	DATE							

Ver.001

Documents NO.

PKG-PH320240T-015-I-Q

LCM包裝規格書

LCM Packaging Specifications

Approve

Check

Contact

Oliver

Mag

Stone

1. 包裝材料規格表 (Packaging Material) : (per carton)

No.	Item	Model	Dimensions (mm)	1Pcs Weight	Quantity	Total Weight
1	成品 (LCM)	PH320240T-015-I-Q	76.9 X 63.9	0.045	288	12.96
2	靜電袋(1)Antistatic Bag	BAG150120ARABA	150 X 120	0.0018	288	0.5184
3	氣泡袋(2)Bubble Bag	BAG240100AWBBA	240 X 100	0.001	288	0.288
4	A2隔板(3)A2 Partition	BX29300070BMBA	293 X 70 X 2.5	0.011	88	0.968
5	B2隔板(4)B2 Partition	BX24500070BLBA	245 X 70 X 2.5	0.01	32	0.32
6	氣泡紙(5)Bubble Sheet	BAG280240BWABA	280 X 240	0.006	16	0.096
7	C2內盒(6)Product Box	BX31025580AABA	310 X 255 X 80	0.221	8	1.768
8	外紙箱(7)Carton	BX52732536CCBA	527 X 325 X 360	1.092	1	1.092
9						

2. 一整箱總重量 (Total LCD Weight in carton) : 18.43 Kg±10%

3. 單箱數量規格表 (Packaging Specifications and Quantity) :

(1)Quantity Of Spacer : A2隔板 X 11 , B2隔板 X 4

(2)Total LCM quantity in carton : quantity per box 36 x no of boxes 8 = 288

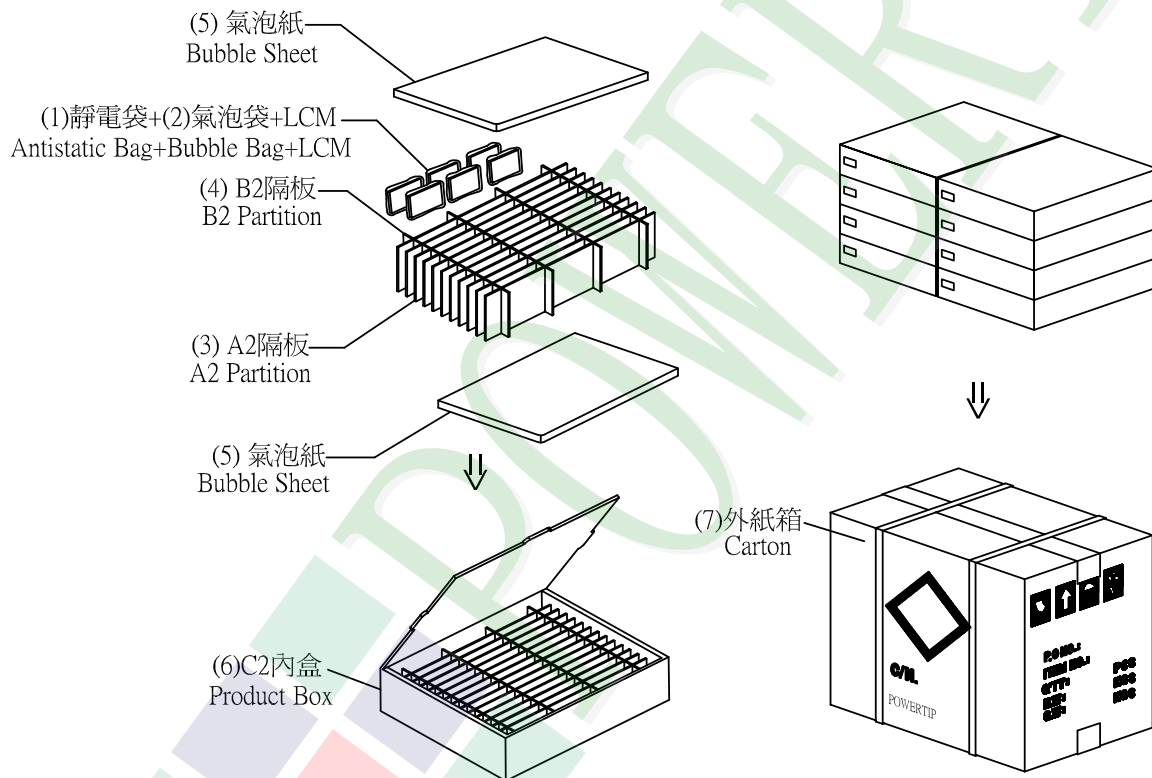

特記事項 (REMARK)

1. Label Specifications :

MODEL:
LOT NO:
QUANTITY:
CHECK: