



SPECIFICATIONS

CUSTOMER	:	PTC
SAMPLE CODE	:	SH800480T-013-I01Q
MASS PRODUCTION CODE	:	PH800480T-013-I01Q
SAMPLE VERSION	:	02
SPECIFICATIONS EDITION	:	005
DRAWING NO. (Ver.)	:	LMD-PH800480T-013-I01Q (Ver.003)
PACKAGING NO. (Ver.)	:	PKG-PH800480T-013-I01Q (Ver.001)

Customer Approved

Date:

Approved	Checked	Designer
黃秋源 Oliver Huang	李健弘 Lambert Lee	黃俊清 Ackey Huang

- Preliminary specification for design input
 Specification for sample approval



POWERTIP TECH. CORP.

Headquarters:

No.8, 6th Road, Taichung Industrial Park,
Taichung, Taiwan
台中市 407 工業區六路 8 號

TEL: 886-4-2355-8168
FAX: 886-4-2355-8166

E-mail: sales@powertip.com.tw
[Http://www.powertip.com.tw](http://www.powertip.com.tw)

History of Version

Date (mm / dd / yyyy)	Ver.	Edi.	Description	Page	Design by
09/06/2012	01	001	New Drawing.	-	Ackey
09/24/2012	01	002	New Sample.	-	Ackey
12/07/2012	01	003	Modify Touch Panel Dimension.	Appendix	Ackey
01/23/2013	02	004	Second Sample.	Appendix	Ackey
03/07/2013	02	005	Update Inspection Specification.	21	Ackey

Total: 27 Page

Contents

1. SPECIFICATIONS

- 1.1 Features
- 1.2 Mechanical Specifications
- 1.3 Absolute Maximum Ratings
- 1.4 DC Electrical Characteristics
- 1.5 Optical Characteristics
- 1.6 Backlight Characteristics
- 1.7 Touch Panel Characteristics

2. MODULE STRUCTURE

- 2.1 Counter Drawing
 - 2.1.1 LCM Mechanical Diagram
 - 2.1.2 Block Diagram
- 2.2 Interface Pin Description
- 2.3 Timing Characteristics
 - 2.3.1 Signal AC Characteristics
 - 2.3.2 Input Timing Setting
 - 2.3.3 Power On/Off Characteristics

3. QUALITY ASSURANCE SYSTEM

- 3.1 Quality Assurance Flow Chart
- 3.2 Inspection Specification

4. RELIABILITY TEST

- 4.1 Reliability Test Condition

5. PRECAUTION RELATING PRODUCT HANDLING

- 5.1 Safety
- 5.2 Handling
- 5.3 Storage
- 5.4 Terms of Warranty

Appendix : LCM Drawing
LCM Packaging Specifications

1. SPECIFICATIONS

1.1 Features

Item	Standard Value
Display Type	800 * (RGB) * 480
LCD Type	a-Si TFT , Normally white , Transmissive type
Screen size(inch)	7.0 inch
Viewing Direction	6 O'clock
Color configuration	Anti-Glare
Backlight Type	LED B/L
Weight	163 g
Interface	RGB Interface
ROHS	THIS PRODUCT CONFORMS THE ROHS OF PTC Detail information please refer web side : http://www.powertip.com.tw/news.php?area_id_view=1085560481/

1.2 Mechanical Specifications

Item	Standard Value	Unit
Outline Dimension	164.9 (W) * 100.0 (L) * 4.9 (H)	mm

LCD panel

Item	Standard Value	Unit
Active Area	154.08 (W) * 85.92 (L)	mm

Touch panel

Item	Standard Value	Unit
Active Area	155.2 (W) * 88.24 (L)	mm

Note : For detailed information please refer to LCM drawing.

1.3 Absolute Maximum Ratings

Module

Item	Symbol	Condition	Min.	Max.	Unit	Remark
Power Supply Voltage	DV _{DD}	GND=0	-0.3	5.0	V	-
	AV _{DD}		6.5	13.5	V	
	V _{GH}		-0.3	40	V	
	V _{GL}	AGND=0	-20	0.3	V	
	V _{GH} - V _{GL}	-	0	40	V	
Operating Temperature	T _{OP}	Excluded T/P	-20	60	°C	
Storage Temperature	T _{ST}	Excluded T/P	-30	70	°C	

The absolute maximum rating values of this product are not allowed to be exceeded at any times. Should a module be used with any of the absolute maximum ratings exceeded, the characteristics of the module may not be recovered, or in an extreme case, the module may be permanently destroyed.

1.4 DC Electrical Characteristics

Module

GND = 0V, Ta = 25°C

Item	Symbol	Min.	Typ.	Max.	Unit	Remark
Supply Voltage	DV _{DD}	3.0	3.3	3.6	V	-
	V _{GH}	15.3	16.0	16.7		
	V _{GL}	-7.7	-7.0	-6.3		
	AV _{DD}	10.2	10.4	10.6		
VCOM	V _{COM}	-	3.9	-	V	
Input signal Voltage	V _{IH}	0.7DV _{DD}	-	DV _{DD}	V	
	V _{IL}	0	-	0.3DV _{DD}		
Supply Current	IDD	-	80	-	mA	Pattern= Full display
		-	80	120		Pattern= Black *1

Note1: Maximum current display.

1.5 Optical Characteristics

TFT LCD Module

DV_{DD} = 3.3 V, Ta=25°C

Item		Symbol	Condition	Min.	Typ.	Max.	unit	
Response time	Rise	Tr	Ta = 25°C θX, θY = 0°	-	10	20	ms	Note 2
	Fall	Tf		-	15	30		
Viewing angle	Top	θY+	CR ≥ 10	40	50	-	Deg.	Note 4
	Bottom	θY-		60	70	-		
	Left	θX-		60	70	-		
	Right	θX+		60	70	-		
Contrast ratio		CR		200	250	-		Note 3
Color of CIE Coordinate (With B/L & touch panel)	White	X	Ta = 25°C θX, θY = 0°	0.24	0.29	0.34	-	Note1
		Y		0.25	0.30	0.35		
	Red	X		0.51	0.56	0.61		
		Y		0.29	0.34	0.39		
	Green	X		0.28	0.33	0.38		
		Y		0.52	0.57	0.62		
	Blue	X		0.09	0.14	0.19		
		Y		0.02	0.07	0.12		
Average Brightness Pattern=white display (With B/L & touch panel)*1		IV	-	200	250	-	cd/m ²	Note1
Uniformity (With B/L & touch panel)*2		△B	-	70	-	-	%	Note1

Note 1:

*1 : $\Delta B = B(\min) / B(\max) * 100\%$

*2 : Measurement Condition for Optical Characteristics:

a : Environment: 25 ±5 / 60±20%R.H , no wind , dark room below 10 Lux at typical lamp current and typical operating frequency.

b : Measurement Distance: 500 ± 50 mm , ($\theta = 0^\circ$)

c : Equipment: TOPCON BM-7 fast , (field 1°) , after 10 minutes operation.

d : The uncertainty of the C.I.E coordinate measurement ±0.01 , Average Brightness ± 4%

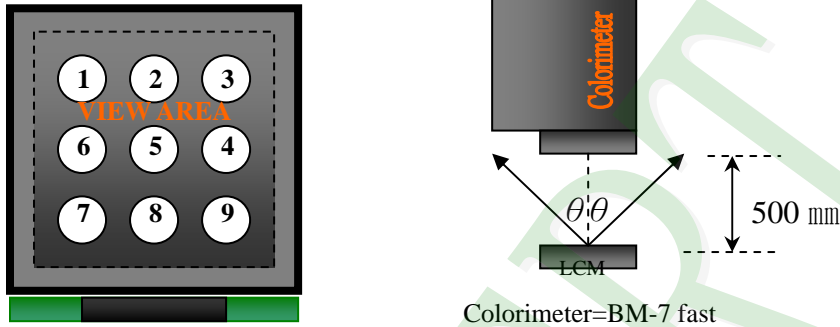

To be measured at the center area of panel with a viewing cone of 1° by Topcon luminance meter BM-7, after 10 minutes operation (module)

Note2: Definition of response time:

The output signals of photo detector are measured when the input signals are changed from "black" to "white"(falling time) and from "white" to "black"(rising time), respectively. The response time is defined as the time interval between the 10% and 90% of Amplitudes.

Refer to figure as below:

Normally White



Normally Black

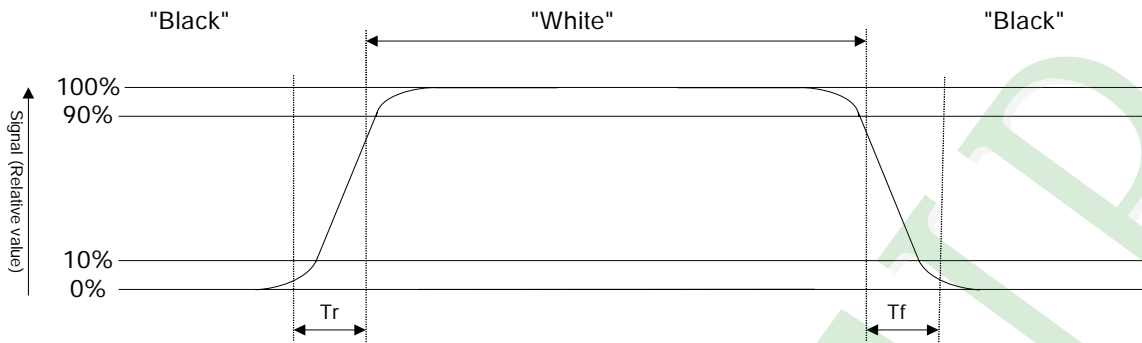

Note3: Definition of contrast ratio:

Contrast ratio is calculated with the following formula

$$\text{Contrast ratio (CR)} = \frac{\text{Photo detector output when LCD is at "White" state}}{\text{Photo detector output when LCD is at "Black" state}}$$

Note4: Definition of viewing angle:

Refer to figure as below:

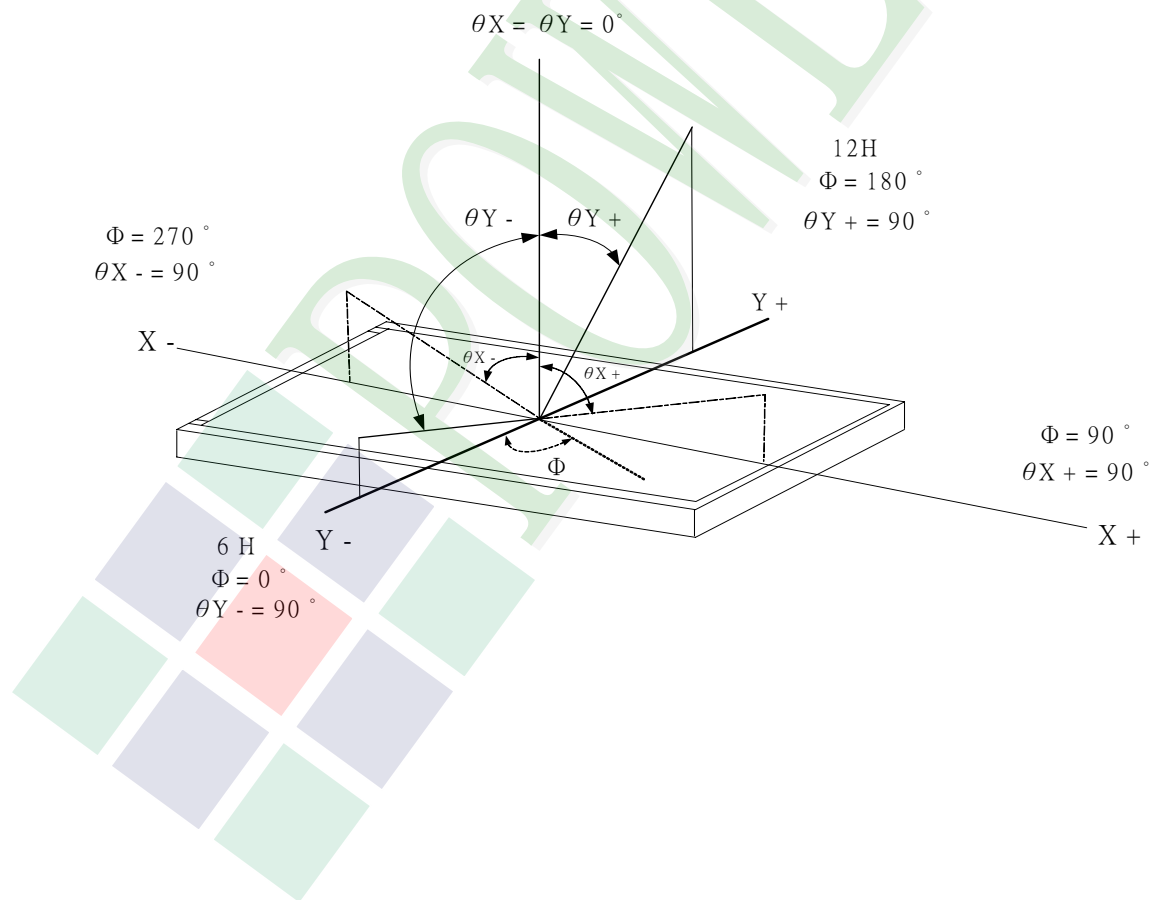

1.6 Backlight Characteristics

Maximum Ratings

Item	Symbol	Min.	Max.	Unit	Remark
LED Forward Current	I_F	25		mA	One LED
LED Reverse Voltage	V_R	1.2		V	

Electrical / Optical Characteristics

Item	Symbol	Min.	Typ.	Max.	Unit	Remark
LED Voltage	V_L	9.3	9.9	10.5	V	Note1
LED Current	I_L	140	160	180	mA	-
LED life time	-	20000	-	-	H _r	Note2

Note 1: The LED Supply Voltage is defined by the number of LED at $T_a=25^\circ\text{C}$ and $I_L=180\text{mA}$.

Note 2: The "LED life time" is defined as the module brightness decrease to 50% original brightness at $T_a=25^\circ\text{C}$ and $I_L=160\text{mA}$. The LED lifetime could be decreased if operating I_L is larger than 160mA.

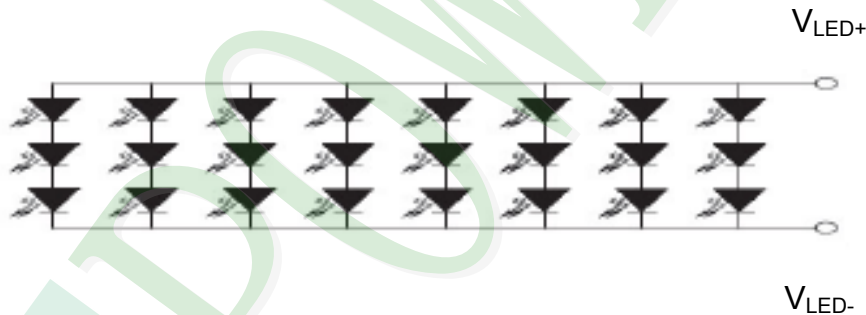

1.7 Touch Screen Characteristic

Item	Specification
Input Method	Stylus or Finger.
ITO Glass	Sheet Resistance:400±100Ω
ITO Film	Hard-Coating & Anti-glare Sheet Resistance:400±100Ω
Operating Temperature	-10 ~60 ,20~85%RH(Non Condensing)
Storage Temperature	-20 ~70 ,10~90%RH(Non Condensing)
¥	3H pencil, pressure 1N/45
Hitting Life	≥ 1,000,000 times
Writing Life	≥ 100,000 times
Insulation	≥ 20MΩ/25V(DC)
Transparency	≥ 78%
Linearity	X ≤ 1.5%, Y ≤ 1.5%
Operating Force	20-100g
Chattering	≤ 10ms
Impact Resistance	13.0φDIA. Steel Ball/9g Height=30cm
Static load resistance	500g within 30 cm ² area for 30sec

2. MODULE STRUCTURE

2.1 Counter Drawing

2.1.1 LCM Mechanical Diagram

* See Appendix

2.1.2 Block Diagram

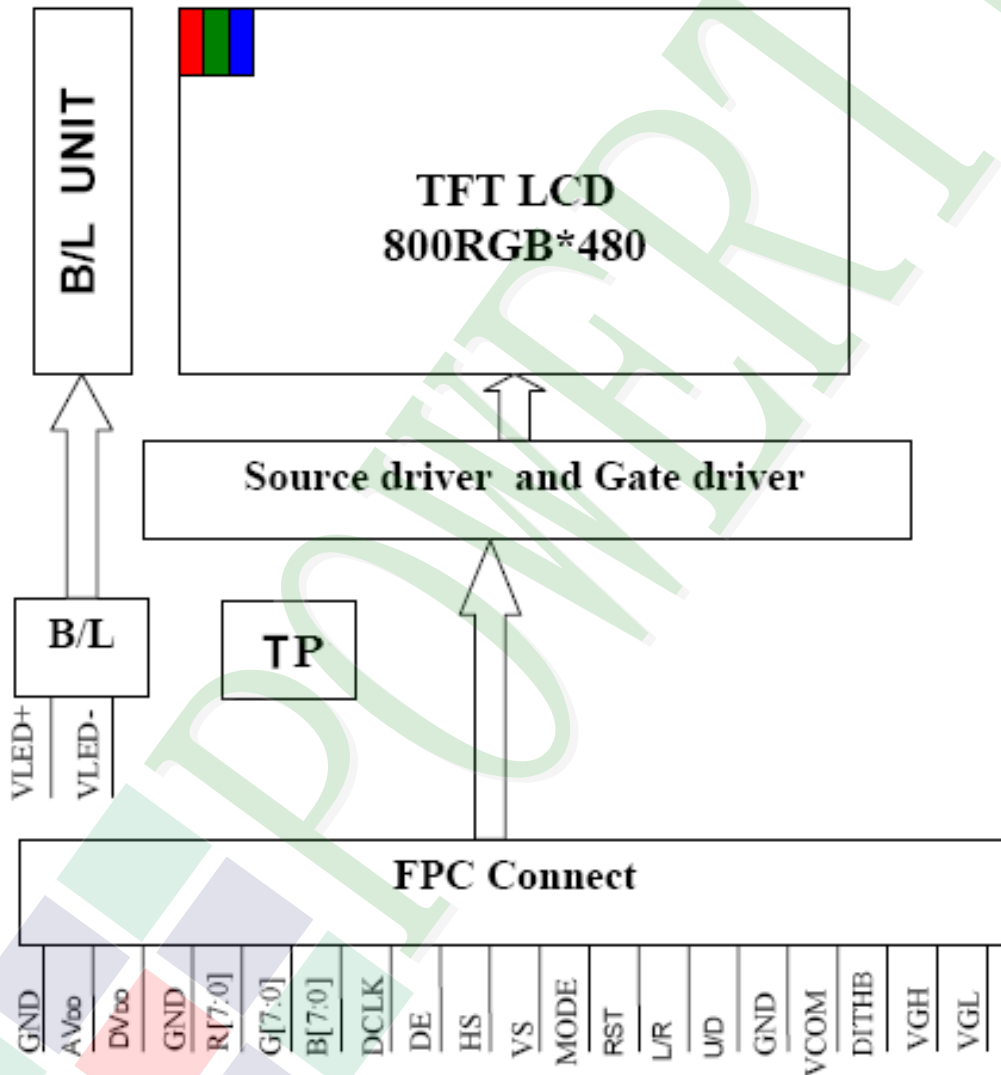

2.2 Interface Pin Description

Pin NO.	SYMBOL	DESCRIPTION	Type:Remark
1	V _{LED+}	Power For LED backlight (+).	Power
2	V _{LED+}	Power For LED backlight (+).	Power
3	V _{LED-}	Power For LED backlight (-).	Power
4	V _{LED-}	Power For LED backlight (-).	Power
5	GND	Power ground.	Power
6	V _{com}	Common voltage.	I
7	DV _{DD}	Power for Digital Circuit.	I
8	MODE	DE/SYNC mode select.	I,Note 1
9	DE	Data Input Enable.	I
10	VS	Vertical Sync Input.	I
11	HS	Horizontal Sync Input.	I
12	B7	Blue Data(MSB).	I
13	B6	Blue Data.	I
14	B5	Blue Data.	I
15	B4	Blue Data.	I
16	B3	Blue Data.	I
17	B2	Blue Data.	I
18	B1	Blue Data.	I:Note 2
19	B0	Blue Data(LSB).	I:Note 2
20	G7	Green Data(MSB).	I
21	G6	Green Data.	I
22	G5	Green Data.	I
23	G4	Green Data.	I
24	G3	Green Data.	I
25	G2	Green Data.	I
26	G1	Green Data.	I:Note 2
27	G0	Green Data(LSB).	I:Note 2
28	R7	Red Data(MSB).	I
29	R6	Red Data.	I
30	R5	Red Data.	I
31	R4	Red Data.	I
32	R3	Red Data.	I
33	R2	Red Data.	I
34	R1	Red Data.	I:Note 2
35	R0	Red Data(LSB).	I:Note 2
36	GND	Power Ground	Power
37	DCLK	Sample clock	I:Note 3

Pin NO.	SYMBOL	DESCRIPTION	Type:Remark
38	GND	Power Ground.	Power
39	L/R	Left / right selection.	I:Note 4,5
40	U/D	Left / right selection.	I:Note 4,5
41	V _{GH}	Gate On Voltage.	Power
42	V _{GL}	Gate OFF Voltage.	Power
43	AV _{DD}	Power for Analog Circuit.	Power
44	RESET	Global reset pin.	I:Note 6
45	NC	No connection.	-
46	V _{COM}	Common Voltage.	I
47	DITHB	Dithering Function.	I:Note 7
48	GND	Power Ground.	Power
49	NC	No connection.	-
50	NC	No connection.	-

I:input

Note 1: DE/SYNC mode select. Normally pull high.

When select DE mode, MODE="1", VS and HS must pull high.

When select SYNC mode, MODE= "0", DE must be grounded.

Note 2: When input 18 bits RGB data, the two low bits of R,G and B data must be grounded.

Note 3: Data shall be latched at the falling edge of DCLK.

Note 4: Selection of scanning mode.

Setting of scan control input		Scanning direction
U/D	L/R	
GND	DV _{DD}	Up to down, left to right
DV _{DD}	GND	Down to up, right to left
GND	GND	Up to down, right to left
DV _{DD}	DV _{DD}	Down to up, left to right

Note 5: Definition of scanning direction.

Refer to the figure as below:

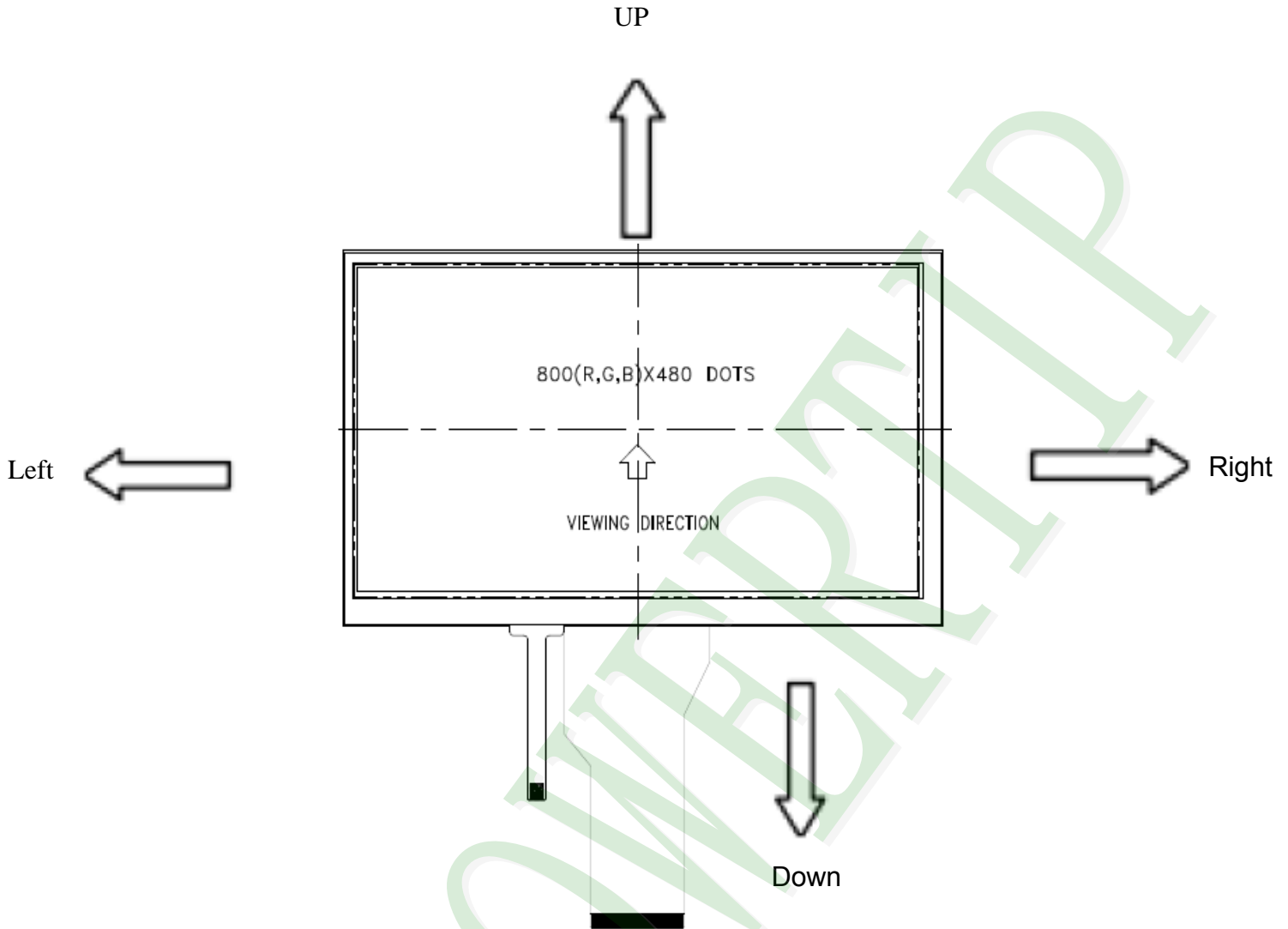

Note 6: Global reset pin. Active low to enter reset state. Suggest to connect with an RC reset circuit for stability. Normally pull high.

Note 7: Dithering function enable control, normally pull high.
 When DITHB="1", Disable internal dithering function.
 When DITHB="0", Enable internal dithering function.

Touch Panel Pin Description

Pin No.	Symbol	Function
1	X+	RIGHT.(XR)
2	Y-	BOTTOM.(YB)
3	X-	LEFT.(XL)
4	Y+	TOP.(YT)

2.3 Timing Characteristics

2.3.1 Signal AC Characteristics

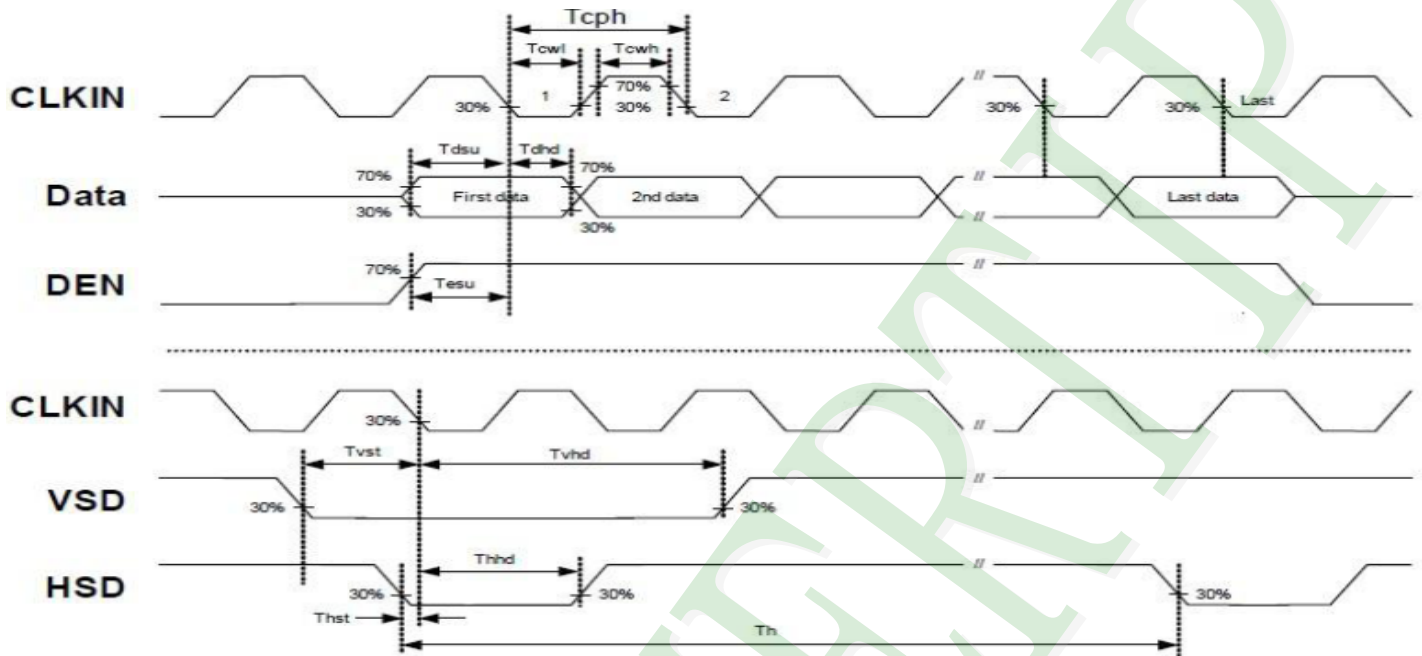

Item	Symbol	Values			Unit	Remark
		Min	Typ	Max.		
HS setup time	T_{hst}	8	-	-	ns	
HS hold time	T_{hhd}	8	-	-	ns	
VS setup time	T_{vst}	8	-	-	ns	
VS setup time	T_{vhd}	8	-	-	ns	
VS setup time	T_{dsu}	8	-	-	ns	
VS setup time	T_{dhd}	8	-	-	ns	
DE setup time	T_{esu}	8	-	-	ns	
DE hole time	T_{ehd}	8	-	-	ns	
DV _{DD} Power On Slew rate	T_{POR}	-	-	20	ms	From 0 to 90% DV _{DD}
RESET pulse width	T_{Rst}	1	-	-	ms	
DCLK cycle time	T_{coh}	20	-	-	ns	
DCLK pulse duty	T_{cwh}	40	50	60	%	

2.3.2 Input Timing Setting

Item	Symbol	Values			Unit	Remark
		Min.	Typ.	Max.		
Horizontal Display Area	Thd		800		DCLK	
DCLK Frequency	Fclk	26.4	33.3	46.8	MHz	
One Horizontal Line	Th	862	1056	1200	DCLK	
HS pulse width	Thpw	1		40	DCLK	
HS Blanking	Thb	46	46	46	DCLK	
HS Front Porch	Thfp	16	210	354	DCLK	

Item	Symbol	Values			Unit	Remark
		Min.	Typ.	Max.		
Vertical Display Area	Tvd		480		TH	
VS period time	Tv	510	525	650	TH	
VS pulse width	Tvpw	1		20	TH	
VS Blanking	Tvb	23	23	23	TH	
VS Front Porch	Tvfp	7	22	147	TH	

Horizontal input timing diagram

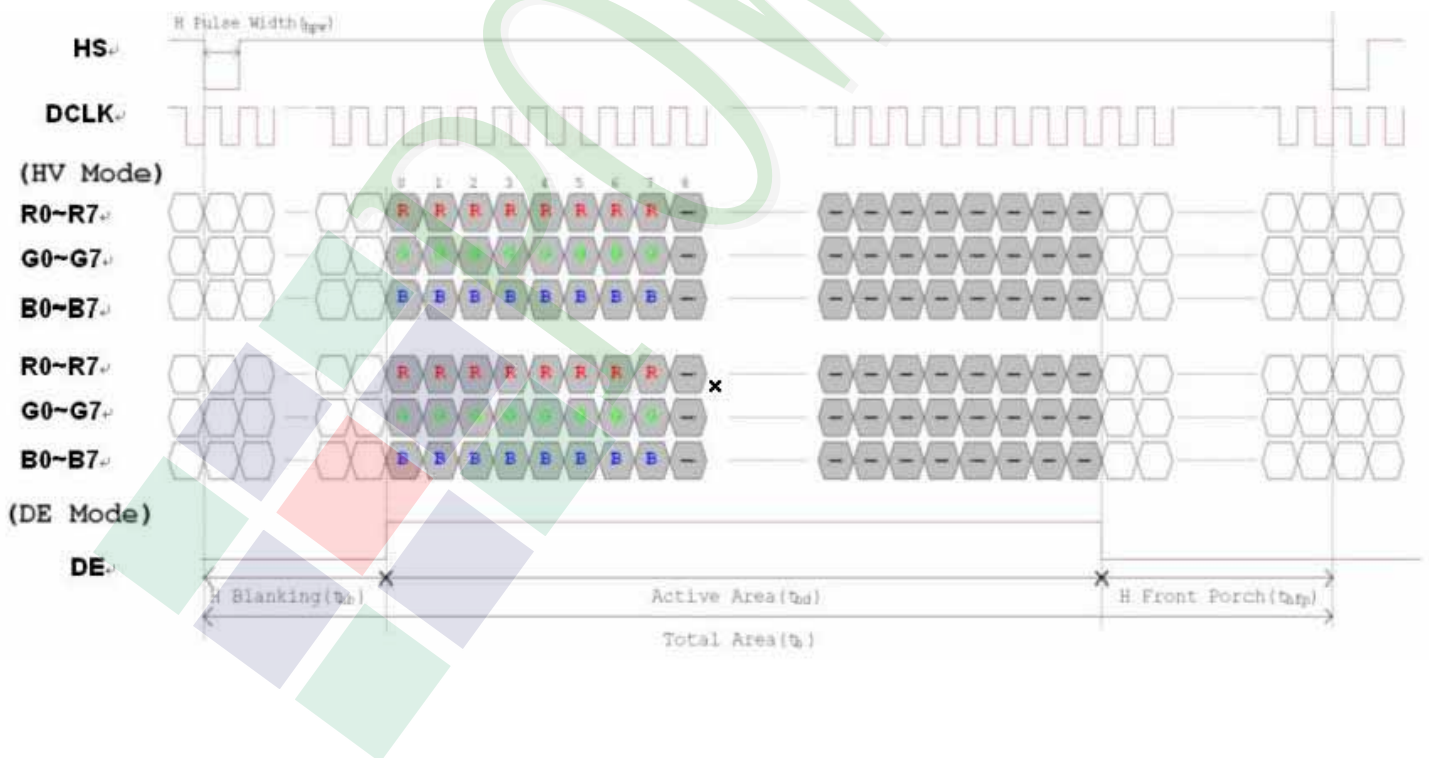



Vertical input timing diagram

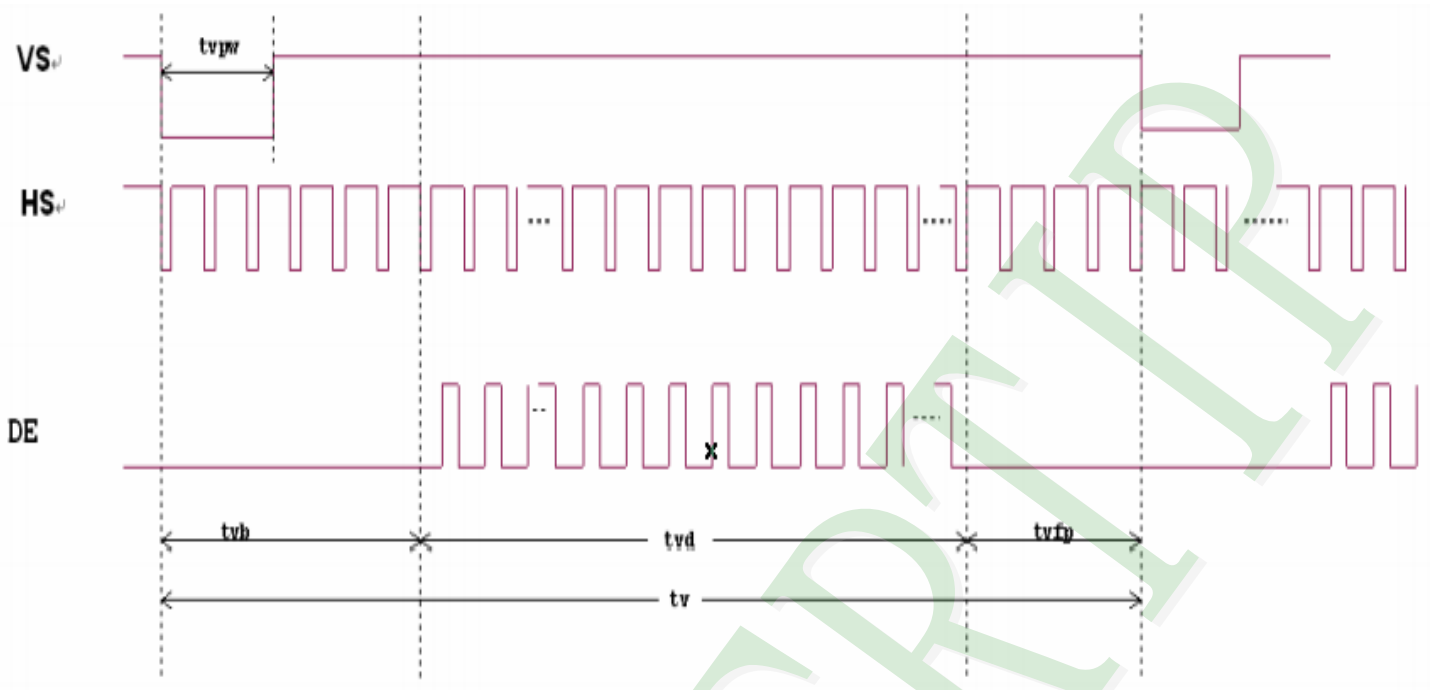

2.3.3 Power On/Off Characteristics

a. Power on:

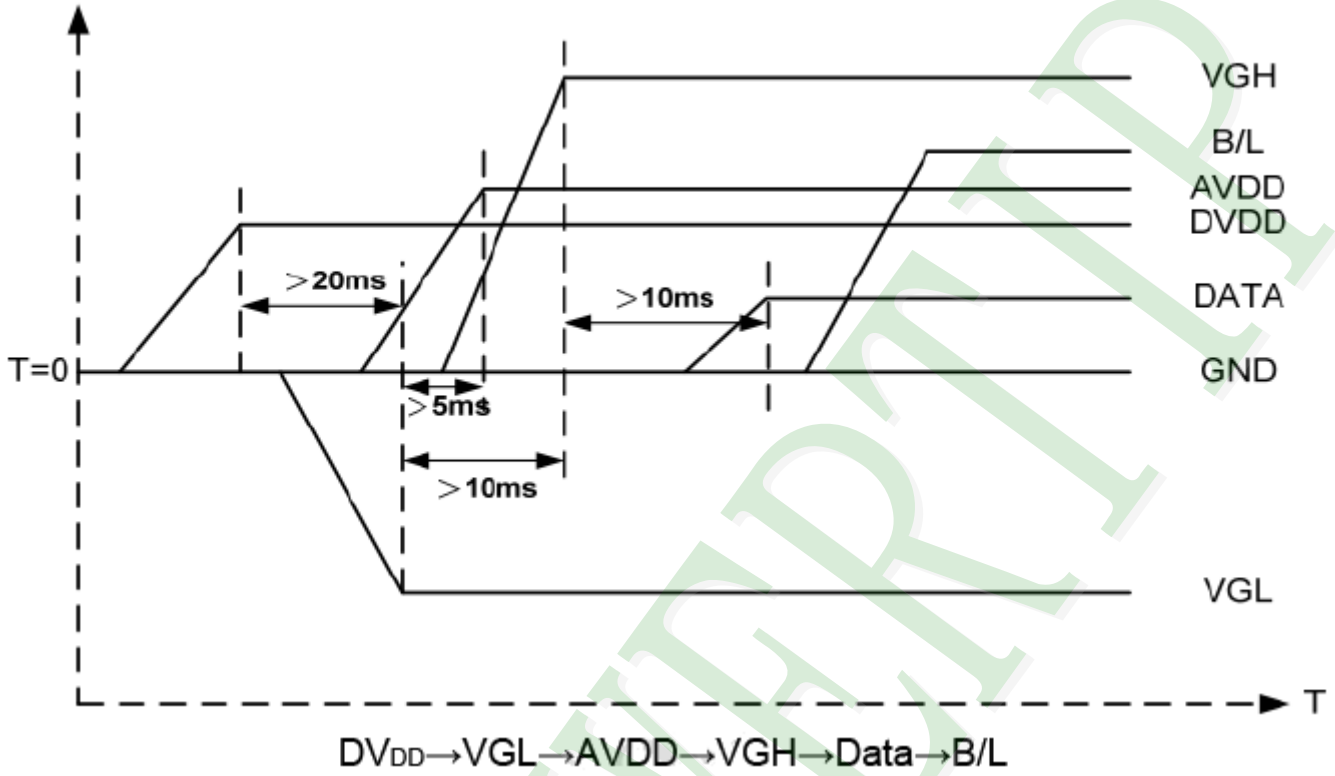

b. Power off:

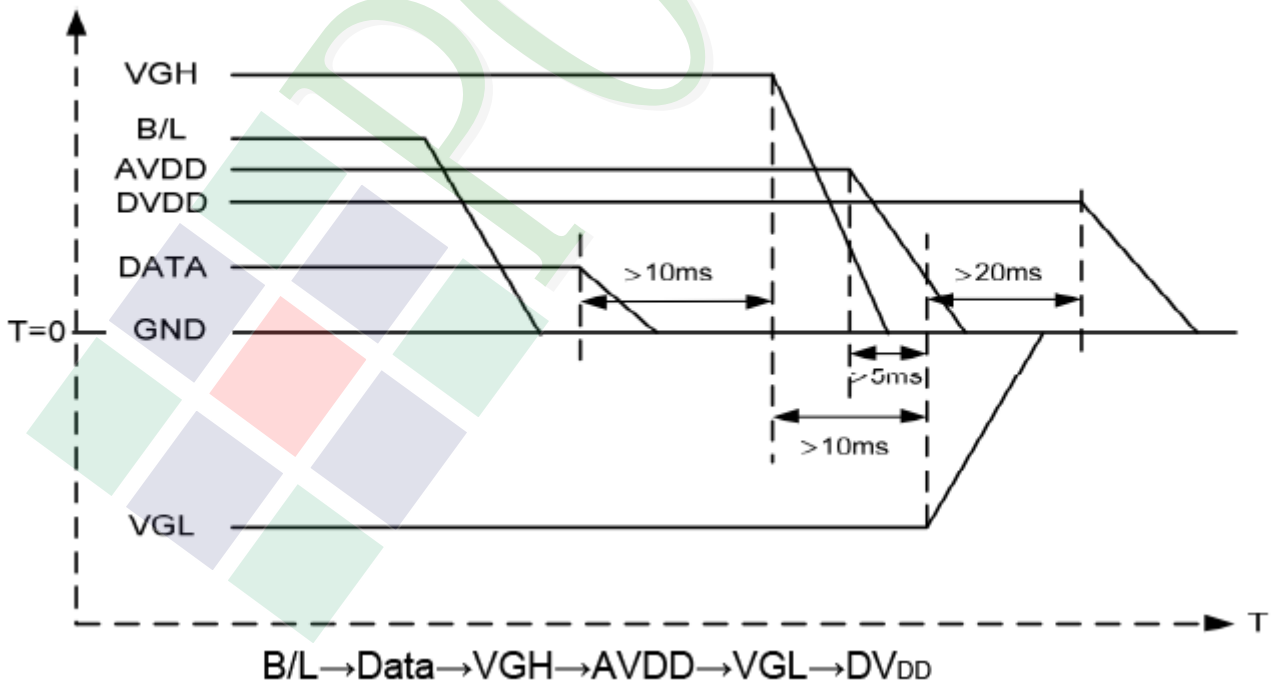

3. QUALITY ASSURANCE SYSTEM

3.1 Quality Assurance Flow Chart

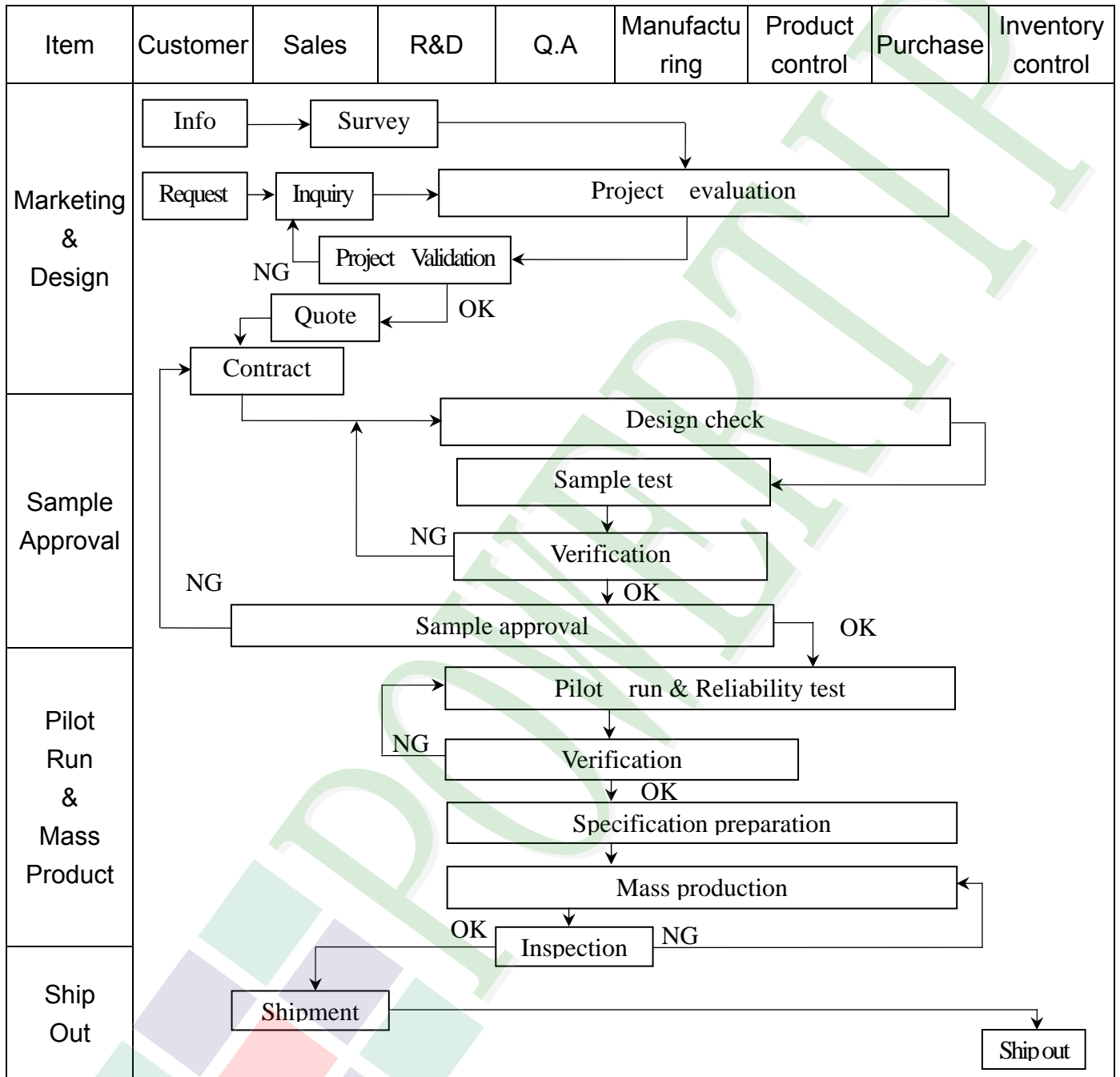

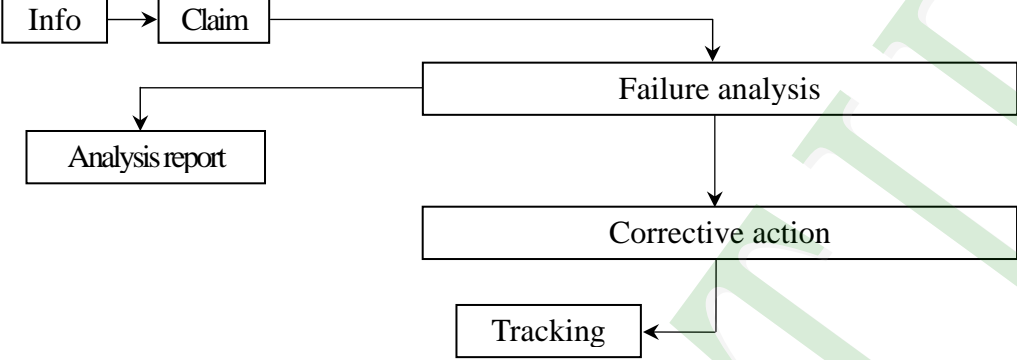
Item	Customer	Sales	R&D	Q.A	Manufacturing	Product control	Purchase	Inventory control
Sales Service	 <pre> graph TD Info[Info] --> Claim[Claim] Claim --> Failure[Failure analysis] Claim --> Report[Analysis report] Failure --> Action[Corrective action] Action --> Tracking[Tracking] </pre>							
Q.A Activity	1. ISO 9001 Maintenance Activities 3. Equipment calibration 5. Standardization Management				2. Process improvement proposal 4. Education And Training Activities			

3.2. Inspection Specification

Scope : The document shall be applied to PH800480T-013-I01Q(Ver.01).

The customer should check and accept the products of linjia within one month after reception. This standard for Quality Assurance should affirm the quality of LCD products to supply to purchaser by Solon company Limited.

1.1.1 Appearance Inspection

Appearance inspection should be done under the following condition.

- (1) In the dark room.
- (2) The distance from eyes to LCD must be 30 cm.
- (3) Viewing direction must be within 30 degrees to vertical line of LCD center.

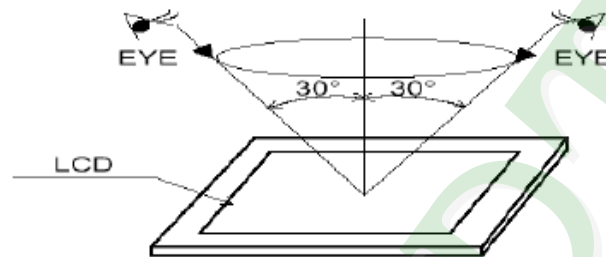

1.1.2 Definition of A zone, B zone and C zone

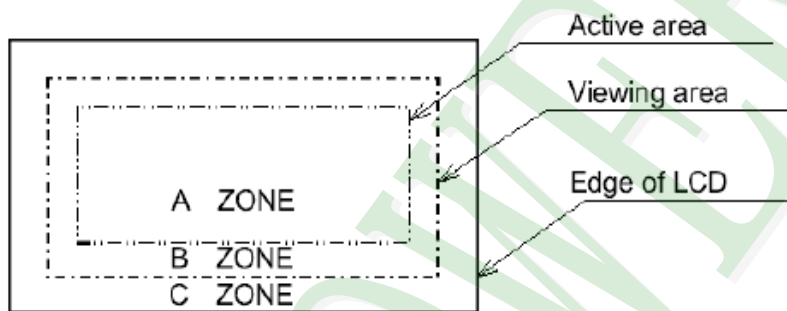

1.1.3 Appearance Criterion

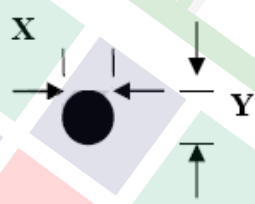
Item	Criterion	Note																			
LCD black spots, white spots, color spots, contamination, scratches (display/non-display)	1. Round type: As following drawing $\phi = (x+y)/2$ 																				
	<table border="1"> <thead> <tr> <th rowspan="2">Size</th> <th colspan="2">Acceptable QTY</th> <th rowspan="2">Remark</th> </tr> <tr> <th>A.A</th> <th>V.A</th> </tr> </thead> <tbody> <tr> <td>$\phi \leq 0.2$</td> <td>Ignore</td> <td>Ignore</td> <td rowspan="4">No more than two spots within 5mm</td> </tr> <tr> <td>$0.2 < \phi \leq 0.4$</td> <td>1</td> <td>4</td> </tr> <tr> <td>$0.4 < \phi$</td> <td>0</td> <td>0</td> </tr> <tr> <td>Total</td> <td>1</td> <td>4</td> </tr> </tbody> </table>	Size	Acceptable QTY		Remark	A.A	V.A	$\phi \leq 0.2$	Ignore	Ignore	No more than two spots within 5mm	$0.2 < \phi \leq 0.4$	1	4	$0.4 < \phi$	0	0	Total	1	4	
	Size		Acceptable QTY			Remark															
		A.A	V.A																		
	$\phi \leq 0.2$	Ignore	Ignore	No more than two spots within 5mm																	
$0.2 < \phi \leq 0.4$	1	4																			
$0.4 < \phi$	0	0																			
Total	1	4																			

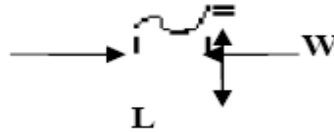
2. Line Type: (As following drawing)



Length	Width	Acceptable QTY		Remark
		A.A	V.A	
---	$W \leq 0.03$	Ignore	Ignore	
$L \leq 2.5$	$0.03 < W \leq 0.05$	2	4	No more than two lines within 5mm
$L \leq 1.5$	$0.05 < W \leq 0.08$			
---	$0.08 < W$	0	0	

3. Scratch:

Length	Width	Acceptable number	Mini space
$L \leq 1.5$	$0.02 \leq W \leq 0.05$	Ignore	10mm
$1.5 < L \leq 2.5$	$0.02 \leq W \leq 0.05$	3	
$2.5 < L \leq 3.5$	$0.02 \leq W \leq 0.05$	2	
$2.5 \leq L \leq 3.5$	$0.05 \leq W \leq 0.1$	Not allowed	
$L > 3.5$	$W > 0.1$	Not allowed	

4. Function:

No display or No function not allowed.
Missing vertical, horizontal segment not allowed.
Segment Contrast defect not allowed.
Viewing angle defect not allowed.
Current consumption exceeds product specifications not allowed.
Display malfunction not allowed.
Pervious to light be not allowed.
Picture had shake, twinkle and noise etc. instable of defect that be not allowed.

	<p>Cross stalk not allowed. Image persistence not allowed. BM light leakage not allowed.</p> <p>5. Sub pixel classification</p> <p>Sub Pixel: a> Bright dot <= 1Dot, Dark dot <= 2Dot, Total <= 3Dot b> Two or more dots link together doesn't be allowed</p> <div style="text-align: center;">  <p>Sub Pixel (Dot)</p> </div> <p>Pixel : Three dots link together doesn't allowed</p> <div style="text-align: center;">  <p>Pixel</p> </div>												
Polarizer bubbles	<p>If bubbles are visible, judge using black spot specifications, not easy to find, must check in specify direction.</p> <table border="1" style="margin-left: auto; margin-right: auto;"> <thead> <tr> <th rowspan="2">Size</th> <th colspan="2">Acceptable QTY</th> </tr> <tr> <th>A.A</th> <th>V.A</th> </tr> </thead> <tbody> <tr> <td>$\phi \leq 0.3$</td> <td>Ignore</td> <td>Ignore</td> </tr> <tr> <td>$0.3 < \phi \leq 0.6$</td> <td>3</td> <td>4</td> </tr> </tbody> </table>	Size	Acceptable QTY		A.A	V.A	$\phi \leq 0.3$	Ignore	Ignore	$0.3 < \phi \leq 0.6$	3	4	
Size	Acceptable QTY												
	A.A	V.A											
$\phi \leq 0.3$	Ignore	Ignore											
$0.3 < \phi \leq 0.6$	3	4											
Chipped glass	<p>Symbols: a: Chip length b: Chip width c: Chip thickness t: Glass thickness</p> <p>1 ITO electrode</p>												

◆ Specification For PH800480T-013-I01Q :

(Ver.01)

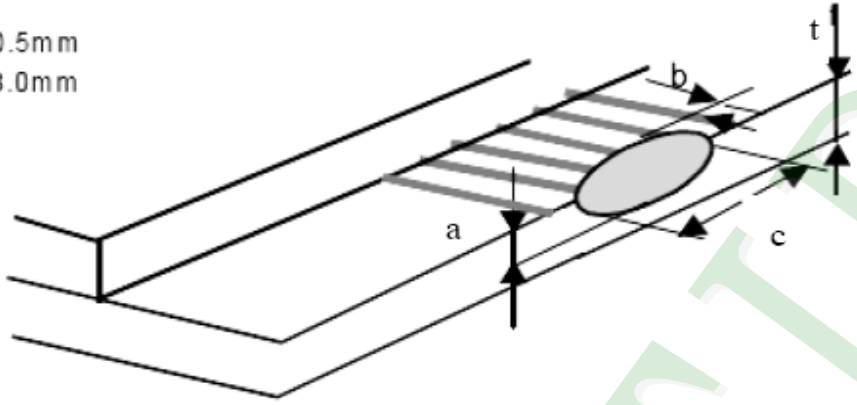
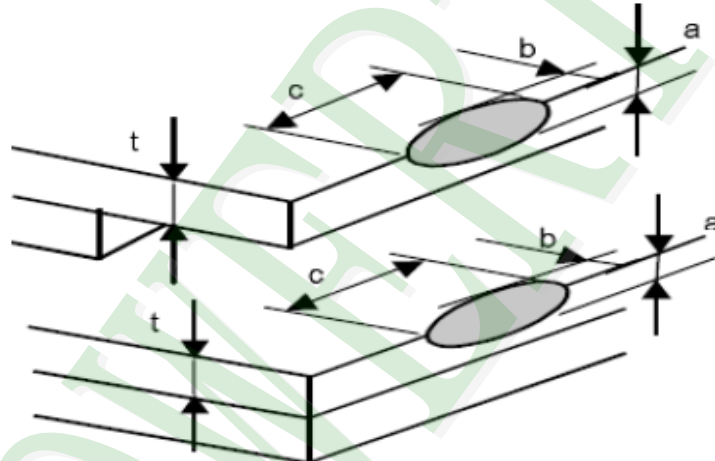
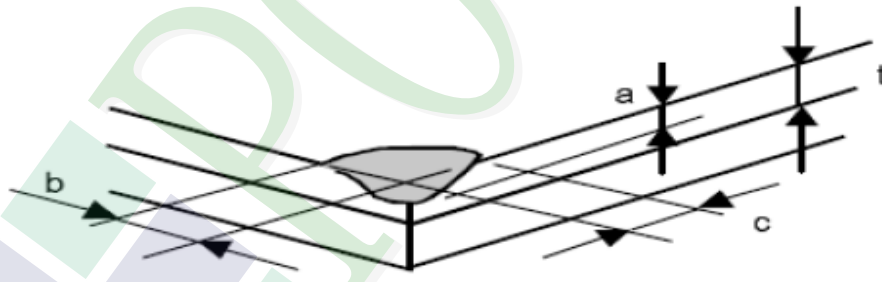
	<p> $a \leq t$ $b \leq 0.5\text{mm}$ $c \leq 3.0\text{mm}$ </p>  <p> 2 General ,corner portion </p> <p> $a \leq t$ $b \leq 1.0\text{mm}$ $c \leq 3.0\text{mm}$ </p>  <p> *Effective width of seal area shall be more than 0.3mm. </p> 	
Cracked glass	The LCD with extensive crack is not acceptable.	
Mura	It's OK if mura is not visible through 6%ND filter. (Judged by limit sample if it is necessary)	
Functional failure	(V-line/H-line/Cross line etc.) Not allowable	
Panel scratch of A arer	Not allow under transmission light inspection.	

◆ Specification For PH800480T-013-I01Q :

(Ver.01)

Backlight elements	<ol style="list-style-type: none"> 1 Illumination source flickers when lit. 2 Spots or scratches that appear when lit must be judged using LCD spot, lines and contamination standards. 3 Backlight doesn't light or color is wrong. 4 No bezel with rusty spot. 5 No bezel deformed. 6 No greasiness. 7 No bezel with bump. 8 No bezel with scratch. 9 No poor electroplating. 	
Soldering & FPC	<ol style="list-style-type: none"> 1 No unmelted solder paste may be present on the PCB. 2 No cold solder joints, missing solder connections, oxidation or icicle. 3 No residue or solder balls on PCB. 4 No short circuits in components on PCB. 5 No copper floated. 6 No release paper missing or stripping. 7 No Gold finger smudginess. 8 No ground pad smudginess. 9 No ground pad scratch. 10 No ground pad with dark spot. 	
General appearance	<ol style="list-style-type: none"> 1 No oxidation, contamination, curves or, bends on interface pin (OLB) of TCP. 2 No cracks on interface pin(OLB) of TCP 3 NO contamination, solder residue or solder balls on product. 4 The IC on the TCP may not be damaged, circuits. 5 The residual rosin or tin oil of soldering (component or chip component) is not burned into brown or black color. 6 Sealant on top of the ITO circuit has not hardened 7 Pin type must match type in specification sheet. 8 No LCD pin loose or missing pins. 9 No release paper stripped from PLZ 10 LCD discolored not allowed. 11 No conducting layer smudginess. 12 Panel surface smudged not allowed. 13 Polarizer skewing, smudginess and bad edge not allowed. 14 Product packaging must the same as specified on packaging specification sheet. 15 Product dimension and structure must conform to product specification sheet. 16 Reject ratio no more than 3000 PPM. 17 AQL: GB/T2828.1-2003 LEVEL 2 MAJ. =0.4 ,MIN. = 0.65 18 MTBF 20K hrs 	

4. RELIABILITY TEST

4.1 Reliability Test Condition

(Ver.B01)

NO.	TEST ITEM	TEST CONDITION										
1	High Temperature Storage Test	Keep in +80 ±2°C 96 hrs Surrounding temperature, then storage at normal condition 4hrs.										
2	Low Temperature Storage Test	Keep in -30 ±2°C 96 hrs Surrounding temperature, then storage at normal condition 4hrs.										
3	High Temperature / High Humidity Storage Test	Keep in +60°C / 90% R.H duration for 96 hrs Surrounding temperature, then storage at normal condition 4hrs. (Excluding the polarizer)										
4	Temperature Cycling Storage Test	<p style="text-align: center;"> $-30^{\circ}\text{C} \rightarrow +25^{\circ}\text{C} \rightarrow +80^{\circ}\text{C} \rightarrow +25^{\circ}\text{C}$ (30mins) (5mins) (30mins) (5mins) \longleftrightarrow 10 Cycle </p> <p>Surrounding temperature, then storage at normal condition 4hrs.</p>										
5	ESD Test	Air Discharge: Apply 2 KV with 5 times Discharge for each polarity +/-										
		Contact Discharge: Apply 250 V with 5 times discharge for each polarity +/-										
6	Vibration Test (Packaged)	<ol style="list-style-type: none"> Sine wave 10 ~ 55 Hz frequency (1 min) The amplitude of vibration : 1.5 mm Each direction (X、Y、Z) duration for 2 Hrs 										
7	Drop Test (Packaged)	<table border="1" style="margin-left: auto; margin-right: auto;"> <thead> <tr> <th>Packing Weight (Kg)</th> <th>Drop Height (cm)</th> </tr> </thead> <tbody> <tr> <td>0 ~ 45.4</td> <td>122</td> </tr> <tr> <td>45.4 ~ 90.8</td> <td>76</td> </tr> <tr> <td>90.8 ~ 454</td> <td>61</td> </tr> <tr> <td>Over 454</td> <td>46</td> </tr> </tbody> </table> <p style="text-align: center;">Drop direction : ※1 corner / 3 edges / 6 sides each 1times</p>	Packing Weight (Kg)	Drop Height (cm)	0 ~ 45.4	122	45.4 ~ 90.8	76	90.8 ~ 454	61	Over 454	46
Packing Weight (Kg)	Drop Height (cm)											
0 ~ 45.4	122											
45.4 ~ 90.8	76											
90.8 ~ 454	61											
Over 454	46											

5. PRECAUTION RELATING PRODUCT HANDLING

5.1 SAFETY

- 5.1.1 If the LCD panel breaks , be careful not to get the liquid crystal to touch your skin.
- 5.1.2 If the liquid crystal touches your skin or clothes , please wash it off immediately by using soap and water.

5.2 HANDLING

- 5.2.1 Avoid any strong mechanical shock which can break the glass.
- 5.2.2 Avoid static electricity which can damage the CMOS LSI—When working with the module , be sure to ground your body and any electrical equipment you may be using.
- 5.2.3 Do not remove the panel or frame from the module.
- 5.2.4 The polarizing plate of the display is very fragile. So , please handle it very carefully ,do not touch , push or rub the exposed polarizing with anything harder than an HB pencil lead (glass , tweezers , etc.)
- 5.2.5 Do not wipe the polarizing plate with a dry cloth , as it may easily scratch the surface of plate.
- 5.2.6 Do not touch the display area with bare hands , this will stain the display area.
- 5.2.7 Do not use ketonics solvent & aromatic solvent. Use with a soft cloth soaked with a cleaning naphtha solvent.
- 5.2.8 To control temperature and time of soldering is $320\pm 10^{\circ}\text{C}$ and 3-5 sec.
- 5.2.9 To avoid liquid (include organic solvent) stained on LCM .

5.3 STORAGE

- 5.3.1 Store the panel or module in a dark place where the temperature is $25^{\circ}\text{C} \pm 5^{\circ}\text{C}$ and the humidity is below 65% RH.
- 5.3.2 Do not place the module near organics solvents or corrosive gases.
- 5.3.3 Do not crush , shake , or jolt the module.

5.4 TERMS OF WARRANTY

- 5.4.1 Applicable warrant period
The period is within thirteen months since the date of shipping out under normal using and storage conditions.
- 5.4.2 Unaccepted responsibility
This product has been manufactured to your company's specification as a part for use in your company's general electronic products. It is guaranteed to perform according to delivery specifications. For any other use apart from general electronic equipment , we cannot take responsibility if the product is used in nuclear power control equipment , aerospace equipment , fire and security systems or any other applications in which there is a direct risk to human life and where extremely high levels of reliability are required.

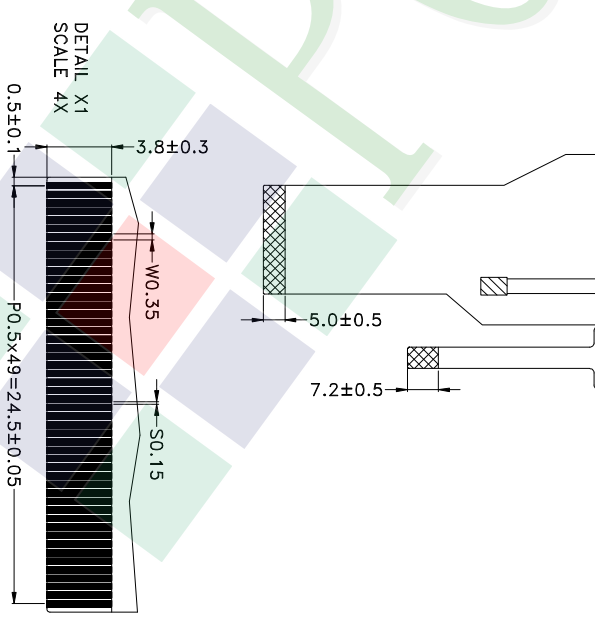
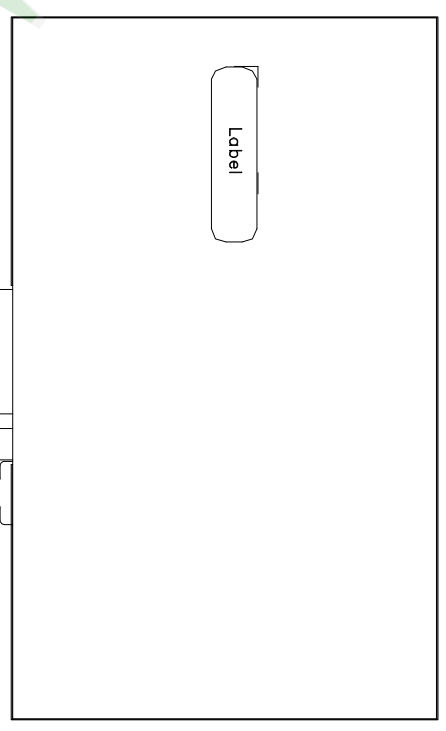
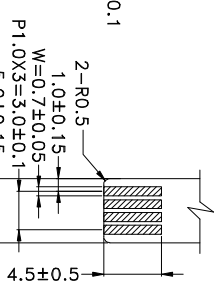
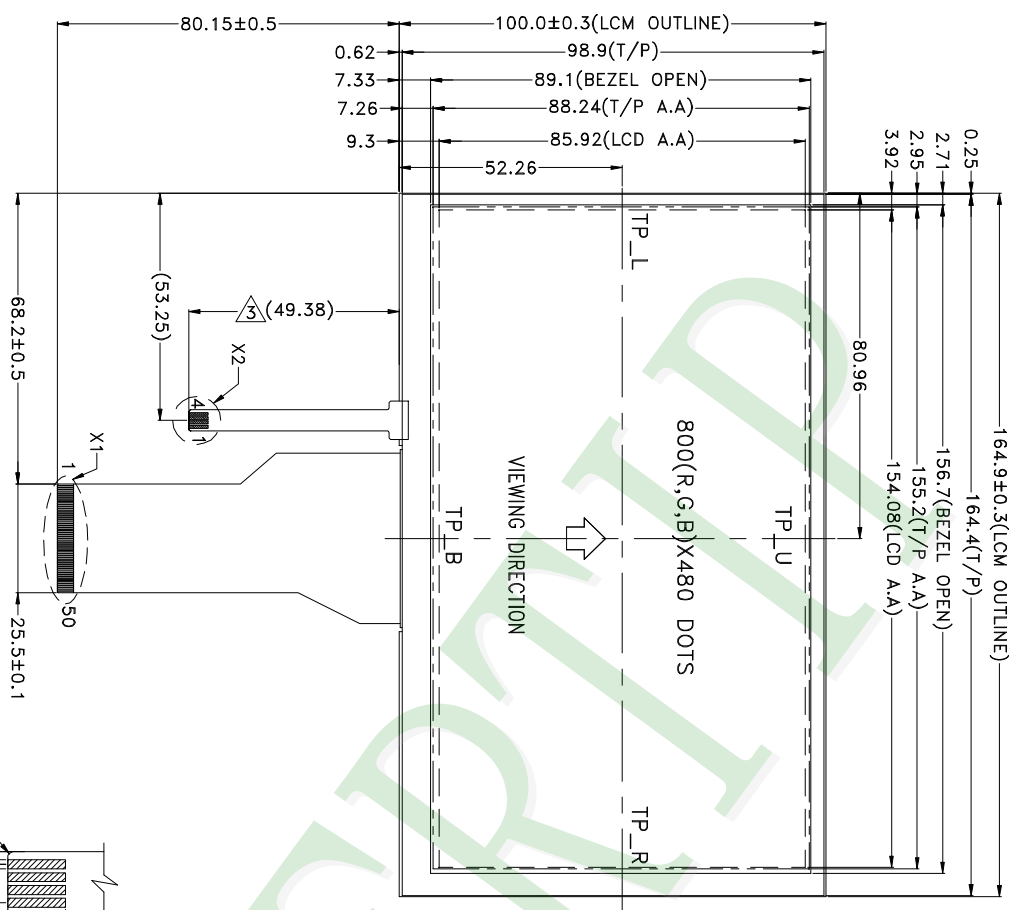

- NOTES:
- 1.LCD TYPE: TFT LCD
 - 2.LCD DISPLAY: POSITIVE/TRANSMISSIVE
 - 3.VIEW DIRECTION: 6 O'CLOCK
 - 4.The tolerance unless classified $\pm 0.2\text{mm}$
 - 5.LCM FPC Matching Connector : HIROSE FH12A-50S-0.5H OR EQUIVALENT

007				PART NO:	PH800480T-013-101Q	 久正光電股份有限公司 POWER TIP TECHNOLOGY CORPORATION	Design	Stone	Unit MM Scale 1:1 Page 1/1	Surface		Tolerance Length (mm) (Min) Precision Level
006				DRAWING NAME:	LMD-PH800480T-013-101Q		Check	Sam		Material		
005				TITLE:	LCD MODULE DRAWING	Approve	Oliver	Thickness				
004								Quantity				
003	MODIFY TOUCH PANEL FPC LENGTH	Stone	2013/01/23									
002	MODIFY TOUCH PANEL DIMENSION	Stone	2012/12/07									
001	NEW DRAWING	Stone	2012/09/06									
REV	REV BY	REVISED	DATE									

Approve	Check	Contact
Oliver	Sam	Stone

Documents NO. PKG-PH800480T-013-I01Q

1. 包裝材料規格表 (Packaging Material) : (per carton)

No.	Item	Model	Dimensions (mm)	1Pcs Weight	Quantity	Total Weight
1	成品 (LCM)	PH800480T-013-I01Q	164.9 X 100.0	0.16	60	9.6
2	靜電袋(1)Antistatic Bag	BAG240170ARABA	240 X 170	0.0048	60	0.288
3	上蓋(2)EPE	FOAM000000078	310 X 250 X 90	0.1	4	0.4
4	下座(3)EPE	FOAM000000079	310 X 250 X 100	0.17	4	0.68
5	海綿墊(4)Foam Rubber Cushion	OTFOAM00006ABA	290 X 240 X 10	0.0058	8	0.0464
6	外紙箱(5)Carton	BX52732536CCBA	527 X 325 X 360	1.092	1	1.092
7						
8						
9						

2. 一整箱總重量 (Total LCD Weight in carton) : 12.11 Kg±10%

3. 單箱數量規格表 (Packaging Specifications and Quantity) :

(1) Total LCD quantity in carton : quantity per box 15 x no of boxes 4 = 60

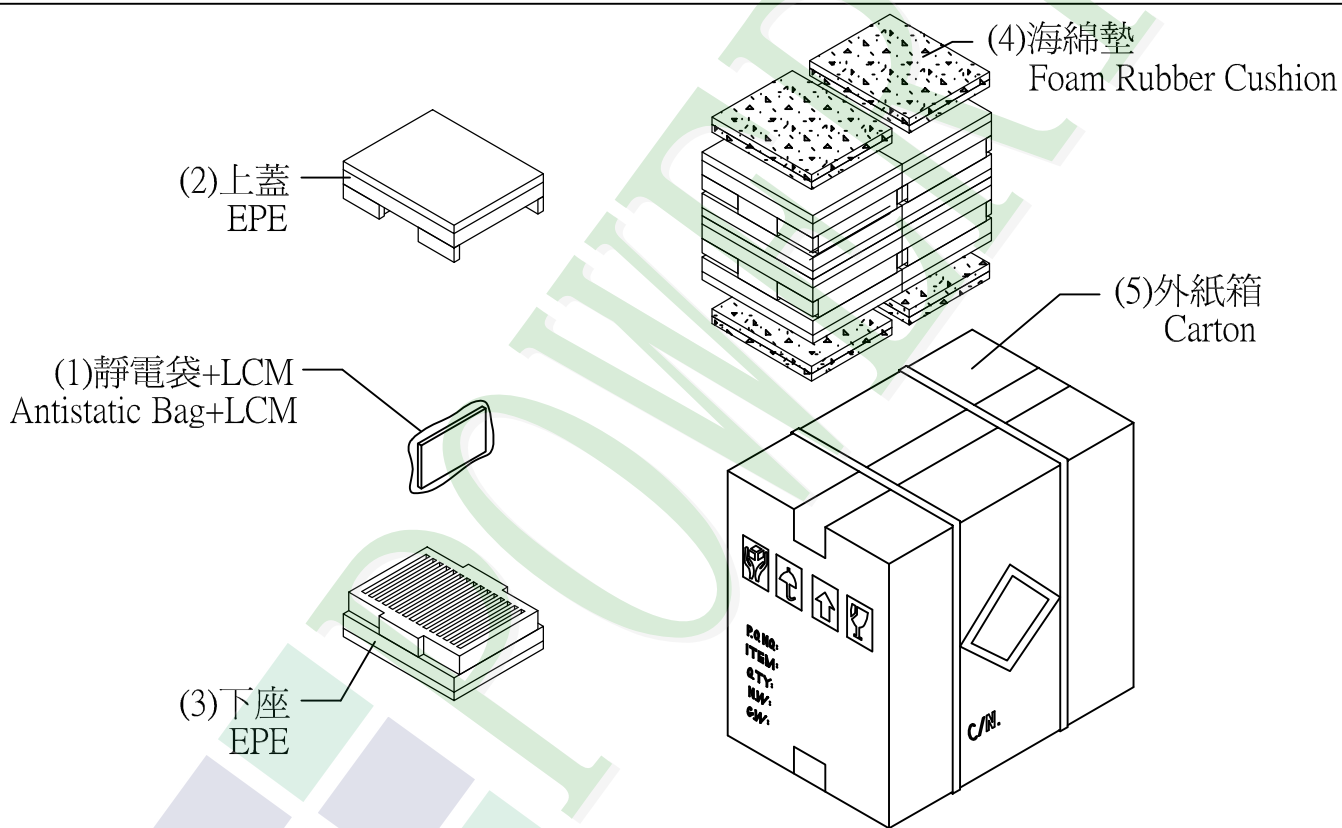

特記事項 (REMARK)

4. Label Specifications :

TYPE			
ID.NO	S/O		
Q'TY	Pcs	Date	
Lot.NO			
Note			

參照"成品包裝點檢作業標準書"內容

5. 包裝數量不足時需以EPE(舒美墊)填補空槽

EPE:OTFOAMEP0003BA自裁成
(166.5X109.0X10mm)