



# polyfet rf devices

## PHM020

### Power RF Amplifiers

Power = 5.0 Watts

Bandwidth = 225 to 400 Mhz

Gain = 25.0 dB Vdd = 28.0 Volts

50 ohms Input/Output Impedance

### Description

The PHM020 is a 5 Watt FM / 1 Watt AM amplifier module covering a bandwidth of 225-400 Mhz. It has a high harmonic rating when operated in the AM mode. This dual stage amplifier is specifically designed for broad band portable radio applications. External Gate bias pin option is available upon request.

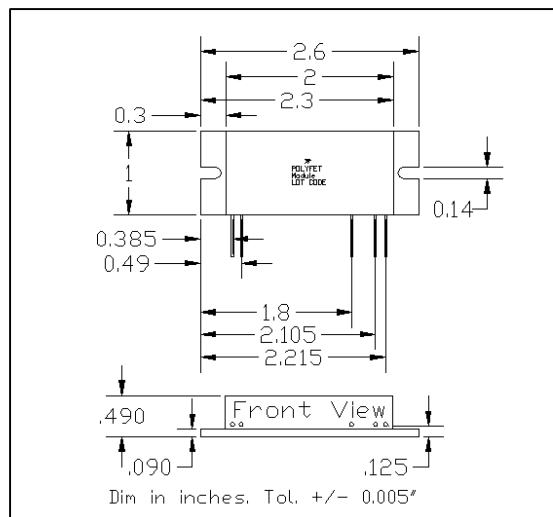

### Absolute Maximum Ratings (T=25 °C)

Parameter	Symbol	Value	Unit
DC supply Voltage 1	VDD1	32.0	V
DC supply Voltage 2	VDD2		V
AGC Voltage	VAGC		V
Input Power	Pin	0.02	W
Output Power	Pout	10.0	W
Operating Case Temp.	Tc	-20 to +85	°C
Storage Temperature	Tstg	-30 to +100	°C

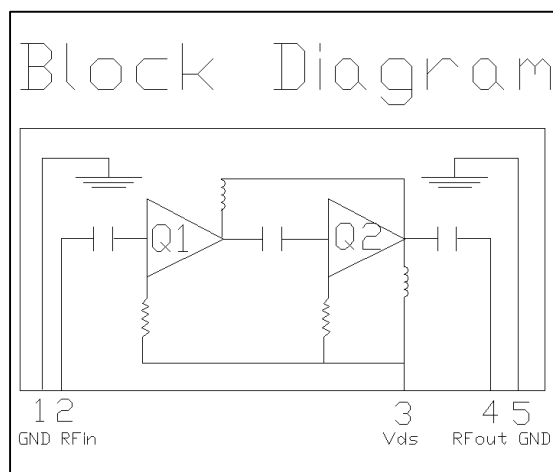

### Electrical Characteristics: ( T=25 °C Zs=Zl=50 ohms. Vdd= 28.0 Volts )

Parameter	Symbol	Min	Typical	Max	Unit	Test Conditions
Frequency Range	BW	225		400	Mhz	50 ohm load
Output Power	Po	5.0			Watts	Idq = 1.00 Amps
Power Gain	PG	25.0			dB	@ Pout = 5.0 Watts
Total Efficiency	h	13			%	@ Pout = 5.0 Watts
2nd Harmonics	dso		-30.00		dBc	@ Pout = 5.0 W, Freq = 312 Mhz
Intermod - 2 tone	Ip3				dBm	Freq = 312 Mhz; AvePwr= W
Load Mismatch Tolerance	VSWR	10:1			Relative	All Phase Angles

POLYFET RF DEVICES

REVISION 10/29/2005

1110 Avenida Acaso, Camarillo, Ca 93012 Tel:(805) 484-4210 FAX: (805) 484-3393 EMAIL:selling@polyfet.com URL:www.polyfet.com

www.DataSheet4U.com

# PHM020

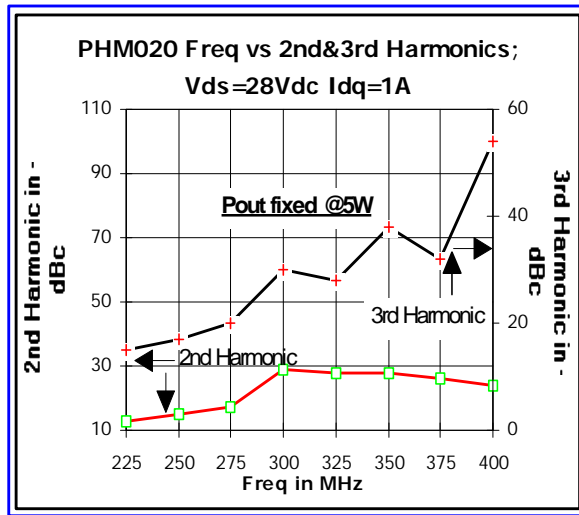
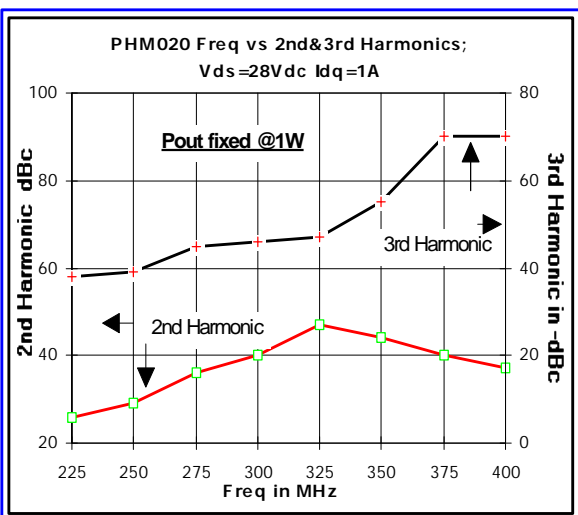
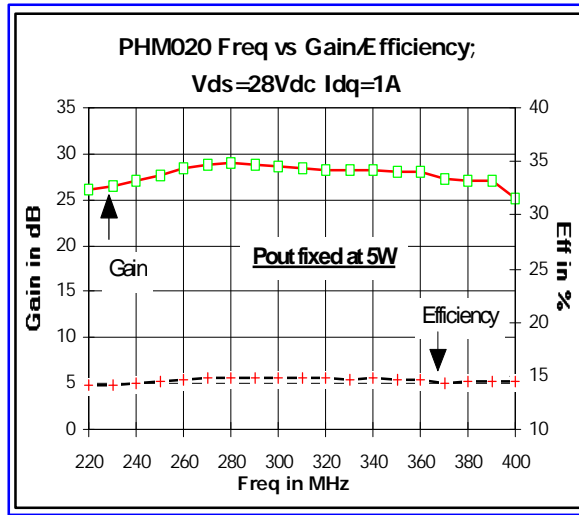
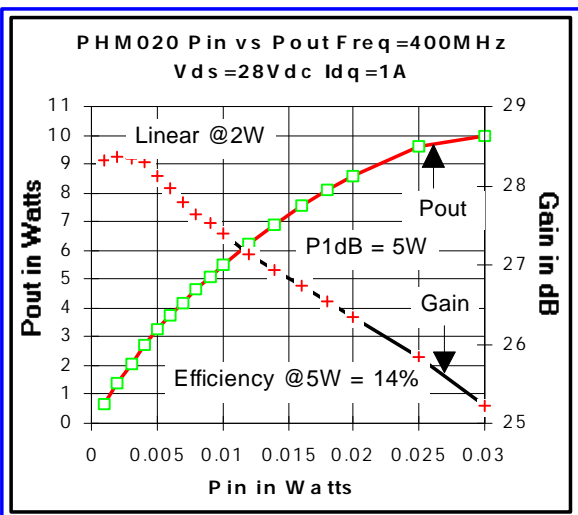
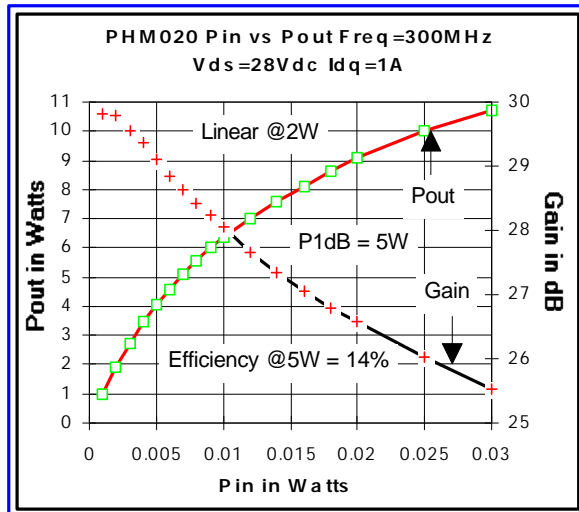
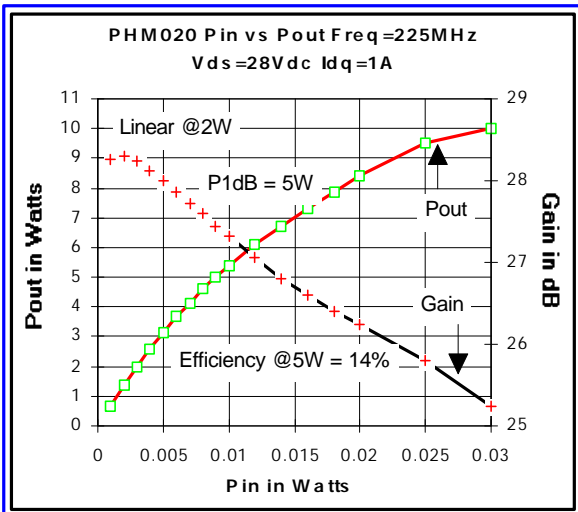

POLYFET RF DEVICES

REVISION 10/29/2005

1110 Avenida Acaso, Camarillo, Ca 93012 Tel:(805) 484-4210 FAX: (805) 484-3393 EMAIL:selling@polyfet.com URL:www.polyfet.com

www.DataSheet4U.com

www.DataSheet4U.com

www.DataSheet4U.com

www.DataSheet4U.com