

## 1.8V, PCI Express Compliant, 2 Differential Channel, 2:1 Mux/DeMux Switch w/ Single Enable

### Features

- 2 Differential Channel, 2:1 Mux/DeMux
- PCI Express signal compliance
- Low Bit-to-Bit Skew
- Low Crosstalk: -60dB@10MHz
- Low Off Isolation: -65dB@10MHz
- V<sub>CC</sub> Operating Range: +1.5V to +2.0V
- ESD Tolerance >2kV HBM
- Packaging (Pb-free & Green):
  - 28 contact TQFN (ZH)

### Description

Pericom Semiconductor's PI2PCIE212 is a 4 to 2 differential channel multiplexer/demultiplexer switch. The PI2PCIE family of switch solutions is fully compliant with PCI-express signals at 2.5Gbps. PI2PCIE212 can switch PCI-express signals up to a maximum length of 16 inches. Due to its low bit-to-bit skew, high channel-to-channel noise isolation and high bandwidth, this product is ideal for PCI Express switching.

### Application

Switch a PCI-Express lane output between two PCI-Express lane inputs

### Block Diagram

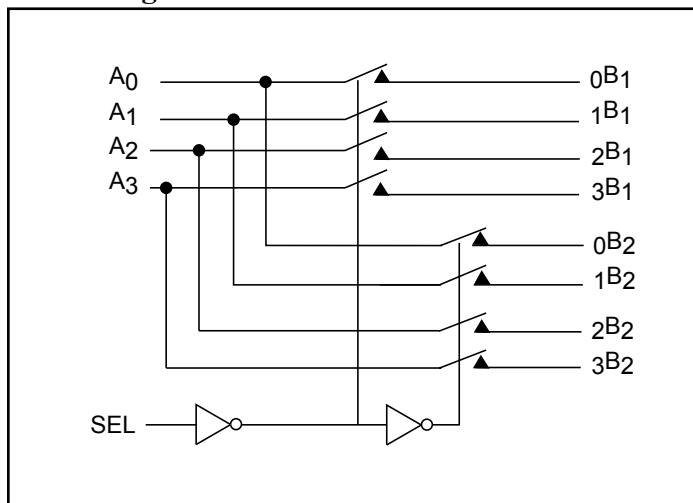

### Truth Table

Function	SEL
A <sub>n</sub> to <sub>n</sub> B <sub>1</sub>	L
A <sub>n</sub> to <sub>n</sub> B <sub>2</sub>	H

### Pin Description

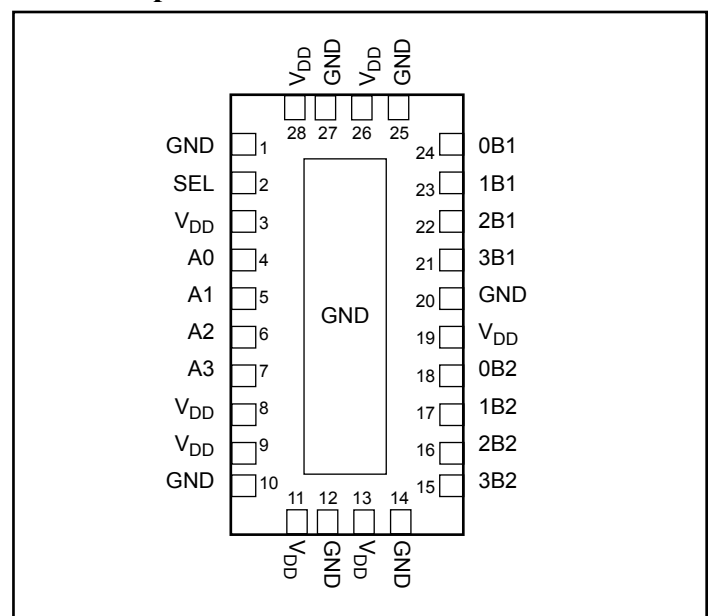



**PI2PCIE212**  
**1.8V, PCI Express Compliant, 2 Differential Ch.,**  
**2:1 Mux/DeMux Switch w/ Single Enable**

**Maximum Ratings**

(Above which useful life may be impaired. For user guidelines, not tested.)

Storage Temperature .....	-65°C to +150°C
Supply Voltage to Ground Potential .....	-0.5V to +2.5V
DC Input Voltage .....	-0.5V to +V <sub>CC</sub>
DC Output Current .....	120mA
Power Dissipation .....	0.5W

**Note:** Stresses greater than those listed under MAXIMUM RATINGS may cause permanent damage to the device. This is a stress rating only and functional operation of the device at these or any other conditions above those indicated in the operational sections of this specification is not implied. Exposure to absolute maximum rating conditions for extended periods may affect reliability.

www.DataSheet4U.com

**DC Electrical Characteristics for Switching over Operating Range**

(T<sub>A</sub> = -40°C to +85°C, V<sub>CC</sub> = 1.5V to 2.0V)

Parameter	Description	Test Conditions	Min.	Typ. <sup>(2)</sup>	Max.	Units
V <sub>IH</sub>	Input HIGH Voltage	Guaranteed HIGH level	0.65 x V <sub>CC</sub>	-	-	V
V <sub>IL</sub>	Input LOW Voltage	Guaranteed LOW level	-0.5	-	0.35 x V <sub>CC</sub>	
V <sub>IK</sub>	Clamp Diode Voltage	V <sub>CC</sub> = Max., I <sub>IN</sub> = -18mA	-	-0.7	-1.2	
I <sub>IH</sub>	Input HIGH Current	V <sub>CC</sub> = Max., V <sub>IN</sub> = V <sub>CC</sub>	-	-	±5	μA
I <sub>IL</sub>	Input LOW Current	V <sub>CC</sub> = Max., V <sub>IN</sub> = GND	-	-	±5	

**Power Supply Characteristics**

Parameters	Description	Test Conditions <sup>(1)</sup>	Min.	Typ. <sup>(2)</sup>	Max.	Units
I <sub>CC</sub>	Quiescent Power Supply Current	V <sub>CC</sub> = Max., V <sub>IN</sub> = GND or V <sub>CC</sub>		200		μA

**Notes:**

1. For Max. or Min. conditions, use appropriate value specified under Electrical Characteristics for the applicable device type.
2. Typical values are at V<sub>CC</sub> = 1.8V, T<sub>A</sub> = 25°C ambient and maximum loading.

**Dynamic Electrical Characteristics Over the Operating Range** (T<sub>A</sub> = -40° to +85°C, V<sub>CC</sub> = 1.8V±10%, GND=0V)

Parameter	Description	Test Conditions	Min.	Typ. <sup>(2)</sup>	Max.	Units
X <sub>TALK</sub>	Crosstalk	See Fig. 1 for Measurement Setup, f = 10 MHz		-60		dB
O <sub>IRR</sub>	OFF Isolation	See Fig. 2 for Measurement Setup, f = 10 MHz		-65		

**Notes:**

1. Guaranteed by design.

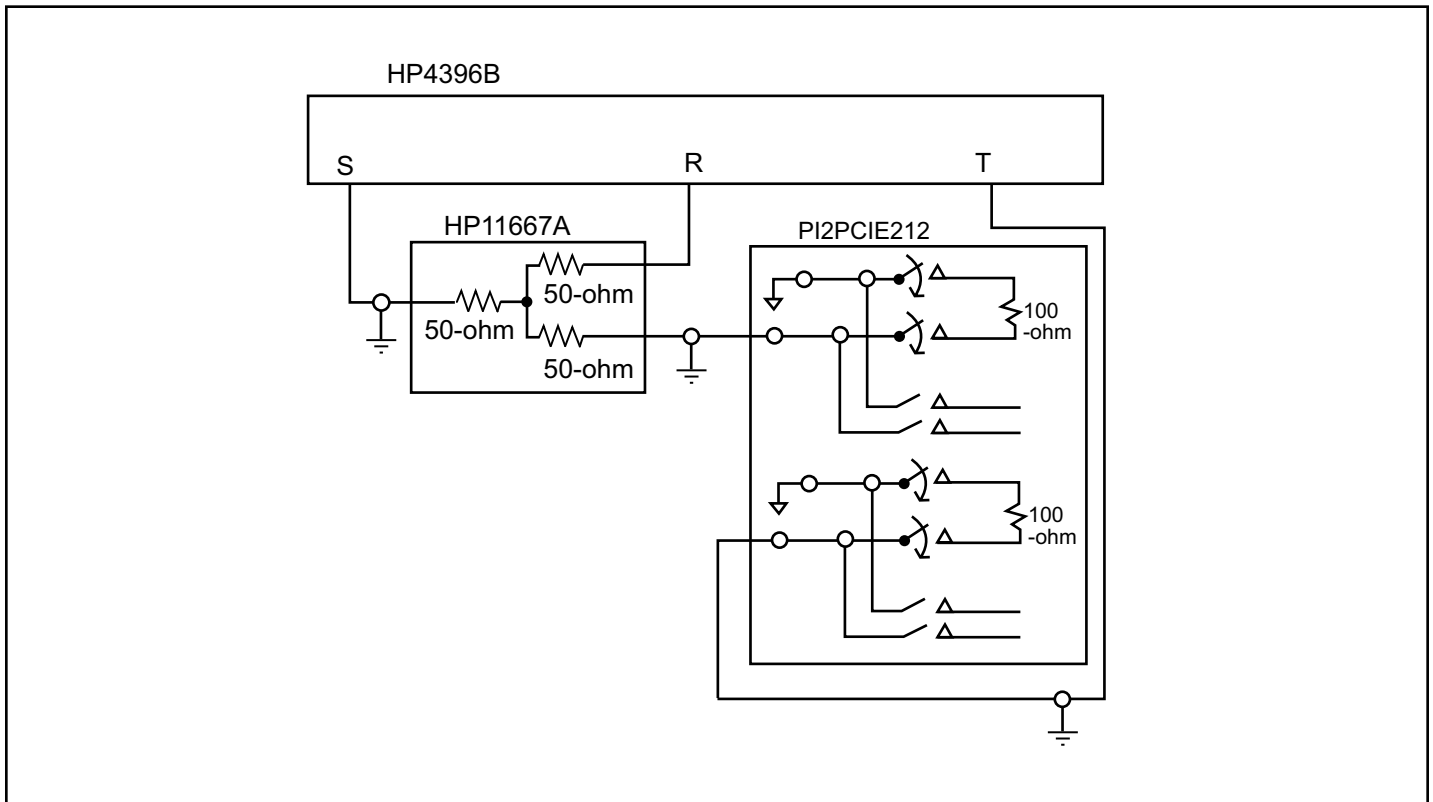

**Fig 1. Crosstalk Setup**

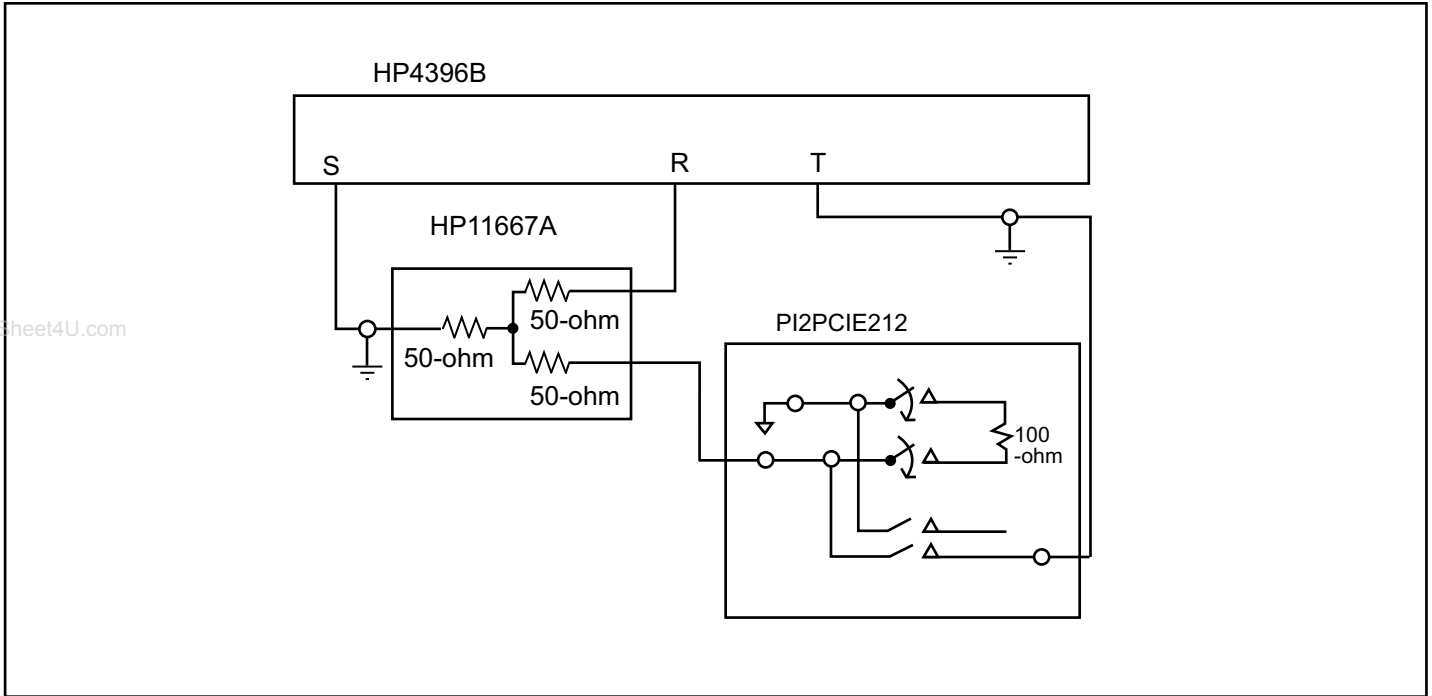

**Fig 2. Off-isolation setup**

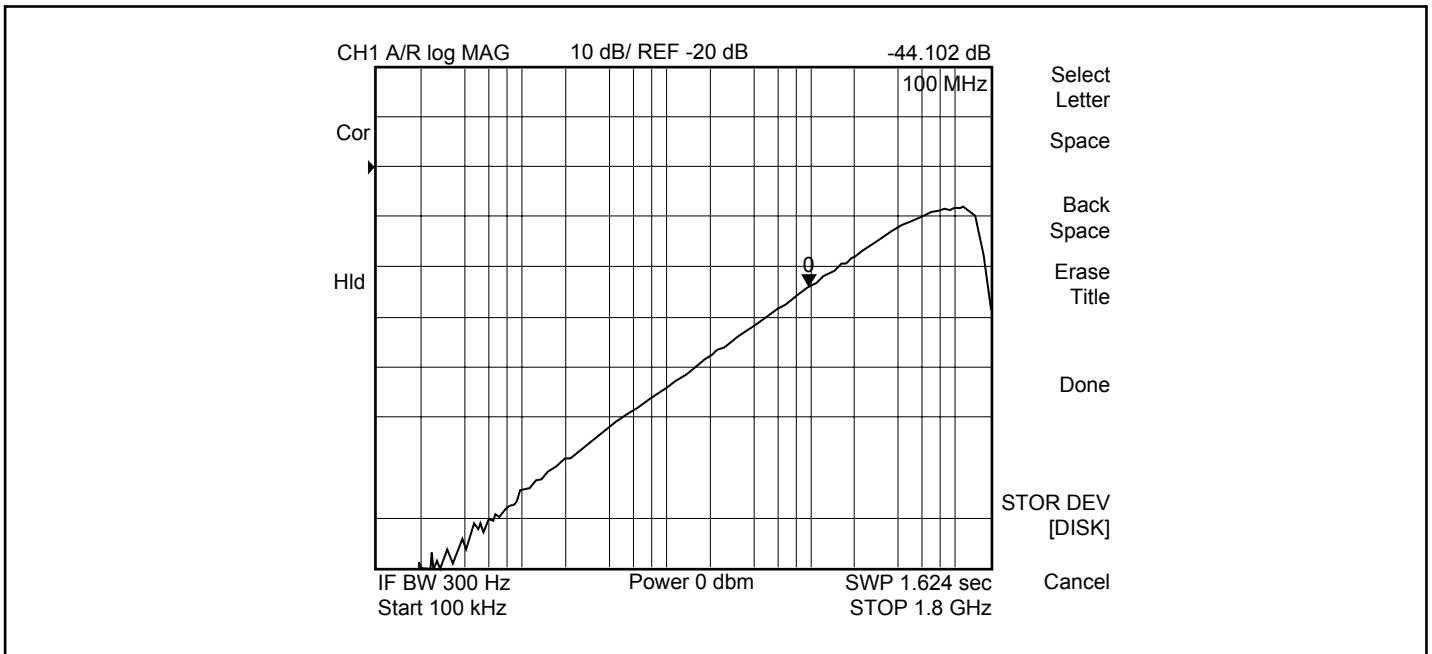

**Fig 3. Crosstalk**

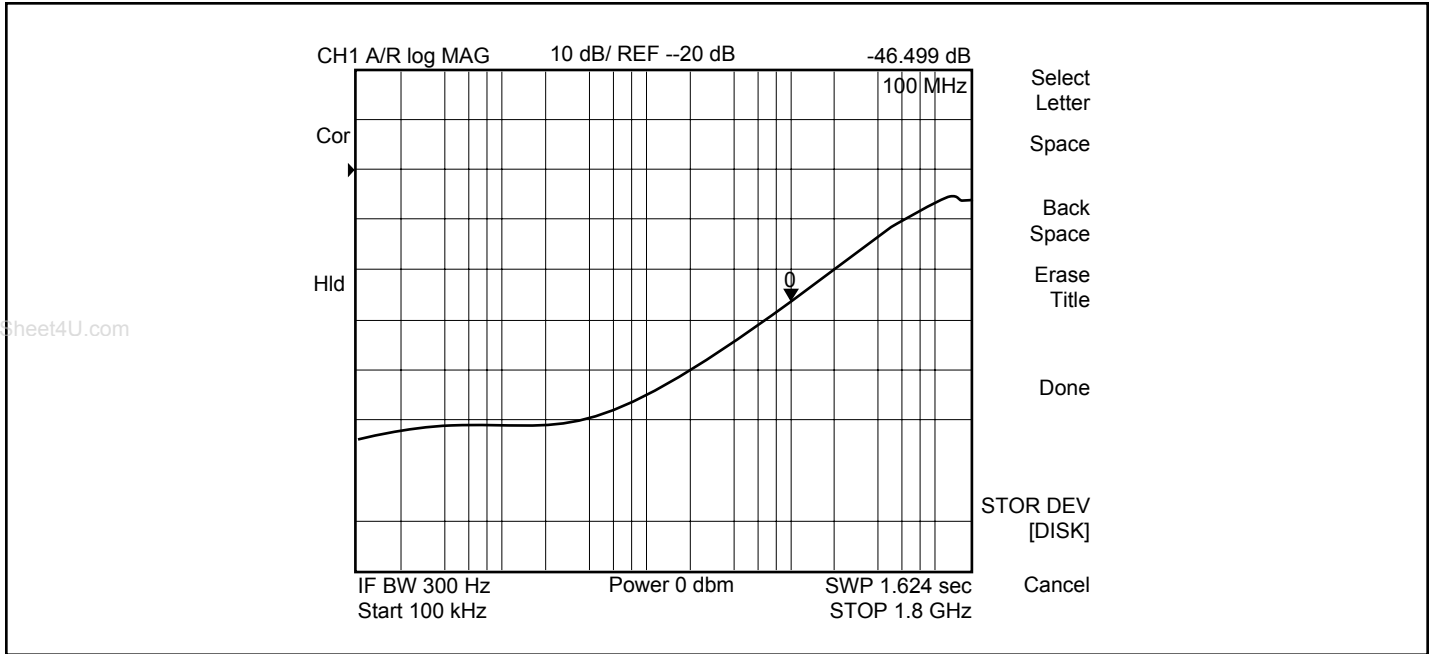

**Fig 4. Off Isolation**

**Switching Characteristics** ( $T_A = -40^\circ$  to  $+85^\circ\text{C}$ ,  $V_{CC} = 1.8\text{V} \pm 10\%$ )

Parameter	Description	Min.	Typ. <sup>(2)</sup>	Max.	Units
tPZH, tPZL	Line Enable Time - SEL to A <sub>N</sub> , B <sub>N</sub>	0.5	-	8.0	
tPHZ, tPLZ	Line Disable Time - SEL to A <sub>N</sub> , B <sub>N</sub>	0.5	-	4.0	

**Notes:**

- For max. or min. conditions, use appropriate value specified under Electrical Characteristics for the applicable device type.

### Test Circuit for Electrical Characteristics<sup>(1)</sup>

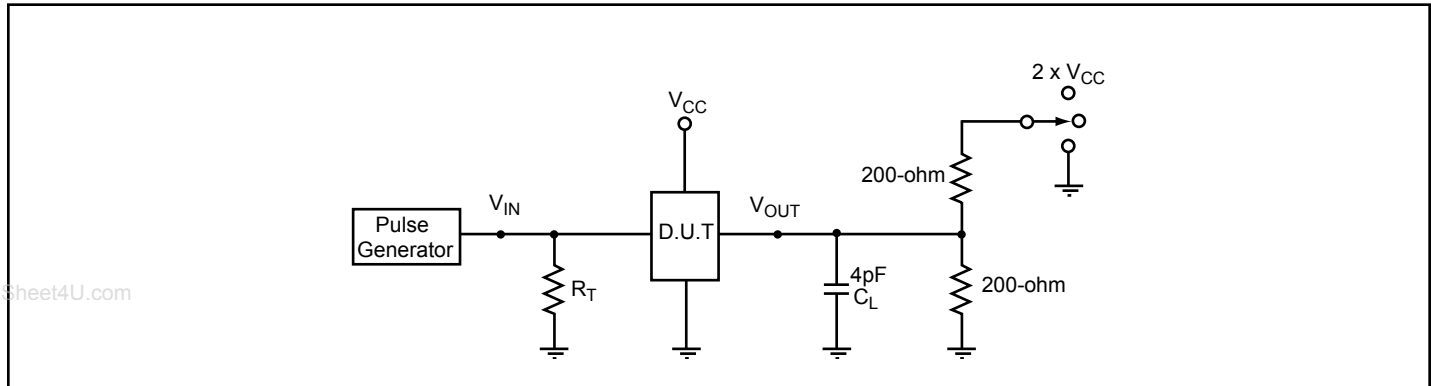

**Notes:**

1.  $C_L$  = Load capacitance: includes jig and probe capacitance.
2.  $R_T$  = Termination resistance: should be equal to  $Z_{OUT}$  of the Pulse Generator
3. Waveform 1 is for an output with internal conditions such that the output is low except when disabled by the output control.  
Waveform 2 is for an output with internal conditions such that the output is high except when disabled by the output control.
4. All input impulses are supplied by generators having the following characteristics:  $PRR \leq \text{MHz}$ ,  $Z_O = 50\Omega$ ,  $t_R \leq 2.5\text{ns}$ ,  $t_F \leq 2.5\text{ns}$ .
5. The outputs are measured one at a time with on transition per measurement.

### Switch Positions

Test	Switch
$t_{PLZ}$ , $t_{PZL}$ (output on I-side)	$2 \times V_{CC}$
$t_{PHZ}$ , $t_{PZH}$ (output on I-side)	GND
Prop Delay	Open

### Test Circuit for Dynamic Electrical Characteristics

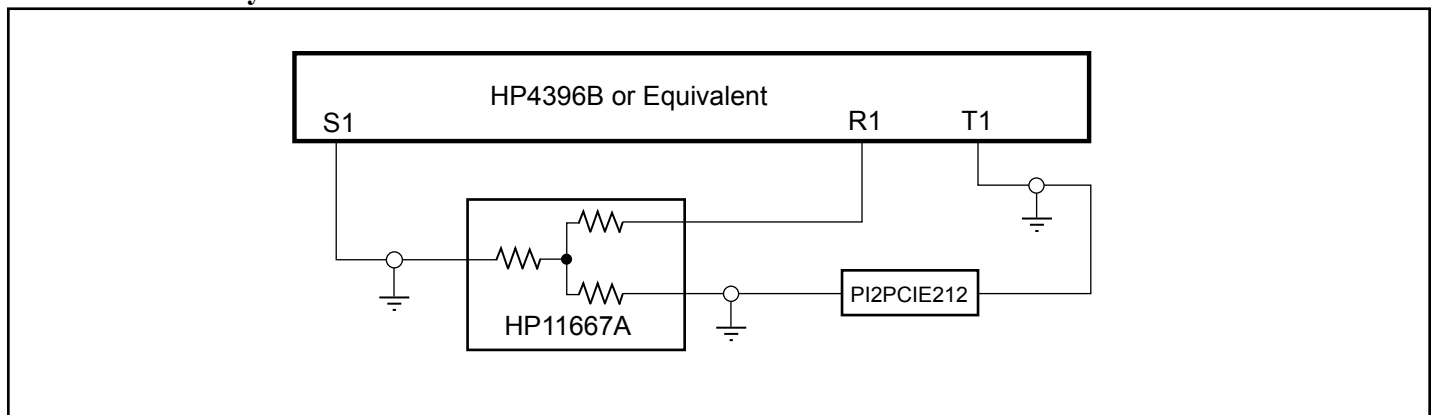

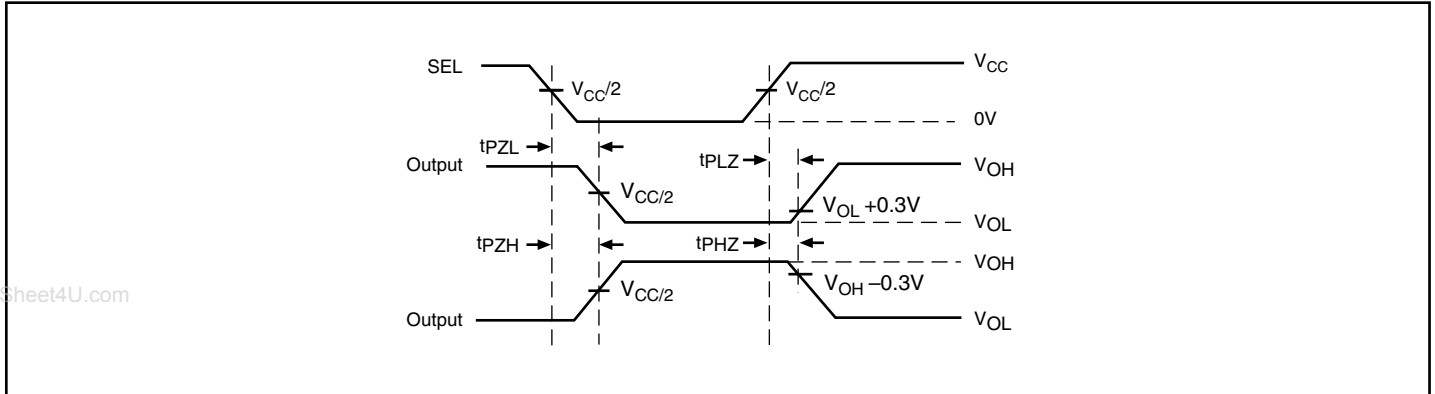
**Switching Waveforms**

**Voltage Waveforms Enable and Disable Times**

www.DataSheet4U.com

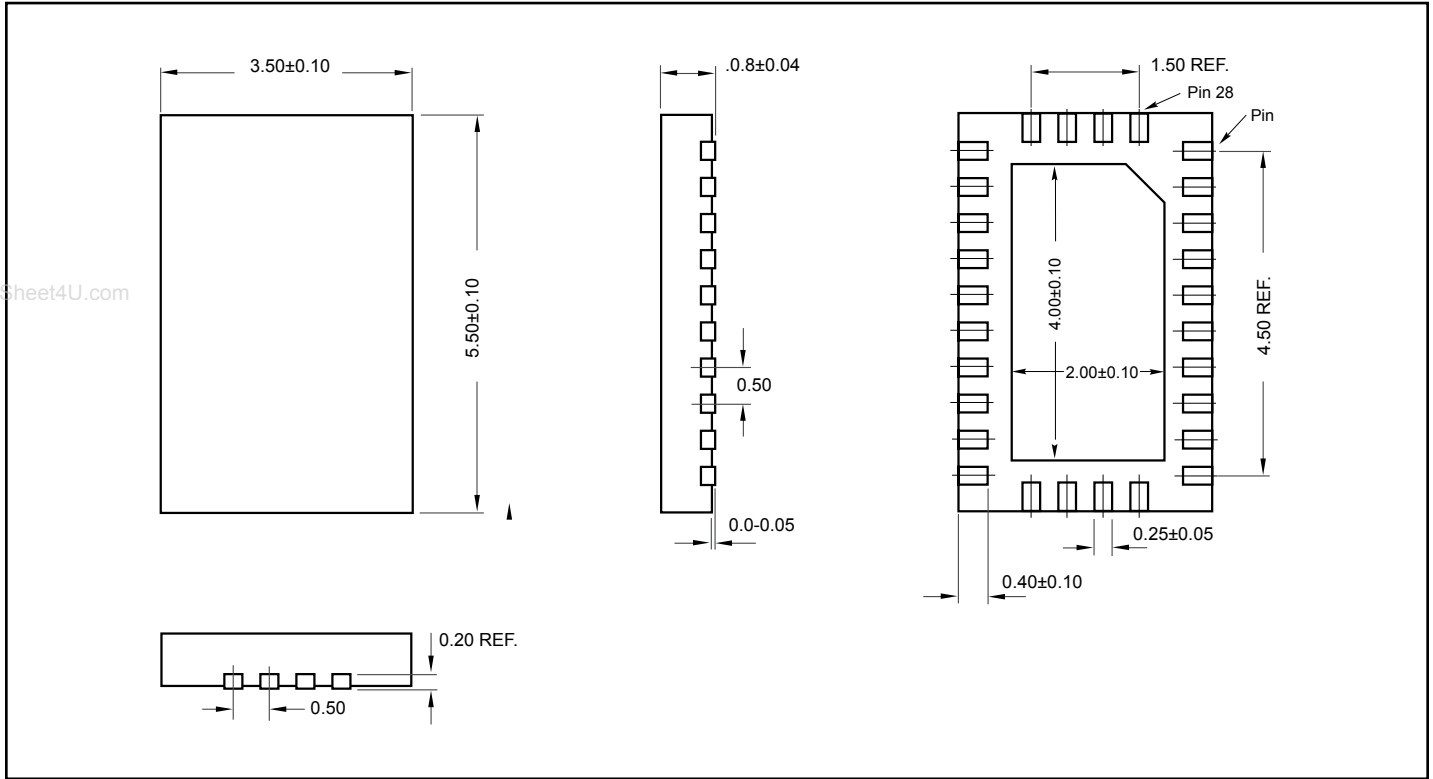
**Package Mechanical: 28-Contact TQFN (ZH)**



**Ordering Information**

Ordering Code	Package Code	Package Type
PI2PCIE212ZHE	ZH	Pb-free & Green, 28-Contact TQFN

**Notes:**

1. Thermal characteristics can be found on the company web site at [www.pericom.com/packaging/](http://www.pericom.com/packaging/)