

## 1.8V, PCI Express Gen-II Compliant, 4-Differential Channel, 2:1 Mux/DeMux Switch, w/ Single Enable

### Features

- 4 Differential Channel, 2:1 Mux/DeMux
- PCI Express, Gen II Performance, 5.0Gbps
- Low Bit-to-Bit Skew , 7ps max (between '+' and '-' bits)
- Low Crosstalk: -23dB@3 GHz
- Low Off Isolation: -23dB@3 GHz
- V<sub>CC</sub> Operating Range: +1.5V to +2.0V
- ESD Tolerance: 8kV HBM I/O; 2kV HBM select pin
- Low channel-to-channel skew, 35ps max
- Packaging (Pb-free & Green):
  - 42-contact, TQFN (ZH42)

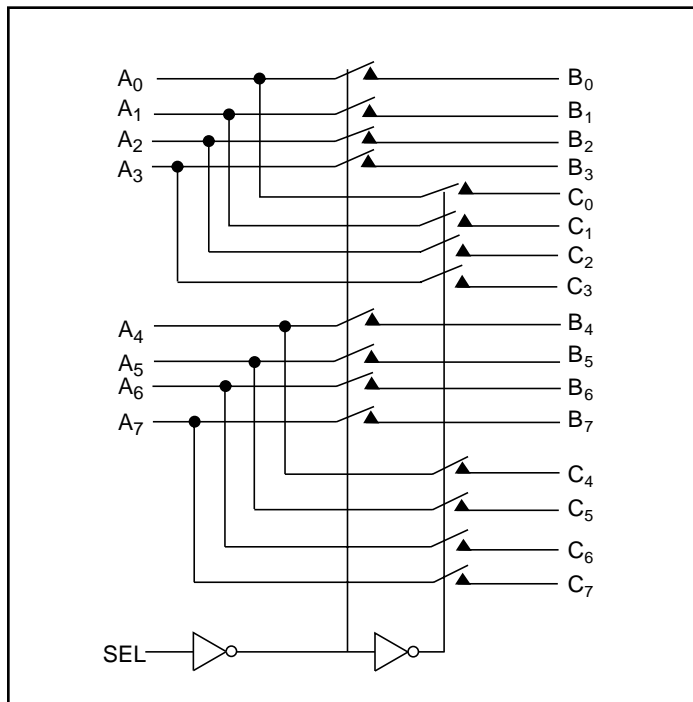
### Description

Pericom Semiconductor's PI2PCIE2412 is an 8 to 4 differential channel multiplexer/demultiplexer switch. This solution can switch 2 full PCI Express, Gen-II, lanes to one of two locations. Using a unique design technique, Pericom has been able to minimize the impedance of the switch such that the attenuation observed through the switch is negligible. The unique design technique also offers a layout targeted for PCI Express signals, which minimizes the channel to channel skew as well as channel to channel crosstalk as required by the PCI Express specification.

### Application

Routing of PCI-Express, Gen-II, signals with low signal attenuation.

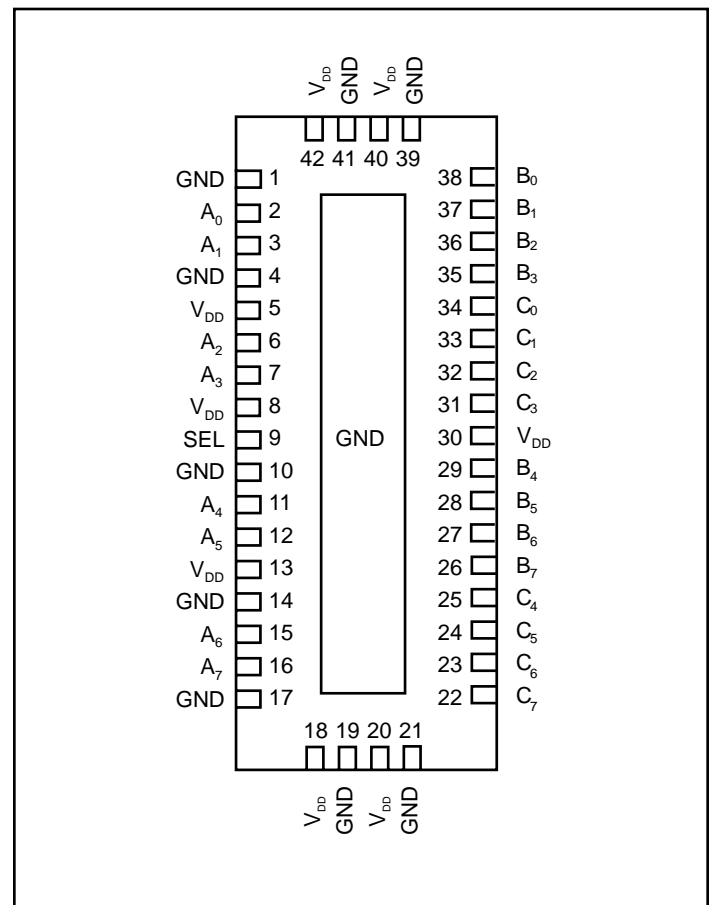
### Block Diagram



### Truth Table

Function	SEL
A <sub>N</sub> to B <sub>N</sub>	L
A <sub>N</sub> to C <sub>N</sub>	H

### Pin Description



### Maximum Ratings

(Above which useful life may be impaired. For user guidelines, not tested.)

Storage Temperature .....	-65°C to +150°C
Supply Voltage to Ground Potential .....	-0.5V to +2.5V
DC Input Voltage .....	-0.5V to $V_{CC}$
DC Output Current .....	120mA
Power Dissipation .....	0.5W

**Note:** Stresses greater than those listed under MAXIMUM RATINGS may cause permanent damage to the device. This is a stress rating only and functional operation of the device at these or any other conditions above those indicated in the operational sections of this specification is not implied. Exposure to absolute maximum rating conditions for extended periods may affect reliability.

www.DataSheet4U.com

### DC Electrical Characteristics for Switching over Operating Range ( $T_A = -40^\circ\text{C}$ to $+85^\circ\text{C}$ , $V_{CC} = 1.5\text{V}$ to $2.0\text{V}$ )

Parameter	Description	Test Conditions <sup>(1)</sup>	Min	Typ <sup>(2)</sup>	Max	Units
$V_{IH}$	Input HIGH Voltage	Guaranteed HIGH level	$0.65 \times V_{CC}$			V
$V_{IL}$	Input LOW Voltage	Guaranteed LOW level	-0.5		$0.35 \times V_{CC}$	
$V_{IK}$	Clamp Diode Voltage	$V_{CC} = \text{Max.}, I_{IN} = -18\text{mA}$		-0.7	-1.2	
$I_{IH}$	Input HIGH Current	$V_{CC} = \text{Max.}, V_{IN} = V_{CC}$			$\pm 5$	$\mu\text{A}$
$I_{IL}$	Input LOW Current	$V_{CC} = \text{Max.}, V_{IN} = \text{GND}$			$\pm 5$	

### Power Supply Characteristics

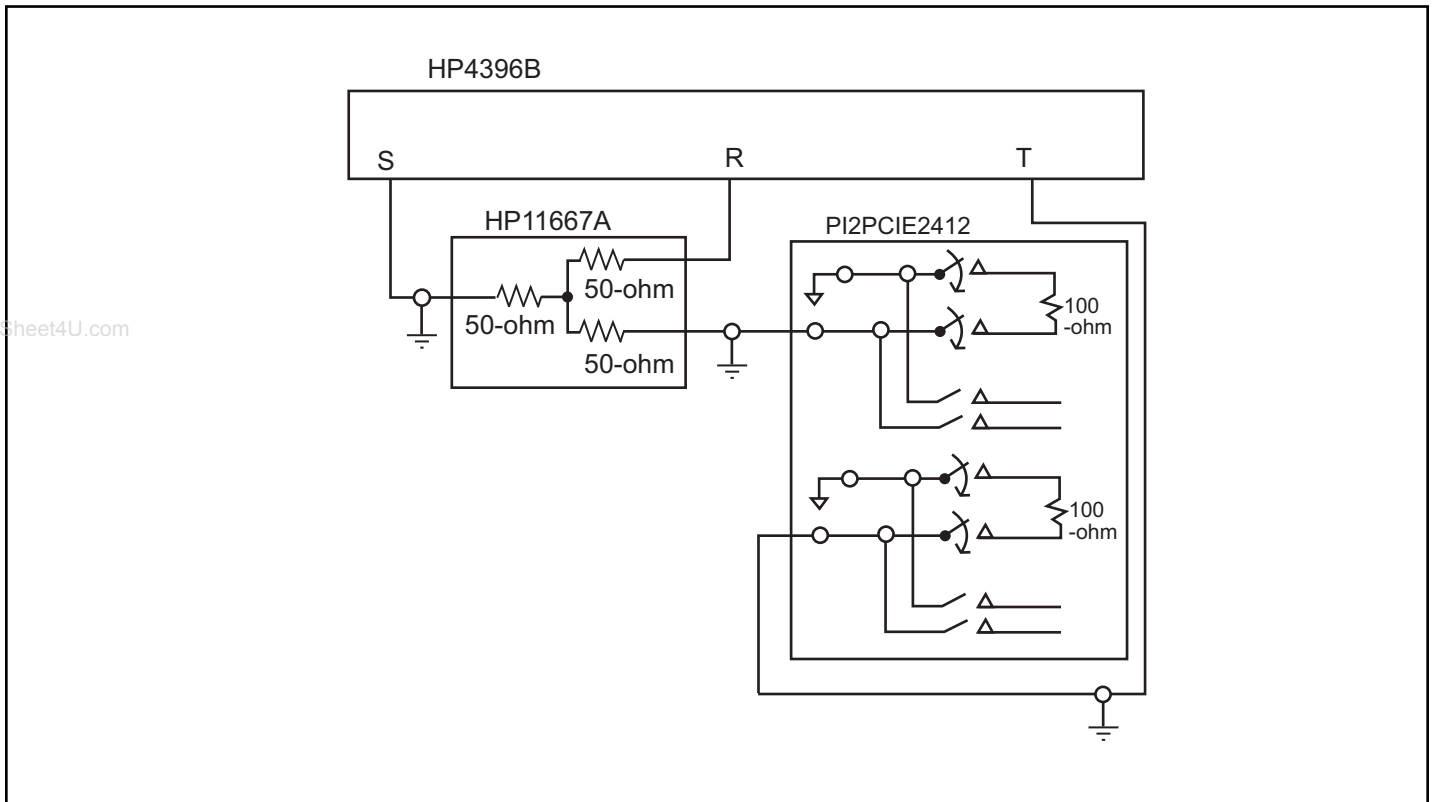
Parameters	Description	Test Conditions <sup>(1)</sup>	Min.	Typ. <sup>(2)</sup>	Max.	Units
$I_{CC}$	Quiescent Power Supply Current	$V_{CC} = \text{Max.}, V_{IN} = \text{GND}$ or $V_{CC}$		200		$\mu\text{A}$

### Dynamic Electrical Characteristics Over the Operating Range ( $T_A = -40^\circ$ to $+85^\circ\text{C}$ , $V_{CC} = 1.8\text{V} \pm 10\%$ , $\text{GND} = 0\text{V}$ )

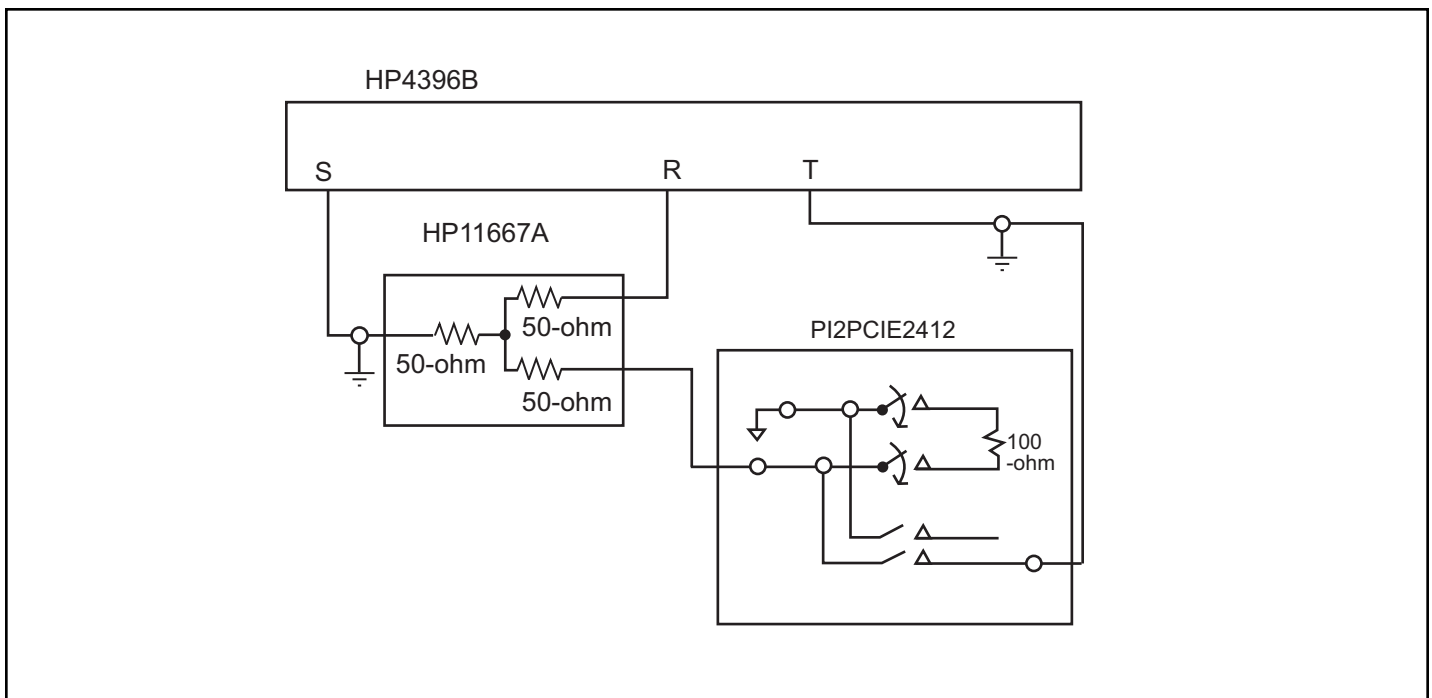
Parameter	Description	Test Conditions	Min.	Typ. <sup>(2)</sup>	Max.	Units
$X_{TALK}$	Crosstalk	See Fig. 1 for Measurement Setup, $f = 3\text{ GHz}$ $f = 100\text{ MHz}$		-23dB -58dB		dB
$O_{IRR}$	OFF Isolation	See Fig. 2 for Measurement Setup, $f = 3\text{ GHz}$ $f = 100\text{ MHz}$		-23dB -58dB		
$I_{LOSS}$	Differential Insertion Loss	$f = 3\text{ GHz}$		-2		dB
BW	Bandwidth -3dB			4.1		GHz

#### Notes:

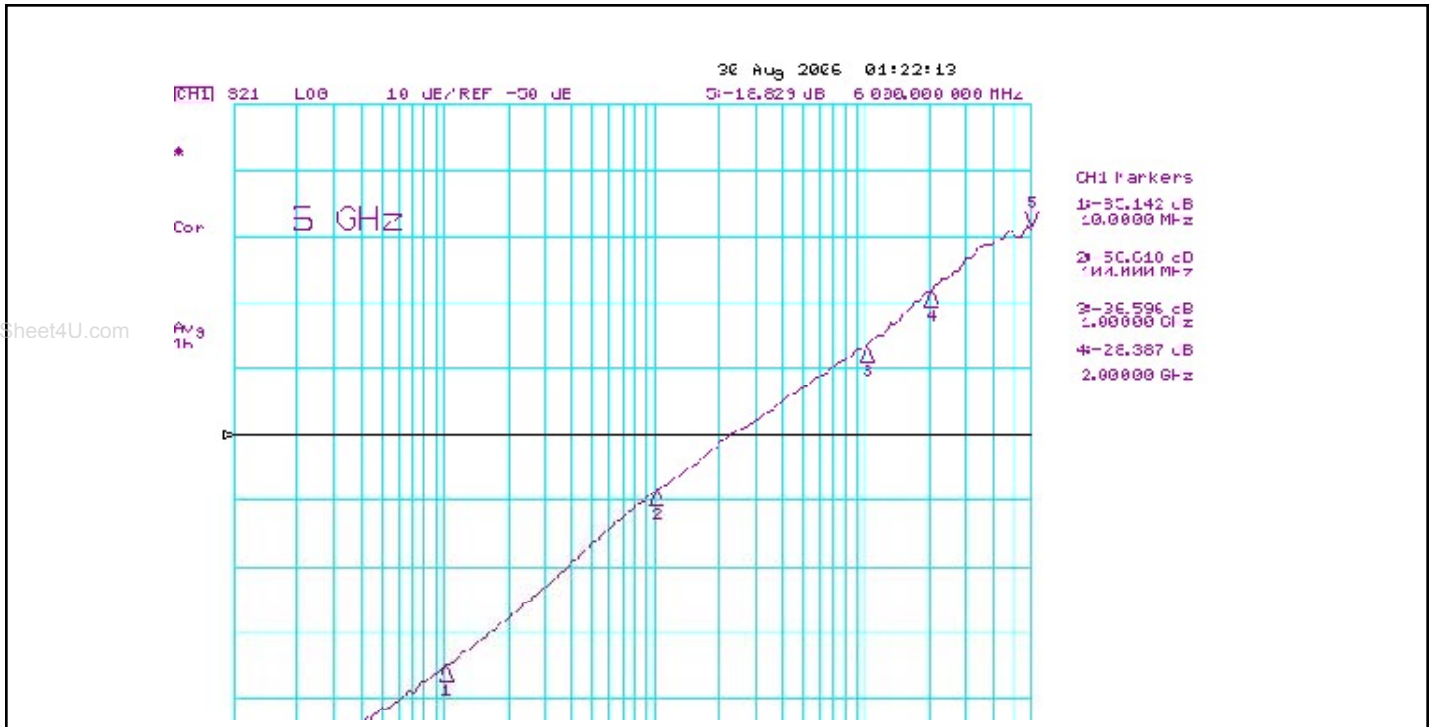
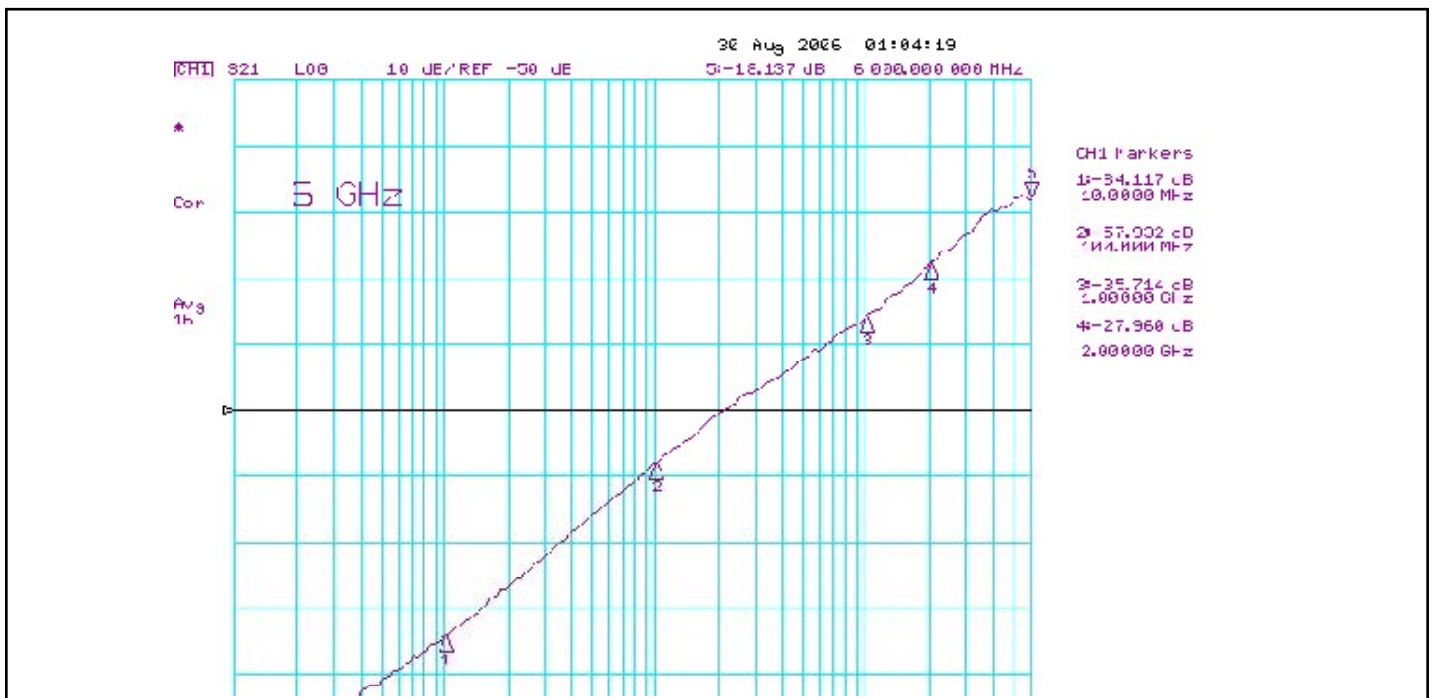
- For Max. or Min. conditions, use appropriate value specified under Electrical Characteristics for the applicable device type.
- Typical values are at  $V_{CC} = 1.8\text{V}$ ,  $T_A = 25^\circ\text{C}$  ambient and maximum loading.

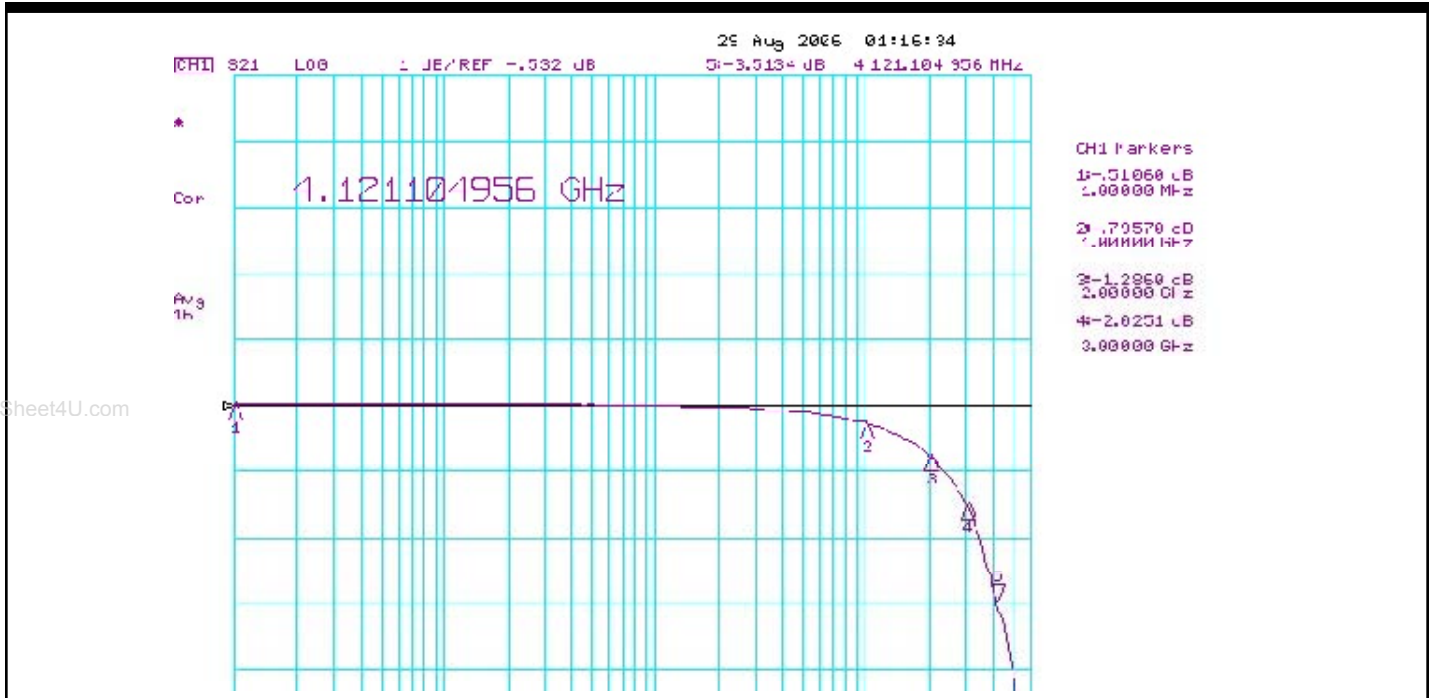


**Fig 1. Crosstalk Setup**



**Fig 2. Off-isolation setup**


**Fig 3. Crosstalk**

**Fig 4. Off Isolation**

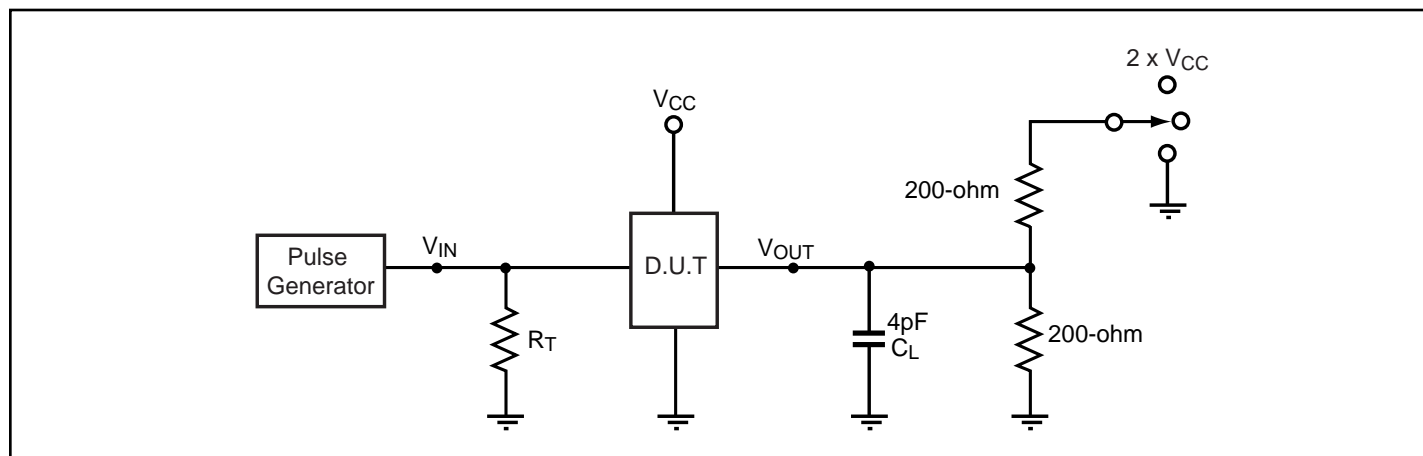


**Fig 5. Insertion Loss**

**Switching Characteristics** ( $T_A = -40^\circ$  to  $+85^\circ\text{C}$ ,  $V_{CC} = 1.8\text{V} \pm 10\%$ )

Parameter	Description	Min.	Max.	Units
$t_{PZH}$ , $t_{PZL}$	Line Enable Time - SEL to $A_N$ , $B_N$	0.5	8.0	ns
$t_{PHZ}$ , $t_{PLZ}$	Line Disable Time - SEL to $A_N$ , $B_N$	0.5	8.0	
$t_{b-b}$	Bit-to-bit skew within the same differential pair		7	ps
$t_{ch-ch}$	Channel-to-channel skew		35	ps

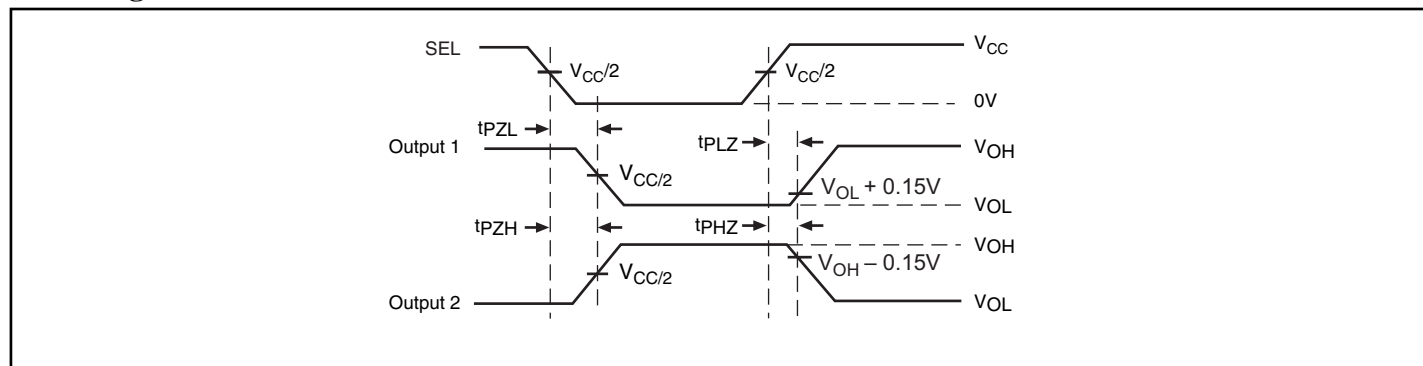
**Test Circuit for Electrical Characteristics<sup>(1-5)</sup>**



**Notes:**

- $C_L$  = Load capacitance: includes jig and probe capacitance.
- $R_T$  = Termination resistance: should be equal to  $Z_{OUT}$  of the Pulse Generator
- Output 1 is for an output with internal conditions such that the output is low except when disabled by the output control.  
output 2 is for an output with internal conditions such that the output is high except when disabled by the output control.
- All input impulses are supplied by generators having the following characteristics:  $PRR \leq \text{MHz}$ ,  $Z_O = 50\Omega$ ,  $t_R \leq 2.5\text{ns}$ ,  $t_F \leq 2.5\text{ns}$ .
- The outputs are measured one at a time with one transition per measurement.

**Switching Waveforms**

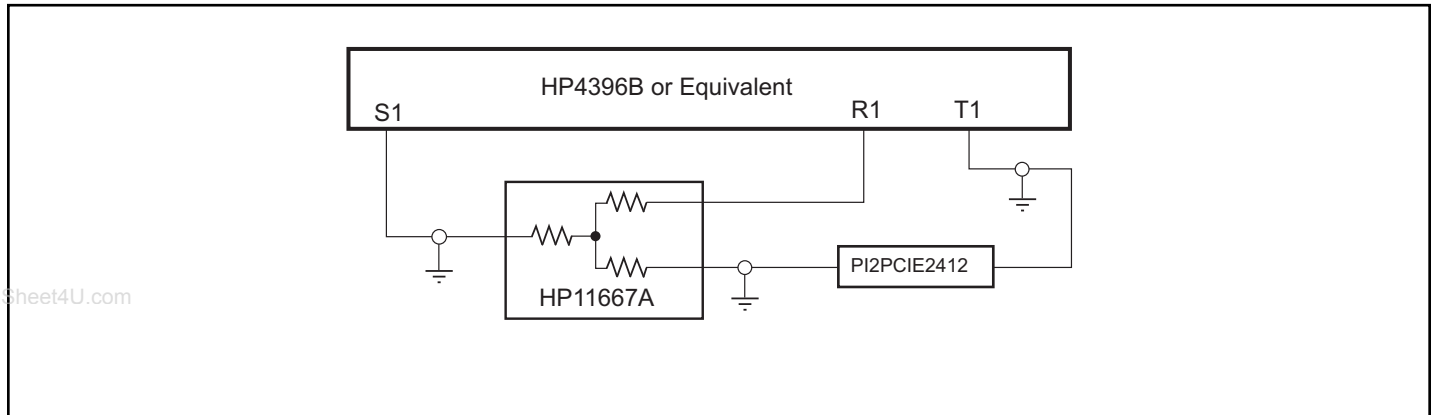


**Voltage Waveforms Enable and Disable Times**

**Switch Positions**

Test	Switch
$t_{PLZ}$ , $t_{PZL}$ (output on B-side)	$2 \times V_{CC}$
$t_{PHZ}$ , $t_{PHZ}$ (output on B-side)	GND
Prop Delay	Open

**Test Circuit for Dynamic Electrical Characteristics**



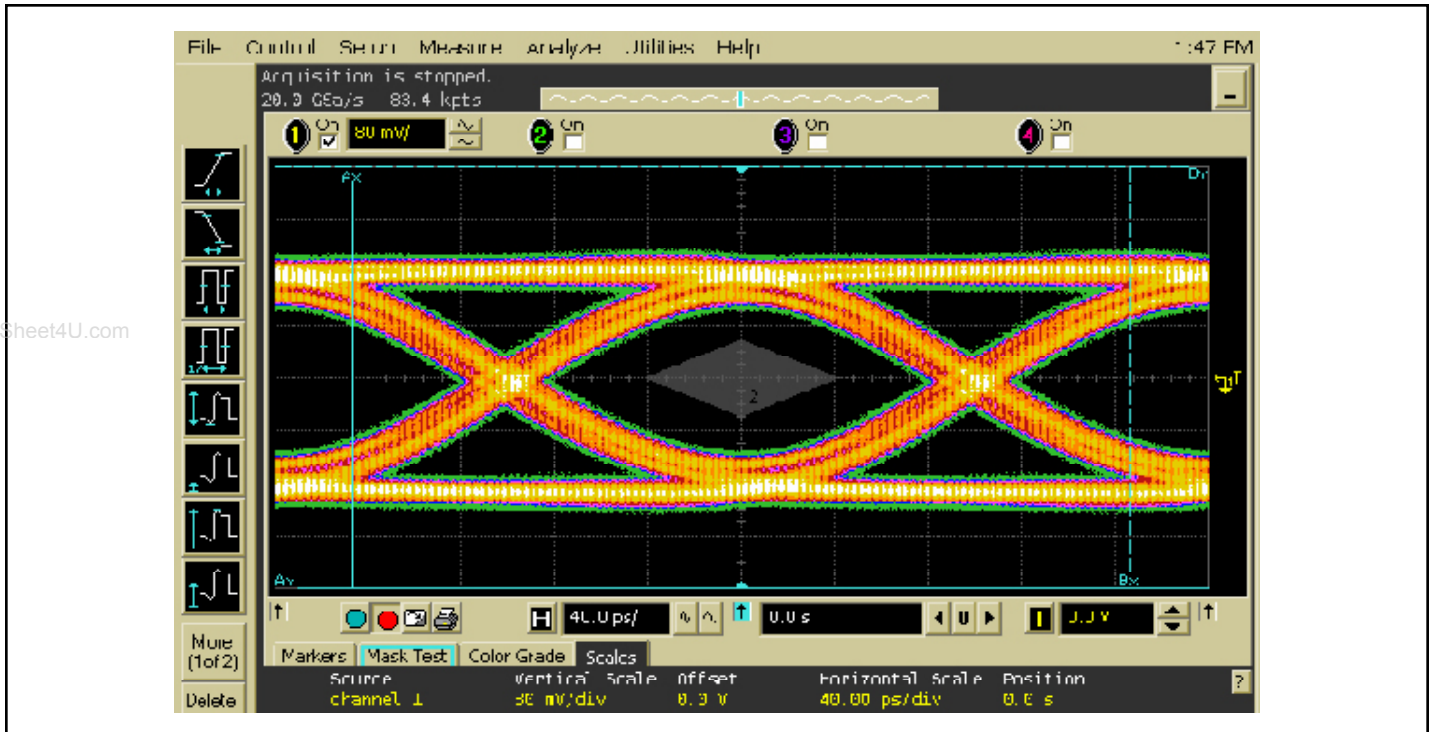
**Applications Information**

*Rail-to-Rail is a registered trademark of Nippon Motorola, Ltd*

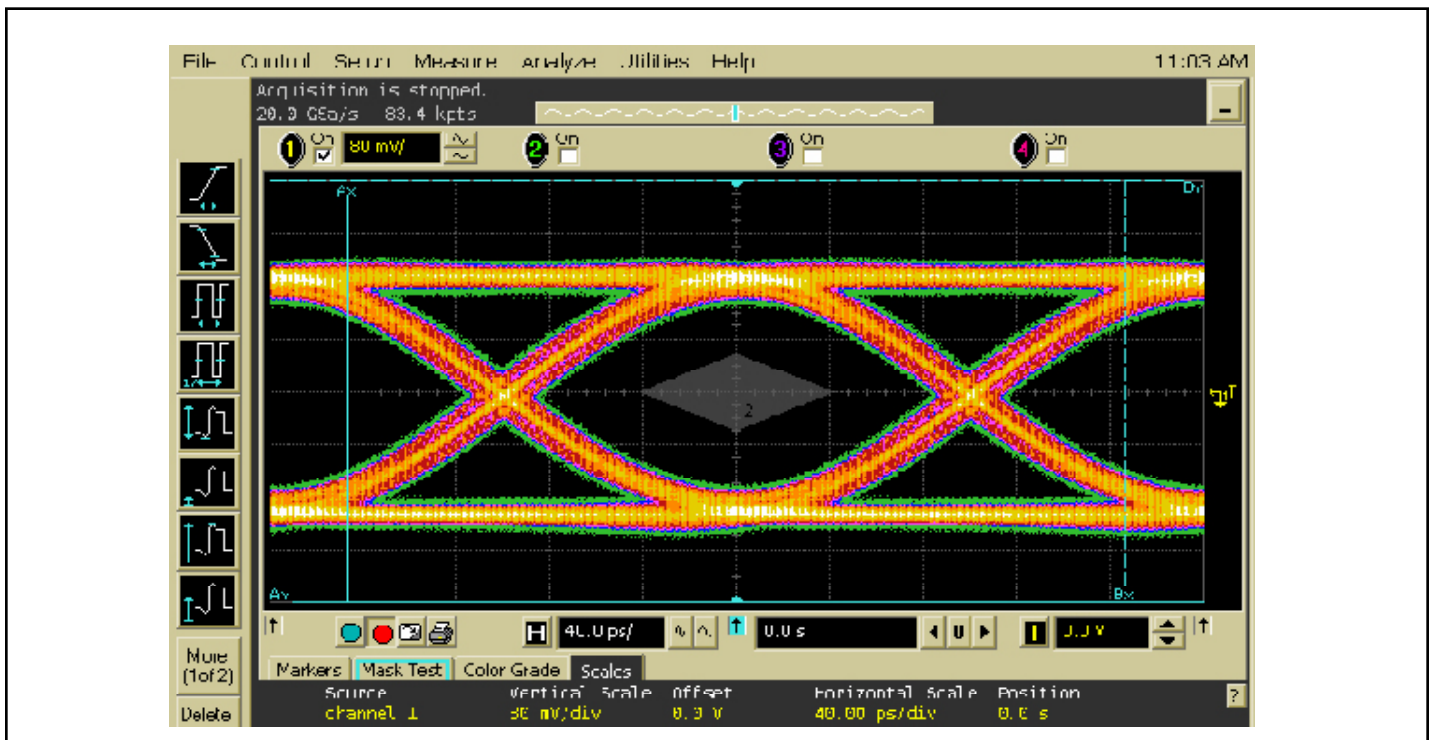
**PCI Express Application Specific Measurements and Test Set-up**



**Figure 5: Test Setup**



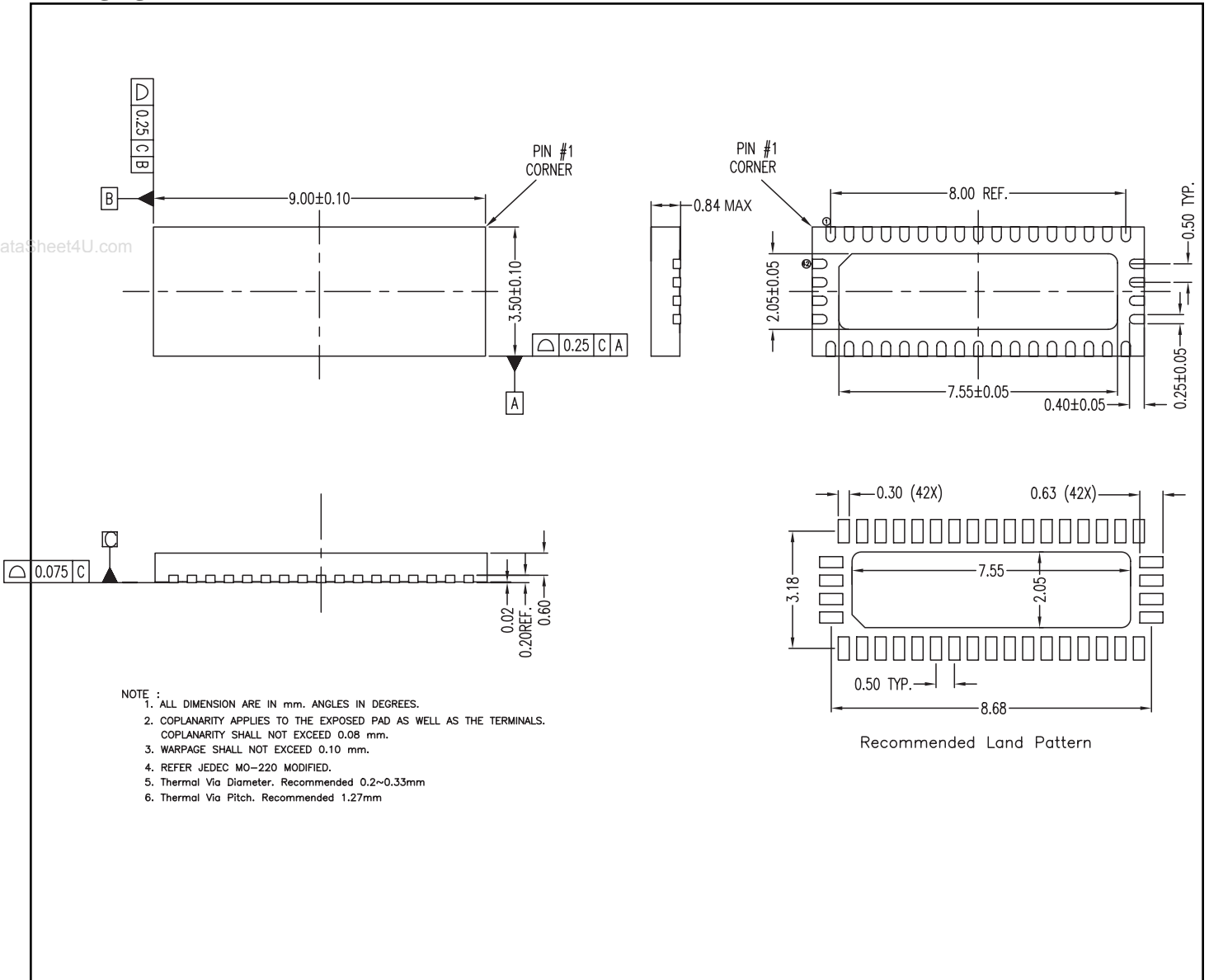
**Figure 6: 5 Gbps RX signal eye of the PCI-SIG compliance software test using PI2PCIE2412 + 16" test card**



**Figure 7: 5 Gbps RX signal eye of the PCI-SIG compliance software test with no switch + w/ 16" test card**



**Packaging Mechanical: 42-Contact TQFN (ZH)**



**Ordering Information**

Ordering Code	Package Code	Package Description
PI2PCIE2412ZHE	ZH	Pb-free & Green, 42-contact TQFN

**Notes:**

- Thermal characteristics can be found on the company web site at [www.pericom.com/packaging/](http://www.pericom.com/packaging/)
- "E" denotes Pb-free and Green
- Adding an "X" at the end of the ordering code denotes tape and reel packaging