

8 V to 18 Vin, 15 A Cool-Power ZVS Buck Regulator

Product Description

The PI34xx-00 is a family of high efficiency DC-DC ZVS-Buck regulators integrating the controller, power switches and support components within a high density System-in-Package (SiP).

The PI34xx-00 is designed to achieve optimum efficiency at low input voltage ranges (8 V to 18 V). The utilization of zero current soft turn-on provided by the high performance ZVS topology within the PI34xx-00 series increases point of load performance, providing best in class power efficiency with high throughput power.

The PI34xx-00 requires only an external inductor and minimal capacitors to form a complete DC-DC switching mode buck regulator.

Device	Output Voltage		I _{OUT} Max
	Set	Range	
PI3420-00-LGIZ	1.0 V	1.0 V to 1.4 V	15 A
PI3421-00-LGIZ	1.8 V	1.4 V to 2.0 V	15 A
PI3422-00-LGIZ	2.5 V	2.0 V to 3.1 V	15 A
PI3423-00-LGIZ	3.3 V	2.3 V to 4.1 V	15 A
PI3424-00-LGIZ	5.0 V	3.3 V to 6.5 V	15 A

The ZVS architecture enables high frequency operation while minimizing switching losses and maximizing efficiency. The high switching frequency operation reduces the size of the external filtering components, improves power density, and enables very fast dynamic response to line and load transients.

The ZVS architecture enables operation up to 750 kHz while minimizing switching losses and the use of variable frequency extends high efficiency over a very wide dynamic range. The PI34xx-00 series has a minimum on time of 20ns which enables large step down conversion ratios.

Features & Benefits

- High Efficiency ZVS-Buck Topology
- Input voltage range of 8 V to 18 V
- Very-Fast transient response
- Power-up into pre-biased load
- High accuracy pre-trimmed output voltage
- User adjustable soft-start & tracking
- Parallel capable with single wire current sharing
- Input Over/Undervoltage Lockout (OVLO/UVLO)
- Output Overvoltage Protection (OVP)
- Overtemperature Protection (OTP)
- Fast and slow current limits
- -40°C to 125°C operating range (T_J)

Applications

- High efficiency systems
- Computing, Communications, Industrial, Automotive Equipment

Package Information

- 10 mm x 14 mm x 2.6 mm LGA SiP



Contents

Contents	Page
Order Information	3
Thermal, Storage, and Handling Information	3
Absolute Maximum Ratings	4
Functional Block Diagram	4
Pin Description	5
Package Pin-Out	5
PI3420-00-LGIZ Electrical Characteristics	6
PI3421-00-LGIZ Electrical Characteristics	9
PI3422-00-LGIZ Electrical Characteristics	12
PI3423-00-LGIZ Electrical Characteristics	15
PI3424-00-LGIZ Electrical Characteristics	18
Thermal Derating Curves	21
Functional Description	22
ENABLE	22
Remote Sensing	22
Switching Frequency Synchronization	22
Soft-Start	22
Output Voltage Trim	22
Output Current Limit Protection	22
Input Undervoltage Lockout	22
Input Overvoltage Lockout	22
Output Ovevoltage Protection	23
Overtemperature Protection	23
Parallel Operation	23
Pulse Skip Mode (PSM)	23
Variable Frequency Operation	23

Contents	Page
Application Description	23
Output Voltage Trim	23
Soft-Start Adjust and Tracking	24
Inductor Pairing	25
Thermal Derating	25
Filter Considerations	25
Layout Guidelines	26
Recommended PCB Footprint and Stencil	27
Package Drawings	28
Revision History	29
Warranty	30

Order Information

Cool-Power	Output Range		I _{OUT} Max	Package	Transport Media
	Set	Range			
PI3420-00-LGIZ	1.0 V	1.0 to 1.4 V	15 A	10 mm x 14 mm 123-pin LGA	TRAY
PI3421-00-LGIZ	1.8 V	1.4 to 2.0 V	15 A	10 mm x 14 mm 123-pin LGA	TRAY
PI3422-00-LGIZ	2.5 V	2.0 to 3.1 V	15 A	10 mm x 14 mm 123-pin LGA	TRAY
PI3423-00-LGIZ	3.3 V	2.3 to 4.1 V	15 A	10 mm x 14 mm 123-pin LGA	TRAY
PI3424-00-LGIZ	5.0 V	3.3 to 6.5 V	15 A	10 mm x 14 mm 123-pin LGA	TRAY

Thermal, Storage, and Handling Information

Name	Rating
Storage Temperature	-65°C to 150°C
Operating Junction Temperature	-40°C to 125°C
Soldering Temperature for 20 seconds	245°C
MSL Rating	2 kV HBM

Absolute Maximum Ratings

Name	Rating
V_{IN}	-0.7 V to 22 V
VS1	-0.7 to 22 V, 25 V for 5 ns, -4 V for 5 ns
V_{OUT}	See relevant product section
SGND	100 mA
PGD, SYNCO, SYNCI, EN, EAO, ADJ, TRK, ADR1, ADR2, SCL, SDA, REM	-0.3 V to 5.5 V / 5 mA

Notes: At 25°C ambient temperature. Stresses beyond these limits may cause permanent damage to the device. Operation at these conditions or conditions beyond those listed in the Electrical Characteristics is not guaranteed. All voltage nodes are referenced to PGND unless otherwise noted. Test conditions are per the specifications within the individual product Electrical Characteristics.

Functional Block Diagram

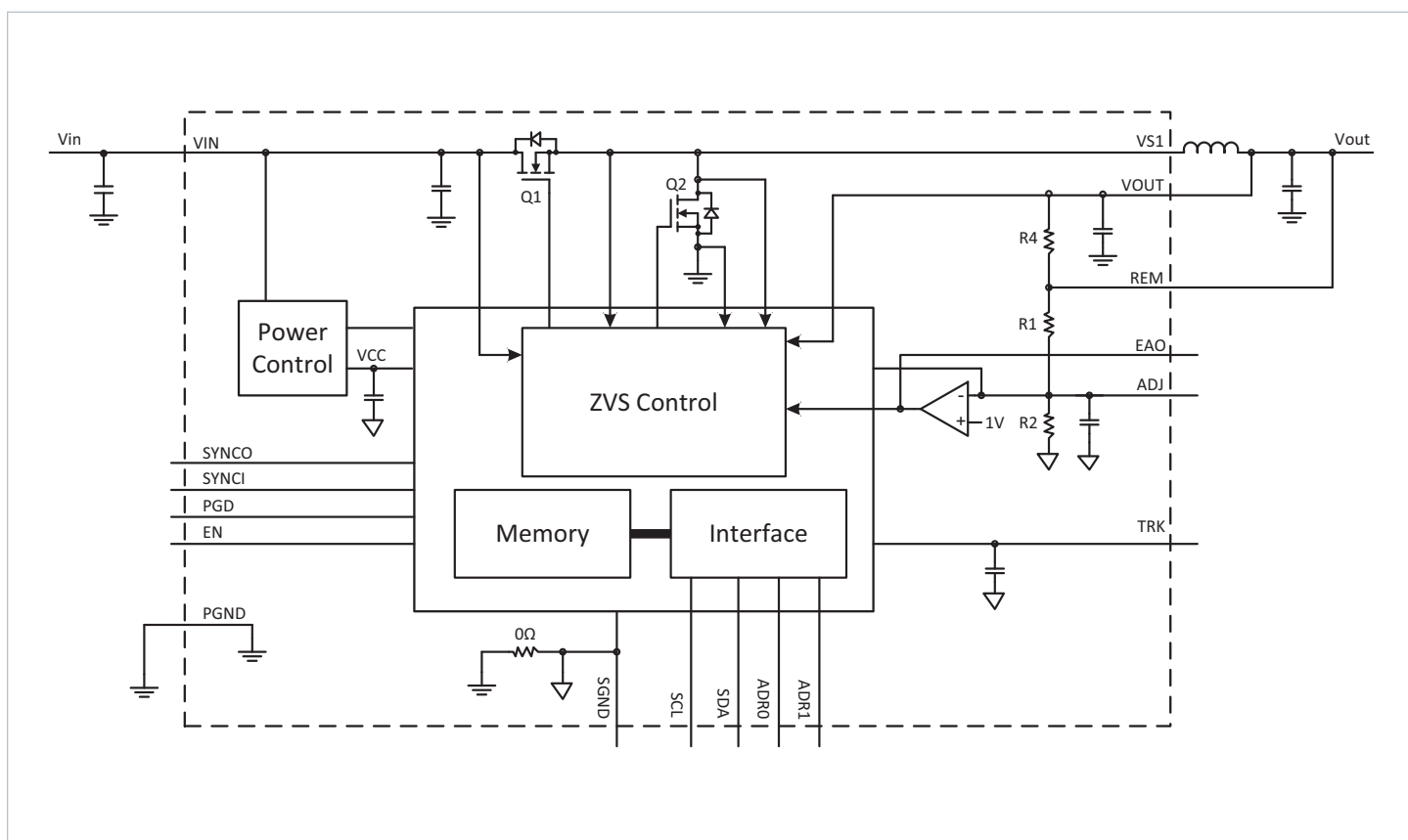

Simplified Block Diagram (I2C pins SCL, SDA, ADR0, and ADR1 are for factory use only. Not for use in application.)

Pin Description

Name	Location	Description
SGND	Block 1	Signal ground: Internal logic ground for EA, TRK, SYNCI, SYNCO and ADJ. SGND and PGND are star connected within the regulator package.
PGND	Block 2	Power ground: V _{IN} and V _{OUT} power returns.
VIN	Block 3	Input voltage: and sense for UVLO, OVLO and feed forward ramp.
VOUT	Block 5	Output voltage: and sense for power switches and feed-forward ramp.
VS1	Block 4	Switching node: and ZVS sense for power switches.
PGD	A1	Parallel Good: Used for parallel timing management intended for lead regulator.
EAO	A2	Error amp output: External connection for additional compensation and current sharing.
EN	A3	Enable Input: Regulator enable control. Asserted high or left floating – regulator enabled; Asserted low, regulator output disabled.
REM	A5	Remote Sense: High side connection. Connect to output regulation point.
ADJ	B1	Adjust input: An external resistor may be connected between ADJ pin and SGND or V _{OUT} to trim the output voltage up or down.
TRK	C1	Soft-start and track input: An external capacitor may be connected between TRK pin and SGND to decrease the rate of rise during soft-start.
NC	K3, A4	No Connect: Leave pins floating.
SYNCO	K4	Synchronization output: Outputs a high signal for ½ of the minimum period for synchronization of other regulators.
SYNCI	K5	Synchronization input: Synchronize to the falling edge of external clock frequency. SYNCI is a high impedance digital input node and should always be connected to SGND when not in use.
SDA	D1	Data Line: Connect to SGND. Factory use only. Not for use in application.
SCL	E1	Clock Line: Connect to SGND. Factory use only. Not for use in application.
ADR1	H1	Tri-state Address: No connect. Factory use only. Not for use in application.
ADR0	G1	Tri-state Address: No connect. Factory use only. Not for use in application.

Package Pin-Out

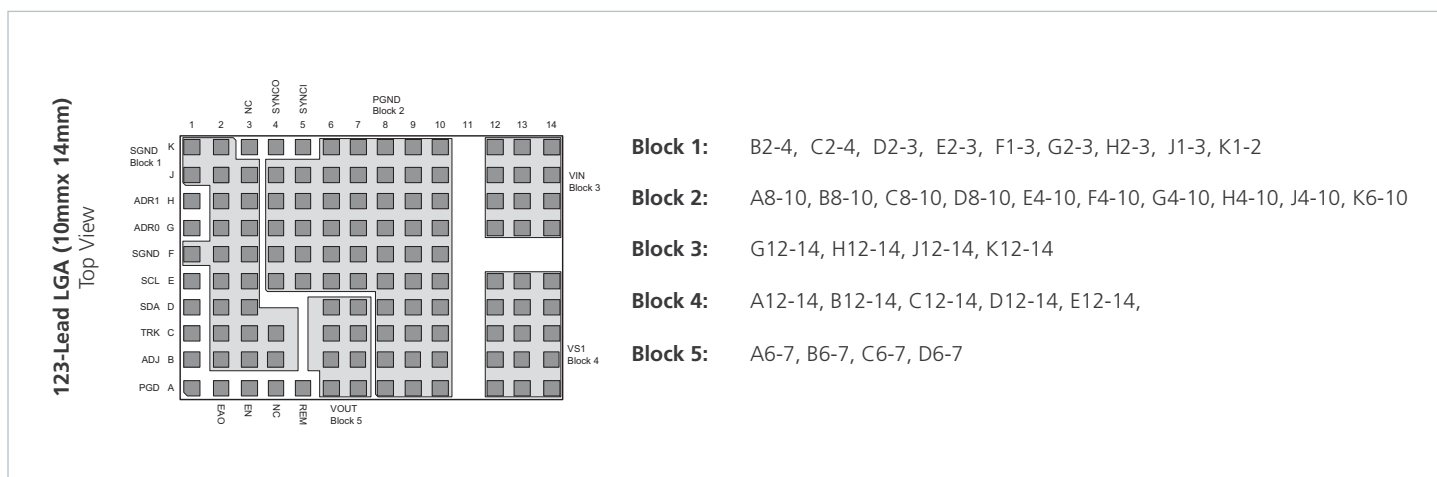

PI3420-00-LGIZ (1.0 V_{OUT}) Electrical Characteristics

Specifications apply for $-40^{\circ}\text{C} < T_J < 125^{\circ}\text{C}$, $V_{IN} = 12\text{ V}$, $L_1 = 85\text{ nH}$ (Note 1) unless other conditions are noted.

Parameter	Symbol	Conditions	Min	Typ	Max	Unit
Input Specifications						
Input Voltage	V_{IN_DC}	Minimum 1 mA load required	8	12	18	V
Input Current	I_{IN_DC}	$V_{IN} = 12\text{ V}$, $T_C = 25^{\circ}\text{C}$, $I_{OUT} = 15\text{ A}$		1.437		A
Input Current At Output Short (fault condition duty cycle)	I_{IN_Short}	Note [2]			10	mA
Input Quiescent Current	I_{Q_VIN}	Disabled		2.6		mA
		Enabled (no load)		4		
Input Voltage Slew Rate	V_{IN_SR}	Note [2]			1	V/ μs
Output Specifications						
Output Voltage Total Regulation	V_{OUT_DC}	Note [2]	0.987	1.0	1.013	V
Output Voltage Trim Range	V_{OUT_DC}	Note [3]	1.0		1.4	V
Line Regulation	$\Delta V_{OUT}(\Delta V_{IN})$	@25°C, $8\text{ V} < V_{IN} < 18\text{ V}$		0.10		%
Load Regulation	$\Delta V_{OUT}(\Delta I_{OUT})$	@25°C, $0.5\text{ A} < I_{OUT} < 15\text{ A}$		0.20		%
Output Voltage Ripple	V_{OUT_AC}	$I_{OUT} = 7.5\text{ A}$, $C_{OUT} = 8 \times 100\mu\text{F}$, 20 MHz BW, Note [4]		27		mVp-p
Continuous Output Current Range	I_{OUT_DC}		0.001		15	A
Current Limit	I_{OUT_CL}			18		A
Protection						
UVLO Start Threshold	V_{UVLO_START}		7.20	7.60	8.00	V
UVLO Stop Hysteresis	V_{UVLO_HYS}		4	5	6	V
UVLO Stop Threshold	V_{OVLO}		19.71	20.75	21.78	V
OVLO Start Hysteresis	V_{OVLO_HYS}		1.56	1.83	2.1	V
UVLO/OVLO Fault Delay Time	t_{f_DLY}	Number of the switching frequency cycles		128		Cycles
UVLO/OVLO Response Time	t_f	+1% overdrive		500		ns
Output Overvoltage Protection	V_{OVP}	Above Set V_{OUT}		20		%
Over-Temperature Fault Threshold	T_{OTP}		130	135	140	°C
Over-Temperature Restart Hysteresis	T_{OTP_HYS}			30		°C

[1] All parameters reflect regulator and inductor system performance. Measurements were made using a standard PI34xx-00 evaluation board with 3 x 4" dimensions and 4 layer, 2oz copper. Refer to inductor pairing table within Application Description section for specific inductor manufacturer and value.

[2] Regulator is assured to meet performance specifications by design, test correlation, characterization, and/or statistical process control.

[3] Output current capability may be limited and other performance may vary from noted electrical characteristics when switching frequency or V_{OUT} is modified.

[4] Refer to Output Ripple plots.

[5] Refer to Load Current vs. Ambient Temperature curves.

[6] Refer to Switching Frequency vs. Load current curves.

PI3420-00-LGIZ (1.0 V_{OUT}) Electrical Characteristics

Specifications apply for $-40^{\circ}\text{C} < T_J < 125^{\circ}\text{C}$, $V_{IN} = 12\text{ V}$, $L1 = 85\text{ nH}$ (Note 1) unless other conditions are noted.

Parameter	Symbol	Conditions	Min	Typ	Max	Unit
Timing						
Switching Frequency	f_S	Note [6]		600		kHz
Fault Restart Delay	t_{FR_DLY}			30		ms
Sync In (SYNCI)						
Synchronization Frequency Range	Δf_{SYNCI}	Relative to set switching frequency. Note [3]	50		110	%
SYNCI Threshold	V_{SYNCI}			2.5		V
Sync Out (SYNCO)						
SYNCO High	V_{SYNCO_HI}	Source 1mA	4.5			V
SYNCO Low	V_{SYNCO_LO}	Sink 1mA			0.5	V
SYNCO Rise Time	t_{SYNCO_RT}	20pF load		10		ns
SYNCO Fall Time	t_{SYNCO_FT}	20pF load		10		ns
Soft Start And Tracking						
TRK Active Input Range	V_{TRK}	Internal reference tracking range.	0		1.2	V
TRK Max Output Voltage	V_{TRK_MAX}			1.2		V
TRK Disable Threshold	V_{TRK_OV}		20	40	60	mV
Charge Current (Soft-Start)	I_{TRK}		-70	-50	-30	μA
Discharge Current (Fault)	I_{TRK_DIS}			6.8		mA
Soft-Start Time	t_{SS}	$C_{TRK} = 0\mu\text{F}$		2.2		ms
Enable						
High Threshold	V_{EN_HI}		0.9	1	1.1	V
Low Threshold	V_{EN_LO}		0.7	0.8	0.9	V
Threshold Hysteresis	V_{EN_HYS}		100	200	300	mV
Enable Pull-Up Voltage (floating, unfaulded)	V_{EN_PU}	With positive logic EN polarity		2		V
Enable Pull-Down Voltage (floating, faulted)	V_{EN_PD}	With negative logic EN polarity		0		V
Source Current	I_{EN_SO}	With positive logic EN polarity		-50		μA
Sink Current	I_{EN_SK}	With negative logic EN polarity		0		μA

[1] All parameters reflect regulator and inductor system performance. Measurements were made using a standard PI34xx-00 evaluation board with 3 x 4" dimensions and 4 layer, 2oz copper. Refer to inductor pairing table within Application Description section for specific inductor manufacturer and value.

[2] Regulator is assured to meet performance specifications by design, test correlation, characterization, and/or statistical process control.

[3] Output current capability may be limited and other performance may vary from noted electrical characteristics when switching frequency or V_{OUT} is modified.

[4] Refer to Output Ripple plots.

[5] Refer to Load Current vs. Ambient Temperature curves.

[6] Refer to Switching Frequency vs. Load current curves.

PI3420-00-LGIZ (1.0 V_{OUT}) Electrical Characteristics

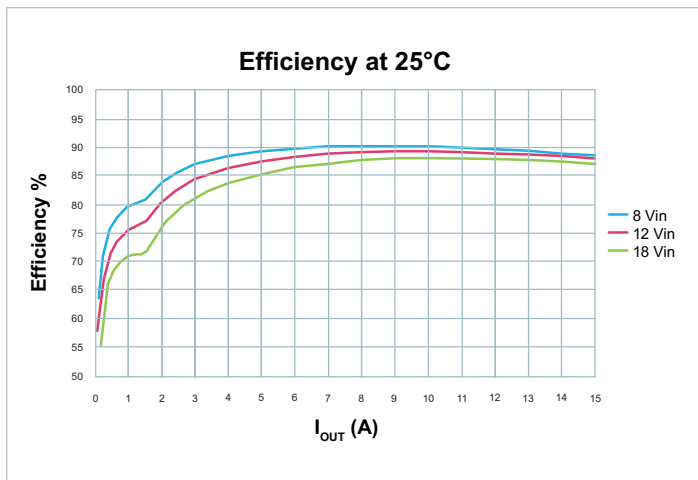

Figure 1 — Regulator and inductor performance

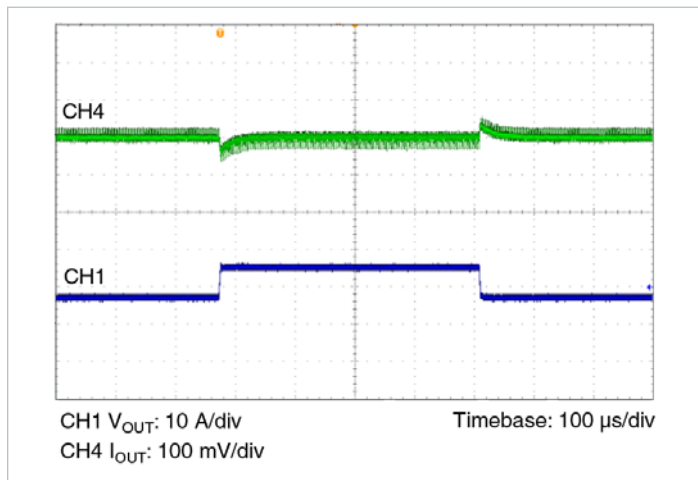

Figure 4 — 12 V_{IN} to 1.0 V_{OUT}, C_{OUT} = 8 X 100 μF Ceramic
V_{OUT} (Ch4) = 100 mV/div, I_{OUT} (Ch1) = 10 A/div, 100 μs/div

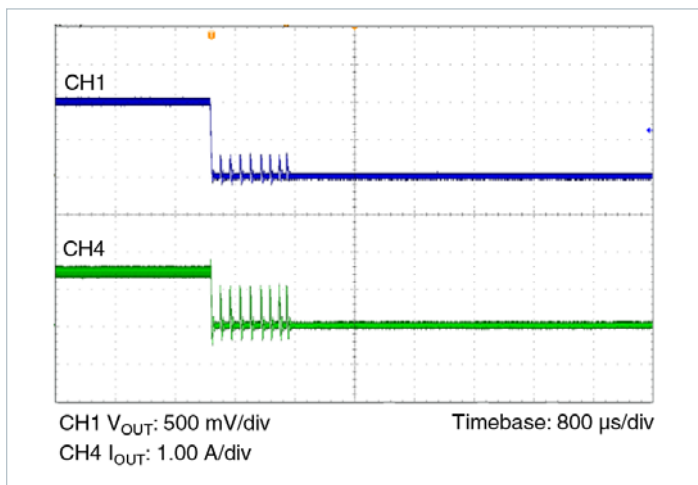

Figure 2 — V_{OUT} (Ch1) = 500 mV/div, I_{IN} (Ch4) = 1 A/div, 800 μs/div

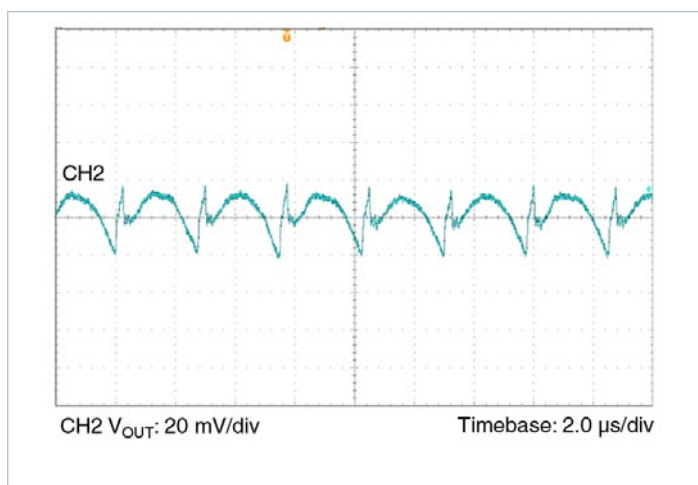

Figure 5 — Output Ripple 12 V_{IN} 1.0 V_{OUT} at 15 A; C_{OUT} = 8 x 100 μF

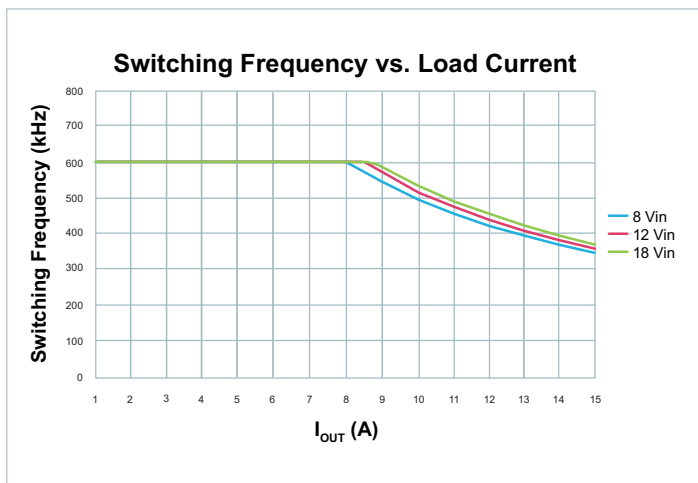

Figure 3 — Switching Frequency vs. Load Current

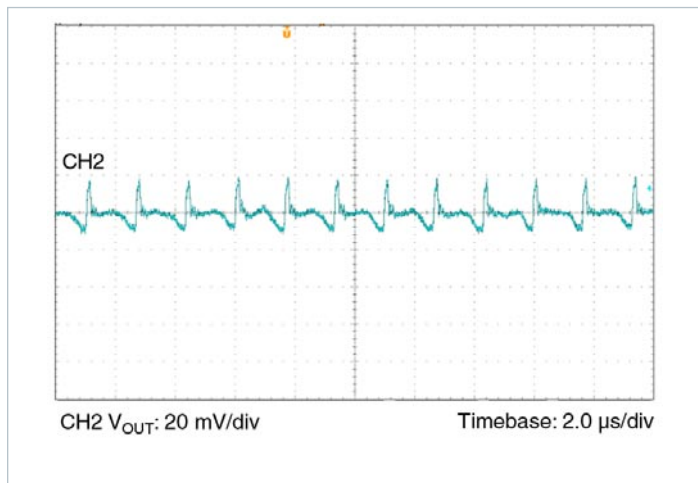

Figure 6 — Output Ripple 12 V_{IN} 1.0 V_{OUT} at 7.0 A; C_{OUT} = 8 x 100 μF

PI3421-00-LGIZ (1.8 V_{OUT}) Electrical Characteristics

Specifications apply for $-40^{\circ}\text{C} < T_J < 125^{\circ}\text{C}$, $V_{IN} = 12\text{ V}$, $L1 = 125\text{ nH}$ (Note 1) unless other conditions are noted.

Parameter	Symbol	Conditions	Min	Typ	Max	Unit
Input Specifications						
Input Voltage	V_{IN_DC}	Minimum 1 mA load required	8	12	18	V
Input Current	I_{IN_DC}	$V_{IN} = 12\text{ V}$, $T_C = 25^{\circ}\text{C}$, $I_{OUT} = 15\text{ A}$		2.46		A
Input Current At Output Short (fault condition duty cycle)	I_{IN_Short}	Note [2]			10	mA
Input Quiescent Current	I_{Q_VIN}	Disabled		2.6		mA
		Enabled (no load)		4.3		
Input Voltage Slew Rate	V_{IN_SR}	Note [2]			1	V/ μs
Output Specifications						
Output Voltage Total Regulation	V_{OUT_DC}	Note [2]	1.776	1.8	1.823	V
Output Voltage Trim Range	V_{OUT_DC}	Note [3]	1.4	1.8	2.0	V
Line Regulation	$\Delta V_{OUT}(\Delta V_{IN})$	@25 $^{\circ}\text{C}$, $8\text{ V} < V_{IN} < 18\text{ V}$		0.10		%
Load Regulation	$\Delta V_{OUT}(\Delta I_{OUT})$	@25 $^{\circ}\text{C}$, $0.5\text{ A} < I_{OUT} < 15\text{ A}$		0.20		%
Output Voltage Ripple	V_{OUT_AC}	$I_{OUT} = 7.5\text{ A}$, $C_{OUT} = 8 \times 100\mu\text{F}$, 20 MHz BW, Note [4]		20.2		mVp-p
Continuous Output Current Range	I_{OUT_DC}				15	A
Current Limit	I_{OUT_CL}			18		A
Protection						
UVLO Start Threshold	V_{UVLO_START}		7.20	7.60	8.00	V
UVLO Stop Hysteresis	V_{UVLO_HYS}		4	5	6	V
UVLO Stop Threshold	V_{OVLO}		19.71	20.75	21.78	V
OVLO Start Hysteresis	V_{OVLO_HYS}		1.56	1.83	2.1	V
UVLO/OVLO Fault Delay Time	t_{f_DLY}	Number of the switching frequency cycles		128		Cycles
UVLO/OVLO Response Time	t_f	+1% overdrive		500		ns
Output Overvoltage Protection	V_{OVP}	Above Set V_{OUT}		20		%
Over-Temperature Fault Threshold	T_{OTP}		130	135	140	$^{\circ}\text{C}$
Over-Temperature Restart Hysteresis	T_{OTP_HYS}			30		$^{\circ}\text{C}$

[1] All parameters reflect regulator and inductor system performance. Measurements were made using a standard PI34xx-00 evaluation board with 3 x 4" dimensions and 4 layer, 2oz copper. Refer to inductor pairing table within Application Description section for specific inductor manufacturer and value.

[2] Regulator is assured to meet performance specifications by design, test correlation, characterization, and/or statistical process control.

[3] Output current capability may be limited and other performance may vary from noted electrical characteristics when switching frequency or V_{OUT} is modified.

[4] Refer to Output Ripple plots.

[5] Refer to Load Current vs. Ambient Temperature curves.

[6] Refer to Switching Frequency vs. Load current curves.

PI3421-00-LGIZ (1.8 V_{OUT}) Electrical Characteristics

Specifications apply for $-40^{\circ}\text{C} < T_J < 125^{\circ}\text{C}$, $V_{IN} = 12\text{ V}$, $L1 = 125\text{ nH}$ (Note 1) unless other conditions are noted.

Parameter	Symbol	Conditions	Min	Typ	Max	Unit
Timing						
Switching Frequency	f_S	Note [6]		550		kHz
Fault Restart Delay	t_{FR_DLY}			30		ms
Sync In (SYNCI)						
Synchronization Frequency Range	Δf_{SYNCI}	Relative to set switching frequency. Note [3]	50		110	%
SYNCI Threshold	V_{SYNCI}			2.5		V
Sync Out (SYNCO)						
SYNCO High	V_{SYNCO_HI}	Source 1mA	4.5			V
SYNCO Low	V_{SYNCO_LO}	Sink 1mA			0.5	V
SYNCO Rise Time	t_{SYNCO_RT}	20pF load		10		ns
SYNCO Fall Time	t_{SYNCO_FT}	20pF load		10		ns
Soft Start And Tracking						
TRK Active Input Range	V_{TRK}	Internal reference tracking range.	0		1.2	V
TRK Max Output Voltage	V_{TRK_MAX}			1.2		V
TRK Disable Threshold	V_{TRK_OV}		20	40	60	mV
Charge Current (Soft-Start)	I_{TRK}		-70	-50	-30	μA
Discharge Current (Fault)	I_{TRK_DIS}			6.8		mA
Soft-Start Time	t_{SS}	$C_{TRK} = 0\mu\text{F}$		2.2		ms
Enable						
High Threshold	V_{EN_HI}		0.9	1	1.1	V
Low Threshold	V_{EN_LO}		0.7	0.8	0.9	V
Threshold Hysteresis	V_{EN_HYS}		100	200	300	mV
Enable Pull-Up Voltage (floating, unfaul- ted)	V_{EN_PU}	With positive logic EN polarity		2		V
Enable Pull-Down Voltage (floating, faulted)	V_{EN_PD}	With negative logic EN polarity		0		V
Source Current	I_{EN_SO}	With positive logic EN polarity		-50		μA
Sink Current	I_{EN_SK}	With negative logic EN polarity		50		μA

[1] All parameters reflect regulator and inductor system performance. Measurements were made using a standard PI34xx-00 evaluation board with 3 x 4" dimensions and 4 layer, 2oz copper. Refer to inductor pairing table within Application Description section for specific inductor manufacturer and value.

[2] Regulator is assured to meet performance specifications by design, test correlation, characterization, and/or statistical process control.

[3] Output current capability may be limited and other performance may vary from noted electrical characteristics when switching frequency or V_{OUT} is modified.

[4] Refer to Output Ripple plots.

[5] Refer to Load Current vs. Ambient Temperature curves.

[6] Refer to Switching Frequency vs. Load current curves.

PI3421-00-LGIZ (1.8 V_{OUT}) Electrical Characteristics

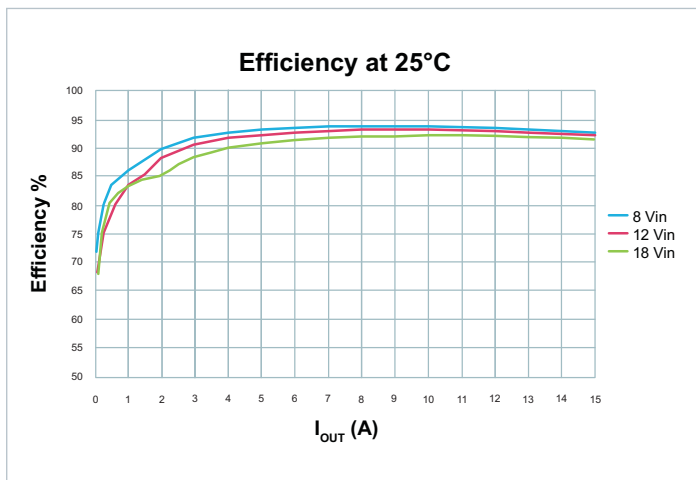

Figure 7 — Regulator and inductor performance

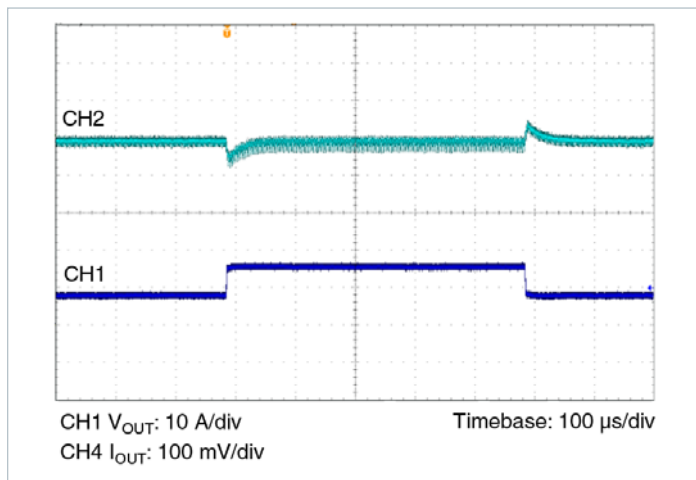

Figure 10 — 12 V_{IN} to 1.8 V_{OUT}, C_{OUT} = 8 X 100 μF Ceramic
V_{OUT} (Ch2) = 100 mV/div, I_{IN} (Ch1) = 10 A/div, 100 μs/div

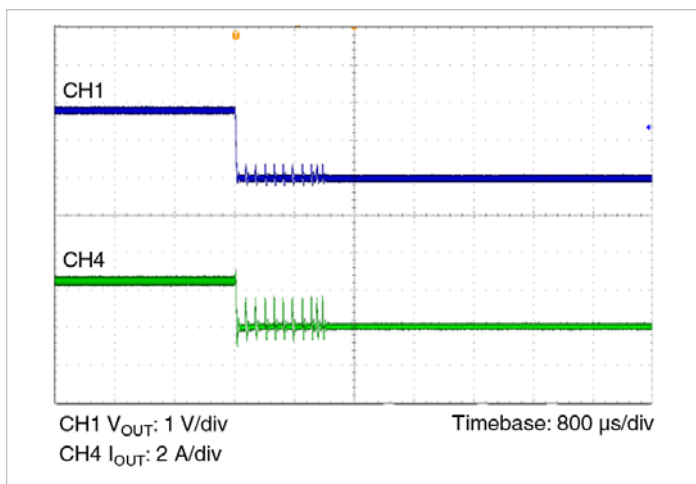

Figure 8 — V_{OUT} (Ch1) = 1V/div, I_{IN} (Ch4) = 2 A/div, 800 μs/div

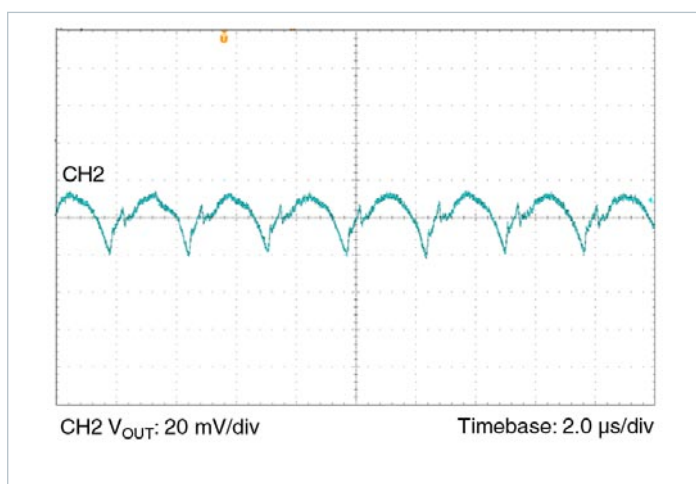

Figure 11 — Output Ripple 12 V_{IN} 1.8 V_{OUT} at 15 A; C_{OUT} = 8 x 100 μF

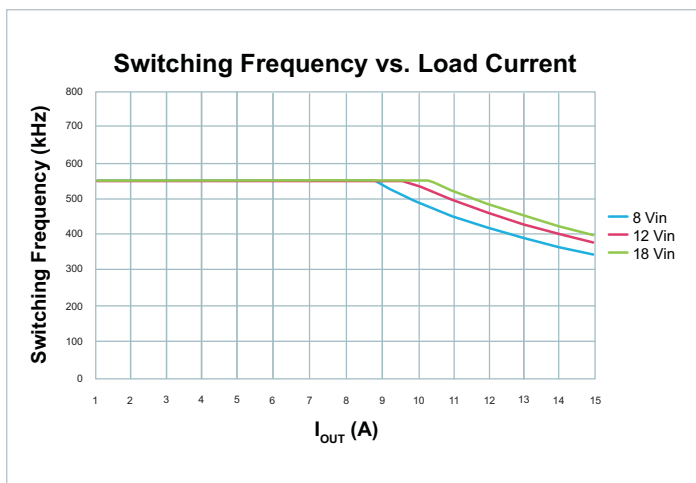

Figure 9 — Switching Frequency vs. Load Current

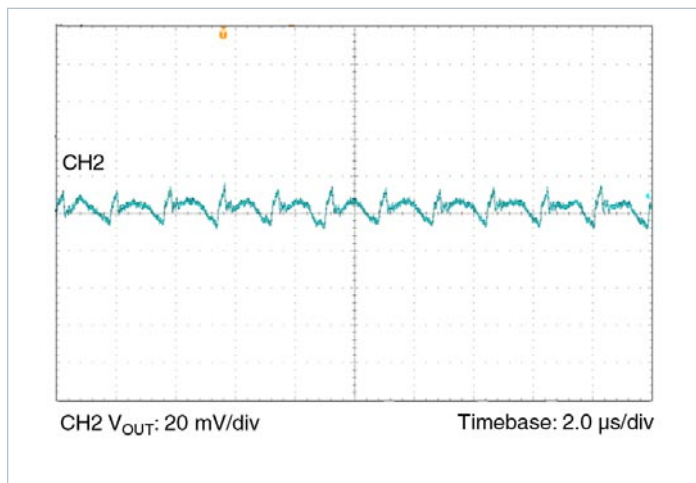

Figure 12 — Output Ripple 12 V_{IN} 1.8 V_{OUT} at 7.0 A; C_{OUT} = 8 x 100 μF

PI3422-00-LGIZ (2.5 V_{OUT}) Electrical Characteristics

Specifications apply for $-40^{\circ}\text{C} < T_J < 125^{\circ}\text{C}$, $V_{IN} = 12\text{ V}$, $L_1 = 125\text{ nH}$ (Note 1) unless other conditions are noted.

Parameter	Symbol	Conditions	Min	Typ	Max	Unit
Input Specifications						
Input Voltage	V_{IN_DC}	Minimum 1 mA load required	8	12	18	V
Input Current	I_{IN_DC}	$V_{IN} = 12\text{ V}$, $T_C = 25^{\circ}\text{C}$, $I_{OUT} = 15\text{ A}$		3.37		A
Input Current At Output Short (fault condition duty cycle)	I_{IN_Short}	Note [2]			10	mA
Input Quiescent Current	I_{Q_VIN}	Disabled		2.6		mA
		Enabled (no load)		4.0		
Input Voltage Slew Rate	V_{IN_SR}	Note [2]			1	V/ μs
Output Specifications						
Output Voltage Total Regulation	V_{OUT_DC}	Note [2]	2.465	2.5	2.535	V
Output Voltage Trim Range	V_{OUT_DC}	Note [3]	2.0	2.5	3.1	V
Line Regulation	$\Delta V_{OUT}(\Delta V_{IN})$	@25°C, 8 V < V_{IN} < 18 V		0.10		%
Load Regulation	$\Delta V_{OUT}(\Delta I_{OUT})$	@25°C, 0.5 A < I_{OUT} < 15 A		0.20		%
Output Voltage Ripple	V_{OUT_AC}	$I_{OUT} = 7.5\text{ A}$, $C_{OUT} = 8 \times 100\mu\text{F}$, 20 MHz BW, Note [4]		14		mVp-p
Continuous Output Current Range	I_{OUT_DC}				15	A
Current Limit	I_{OUT_CL}			18		A
Protection						
UVLO Start Threshold	V_{UVLO_START}		7.20	7.60	8.00	V
UVLO Stop Hysteresis	V_{UVLO_HYS}		4	5	6	V
UVLO Stop Threshold	V_{OVLO}		19.71	20.75	21.78	V
OVLO Start Hysteresis	V_{OVLO_HYS}		1.56	1.83	2.1	V
UVLO/OVLO Fault Delay Time	t_{f_DLY}	Number of the switching frequency cycles		128		Cycles
UVLO/OVLO Response Time	t_f	+1% overdrive		500		ns
Output Overvoltage Protection	V_{OVP}	Above Set V_{OUT}		20		%
Over-Temperature Fault Threshold	T_{OTP}		130	135	140	°C
Over-Temperature Restart Hysteresis	T_{OTP_HYS}			30		°C

[1] All parameters reflect regulator and inductor system performance. Measurements were made using a standard PI34xx-00 evaluation board with 3 x 4" dimensions and 4 layer, 2oz copper. Refer to inductor pairing table within Application Description section for specific inductor manufacturer and value.

[2] Regulator is assured to meet performance specifications by design, test correlation, characterization, and/or statistical process control.

[3] Output current capability may be limited and other performance may vary from noted electrical characteristics when switching frequency or V_{OUT} is modified.

[4] Refer to Output Ripple plots.

[5] Refer to Load Current vs. Ambient Temperature curves.

[6] Refer to Switching Frequency vs. Load current curves.

[7] Minimum 5 V between V_{in} - V_{out} must be maintained or a minimum load of 1 mA required.

PI3422-00-LGIZ (2.5 V_{OUT}) Electrical Characteristics

Specifications apply for $-40^{\circ}\text{C} < T_J < 125^{\circ}\text{C}$, $V_{IN} = 12\text{ V}$, $L1 = 125\text{ nH}$ (Note 1) unless other conditions are noted.

Parameter	Symbol	Conditions	Min	Typ	Max	Unit
Timing						
Switching Frequency	f_S	Note [6]		650		kHz
Fault Restart Delay	t_{FR_DLY}			30		ms
Sync In (SYNCI)						
Synchronization Frequency Range	Δf_{SYNCI}	Relative to set switching frequency. Note [3]	50		110	%
SYNCI Threshold	V_{SYNCI}			2.5		V
Sync Out (SYNCO)						
SYNCO High	V_{SYNCO_HI}	Source 1mA	4.5			V
SYNCO Low	V_{SYNCO_LO}	Sink 1mA			0.5	V
SYNCO Rise Time	t_{SYNCO_RT}	20pF load		10		ns
SYNCO Fall Time	t_{SYNCO_FT}	20pF load		10		ns
Soft Start And Tracking						
TRK Active Input Range	V_{TRK}	Internal reference tracking range.	0		1.2	V
TRK Max Output Voltage	V_{TRK_MAX}			1.2		V
TRK Disable Threshold	V_{TRK_OV}		20	40	60	mV
Charge Current (Soft-Start)	I_{TRK}		-70	-50	-30	μA
Discharge Current (Fault)	I_{TRK_DIS}			6.8		mA
Soft-Start Time	t_{SS}	$C_{TRK} = 0\mu\text{F}$		2.2		ms
Enable						
High Threshold	V_{EN_HI}		0.9	1	1.1	V
Low Threshold	V_{EN_LO}		0.7	0.8	0.9	V
Threshold Hysteresis	V_{EN_HYS}		100	200	300	mV
Enable Pull-Up Voltage (floating, unfaulded)	V_{EN_PU}	With positive logic EN polarity		2		V
Enable Pull-Down Voltage (floating, faulted)	V_{EN_PD}	With negative logic EN polarity		0		V
Source Current	I_{EN_SO}	With positive logic EN polarity		-50		μA
Sink Current	I_{EN_SK}	With negative logic EN polarity		50		μA

[1] All parameters reflect regulator and inductor system performance. Measurements were made using a standard PI34xx-00 evaluation board with 3 x 4" dimensions and 4 layer, 2oz copper. Refer to inductor pairing table within Application Description section for specific inductor manufacturer and value.

[2] Regulator is assured to meet performance specifications by design, test correlation, characterization, and/or statistical process control.

[3] Output current capability may be limited and other performance may vary from noted electrical characteristics when switching frequency or V_{OUT} is modified.

[4] Refer to Output Ripple plots.

[5] Refer to Load Current vs. Ambient Temperature curves.

[6] Refer to Switching Frequency vs. Load current curves.

[7] Minimum 5 V between V_{in} - V_{out} must be maintained or a minimum load of 1 mA required.

PI3422-00-LGIZ (2.5 V_{OUT}) Electrical Characteristics

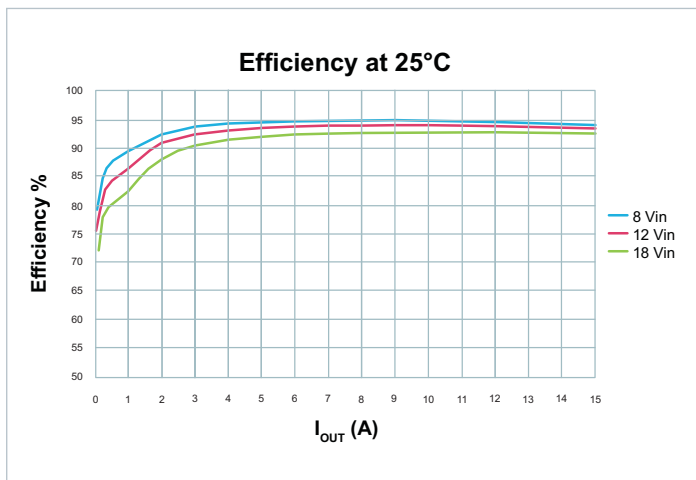

Figure 13 — Regulator and inductor performance

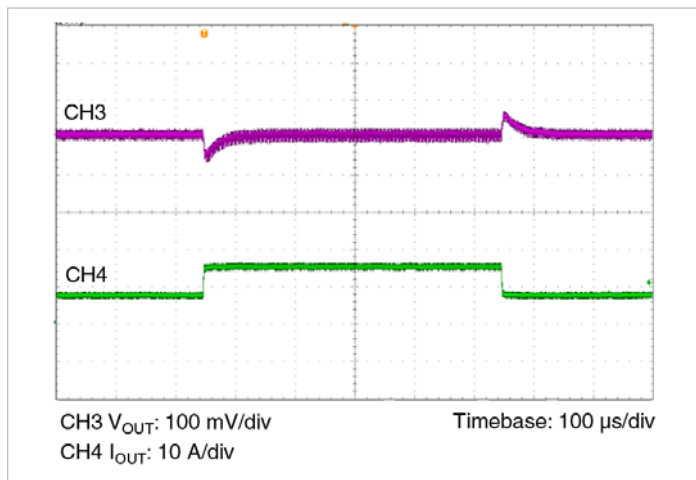

Figure 16 — 12 V_{IN} to 2.5 V_{OUT}, C_{OUT} = 8 X 100 μF Ceramic
V_{OUT} (Ch2) = 100 mV/div, I_{IN} (Ch1) = 10 A/div, 100 μs/div

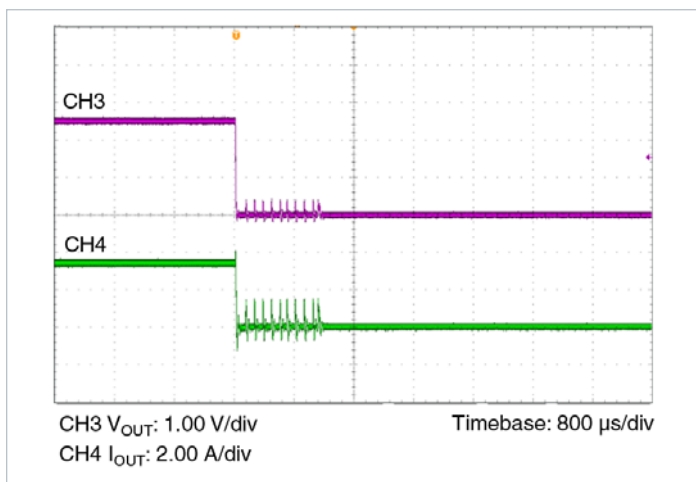

Figure 14 — V_{OUT} (Ch3) = 1V/div, I_{IN} (Ch4) = 2 A/div, 800 μs/div

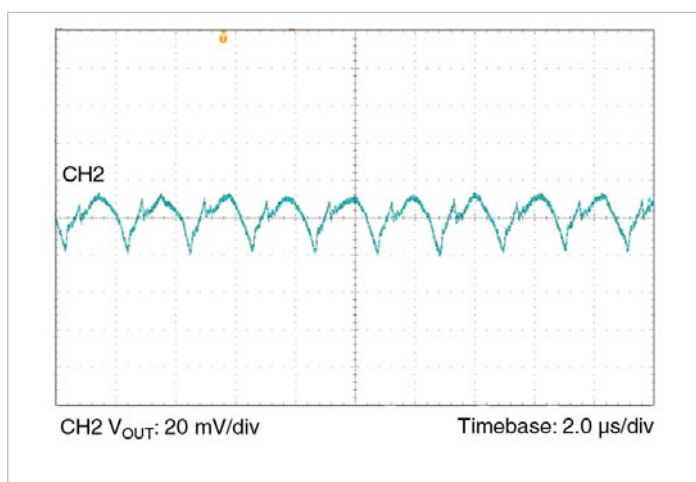

Figure 17 — Output Ripple 12 V_{IN} 2.5 V_{OUT} at 15 A; C_{OUT} = 8 x 100 μF

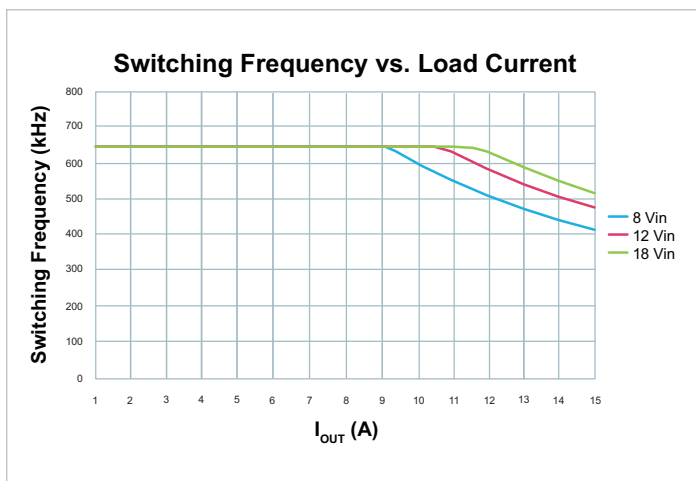

Figure 15 — Switching Frequency vs. Load Current

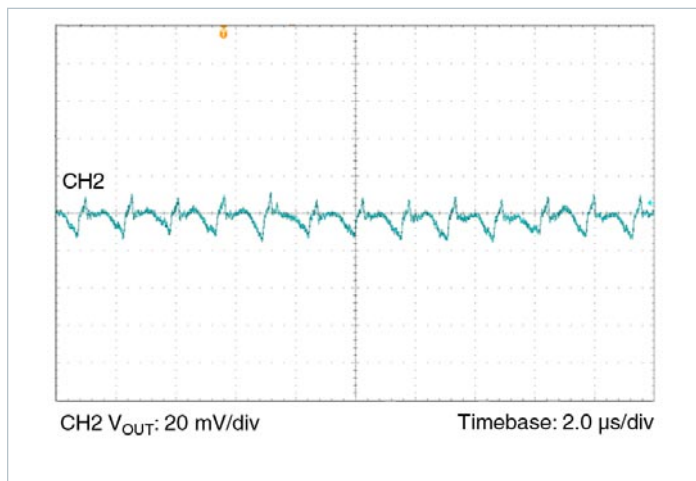

Figure 18 — Output Ripple 12 V_{IN} 2.5 V_{OUT} at 7.0 A; C_{OUT} = 8 x 100 μF

PI3423-00-LGIZ (3.3 V_{OUT}) Electrical Characteristics

Specifications apply for $-40^{\circ}\text{C} < T_J < 125^{\circ}\text{C}$, $V_{IN} = 12\text{ V}$, $L1 = 150\text{ nH}$ (Note 1) unless other conditions are noted.

Parameter	Symbol	Conditions	Min	Typ	Max	Unit
Input Specifications						
Input Voltage	V_{IN_DC}	Minimum 1 mA load required	8	12	18	V
Input Current	I_{IN_DC}	$V_{IN} = 12\text{ V}$, $T_C = 25^{\circ}\text{C}$, $I_{OUT} = 15\text{ A}$		4.43		A
Input Current At Output Short (fault condition duty cycle)	I_{IN_Short}	Note [2]			10	mA
Input Quiescent Current	I_{Q_VIN}	Disabled		2.6		mA
		Enabled (no load)		4		
Input Voltage Slew Rate	V_{IN_SR}	Note [2]			1	V/ μs
Output Specifications						
Output Voltage Total Regulation	V_{OUT_DC}	Note [2]	3.25	3.30	3.36	V
Output Voltage Trim Range	V_{OUT_DC}	Note [3]	2.3	3.3	4.1	V
Line Regulation	$\Delta V_{OUT}(\Delta V_{IN})$	@25°C, 8 V < V_{IN} < 18 V		0.10		%
Load Regulation	$\Delta V_{OUT}(\Delta I_{OUT})$	@25°C, 0.5 A < I_{OUT} < 15 A		0.10		%
Output Voltage Ripple	V_{OUT_AC}	$I_{OUT} = 7.5\text{ A}$, $C_{OUT} = 8 \times 100\mu\text{F}$, 20 MHz BW, Note [4]		17		mVp-p
Continuous Output Current Range	I_{OUT_DC}				15	A
Current Limit	I_{OUT_CL}			18		A
Protection						
UVLO Start Threshold	V_{UVLO_START}		7.20	7.60	8.00	V
UVLO Stop Hysteresis	V_{UVLO_HYS}		4	5	6	V
UVLO Stop Threshold	V_{OVLO}		19.71	20.75	21.78	V
OVLO Start Hysteresis	V_{OVLO_HYS}		1.56	1.83	2.1	V
UVLO/OVLO Fault Delay Time	t_{f_DLY}	Number of the switching frequency cycles		128		Cycles
UVLO/OVLO Response Time	t_f	+1% overdrive		500		ns
Output Overvoltage Protection	V_{OVP}	Above Set V_{OUT}		20		%
Over-Temperature Fault Threshold	T_{OTP}		130	135	140	°C
Over-Temperature Restart Hysteresis	T_{OTP_HYS}			30		°C

[1] All parameters reflect regulator and inductor system performance. Measurements were made using a standard PI34xx-00 evaluation board with 3 x 4" dimensions and 4 layer, 2oz copper. Refer to inductor pairing table within Application Description section for specific inductor manufacturer and value.

[2] Regulator is assured to meet performance specifications by design, test correlation, characterization, and/or statistical process control.

[3] Output current capability may be limited and other performance may vary from noted electrical characteristics when switching frequency or V_{OUT} is modified.

[4] Refer to Output Ripple plots.

[5] Refer to Load Current vs. Ambient Temperature curves.

[6] Refer to Switching Frequency vs. Load current curves.

[7] Minimum 5 V between V_{in} - V_{out} must be maintained or a minimum load of 1 mA required.

PI3423-00-LGIZ (3.3 V_{OUT}) Electrical Characteristics

Specifications apply for $-40^{\circ}\text{C} < T_J < 125^{\circ}\text{C}$, $V_{IN} = 12\text{ V}$, $L1 = 150\text{ nH}$ (Note 1) unless other conditions are noted.

Parameter	Symbol	Conditions	Min	Typ	Max	Unit
Timing						
Switching Frequency	f_S	Note [6]		700		kHz
Fault Restart Delay	t_{FR_DLY}			30		ms
Sync In (SYNCI)						
Synchronization Frequency Range	Δf_{SYNCI}	Relative to set switching frequency. Note [3]	50		110	%
SYNCI Threshold	V_{SYNCI}			2.5		V
Sync Out (SYNCO)						
SYNCO High	V_{SYNCO_HI}	Source 1mA	4.5			V
SYNCO Low	V_{SYNCO_LO}	Sink 1mA			0.5	V
SYNCO Rise Time	t_{SYNCO_RT}	20pF load		10		ns
SYNCO Fall Time	t_{SYNCO_FT}	20pF load		10		ns
Soft Start And Tracking						
TRK Active Input Range	V_{TRK}	Internal reference tracking range.	0		1.2	V
TRK Max Output Voltage	V_{TRK_MAX}			1.2		V
TRK Disable Threshold	V_{TRK_OV}		20	40	60	mV
Charge Current (Soft-Start)	I_{TRK}		-70	-50	-30	μA
Discharge Current (Fault)	I_{TRK_DIS}			6.8		mA
Soft-Start Time	t_{SS}	$C_{TRK} = 0\mu\text{F}$		2.2		ms
Enable						
High Threshold	V_{EN_HI}		0.9	1	1.1	V
Low Threshold	V_{EN_LO}		0.7	0.8	0.9	V
Threshold Hysteresis	V_{EN_HYS}		100	200	300	mV
Enable Pull-Up Voltage (floating, unfaul- ted)	V_{EN_PU}	With positive logic EN polarity		2		V
Enable Pull-Down Voltage (floating, faulted)	V_{EN_PD}	With negative logic EN polarity		0		V
Source Current	I_{EN_SO}	With positive logic EN polarity		-50		μA
Sink Current	I_{EN_SK}	With negative logic EN polarity		50		μA

[1] All parameters reflect regulator and inductor system performance. Measurements were made using a standard PI34xx-00 evaluation board with 3 x 4" dimensions and 4 layer, 2oz copper. Refer to inductor pairing table within Application Description section for specific inductor manufacturer and value.

[2] Regulator is assured to meet performance specifications by design, test correlation, characterization, and/or statistical process control.

[3] Output current capability may be limited and other performance may vary from noted electrical characteristics when switching frequency or V_{OUT} is modified.

[4] Refer to Output Ripple plots.

[5] Refer to Load Current vs. Ambient Temperature curves.

[6] Refer to Switching Frequency vs. Load current curves.

[7] Minimum 5 V between V_{in} - V_{out} must be maintained or a minimum load of 1 mA required.

PI3423-00-LGIZ (3.3 V_{OUT}) Electrical Characteristics

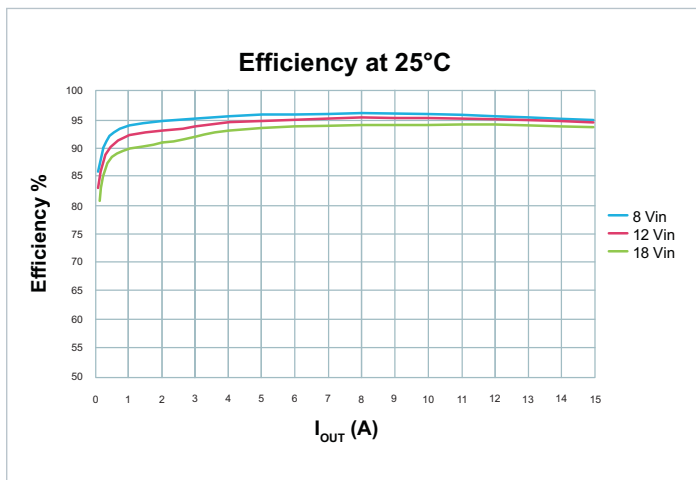

Figure 19 — Regulator and inductor performance

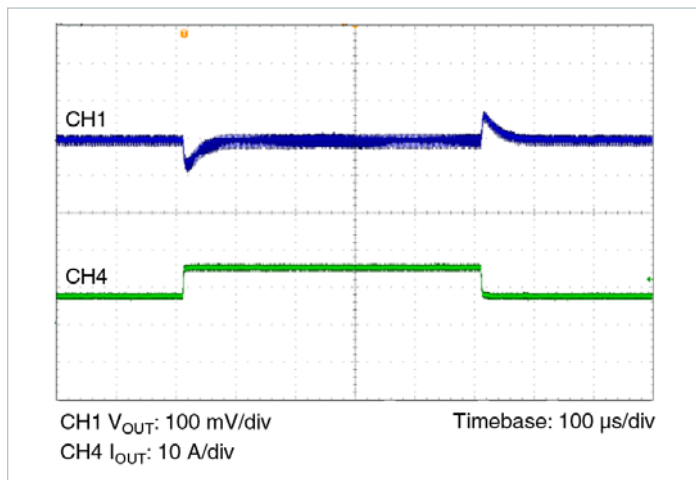

Figure 22 — 12 V_{IN} to 2.5 V_{OUT}, C_{OUT} = 8 X 100 μF Ceramic
V_{OUT} (Ch2) = 100 mV/div, I_{IN} (Ch1) = 10 A/div, 100 μs/div

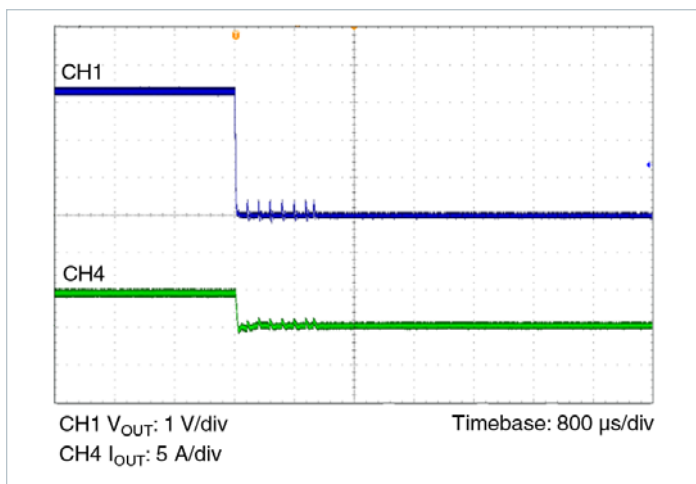

Figure 20 — V_{OUT} (Ch3) = 1 V/div, I_{IN} (Ch4) = 2 A/div, 800 μs/div

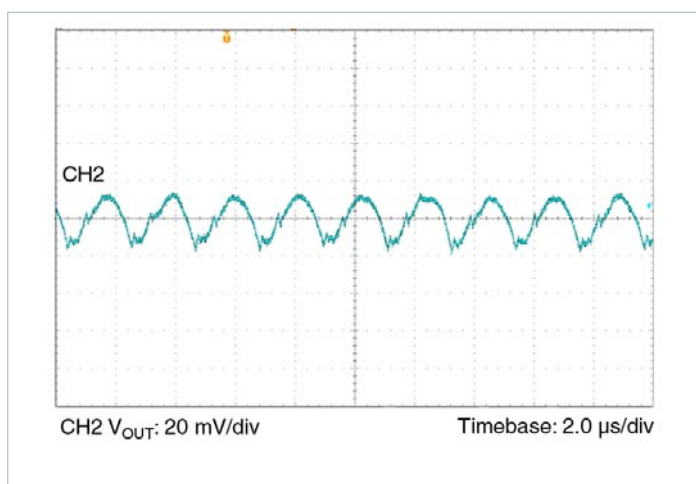

Figure 23 — Output Ripple 12 V_{IN} 3.3 V_{OUT} at 15 A; C_{OUT} = 8 x 100 μF

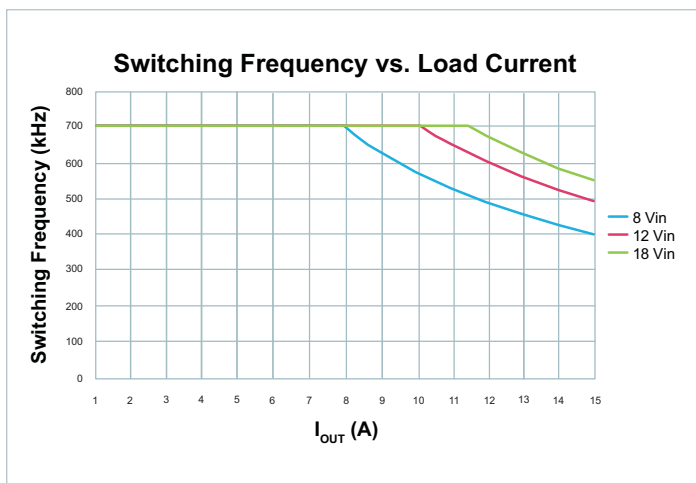

Figure 21 — Switching Frequency vs. Load Current

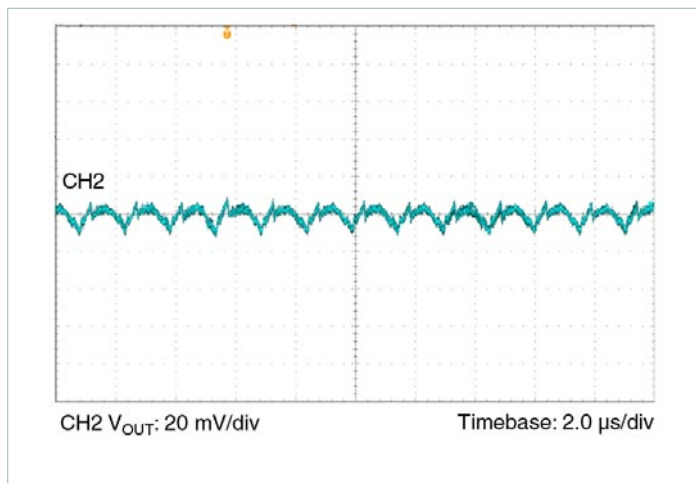

Figure 24 — Output Ripple 12 V_{IN} 3.3 V_{OUT} at 7.0 A; C_{OUT} = 8 x 100 μF

PI3424-00-LGIZ (5.0 V_{OUT}) Electrical Characteristics

Specifications apply for $-40^{\circ}\text{C} < T_J < 125^{\circ}\text{C}$, $V_{IN} = 12\text{ V}$, $L1 = 150\text{ nH}$ (Note 1) unless other conditions are noted.

Parameter	Symbol	Conditions	Min	Typ	Max	Unit
Input Specifications						
Input Voltage	V_{IN_DC}	Minimum 1 mA load required	8	12	18	V
Input Current	I_{IN_DC}	$V_{IN} = 12\text{ V}$, $T_C = 25^{\circ}\text{C}$, $I_{OUT} = 15\text{ A}$		6.57		A
Input Current At Output Short (fault condition duty cycle)	I_{IN_Short}	Note [2]			10	mA
Input Quiescent Current	I_{Q_VIN}	Disabled		2.6		mA
		Enabled (no load)		4		
Input Voltage Slew Rate	V_{IN_SR}	Note [2]			1	V/ μs
Output Specifications						
Output Voltage Total Regulation	V_{OUT_DC}	Note [2]	4.93	5	5.07	V
Output Voltage Trim Range	V_{OUT_DC}	Note [3]	3.3		6.5	V
Line Regulation	$\Delta V_{OUT}(\Delta V_{IN})$	@25 $^{\circ}\text{C}$, $8\text{ V} < V_{IN} < 18\text{ V}$		0.10		%
Load Regulation	$\Delta V_{OUT}(\Delta I_{OUT})$	@25 $^{\circ}\text{C}$, $0.5\text{ A} < I_{OUT} < 15\text{ A}$		0.10		%
Output Voltage Ripple	V_{OUT_AC}	$I_{OUT} = 7.5\text{ A}$, $C_{OUT} = 8 \times 100\mu\text{F}$, 20 MHz BW, Note [4]		20.8		mVp-p
Continuous Output Current Range	I_{OUT_DC}				15	A
Current Limit	I_{OUT_CL}			18		A
Protection						
UVLO Start Threshold	V_{UVLO_START}		7.20	7.60	8.00	V
UVLO Stop Hysteresis	V_{UVLO_HYS}		4	5	6	V
UVLO Stop Threshold	V_{OVLO}		19.71	20.75	21.78	V
OVLO Start Hysteresis	V_{OVLO_HYS}		1.56	1.83	2.1	V
UVLO/OVLO Fault Delay Time	t_{F_DLY}	Number of the switching frequency cycles		128		Cycles
UVLO/OVLO Response Time	t_f	+1% overdrive		500		ns
Output Overvoltage Protection	V_{OVP}	Above Set V_{OUT}		20		%
Over-Temperature Fault Threshold	T_{OTP}		130	135	140	$^{\circ}\text{C}$
Over-Temperature Restart Hysteresis	T_{OTP_HYS}			30		$^{\circ}\text{C}$

[1] All parameters reflect regulator and inductor system performance. Measurements were made using a standard PI34xx-00 evaluation board with 3 x 4" dimensions and 4 layer, 2oz copper. Refer to inductor pairing table within Application Description section for specific inductor manufacturer and value.

[2] Regulator is assured to meet performance specifications by design, test correlation, characterization, and/or statistical process control.

[3] Output current capability may be limited and other performance may vary from noted electrical characteristics when switching frequency or V_{OUT} is modified.

[4] Refer to Output Ripple plots.

[5] Refer to Load Current vs. Ambient Temperature curves.

[6] Refer to Switching Frequency vs. Load current curves.

[7] Minimum 5 V between V_{in} - V_{out} must be maintained or a minimum load of 1 mA required.

PI3424-00-LGIZ (5.0 V_{OUT}) Electrical Characteristics

Specifications apply for $-40^{\circ}\text{C} < T_J < 125^{\circ}\text{C}$, $V_{IN} = 12\text{ V}$, $L1 = 150\text{ nH}$ (Note 1) unless other conditions are noted.

Parameter	Symbol	Conditions	Min	Typ	Max	Unit
Timing						
Switching Frequency	f_S	Note [6]		750		kHz
Fault Restart Delay	t_{FR_DLY}			30		ms
Sync In (SYNCI)						
Synchronization Frequency Range	Δf_{SYNCI}	Relative to set switching frequency. Note [3]	50		110	%
SYNCI Threshold	V_{SYNCI}			2.5		V
Sync Out (SYNCO)						
SYNCO High	V_{SYNCO_HI}	Source 1mA	4.5			V
SYNCO Low	V_{SYNCO_LO}	Sink 1mA			0.5	V
SYNCO Rise Time	t_{SYNCO_RT}	20pF load		10		ns
SYNCO Fall Time	t_{SYNCO_FT}	20pF load		10		ns
Soft Start And Tracking						
TRK Active Input Range	V_{TRK}	Internal reference tracking range.	0		1.2	V
TRK Max Output Voltage	V_{TRK_MAX}			1.2		V
TRK Disable Threshold	V_{TRK_OV}		20	40	60	mV
Charge Current (Soft-Start)	I_{TRK}		-70	-50	-30	μA
Discharge Current (Fault)	I_{TRK_DIS}			6.8		mA
Soft-Start Time	t_{SS}	$C_{TRK} = 0\mu\text{F}$		2.2		ms
Enable						
High Threshold	V_{EN_HI}		0.9	1	1.1	V
Low Threshold	V_{EN_LO}		0.7	0.8	0.9	V
Threshold Hysteresis	V_{EN_HYS}		100	200	300	mV
Enable Pull-Up Voltage (floating, unfaul- ted)	V_{EN_PU}	With positive logic EN polarity		2		V
Enable Pull-Down Voltage (floating, faulted)	V_{EN_PD}	With negative logic EN polarity		0		V
Source Current	I_{EN_SO}	With positive logic EN polarity		-50		μA
Sink Current	I_{EN_SK}	With negative logic EN polarity		50		μA

[1] All parameters reflect regulator and inductor system performance. Measurements were made using a standard PI34xx-00 evaluation board with 3 x 4" dimensions and 4 layer, 2oz copper. Refer to inductor pairing table within Application Description section for specific inductor manufacturer and value.

[2] Regulator is assured to meet performance specifications by design, test correlation, characterization, and/or statistical process control.

[3] Output current capability may be limited and other performance may vary from noted electrical characteristics when switching frequency or V_{OUT} is modified.

[4] Refer to Output Ripple plots.

[5] Refer to Load Current vs. Ambient Temperature curves.

[6] Refer to Switching Frequency vs. Load current curves.

[7] Minimum 5 V between V_{in} - V_{out} must be maintained or a minimum load of 1 mA required.

PI3424-00-LGIZ (5.0 V_{OUT}) Electrical Characteristics

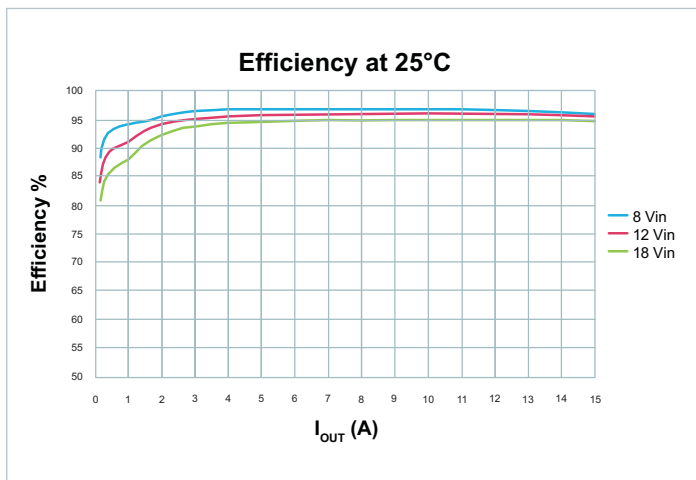

Figure 25 — Regulator and inductor performance

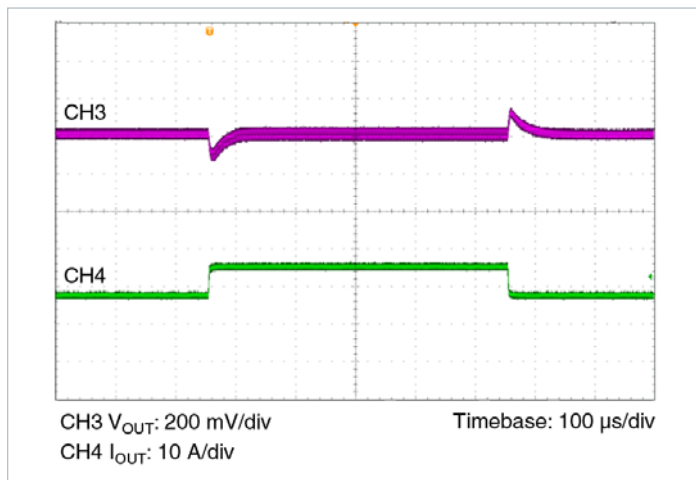

Figure 28 — 12 V_{IN} to 5.0 V_{OUT}, C_{OUT} = 8 X 47 μF Ceramic
V_{OUT} (Ch2) = 200 mV/Div, I_{OUT} (Ch1) = 10 A/Div, 100 μs/Div

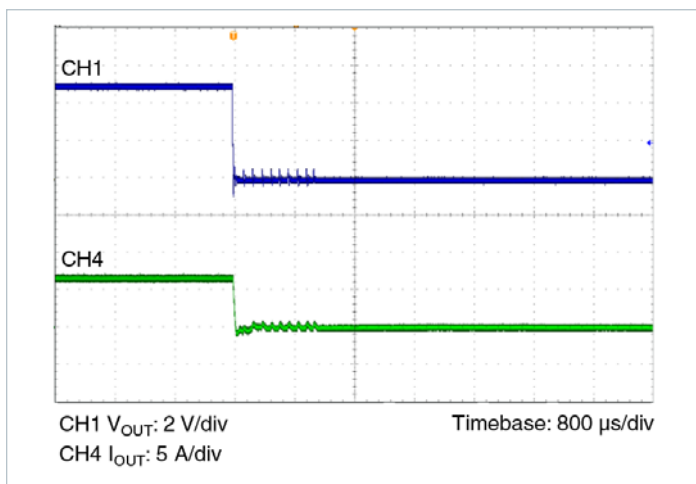

Figure 26 — V_{OUT} (Ch1) = 2 V/Div, I_{IN} (Ch4) = 5 A/Div, 800 μs/Div

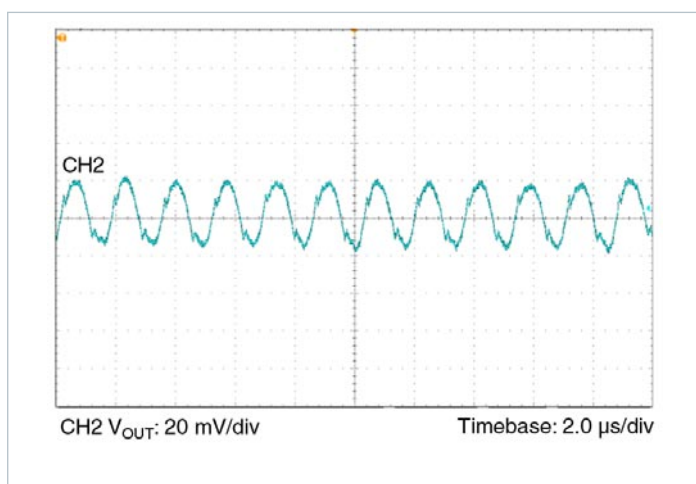

Figure 29 — Output Ripple 12 V_{IN} 5.0 V_{OUT} at 15 A; C_{OUT} = 8 x 47 μF

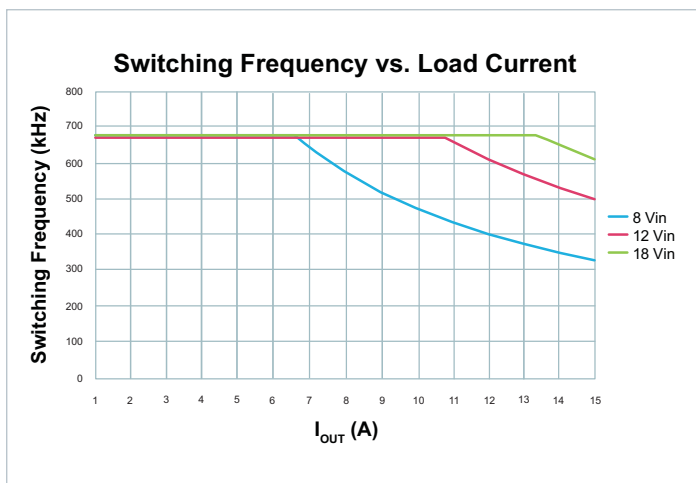

Figure 27 — Switching Frequency vs. Load Current

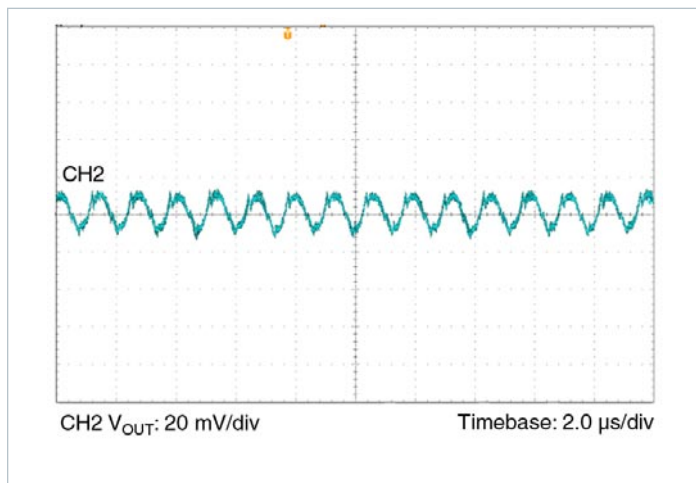

Figure 30 — Output Ripple 12 V_{IN} 5.0 V_{OUT} at 7.0 A; C_{OUT} = 8 x 47 μF

Thermal Derating Curves

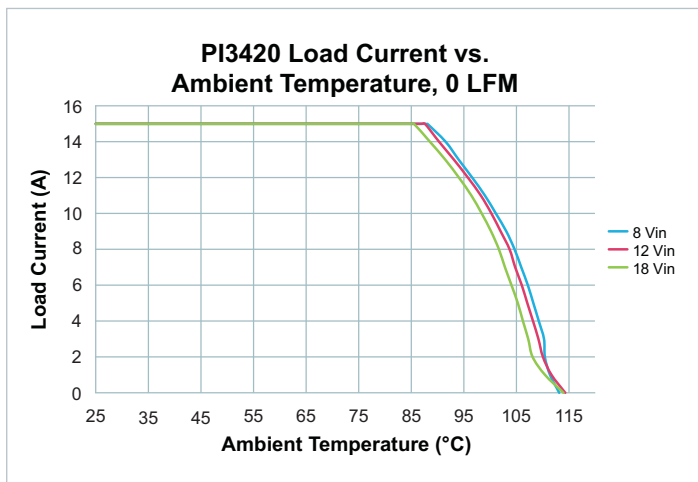

Figure 31 — PI3420 - Load Current vs. Ambient Temperature, 0 LFM

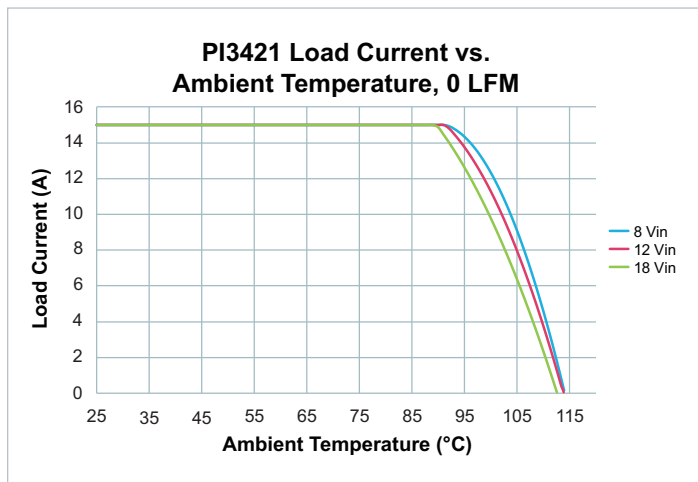

Figure 34 — PI3421 - Load Current vs. Ambient Temperature, 0 LFM

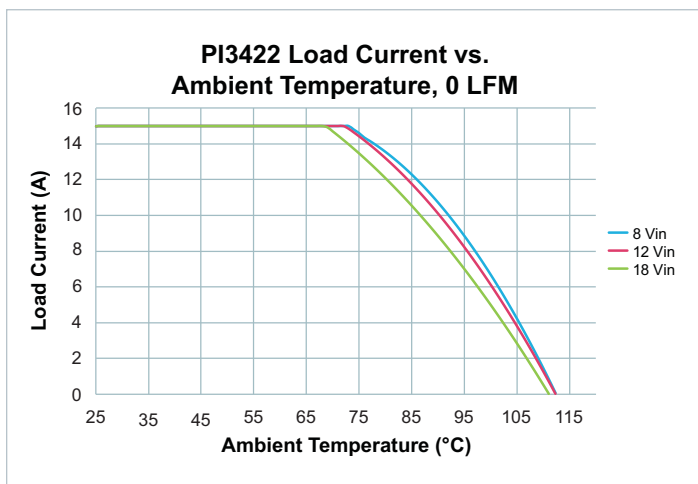

Figure 32 — PI3422 - Load Current vs. Ambient Temperature, 0 LFM

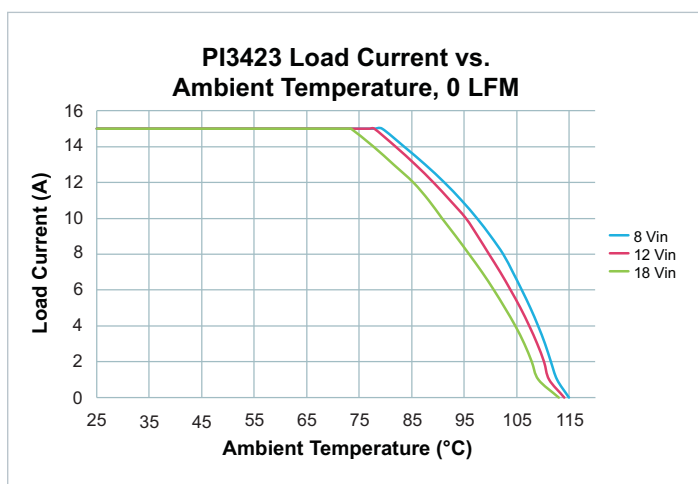

Figure 35 — PI3423 - Load Current vs. Ambient Temperature, 0 LFM

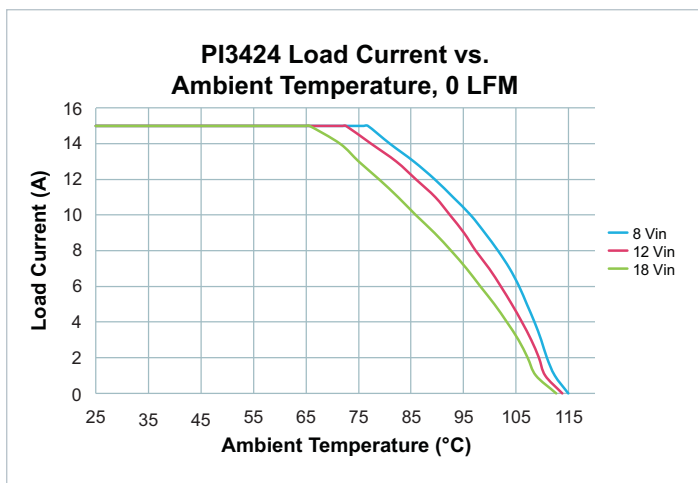

Figure 33 — PI3424 - Load Current vs. Ambient Temperature, 0 LFM

Functional Description

The PI34xx-00 is a family of highly integrated ZVS-Buck regulators. The PI34xx-00 has a set output voltage that is trimmable within a prescribed range shown in Table 1. Performance and maximum output current are characterized with a specific external power inductor (see Table 4).

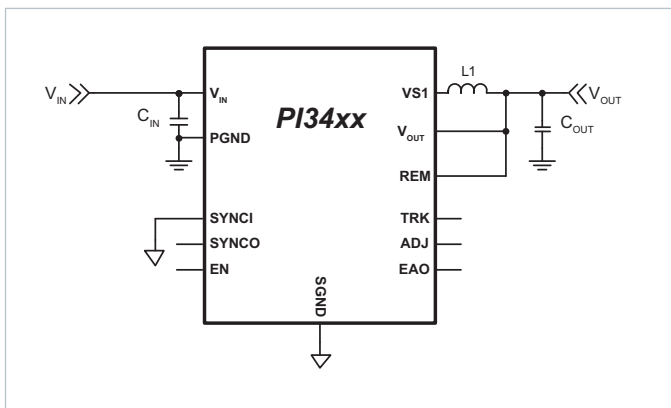

Figure 36 — ZVS-Buck with required components

For basic operation, Figure 36 shows the connections and components required. No additional design or settings are required.

ENABLE (EN)

EN is the enable pin of the regulator. The EN Pin is referenced to SGND and permits the user to turn the regulator on or off. The EN polarity is a positive logic assertion. If the EN pin is left floating or asserted high, the regulator output is enabled. Pulling EN pin below 0.8 Vdc with respect to SGND will disable the regulator output.

Remote Sensing

An internal 100 Ω resistor is connected between REM pin and VOUT pin to provide regulation when the REM connection is broken. Referring to Figure 36, it is important to note that L1 and Cout are the output filter and the local sense point for the power supply output. As such, the REM pin should be connected at Cout as the default local sense connection unless remote sensing to compensate additional distribution losses in the system. The REM pin should not be left floating.

Switching Frequency Synchronization

The SYNCI input allows the user to synchronize the controller switching frequency by an external clock referenced to SGND. The external clock can synchronize the unit between 50% and 110% of the preset switching frequency (fs).

The PI34xx-00 syncs to the falling edge of the applied clock providing 180° phase shift from SYNCO. This allows for the paralleling of two PI34xx-00 devices. When using the internal oscillator, the SYNCO pin provides a 5 V clock that can be used to sync other regulators. Therefore, one PI34xx-00 can act as the lead regulator and have additional PI34xx-00s running in parallel and interleaved.

Soft-Start

The PI34xx-00 includes an internal soft-start capacitor to ramp the output voltage in 2ms from 0 V to full output voltage. Connecting an external capacitor from the TRK pin to SGND will increase the start-up ramp period. See, “Soft Start Adjustment and Track,” in the Applications Description section for more details.

Output Voltage Trim

The PI34xx-00 output voltage can be trimmed up from the preset output by connecting a resistor from ADJ pin to SGND and can be trimmed down by connecting a resistor from ADJ pin to VOUT. The Table 1 defines the voltage ranges for the PI34xx-00 family.

Device	Output Voltage	
	Set	Range
PI3420-00-LGIZ	1.0 V	1.0 to 1.4 V
PI3421-00-LGIZ	1.8 V	1.4 to 2.0 V
PI3422-00-LGIZ	2.5 V	2.0 to 3.1 V
PI3423-00-LGIZ	3.3 V	2.3 to 4.1 V
PI3424-00-LGIZ	5.0 V	3.3 to 6.5 V

Table 1 — PI34xx-00 family output voltage ranges

Output Current Limit Protection

PI34xx-00 has two methods implemented to protect from output short or over current condition.

Slow Current Limit protection: prevents the output load from sourcing current higher than the regulator’s maximum rated current. If the output current exceeds the Current Limit (I_{OUT_CL}) for 1024 μ s, a slow current limit fault is initiated and the regulator is shutdown which eliminates output current flow. After Fault Restart Delay (t_{FR_DLY}), a soft-start cycle is initiated. This restart cycle will be repeated indefinitely until the excessive load is removed.

Fast Current Limit protection: PI34xx-00 monitors the regulator inductor current pulse-by-pulse to prevent the output from supplying very high current due to sudden low impedance short (50 A Typical). If the regulator senses a high inductor current pulse, it will initiate a fault and stop switching until Fault Restart Delay ends and then initiate a soft-start cycle.

Input Undervoltage Lockout

If V_{IN} falls below the input Undervoltage Lockout (UVLO) threshold, the regulator will enter a low power state and initiate a fault. The system will restart once the input voltage is reestablished and after the Fault Restart Delay.

Input Overvoltage Lockout

If V_{IN} exceeds the input Overvoltage Lockout (OVLO) threshold (VOVLO), while the regulator is running, the PI34xx-00 will complete the current cycle and stop switching. The system will resume operation after the Fault Restart Delay.

Output Overvoltage Protection

The PI34xx-00 family is equipped with output Overvoltage Protection (OVP) to prevent damage to input voltage sensitive devices. If the output voltage exceeds 20% of its set regulated value, the regulator will complete the current cycle, stop switching and issue an OVP fault. The system will resume operation once the output voltage falls below the OVP threshold and after Fault Restart Delay.

Overtemperature Protection

The internal package temperature is monitored to prevent internal components from reaching their thermal maximum. If the Over Temperature Protection Threshold (OTP) is exceeded (T_{OTP}), the regulator will complete the current switching cycle, enter a low power mode, set a fault flag, and will soft-start when the internal temperature falls below Over-Temperature Restart (T_{OTP_HYS}).

Parallel Operation

Paralleling modules can be used to increase the output current capability of a single power rail and reduce output voltage ripple.

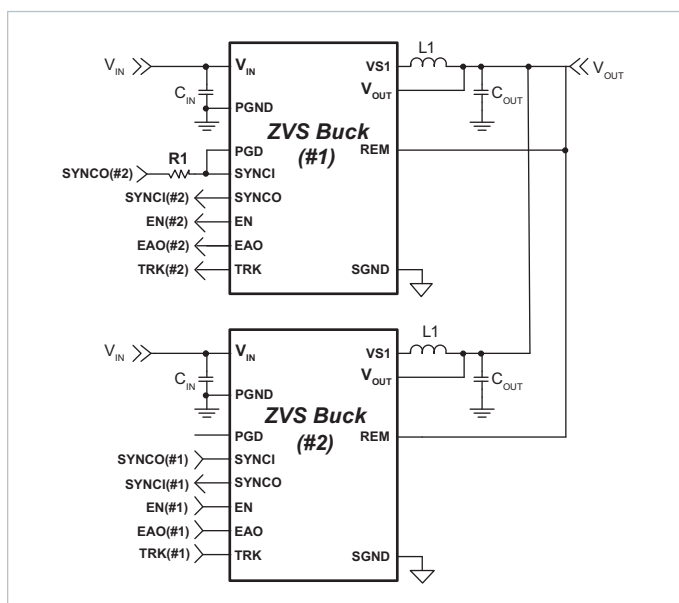

Figure 37 — PI34xx-00 parallel operation

By connecting the EAO pins and SGND pins of each module together the units will share the current equally. When the TRK pins of each unit are connected together, the units will track each other during soft-start and all unit EN pins have to be released to allow the units to start (See Figure 37). Also, any fault event in any regulator will disable the other regulators. The two regulators will be out of phase with each other reducing output ripple (refer to Switching Frequency Synchronization).

To provide synchronization between regulators over the entire operational frequency range, the Parallel Good (PGD) pin must be connected to the lead regulator's (#1) SYNCI pin and a 2.5 k Ω Resistor, R1, must be placed between SYNCO (#2) return and the lead regulator's SYNCI (#1) pin, as shown in Figure 37. In this configuration, at system soft-start, the PGD pin pulls SYNCI low forcing the lead regulator to

initialize the open-loop startup synchronization. Once the regulators reach regulation, SYNCI is released and the system is now synchronized in a closed-loop configuration which allows the system to adjust, on the fly, when any of the individual regulators begin to enter variable frequency mode in the loop.

Pulse Skip Mode (PSM)

PI34xx-00 features a PSM to achieve high efficiency at light loads. The regulators are setup to skip pulses if EAO falls below a PSM threshold. Depending on conditions and component values, this may result in single pulses or several consecutive pulses followed by skipped pulses. Skipping cycles significantly reduces gate drive power and improves light load efficiency. The regulator will leave PSM once the EAO rises above the Skip Mode threshold.

Variable Frequency Operation

Each PI34xx-00 is preprogrammed to a base operating frequency, with respect to the power stage inductor (see Table 4), to operate at peak efficiency across line and load variations. At low line and high load applications, the base frequency will decrease to accommodate these extreme operating ranges. By stretching the frequency, the ZVS operation is preserved throughout the total input line voltage range therefore maintaining optimum efficiency.

Application Description

Output Voltage Trim

The PI34xx-00 family of Buck Regulators provides five common output voltages: 1.0 V, 1.8 V, 2.5 V, 3.3 V and 5.0 V. A post-package trim step is implemented to offset any resistor divider network errors ensuring maximum output accuracy. With a single resistor connected from the ADJ pin to SGND or REM, each device's output can be varied above or below the nominal set voltage (the PI3420-00 can only be adjusted above the set voltage of 1 V).

Device	Output Voltage	
	Set	Range
PI3420-00-LGIZ	1.0 V	1.0 to 1.4 V
PI3421-00-LGIZ	1.8 V	1.4 to 2.0 V
PI3422-00-LGIZ	2.5 V	2.0 to 3.1 V
PI3423-00-LGIZ	3.3 V	2.3 to 4.1 V
PI3424-00-LGIZ	5.0 V	3.3 to 6.5 V

Table 2 — PI34xx-00 family output voltage ranges

The remote pin (REM) should always be connected to the V_{OUT} pin to prevent an output voltage offset. Figure 38 shows the internal feedback voltage divider network.

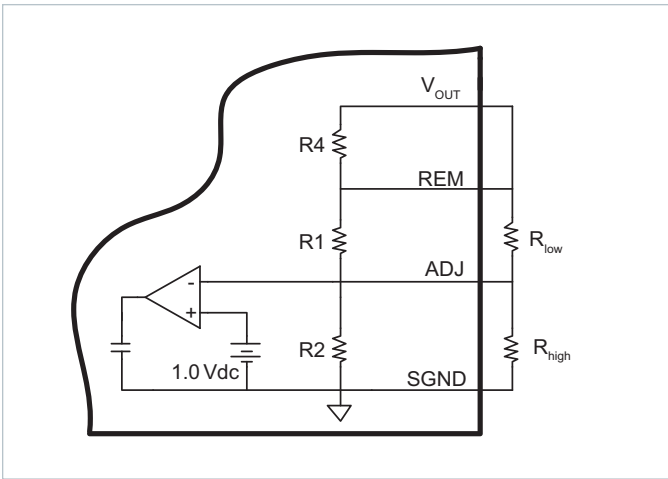

Figure 38 — Internal resistor divider network

R1, R2, and R4 are all internal 1.0 % resistors and R_low and R_high are external resistors for which the designer can add to modify V_OUT to a desired output. The internal resistor values for each regulator are listed next in Table 3.

Device	R1	R2	R4
PI3420-00-LGIZ	1 k	∞	100
PI3421-00-LGIZ	0.806 k	1.0 k	100
PI3422-00-LGIZ	1.5 k	1.0 k	100
PI3423-00-LGIZ	2.61 k	1.13 k	100
PI3424-00-LGIZ	4.53 k	1.13 k	100

Table 3 — PI34xx-00 Internal divider values

By choosing an output voltage value within the ranges stated in Table 2, V_OUT can simply be adjusted up or down by selecting the proper R_high or R_low value, respectively. The following equations can be used to calculate R_high and R_low values:

$$R_{high} = \frac{1}{\frac{(V_{out} - 1)}{R1} - \left(\frac{1}{R2}\right)} \quad (1)$$

$$R_{low} = \frac{1}{\frac{1}{R2(V_{out} - 1)} - \left(\frac{1}{R1}\right)} \quad (2)$$

If, for example, a 4.0 V output is needed, the user should choose the regulator with a trim range covering 4.0 V from Table 2. For this example, the PI3423 is selected (3.3 V set voltage). First step would be to use Equation (1) to calculate R_HIGH since the required output voltage is higher than the regulator set voltage. The resistor-divider network values for the PI3423 can be found in Table 3 and are R1 = 2.61k Ω and R2 = 1.13 kΩ. Inserting these values in to Equation (1), R_HIGH is calculated as follows:

$$3.78k = \frac{1}{\frac{(4.0 - 1)}{2.61k} - \left(\frac{1}{1.13k}\right)}$$

Resistor R_high should be connected as shown in Figure 38 to achieve the desired 4.0 V regulator output. No external R_low resistor is need in this design example since the trim is above the regulator set voltage.

The PI3420 output voltage can only be trimmed higher than the factory 1 V setting. The following Equation (3) can be used calculate Rhigh values for the PI3420 regulators.

$$R_{high(1V)} = \frac{1}{\frac{(V_{out} = 1)}{R1}} \quad (3)$$

Soft-Start Adjust and Tracking

The TRK pin offers a means to increase the regulator’s soft-start time or to track with additional regulators. . The soft-start slope is controlled by an internal capacitor and a fixed charge current to provide a Soft-Start Time tSS for all for all PI34xx-00 regulators. By adding an additional external capacitor to the TRK pin, the soft-start time can be increased further. The following equation can be used to calculate the proper capacitor for a desired soft-start times:

$$C_{TRK} = (t_{TRK} \times I_{TRK}) - 100 \times 10^{-9},$$

where, t_TRK is the soft-start time and I_TRK is a 50 μA internal charge current (see Electrical Characteristics for limits). There is typically either a proportional or direct tracking method implemented within a tracking design. For proportional tracking between several regulators at startup, simply connect all devices TRK pins together. This type of tracking will force all connected regulators to startup and reach regulation at the same time (see Figure 39 (a)).

For Direct Tracking, choose the regulator with the highest output voltage as the master and connect the master TRK pin to the TRK pin of the other regulators through a divider (Figure 40) with the same ratio as the slave’s feedback divider (see Table 3 for values).

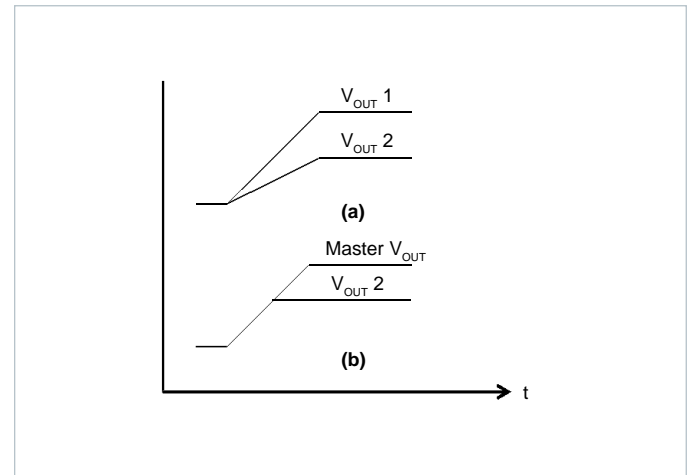

Figure 39 — PI34xx-00 tracking methods

All connected regulators’ soft-start slopes will track with this method. Direct tracking timing is demonstrated in Figure 39 (b).

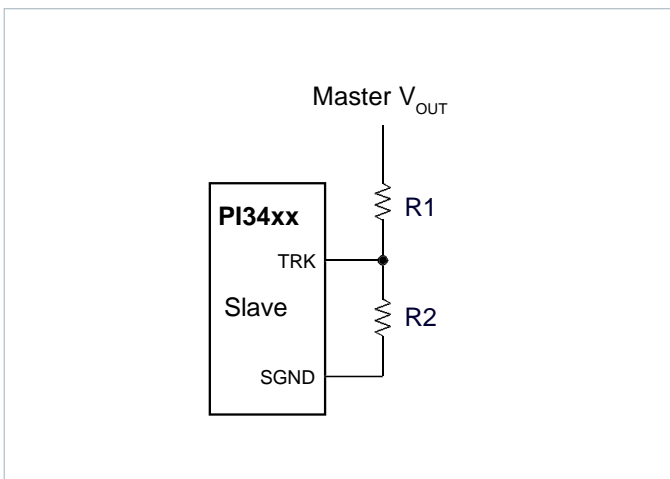

Figure 40 — Voltage divider connections for direct tracking

All tracking regulators should have their Enable (EN) pins connected together to work properly.

Inductor Pairing

The PI34xx-00 utilizes an external inductor from the Eaton Inductor line at Cooper Industries. This inductor has been optimized for maximum efficiency performance. Table 4 details the specific inductor value and part number utilized for each PI34xx-00 device. Datasheets are available at www.cooperindustries.com.

Device	Inductor [nH]	Inductor Part Number	Manufacturer
PI3420-00	85	FPV1006-85-R	Eaton
PI3421-00	125	FPV1006-125-R	Eaton
PI3422-00	125	FPV1006-125-R	Eaton
PI3423-00	150	FPV1006-150-R	Eaton
PI3424-00	150	FPV1006-150-R	Eaton

Table 4 — PI34xx-00 Inductor pairing

Thermal Derating

Thermal de-rating curves are provided that are based on component temperature changes versus load current, input voltage and air flow. It is recommended to use these curves as a guideline for proper thermal de-rating. These curves represent the entire system and are inclusive to both the Picor regulator and the external inductor. Maximum thermal operation is limited by either the MOSFETs or inductor depending upon line and load conditions.

Thermal measurements were made using a standard PI34xx-00 Evaluation board which is 3 x 4 inches in area and uses 4-layer, 2oz copper. Thermal measurements were made on the three main power devices, the two internal MOSFETs and the external inductor.

Filter Considerations

The PI34xx-00 requires input bulk storage capacitance as well as low impedance ceramic X5R input capacitors to ensure proper start up and high frequency decoupling for the power stage. The PI34xx-00 will draw nearly all of the high frequency current from the low impedance ceramic capacitors when the main high side MOSFET is conducting. During the time the high side MOSFET is off, they are replenished from the bulk capacitor. If the input impedance is high at the switching frequency of the regulator, the bulk capacitor must supply all of the average current into the regulator, including replenishing the ceramic capacitors. This value has been chosen to be 100µF so that the PI34xx-00 can start up into a full resistive load and supply the output capacitive load with the default minimum soft start capacitor when the input source impedance is 50 Ohms at 1MHz. The ESR for this capacitor should be approximately 20mΩ. The RMS ripple current in this capacitor is small, so it should not be a concern if the input recommended ceramic capacitors are used. Table 5 shows the recommended input and output capacitors to be used for the various models as well as expected transient response, RMS ripple currents per capacitor, and input and output ripple voltages. Table 6 includes the recommended input and output ceramic capacitors.

Device	V _{IN} (V)	I _{LOAD} (A)	C _{INPUT} Bulk Elec.	C _{INPUT} Ceramic X5R	C _{OUTPUT} Ceramic X5R	C _{INPUT} Ripple Current (I _{RMS})	C _{OUTPUT} Ripple Current (I _{RMS})	Input Ripple (mVpp)	Output Ripple (mVpp)	Output Ripple (mVpk)	Recovery Time (µs)	Load Step (A) (Slew/µs)																																																	
PI3420	12	15	100 µF 50 V	6 x 22 µF	8 X 100 µF 2 X 1 µF 1 X 0.1 µF	0.85	1.24	98	36	-/+41	42	7.5 (5 A/µs)																																																	
		43						27	PI3421				12	15	100 µF 50 V	6 x 22 µF	8 X 100 µF 2 X 1 µF 1 X 0.1 µF	1.0	1.18	139	32	-/+50	50	7.5 (5 A/µs)	45	20.4	PI3422	12	15	100 µF 50 V	6 x 22 µF	8 X 100 µF 2 X 1 µF 1 X 0.1 µF	1.12	1.16	145	28	-/+46	60	7.5 (5 A/µs)	74	14	PI3423	12	15	100 µF 50 V	6 x 22 µF	8 X 100 µF 2 X 1 µF 1 X 0.1 µF	1.20	1.15	179	26	-/+73	70	7.5 (5 A/µs)	97	17	PI3424	12	15	100 µF 50 V	6 x 22 µF
PI3421	12	15	100 µF 50 V	6 x 22 µF	8 X 100 µF 2 X 1 µF 1 X 0.1 µF	1.0	1.18	139		32	-/+50	50		7.5 (5 A/µs)																																															
		45						20.4	PI3422	12			15		100 µF 50 V	6 x 22 µF	8 X 100 µF 2 X 1 µF 1 X 0.1 µF	1.12	1.16	145	28	-/+46	60	7.5 (5 A/µs)	74	14	PI3423	12	15	100 µF 50 V	6 x 22 µF	8 X 100 µF 2 X 1 µF 1 X 0.1 µF	1.20	1.15	179	26	-/+73	70	7.5 (5 A/µs)	97	17	PI3424	12	15	100 µF 50 V	6 x 22 µF	8 X 47 µF 2 X 1 µF 1 X 0.1 µF	1.29	1.13	209	34	-/+98	60	7.5 (5 A/µs)	98	24.8					
PI3422	12	15	100 µF 50 V	6 x 22 µF	8 X 100 µF 2 X 1 µF 1 X 0.1 µF	1.12	1.16	145			28	-/+46	60	7.5 (5 A/µs)																																															
		74						14	PI3423	12	15				100 µF 50 V	6 x 22 µF	8 X 100 µF 2 X 1 µF 1 X 0.1 µF	1.20	1.15	179	26	-/+73	70	7.5 (5 A/µs)	97	17	PI3424	12	15	100 µF 50 V	6 x 22 µF	8 X 47 µF 2 X 1 µF 1 X 0.1 µF	1.29	1.13	209	34	-/+98	60	7.5 (5 A/µs)	98	24.8																				
PI3423	12	15	100 µF 50 V	6 x 22 µF	8 X 100 µF 2 X 1 µF 1 X 0.1 µF	1.20	1.15	179			26	-/+73	70	7.5 (5 A/µs)																																															
		97						17	PI3424	12	15				100 µF 50 V	6 x 22 µF	8 X 47 µF 2 X 1 µF 1 X 0.1 µF	1.29	1.13	209	34	-/+98	60	7.5 (5 A/µs)	98	24.8																																			
PI3424	12	15	100 µF 50 V	6 x 22 µF	8 X 47 µF 2 X 1 µF 1 X 0.1 µF	1.29	1.13	209			34	-/+98	60	7.5 (5 A/µs)																																															
		98						24.8																																																					

Table 5 — Recommended input and output capacitance

Murata Part Number	Description
GRM188R71C105KA12D	1 μ F 16 V 0603 X7R
GRM319R71H104KA01D	0.1 μ F 50 V 1206 X7R
GRM31CR60J107ME39L	100 μ F 6.3 V 1206 X5R
GRM31CR61A476ME15L	47 μ F 10 V 1206 X5R
GRM31CR61E226KE15L	22 μ F 25 V 1206 X5R

Table 6 — Capacitor manufacturer part numbers

Layout Guidelines

To achieve maximum efficiency and low noise performance from a PI34xx-00 design, layout considerations are necessary. Reducing trace resistance and minimizing high current loop returns along with proper component placement will contribute to optimal performance.

A typical buck regulator circuit is shown in Figure 41. The potential areas of high parasitic inductance and resistance are the circuit return paths, shown as LR below.

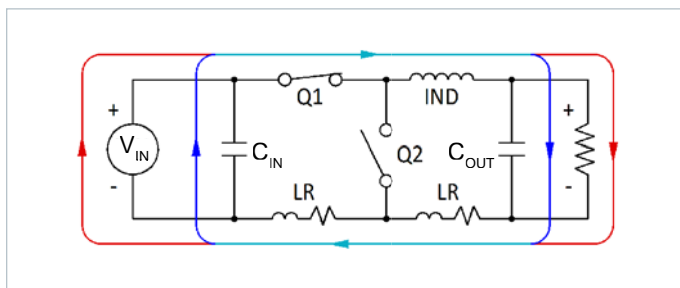

Figure 41 — Typical Buck Regulator

The path between the C_OUT and C_IN capacitors is of particular importance since the AC currents are flowing through both of them when Q1 is turned on.

Figure 42, schematically, shows the reduced trace length between input and output capacitors. The shorter path lessens the effects that copper trace parasitics can have on the PI34xx-00 performance.

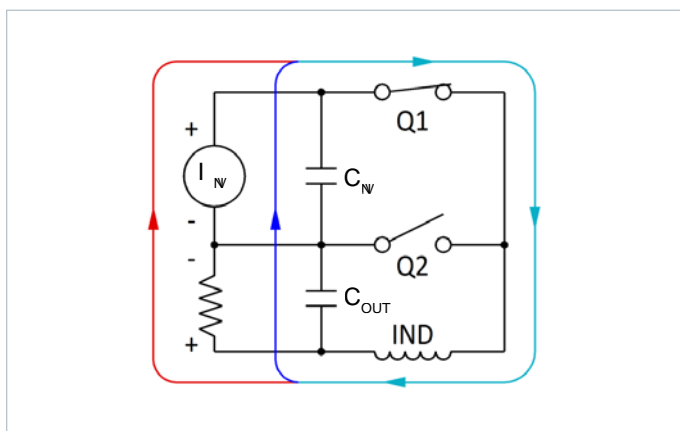

Figure 42 — Current flow: Q1 closed

When Q1 is on and Q2 is off, the majority of C_IN's current is used to satisfy the output load and to recharge the C_OUT capacitors. When Q1 is off and Q2 is on, the load current is supplied by the inductor and the C_OUT capacitor as shown in Figure 43. During this period C_IN is also being recharged by the V_IN. Minimizing C_IN loop inductance is important to reduce peak voltage excursions when Q1 turns off. Also, the difference in area between the C_IN loop and C_OUT loop is vital to minimize switching and GND noise.

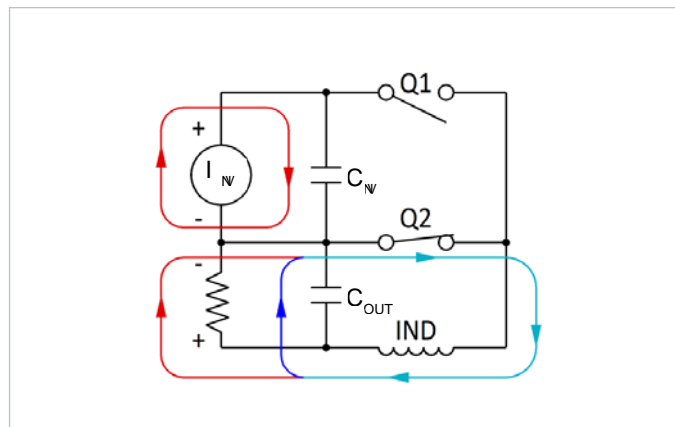

Figure 43 — Current flow: Q2 closed

The recommended component placement, shown in Figure 44, illustrates the tight path between C_IN and C_OUT (and V_IN and V_OUT) for the high AC return current. This optimized layout is used on the PI34xx-00 evaluation board.

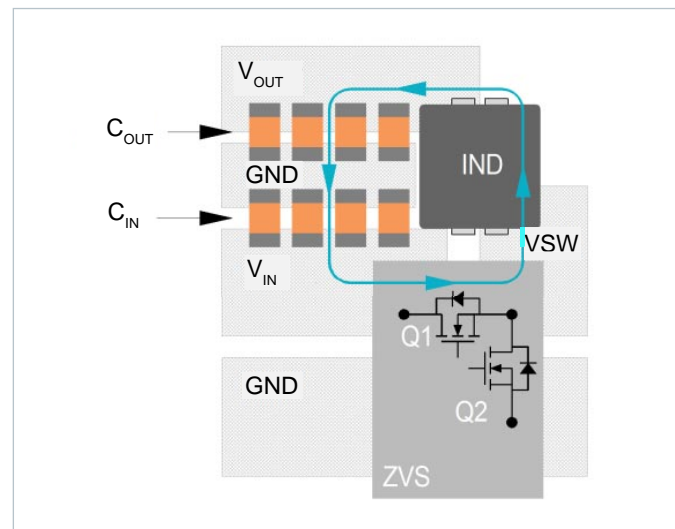

Figure 44 — Recommended component placement and metal routing

Figure 45 details the recommended receiving footprint for PI34xx-00 10 mm x 14 mm package. All pads should have a final copper size of 0.55 mm x 0.55 mm, whether they are solder-mask defined or copper defined, on a 1 mm x 1 mm grid. All stencil openings are 0.55 mm when using 6mil stencil.

Recommended PCB Footprint and Stencil

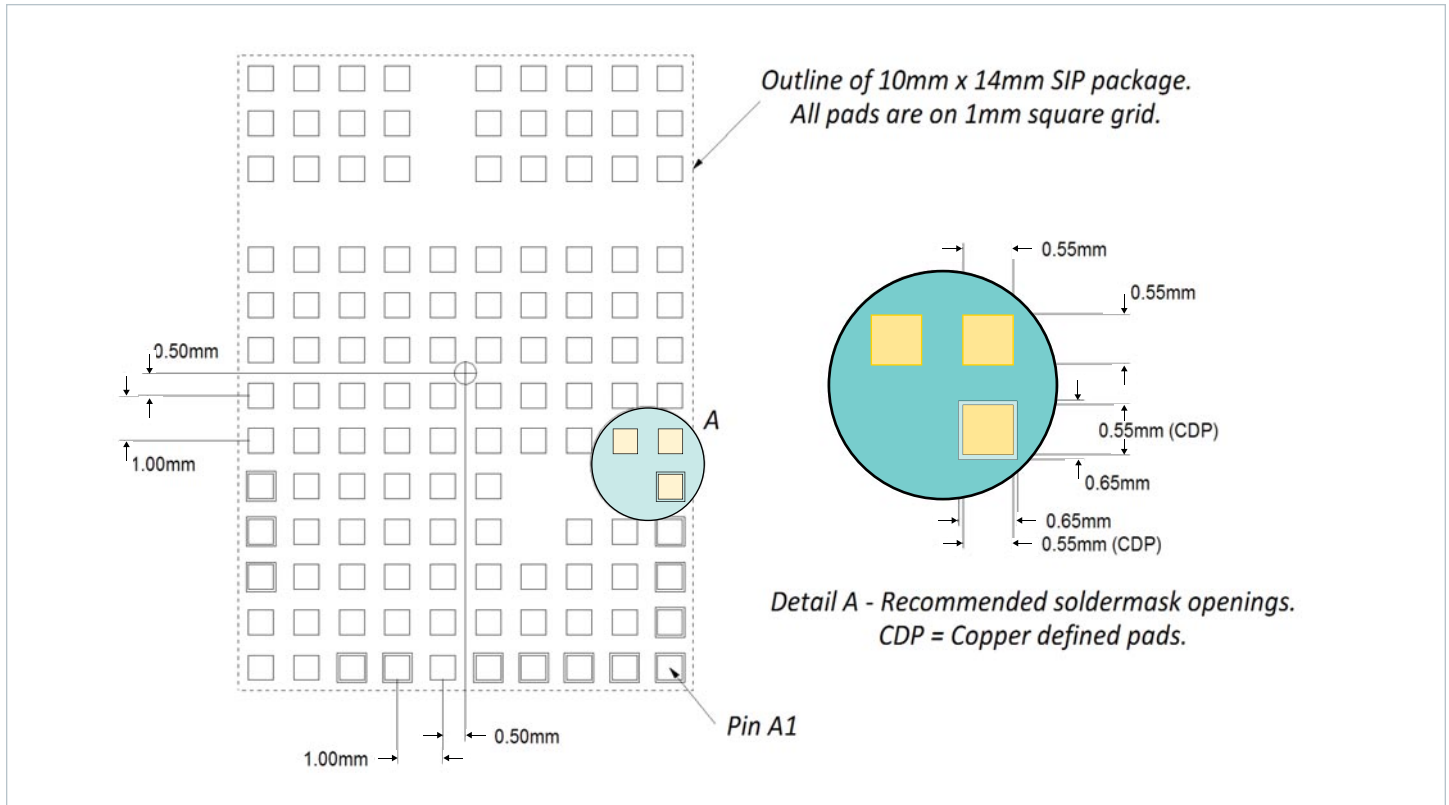
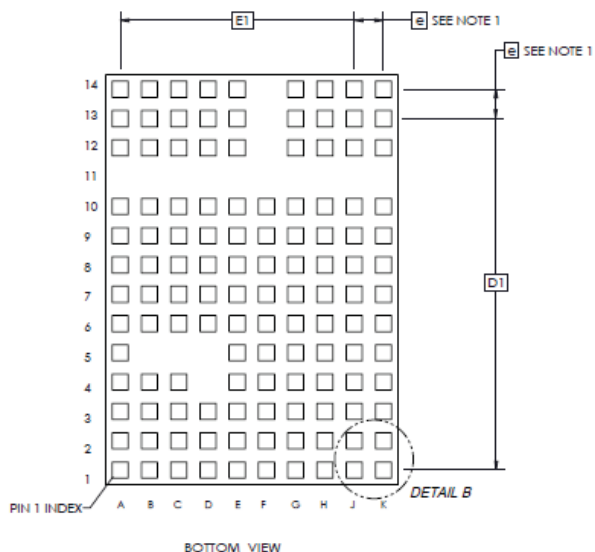
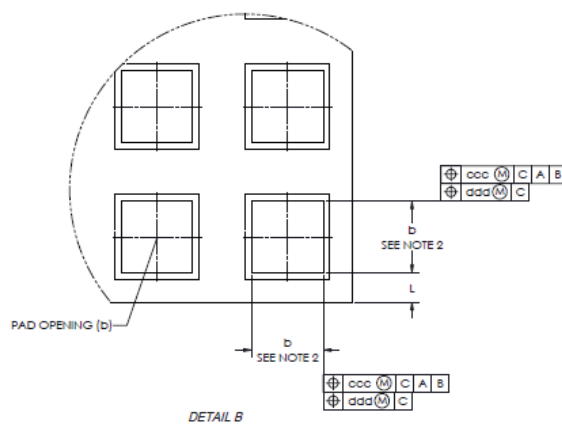
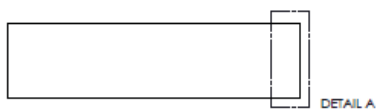
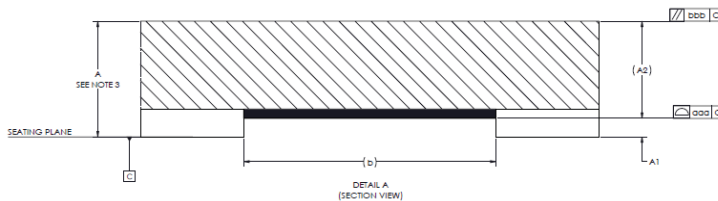
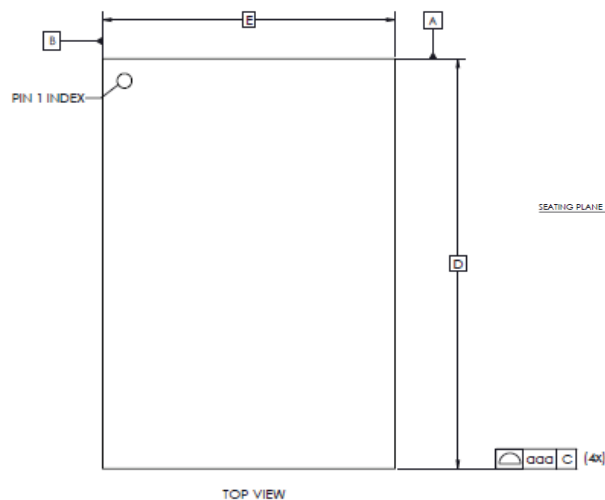

Figure 45 — Recommended Receiving PCB footprint

Package Drawings



DIMENSIONAL REFERENCES			
REF.	MIN.	NOM.	MAX.
A	2.49	2.56	2.63
A1	--	--	0.04
A2	--	--	2.59
b	0.50	0.55	0.60
D	14.00 BSC		
E	10.00 BSC		
D1	13.00 BSC		
E1	9.00 BSC		
e	1.00 BSC		
L	0.200	0.225	0.250

NOTES:

- 'e' REPRESENTS THE BASIC TERMINAL PITCH. SPECIFIES THE TRUE GEOMETRIC POSITION OF THE TERMINAL AXIS.
- DIMENSION 'b' APPLIES TO METALLIZED TERMINAL AND IS MEASURED BETWEEN 0.00mm AND 0.25mm FROM TERMINAL TIP.
- DIMENSION 'A' INCLUDES PACKAGE WARPAGE
- EXPOSED METALLIZED PADS ARE Cu PADS WITH SURFACE FINISH PROTECTION.
- RoHS COMPLIANT PER CST-0001 LATEST REVISION.

DIMENSIONAL REFERENCES	
REF.	TOLERANCE OF FORM AND POSITION
aaa	0.10
bbb	0.10
ccc	0.08
ddd	0.10

Revision History

Revision	Date	Description	Page Number(s)
1.0	02/13	Last release in old format	n/a
1.1	08/03/15	Reformatted in new template	n/a
1.2	09/03/15	Inductor pairing table updates	6, 7 & 25
1.3	12/21/15	Clarifications made in Enable Pin Conditions	7, 8, 11, 14, 17 & 28

Vicor's comprehensive line of power solutions includes high density AC-DC and DC-DC modules and accessory components, fully configurable AC-DC and DC-DC power supplies, and complete custom power systems.

Information furnished by Vicor is believed to be accurate and reliable. However, no responsibility is assumed by Vicor for its use. Vicor makes no representations or warranties with respect to the accuracy or completeness of the contents of this publication. Vicor reserves the right to make changes to any products, specifications, and product descriptions at any time without notice. Information published by Vicor has been checked and is believed to be accurate at the time it was printed; however, Vicor assumes no responsibility for inaccuracies. Testing and other quality controls are used to the extent Vicor deems necessary to support Vicor's product warranty. Except where mandated by government requirements, testing of all parameters of each product is not necessarily performed.

Specifications are subject to change without notice.

Vicor's Standard Terms and Conditions

All sales are subject to Vicor's Standard Terms and Conditions of Sale, which are available on Vicor's webpage or upon request.

Product Warranty

In Vicor's standard terms and conditions of sale, Vicor warrants that its products are free from non-conformity to its Standard Specifications (the "Express Limited Warranty"). This warranty is extended only to the original Buyer for the period expiring two (2) years after the date of shipment and is not transferable.

UNLESS OTHERWISE EXPRESSLY STATED IN A WRITTEN SALES AGREEMENT SIGNED BY A DULY AUTHORIZED VICOR SIGNATORY, VICOR DISCLAIMS ALL REPRESENTATIONS, LIABILITIES, AND WARRANTIES OF ANY KIND (WHETHER ARISING BY IMPLICATION OR BY OPERATION OF LAW) WITH RESPECT TO THE PRODUCTS, INCLUDING, WITHOUT LIMITATION, ANY WARRANTIES OR REPRESENTATIONS AS TO MERCHANTABILITY, FITNESS FOR PARTICULAR PURPOSE, INFRINGEMENT OF ANY PATENT, COPYRIGHT, OR OTHER INTELLECTUAL PROPERTY RIGHT, OR ANY OTHER MATTER.

This warranty does not extend to products subjected to misuse, accident, or improper application, maintenance, or storage. Vicor shall not be liable for collateral or consequential damage. Vicor disclaims any and all liability arising out of the application or use of any product or circuit and assumes no liability for applications assistance or buyer product design. Buyers are responsible for their products and applications using Vicor products and components. Prior to using or distributing any products that include Vicor components, buyers should provide adequate design, testing and operating safeguards.

Vicor will repair or replace defective products in accordance with its own best judgment. For service under this warranty, the buyer must contact Vicor to obtain a Return Material Authorization (RMA) number and shipping instructions. Products returned without prior authorization will be returned to the buyer. The buyer will pay all charges incurred in returning the product to the factory. Vicor will pay all reshipment charges if the product was defective within the terms of this warranty.

Life Support Policy

VICOR'S PRODUCTS ARE NOT AUTHORIZED FOR USE AS CRITICAL COMPONENTS IN LIFE SUPPORT DEVICES OR SYSTEMS WITHOUT THE EXPRESS PRIOR WRITTEN APPROVAL OF THE CHIEF EXECUTIVE OFFICER AND GENERAL COUNSEL OF VICOR CORPORATION. As used herein, life support devices or systems are devices which (a) are intended for surgical implant into the body, or (b) support or sustain life and whose failure to perform when properly used in accordance with instructions for use provided in the labeling can be reasonably expected to result in a significant injury to the user. A critical component is any component in a life support device or system whose failure to perform can be reasonably expected to cause the failure of the life support device or system or to affect its safety or effectiveness. Per Vicor Terms and Conditions of Sale, the user of Vicor products and components in life support applications assumes all risks of such use and indemnifies Vicor against all liability and damages.

Intellectual Property Notice

Vicor and its subsidiaries own Intellectual Property (including issued U.S. and Foreign Patents and pending patent applications) relating to the products described in this data sheet. No license, whether express, implied, or arising by estoppel or otherwise, to any intellectual property rights is granted by this document. Interested parties should contact Vicor's Intellectual Property Department.

The products described on this data sheet are protected by the following U.S. Patents Numbers:

6,788,033; 7,154,250; 7,561,446; 7,361,844; D496,906; D506,438; 6,940,013; 7,038,917; 6,969,909; 7,166,898; 6,421,262; 7,368,957; RE 40,072

Vicor Corporation
25 Frontage Road
Andover, MA 01810 USA

Picor Corporation
51 Industrial Drive
North Smithfield, RI 02896 USA

email

Customer Service: custserv@vicorpower.com

Technical Support: apps@vicorpower.com