

Remote 16-bit I/O Expander for Fm+ I²C-bus with Interrupt and Reset

Description

The PI4IOE5V9673 provides general purpose remote I/O expansion for most microcontroller families via the two-line bidirectional bus (I²C-bus) and is a part of the Fast-mode Plus family.

The PI4IOE5V9673 provides higher Fast-mode Plus (Fm+) I²C-bus speeds (1 MHz versus 400 kHz) so that the output can support PWM dimming of LEDs, high I²C-bus drive (30 mA) so that many more devices can be on the bus without the need for bus buffers, high total package sink capacity (400 mA) that supports having all 25 mA LEDs on at the same time and more device addresses (16) are available to allow many more devices on the bus without address conflicts.

The device consists of a 16-bit quasi-bidirectional port and an I²C-bus interface. The PI4IOE5V9673 has a low current consumption and includes latched outputs with high current drive capability for directly driving LEDs. It also possesses an interrupt line ($\overline{\text{INT}}$) which can be connected to the interrupt logic of the microcontroller. By sending an interrupt signal on this line, the remote I/O can inform the microcontroller if there is incoming data on its ports without having to communicate via the I²C-bus. The internal Power-On Reset (POR) or software reset sequence initializes the I/Os as inputs.

Features

- Operation Power Supply Voltage from 2.3V to 5.5V
- 16-bit Remote I/O Pins that Default to Inputs at Power-up
- 1 MHz I²C-bus Interface
- Compliant with the I²C-bus Fast and Standard Modes
- 5.5V Tolerant I/Os
- SDA with 30 mA Sink Capability for 4000 pF Buses
- Latched Outputs with 25 mA Sink Capability for Directly Driving LEDs
- Total Package Sink Capability of 400 mA
- Active LOW Open-drain Interrupt Output
- Low Standby Current
- 16 Programmable Slave Addresses using 2 Address Pins
- ESD Protection (4KV HBM and 1KV CDM)
- Latch-up Tested (exceeds 100mA)
- Totally Lead-Free & Fully RoHS Compliant (Notes 1 & 2)
- Halogen and Antimony Free. "Green" Device (Note 3)
- For automotive applications requiring specific change control (i.e. parts qualified to AEC-Q100/101/104/200, PPAP capable, and manufactured in IATF 16949 certified facilities), please [contact us](mailto:contact_us) or your local Diodes representative.
<https://www.diodes.com/quality/product-definitions/>
- Packaging (Pb-free & Green):
 - 24-Pin, TQFN 4x4 (ZD)

Notes:

1. No purposely added lead. Fully EU Directive 2002/95/EC (RoHS), 2011/65/EU (RoHS 2) & 2015/863/EU (RoHS 3) compliant.
2. See <https://www.diodes.com/quality/lead-free/> for more information about Diodes Incorporated's definitions of Halogen- and Antimony-free, "Green" and Lead-free.
3. Halogen- and Antimony-free "Green" products are defined as those which contain <900ppm bromine, <900ppm chlorine (<1500ppm total Br + Cl) and <1000ppm antimony compounds.

PI4IOE5V9673 Block Diagram

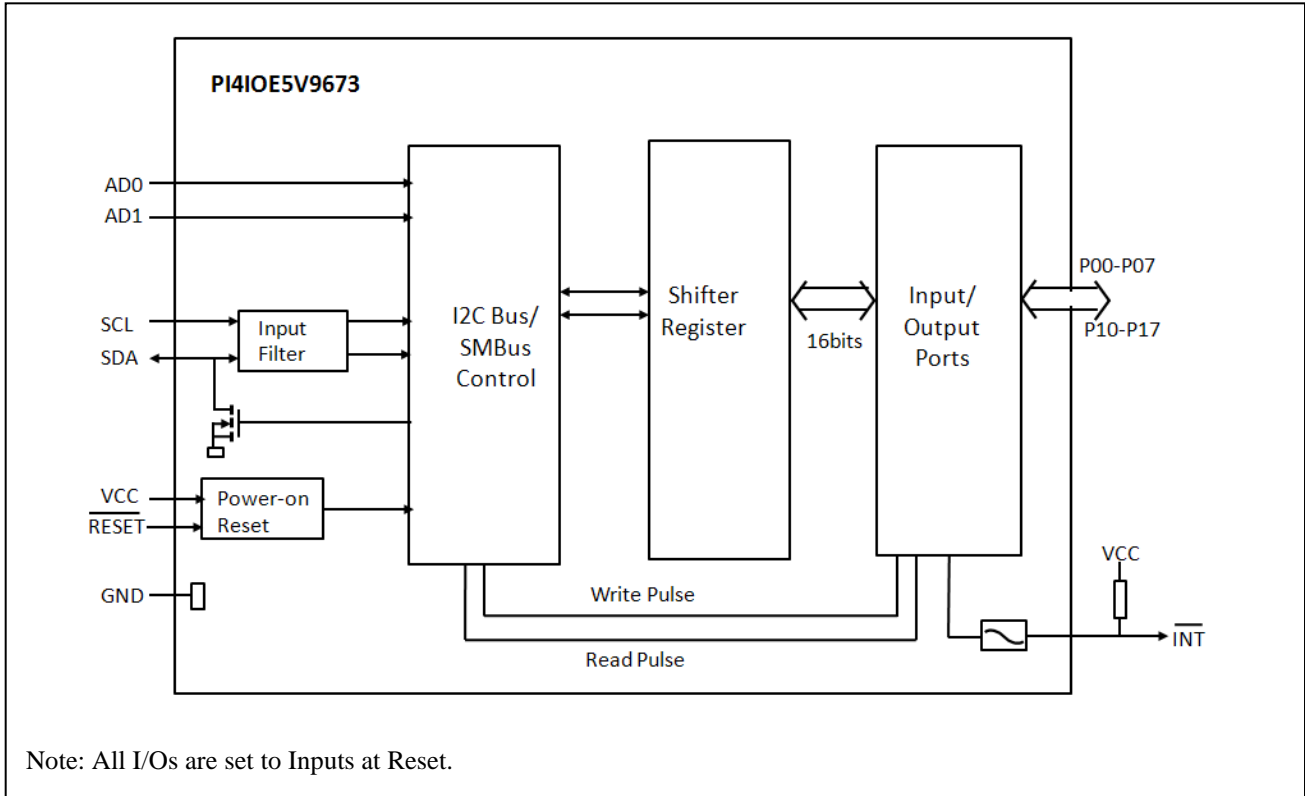

Pin Configuration

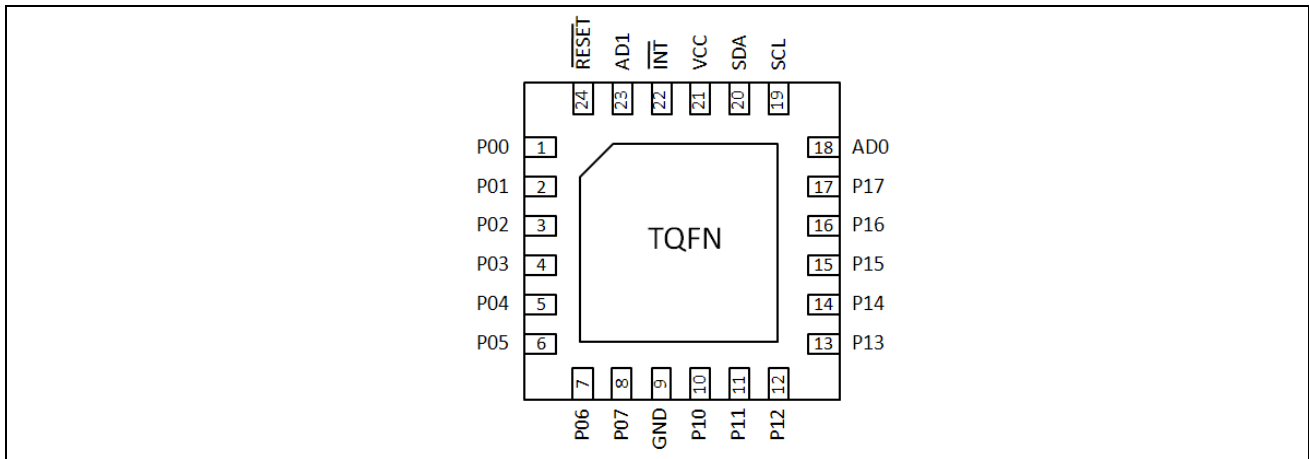

Pin Description

Pin#	Name	Type	Description
22	$\overline{\text{INT}}$	O	Interrupt input (open-drain)
23	AD1	I	Address input 1
24	$\overline{\text{RESET}}$	I	Reset input
1	P00	I/O	Port 0 input/output 0
2	P01	I/O	Port 0 input/output 1
3	P02	I/O	Port 0 input/output 2
4	P03	I/O	Port 0 input/output 3
5	P04	I/O	Port 0 input/output 4
6	P05	I/O	Port 0 input/output 5
7	P06	I/O	Port 0 input/output 6
8	P07	I/O	Port 0 input/output 7
9	GND	G	Ground
10	P10	I/O	Port 1 input/output 0
11	P11	I/O	Port 1 input/output 1
12	P12	I/O	Port 1 input/output 2
13	P13	I/O	Port 1 input/output 3
14	P14	I/O	Port 1 input/output 4
15	P15	I/O	Port 1 input/output 5
16	P16	I/O	Port 1 input/output 6
17	P17	I/O	Port 1 input/output 7
18	AD0	I	Address input 0
19	SCL	I	Serial clock line input
20	SDA	I	Serial data line open-drain
21	VCC	P	Supply voltage

* I = Input; O = Output; P = Power; G = Ground

Maximum Ratings

Power Supply.....	-0.5V to +6.0V
Voltage on an I/O Pin.....	GND-0.5V to +6.0V
Input Current	±20mA
Output Current on an I/O Pin	±50mA
Supply Current.....	±160mA
Ground Supply Current.....	600mA
Total Power Dissipation.....	600mW
Operation Temperature.....	-40 to 85°C
Storage Temperature	-65 to 150°C
Maximum Junction Temperature, T _{j(max)}	125°C

Note:

Stresses greater than those listed under **MAXIMUM RATINGS** may cause permanent damage to the device. This is a stress rating only and functional operation of the device at these or any other conditions above those indicated in the operational sections of this specification is not implied. Exposure to absolute maximum rating conditions for extended periods may affect reliability.

Static Characteristics

VCC = 2.3V to 5.5V; GND = 0V; Tamb = -40°C to +85°C; unless otherwise specified.

Symbol	Parameter	Conditions	Min.	Typ.	Max.	Unit
Power Supply						
VCC	Supply voltage		2.3	-	5.5	V
I _{CC}	Supply current	Operating mode; VCC = 5.5V; no load; f _{SCL} = 1MHz		200	500	µA
I _{sb}	Standby current	Standby mode; VCC = 5.5V; no load; VI = VCC; f _{SCL} = 0kHz; I/O = inputs		2.5	10	uA
V _{POR}	Power-on reset voltage ^[1]			1.16	1.41	V
Input SCL, Input/Output SDA						
V _{IL}	Low level input voltage		-0.5		+0.3 VCC	V
V _{IH}	High level input voltage		0.7 VCC		5.5	V
I _{OL}	Low level output current	V _{OL} = 0.4V; VCC = 2.3V	16			mA
		V _{OL} = 0.4V; VCC = 3V	18			mA
		V _{OL} = 0.4V; VCC = 4.5V	20			mA
I _L	Leakage current	V _I = VCC = GND	-1		1	µA
C _i	Input capacitance	V _I = GND		4	10	pF
I/Os						
I _{OL}	Low level output current	VCC = 2.3 V; V _{OL} = 0.5 V ^[2]	12	27		mA
		VCC = 3.0V; V _{OL} = 0.5V ^[2]	17	35		mA
		VCC = 4.5V; V _{OL} = 0.5 V ^[2]	25	42		mA
I _{OL(tot)}	total LOW-level output current	V _{OL} = 0.5V; VCC = 4.5V			400	mA
I _{OH}	HIGH-level output current	V _{OH} = GND	-30	-359	-480	uA
I _{trt(pu)}	transient boosted pull-up current	V _{OH} = GND	-0.5	-1.0		mA
C _i	Off-state Input capacitance	^[3]		4	10	pF
C _o	Off-state Output capacitance	^[3]		4	10	pF
Interrupt INT						
I _{OL}	Low level output current	V _{OL} = 0.4V	6			mA

Symbol	Parameter	Conditions	Min.	Typ.	Max.	Unit
C _o	Output capacitance			3	10	pF
Interrupt RESET						
V _{IL}	Low level input voltage		-0.5		0.8	V
V _{IH}	High level input voltage		2		5.5	V
I _L	Input leakage current		-1		1	μA
C _i	Input capacitance			3	10	pF
Select Inputs AD0, AD1						
V _{IL}	Low level input voltage		-0.5		0.8	V
V _{IH}	High level input voltage		2		5.5	V
I _L	Input leakage current		-1		1	μA
C _i	Input capacitance			3	5	pF

Note:

- VCC must be lowered to 0.2 V for at least 20 us in order to reset part.
- Each I/O must be externally limited to a maximum of 25 mA and the total package limited to 400 mA due to internal busing limits.
- The value is not tested, but verified on sampling basis.

Dynamic Characteristics

Symbol	Parameter	Standard Mode I ² C		Fast Mode I ² C		Fast Mode Plus I ² C		Unit
		Min	Max	Min	Max	Min	Max	
f _{SCL}	SCL clock frequency	0	100	0	400	0	1000	kHz
t _{BUF}	bus free time between a STOP and START condition	4.7		1.3		0.5		μs
t _{HD:STA}	hold time (repeated) START condition	4.0		0.6		0.26		μs
t _{SU:STA}	set-up time for a repeated START condition	4.7		0.6		0.26		μs
t _{SU:STO}	set-up time for STOP condition	4.0		0.6		0.26		μs
t _{VD:ACK} ^[1]	data valid acknowledge time		3.45		0.9		0.45	μs
t _{HD:DAT} ^[2]	data hold time	0		0		0		ns
t _{VD:DAT}	data valid time		3.45		0.9		0.45	ns
t _{SU:DAT}	data set-up time	250		100		50		ns
t _{LOW}	LOW period of the SCL clock	4.7		1.3		0.5		μs
t _{HIGH}	HIGH period of the SCL clock	4.0		0.6		0.26		μs
t _f	fall time of both SDA and SCL signals		300		300		120	ns
t _r	rise time of both SDA and SCL signals		1000		300		120	ns
t _{SP}	pulse width of spikes that must be suppressed by the input filter		50		50		50	ns
Port Timing C_L ≤ 100pF								
t _{v(Q)}	Data output valid time ^[3]		4		4		4	ns
t _{su(D)}	Data input set-up time	0		0		0		ns
T _{h(D)}	Data input hold time	4		4		4		μs
Interrupt Timing C_L ≤ 100pF								
t _{v(INT)}	Valid time on pin $\overline{\text{INT}}$		4		4		4	μs
t _{rst(INT)}	Reset time on pin $\overline{\text{INT}}$		4		4		4	μs
Reset Timing								
t _{w(rst)}	Reset pulse width		25		25		25	ns
t _{rec(rst)}	Reset recovery time		0		0		0	ns

Symbol	Parameter	Standard Mode I ² C		Fast Mode I ² C		Fast Mode Plus I ² C		Unit
		Min	Max	Min	Max	Min	Max	
t _{rst}	Reset time		1		1		1	us
td(rst)	Reset time on pin $\overline{\text{INT}}$		4		4		4	μs

Note:

1. t_{VD,ACK} = time for acknowledgement signal from SCL LOW to SDA (out) LOW.
2. t_{VD,DAT} = minimum time for SDA data out to be valid following SCL LOW.
3. t_{v(Q)} measured from 0.7VCC on SCL to 50% I/O output.

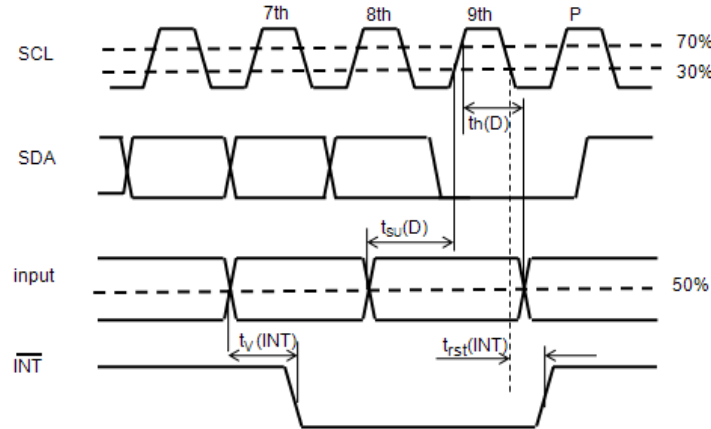

Figure 1. Timing Parameters for INT Signal

Details Description

Device Address

Following a START condition, the bus master must send the address of the slave it is accessing and the operation it wants to perform (read or write). The address of the PI4IOE5V9673 is shown in bellow. Slave address pins AD1, and AD0 choose 1 of 16 slave addresses. To conserve power, no internal pull-up resistors are incorporated on AD2, AD1, and AD0. Address values depending on AD1, and AD0 can be found in Table “PI4IOE5V9673 address map”.

Remark: The General Call address (0000 0000b) and the Device ID address (1111 100Xb) are reserved and cannot be used as device address. Failure to follow this requirement will cause the PI4IOE5V9673 not to acknowledge.

Remark: Reserved I2C-bus addresses must be used with caution since they can interfere with:

- “reserved for future use” I2C-bus addresses (0000 011, 1111 101, 1111 110, 1111 111)
- slave devices that use the 10-bit addressing scheme (1111 0xx)
- High speed mode (Hs-mode) master code (0000 1xx)

PI4IOE5V9673 Address

	b7(MSB)	b6	b5	b4	b3	b2	b1	b0
Address Byte	A6	A5	A4	A3	A2	A1	A0	R/W

The last bit of the first byte defines the operation to be performed. When set to logic 1 a read is selected, while a logic 0 selects a write operation.

PI4IOE5V9673 Address Maps

AD1	AD0	A6	A5	A4	A3	A2	A1	A0	Address (Write)	Address (Read)
SCL	GND	0	0	1	0	1	0	0	28h	29h
SCL	VCC	0	0	1	0	1	0	1	2Ah	2Bh
SDA	GND	0	0	1	0	1	1	0	2Ch	2Dh
SDA	VCC	0	0	1	0	1	1	1	2Eh	2Fh
SCL	SCL	0	0	1	1	0	0	0	38h	39h
SCL	SDA	0	0	1	1	0	0	1	3Ah	3Bh
SDA	SCL	0	0	1	1	0	1	0	3Ch	3Dh
SDA	SDA	0	0	1	1	0	1	1	3Eh	3Fh
GND	GND	0	1	0	0	1	0	0	48h	49h
GND	VCC	0	1	0	0	1	0	1	4Ah	4Bh
VCC	GND	0	1	0	0	1	1	0	4Ch	4Dh
VCC	VCC	0	1	0	0	1	1	1	4Eh	4Fh
GND	SCL	0	1	0	1	1	0	0	58h	59h
GND	SDA	0	1	0	1	1	0	1	5Ah	5Bh
VCC	SCL	0	1	0	1	1	1	0	5Ch	5Dh
VCC	SDA	0	1	0	1	1	1	1	5Eh	5Fh

Software Reset Call

• General Call address: allows to reset the PI4IOE5V9673 through the I²C-bus upon reception of the right C-bus sequence.

	b7(MSB)	b6	b5	b4	b3	b2	b1	b0
General Call Address	0	1	0	0	1	0	0	R/W

Software Reset

The Software Reset Call allows all the devices in the I²C-bus to be reset to the power-up state value through a specific formatted I²C-bus command. To be performed correctly, it implies that the I²C-bus is functional and that there is no device hanging the bus.

The Software Reset sequence is defined as following:

1. A START command is sent by the I²C-bus master.
2. The reserved General Call I²C-bus address '0000 000' with the R/W bit set to 0 (write) is sent by the I²C-bus master.
3. The device acknowledges after seeing the General Call address '0000 0000' (00h) only. If the R/W bit is set to 1 (read), no acknowledge is returned to the I²C-bus master.
4. Once the General Call address has been sent and acknowledged, the master sends 1 byte. The value of the byte must be equal to 06h.
 - a. The device acknowledges this value only. If the byte is not equal to 06h, the device does not acknowledge it.
 - b. If more than 1 byte of data is sent, the device does not acknowledge any more.
5. Once the right byte has been sent and correctly acknowledged, the master sends a STOP command to end the Software Reset sequence: the device then resets to the default value (power-up value) and is ready to be addressed again within the specified bus free time. If the master sends a Repeated START instead, no reset is performed.

The I²C-bus master must interpret a non-acknowledge from the device (at any time) as a 'Software Reset Abort'. The device does not initiate a reset of its registers.

The unique sequence that initiates a Software Reset is described in Figure 5.

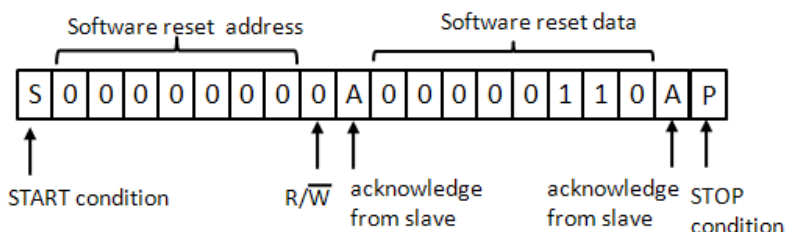

Figure 2. Software Reset Sequence

Quasi-bidirectional I/O Architecture

The PI4IOE5V9673's 16 ports (see Figure 6) are entirely independent and can be used either as input or output ports. Input data is transferred from the ports to the microcontroller in the Read mode. Output data is transmitted to the ports in the Write mode.

Every data transmission from the PI4IOE5V9673 must consist of an even number of bytes, the first byte will be referred to as P07 to P00, and the second byte as P17 to P10. The third will be referred to as P07 to P00, and so on.

This quasi-bidirectional I/O can be used as an input or output without the use of a control signal for data directions. At power-on the I/Os are HIGH. In this mode only a current source (I_{OH}) to VCC is active. An additional strong pull-up to VCC ($I_{trt}(pu)$) allows fast rising edges into heavily loaded outputs. These devices turn on when an output is written HIGH, and are switched off by the negative edge of SCL. The I/Os should be HIGH before being used as inputs. After power-on, as all the I/Os are set HIGH, all of them can be used as inputs. Any change in setting of the I/Os as either inputs or outputs can be done with the write mode.

Remark: If a HIGH is applied to an I/O which has been written earlier to LOW, a large current (I_{OL}) will flow to GND.

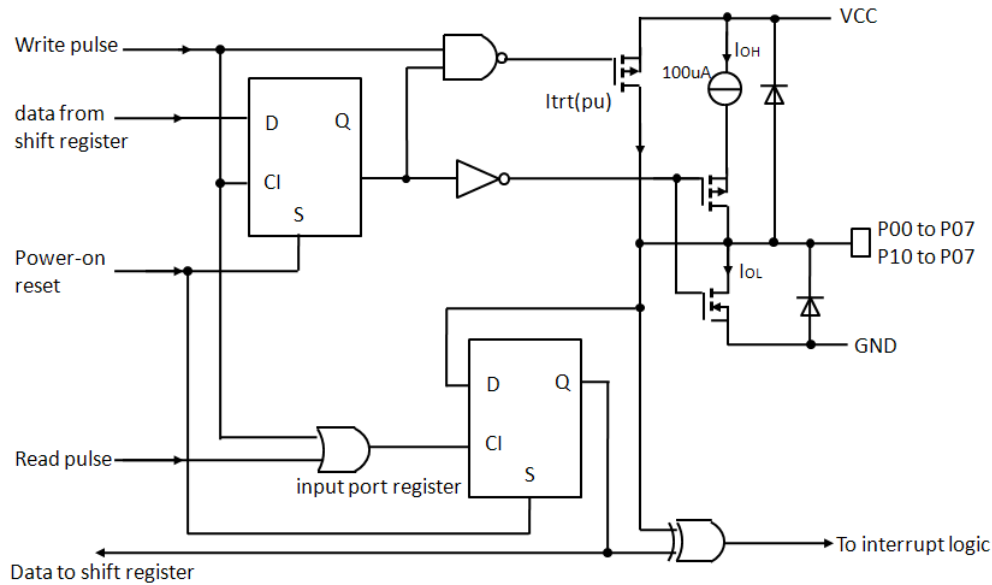

Figure 3. Simplified schematic diagram of P00 to P17

Writing to the Port (Output Mode)

To write, the master (microcontroller) first addresses the slave device. By setting the last bit of the byte containing the slave address to logic 0 the Write mode is entered. The PI4IOE5V9673 acknowledges and the master sends the first data byte for P07 to P00. After the first data byte is acknowledged by the PI4IOE5V9673, the second data byte P17 to P10 is sent by the master. Once again, the PI4IOE5V9673 acknowledges the receipt of the data. Each 8-bit data is presented on the port lines after it has been acknowledged by the PI4IOE5V9673.

The number of data bytes that can be sent successively is not limited. After every two bytes, the previous data is overwritten.

The first data byte in every pair refers to Port 0 (P07 to P00), whereas the second data byte in every pair refers to Port 1 (P17 to P10).

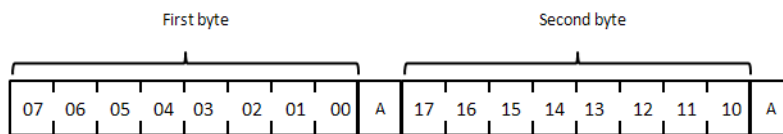

Figure 4. Correlation between Bits and Ports

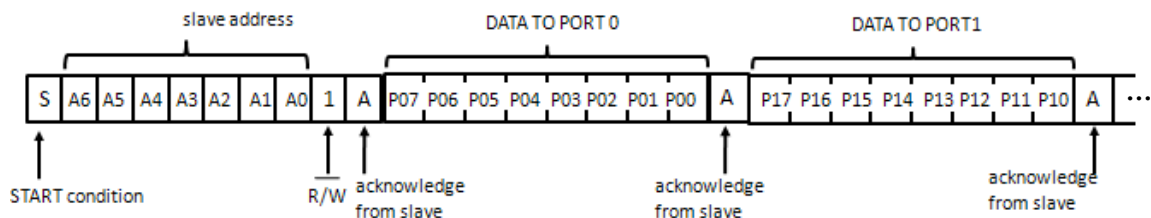

Figure 5. Write Mode

Reading from a Port (Input Mode)

All ports programmed as input should be set to logic 1. To read, the master (microcontroller) first addresses the slave device after it receives the interrupt. By setting the last bit of the byte containing the slave address to logic 1 the Read mode is entered.

The data bytes that follow on the SDA are the values on the ports.

If the data on the input port changes faster than the master can read, this data may be lost. Transfer of data can be

stopped at any moment by a STOP condition. When this occurs, data present at the latest acknowledge phase is valid.

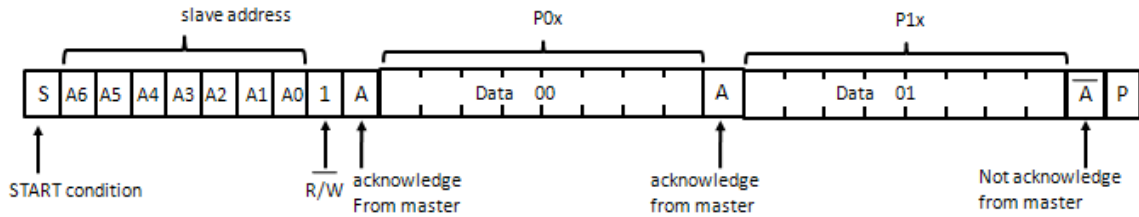

Figure 6. Read Input Port Register

Power-on Reset

When power is applied to VCC, an internal Power-On Reset (POR) holds the PI4IOE5V9673 in a reset condition until VCC has reached VPOR. At that point, the reset condition is released and the PI4IOE5V9673 registers and I2C-bus/SMBus state machine will initialize to their default states. Thereafter VCC must be lowered below 0.2 V to reset the device.

Interrupt Output (INT)

The PI4IOE5V9673 provides an open-drain interrupt (INT) which can be fed to a corresponding input of the microcontroller. This gives these chips a kind of master function which can initiate an action elsewhere in the system. An interrupt is generated by any rising or falling edge of the port inputs. After time $t_{(V)D}$ the signal INT is valid. The interrupt disappears when data on the port is changed to the original setting or data is read from or written to the device which has generated the interrupt. In the write mode, the interrupt may become deactivated (HIGH) on the rising edge of the write to port pulse. On the falling edge of the write to port pulse the interrupt is definitely deactivated (HIGH). The interrupt is reset in the read mode on the rising edge of the read from port pulse. During the resetting of the interrupt itself, any changes on the I/Os may not generate an interrupt. After the interrupt is reset any change in I/Os will be detected and transmitted as an INT.

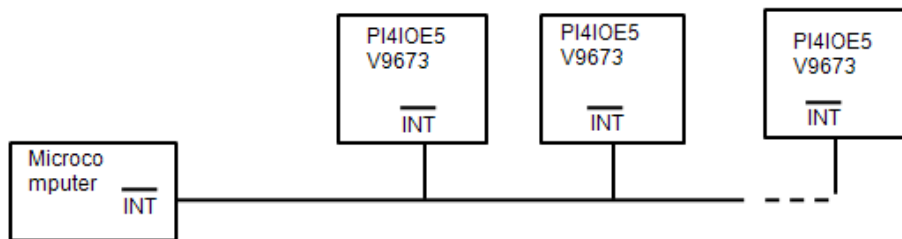

Figure 7. Application of Multiple P4IOE5V9673s with Interrupt

RESET Input

A reset can be accomplished by holding the RESET pin LOW for a minimum of $t_{w(rst)}$. The PI4IOE5V9673 registers and I2C-bus state machine will be held in their default state until the RESET input is once again HIGH. The I2C-bus is for 2-way, 2-line communication between different ICs or modules. The two lines are a serial data line (SDA) and a serial clock line (SCL). Both lines must be connected to a positive supply via a pull-up resistor when connected to the output stages of a device. Data transfer may be initiated only when the bus is not busy.

Bidirectional I/O Expander Applications

In the 8-bit I/O expander application shown in Figure 11, P00 and P01 are inputs, and P02 to P07 are outputs. When used in this configuration, during a write, the input (P00 and P01) must be written as HIGH so the external devices fully

control the input ports. The desired HIGH or LOW logic levels may be written to the I/Os used as outputs (P02 to P07). During a read, the logic levels of the external devices driving the input ports (P00 and P01) and the previous written logic level to the output ports (P02 to P07) will be read. The GPIO also has an interrupt line (INT) that can be connected to the interrupt logic of the microprocessor. By sending an interrupt signal on this line, the remote I/O informs the microprocessor that there is incoming data or a change of data on its ports without having to communicate via the I2C-bus.

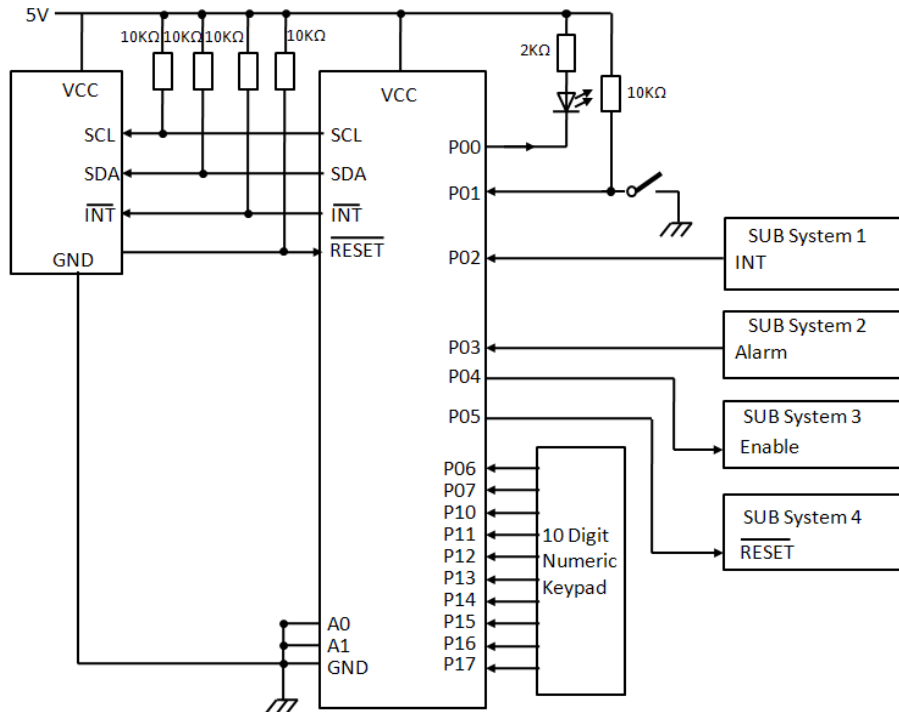

Figure 8. Bidirectional I/O Expander Application

High Current-drive Load Applications

The GPIO has a maximum sinking current of 25 mA per bit. In applications requiring additional drive, two port pins in the same octal may be connected together to sink up to 50 mA current. Both bits must then always be turned on or off together. Up to 8 pins (one octal) can be connected together to drive 200 mA.

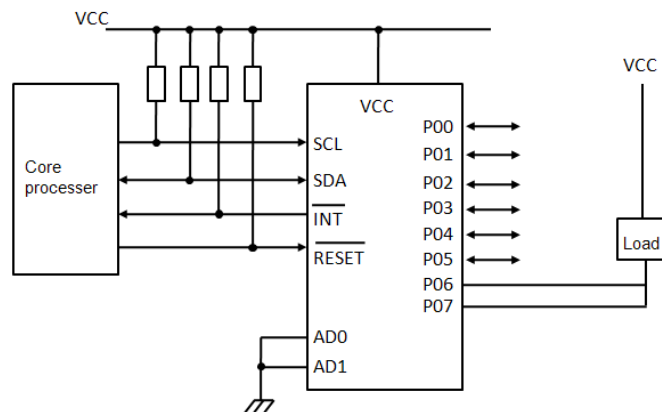

Figure 9. High Current-drive Load Application

Part Marking

Top mark not available at this time. To obtain advance information regarding the top mark, please contact your local sales representative.

Packaging Mechanical

24-TQFN (ZD)

SYMBOLS	MIN.	NOM.	MAX.
A	0.80	0.85	0.90
A1	0.00	0.02	0.05
A3	0.20 REF.		
b	0.18	0.25	0.30
D	3.90	4.00	4.10
E	3.90	4.00	4.10
e	0.50 BSC		
D2	2.15	—	2.75
E2	2.15	—	2.75
L	0.35	0.40	0.45

NOTE :
 1. ALL DIMENSIONS ARE IN mm. ANGLES IN DEGREES.
 2. COPLANARITY APPLIES TO THE EXPOSED THERMAL PAD AS WELL AS THE TERMINALS.
 3. REFER JEDEC MO-220
 4. RECOMMENDED LAND PATTERN IS FOR REFERENCE ONLY.
 5. THERMAL PAD SOLDERING AREA
 6. MAJOR EDAP D2XE2=2.25X2.25

DATE: 07/07/17
DESCRIPTION: 24-Contact, Very Thin Quad Flat No-Lead (TQFN)
PACKAGE CODE: ZD (ZD24)
DOCUMENT CONTROL #: PD-2100
REVISION: C

17-0533

For latest package info.

please check: <http://www.diodes.com/design/support/packaging/pericom-packaging/packaging-mechanicals-and-thermal-characteristics/>

Ordering Information

Orderable Part Number	Package	Package Description
PI4IOE5V9673ZDEX	ZD	24-Contact, Very Thin Quad Flat No-Lead (TQFN)

Notes:

- No purposely added lead. Fully EU Directive 2002/95/EC (RoHS), 2011/65/EU (RoHS 2) & 2015/863/EU (RoHS 3) compliant.
- See <https://www.diodes.com/quality/lead-free/> for more information about Diodes Incorporated's definitions of Halogen- and Antimony-free, "Green" and Lead-free.
- Halogen- and Antimony-free "Green" products are defined as those which contain <900ppm bromine, <900ppm chlorine (<1500ppm total Br + Cl) and <1000ppm antimony compounds.
- E = Pb-free and Green
- X suffix = Tape/Reel

IMPORTANT NOTICE

1. DIODES INCORPORATED (Diodes) AND ITS SUBSIDIARIES MAKE NO WARRANTY OF ANY KIND, EXPRESS OR IMPLIED, WITH REGARDS TO ANY INFORMATION CONTAINED IN THIS DOCUMENT, INCLUDING, BUT NOT LIMITED TO, THE IMPLIED WARRANTIES OF MERCHANTABILITY, FITNESS FOR A PARTICULAR PURPOSE OR NON-INFRINGEMENT OF THIRD PARTY INTELLECTUAL PROPERTY RIGHTS (AND THEIR EQUIVALENTS UNDER THE LAWS OF ANY JURISDICTION).

2. The Information contained herein is for informational purpose only and is provided only to illustrate the operation of Diodes' products described herein and application examples. Diodes does not assume any liability arising out of the application or use of this document or any product described herein. This document is intended for skilled and technically trained engineering customers and users who design with Diodes' products. Diodes' products may be used to facilitate safety-related applications; however, in all instances customers and users are responsible for (a) selecting the appropriate Diodes products for their applications, (b) evaluating the suitability of Diodes' products for their intended applications, (c) ensuring their applications, which incorporate Diodes' products, comply the applicable legal and regulatory requirements as well as safety and functional-safety related standards, and (d) ensuring they design with appropriate safeguards (including testing, validation, quality control techniques, redundancy, malfunction prevention, and appropriate treatment for aging degradation) to minimize the risks associated with their applications.

3. Diodes assumes no liability for any application-related information, support, assistance or feedback that may be provided by Diodes from time to time. Any customer or user of this document or products described herein will assume all risks and liabilities associated with such use, and will hold Diodes and all companies whose products are represented herein or on Diodes' websites, harmless against all damages and liabilities.

4. Products described herein may be covered by one or more United States, international or foreign patents and pending patent applications. Product names and markings noted herein may also be covered by one or more United States, international or foreign trademarks and trademark applications. Diodes does not convey any license under any of its intellectual property rights or the rights of any third parties (including third parties whose products and services may be described in this document or on Diodes' website) under this document.

5. Diodes' products are provided subject to Diodes' Standard Terms and Conditions of Sale (<https://www.diodes.com/about/company/terms-and-conditions/terms-and-conditions-of-sales/>) or other applicable terms. This document does not alter or expand the applicable warranties provided by Diodes. Diodes does not warrant or accept any liability whatsoever in respect of any products purchased through unauthorized sales channel.

6. Diodes' products and technology may not be used for or incorporated into any products or systems whose manufacture, use or sale is prohibited under any applicable laws and regulations. Should customers or users use Diodes' products in contravention of any applicable laws or regulations, or for any unintended or unauthorized application, customers and users will (a) be solely responsible for any damages, losses or penalties arising in connection therewith or as a result thereof, and (b) indemnify and hold Diodes and its representatives and agents harmless against any and all claims, damages, expenses, and attorney fees arising out of, directly or indirectly, any claim relating to any noncompliance with the applicable laws and regulations, as well as any unintended or unauthorized application.

7. While efforts have been made to ensure the information contained in this document is accurate, complete and current, it may contain technical inaccuracies, omissions and typographical errors. Diodes does not warrant that information contained in this document is error-free and Diodes is under no obligation to update or otherwise correct this information. Notwithstanding the foregoing, Diodes reserves the right to make modifications, enhancements, improvements, corrections or other changes without further notice to this document and any product described herein. This document is written in English but may be translated into multiple languages for reference. Only the English version of this document is the final and determinative format released by Diodes.

8. Any unauthorized copying, modification, distribution, transmission, display or other use of this document (or any portion hereof) is prohibited. Diodes assumes no responsibility for any losses incurred by the customers or users or any third parties arising from any such unauthorized use.

9. This Notice may be periodically updated with the most recent version available at <https://www.diodes.com/about/company/terms-and-conditions/important-notice>

The Diodes logo is a registered trademark of Diodes Incorporated in the United States and other countries.

All other trademarks are the property of their respective owners.

© 2024 Diodes Incorporated. All Rights Reserved.

www.diodes.com