

Features

- Near-Zero propagation delay
- 5Ω switches connect inputs to outputs
- Direct bus connection when switches are ON
- Ultra-low quiescent power (0.2μA typical)
– Ideally suited for notebook applications
- Pin compatible with QS32X245
- Industrial operating temperature: -40°C to +85°C
- Packaging (Pb-free & Green available):
– 80-pin BQSOP (B)
– 80-pin DFN (ZA)

Description

Pericom Semiconductor's PI5C series of logic circuits are produced in the Company's advanced submicron CMOS technology.

The PI5C34X245 is a 32-bit, 2-port bus switch. Two enable signals ($\overline{BE}n$) turn the switches on. The bus switch creates no additional propagational delay or additional ground bounce noise.

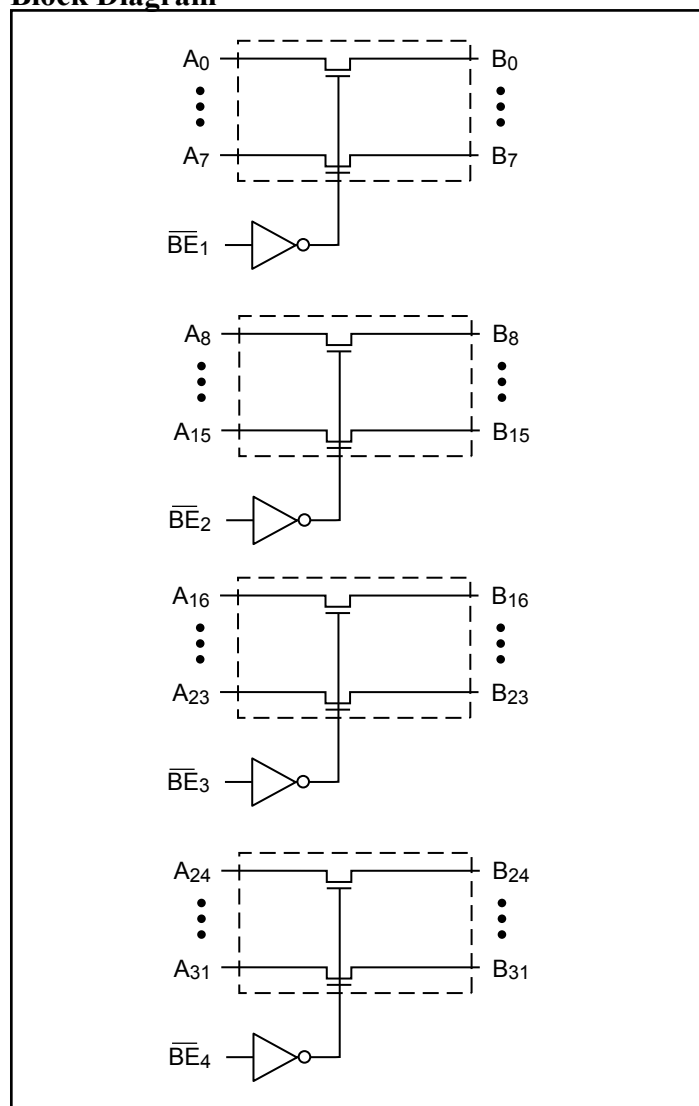
Block Diagram

Pin Configuration

NC	1	80	V _{CC}
A ₀	2	79	\overline{BE}_1
A ₁	3	78	B ₀
A ₂	4	77	B ₁
A ₃	5	76	B ₂
A ₄	6	75	B ₃
A ₅	7	74	B ₄
A ₆	8	73	B ₅
A ₇	9	72	B ₆
GND	10	71	B ₇
NC	11	70	V _{CC}
A ₈	12	69	\overline{BE}_2
A ₉	13	68	B ₈
A ₁₀	14	67	B ₉
A ₁₁	15	66	B ₁₀
A ₁₂	16	65	B ₁₁
A ₁₃	17	64	B ₁₂
A ₁₄	18	63	B ₁₃
A ₁₅	19	62	B ₁₄
GND	20	61	B ₁₅
NC	21	60	V _{CC}
A ₁₆	22	59	\overline{BE}_3
A ₁₇	23	58	B ₁₆
A ₁₈	24	57	B ₁₇
A ₁₉	25	56	B ₁₈
A ₂₀	26	55	B ₁₉
A ₂₁	27	54	B ₂₀
A ₂₂	28	53	B ₂₁
A ₂₃	29	52	B ₂₂
GND	30	51	B ₂₃
NC	31	50	V _{CC}
A ₂₄	32	49	\overline{BE}_4
A ₂₅	33	48	B ₂₄
A ₂₆	34	47	B ₂₅
A ₂₇	35	46	B ₂₆
A ₂₈	36	45	B ₂₇
A ₂₉	37	44	B ₂₈
A ₃₀	38	43	B ₂₉
A ₃₁	39	42	B ₃₀
GND	40	41	B ₃₁

Maximum Ratings

(Above which the useful life may be impaired. For user guidelines, not tested.)

Storage Temperature	-65°C to +150°C
Ambient Temperature with Power Applied	-40°C to +85°C
Supply Voltage to Ground Potential	-0.5V to +7.0V
DC Input Voltage	-0.5V to +7.0V
DC Output Current.....	120 mA
Power Dissipation	0.5W

Note:

Stresses greater than those listed under MAXIMUM RATINGS may cause permanent damage to the device. This is a stress rating only and functional operation of the device at these or any other conditions above those indicated in the operational sections of this specification is not implied. Exposure to absolute maximum rating conditions for extended periods may affect reliability.

Truth Table⁽¹⁾

Function	$\overline{B\overline{E}n}$	A0-A31
Disconnect	H	Hi-Z
Connect	L	B0-31

Note:

- H = High Voltage Level
L = Low Voltage Level
Hi-Z = High Impedance

Pin Description

Pin Name	I/O	Description
$\overline{B\overline{E}X}$	I	Bus Enable Input (Active LOW)
A0-A31	I/O	Bus A
B0-B31	I/O	Bus B

DC Electrical Characteristics (Over the Operating Range, $T_A = -40^\circ\text{C}$ to $+85^\circ\text{C}$, $V_{CC} = 5V \pm 10\%$)

Parameters	Description	Test Conditions ⁽¹⁾	Min.	Typ ⁽²⁾	Max.	Units
V_{IH}	Input HIGH Voltage	Guaranteed Logic HIGH Level	2.0	—	—	V
V_{IL}	Input LOW Voltage	Guaranteed Logic LOW Level	-0.5	—	0.8	
I_{IH}	Input HIGH Current	$V_{CC} = \text{Max.}, V_{IN} = V_{CC}$	—	—	± 1	μA
I_{IL}	Input LOW Current	$V_{CC} = \text{Max.}, V_{IN} = \text{GND}$	—	—	± 1	
I_{OZH}	High Impedance Output Current	0 - A, B - V_{CC}	—	—	± 1	
V_{IK}	Clamp Diode Voltage	$V_{CC} = \text{Min.}, I_{IN} = -18\text{mA}$	—	-0.7	-1.2	V
I_{OS}	Short Circuit Current ⁽³⁾	A (B) = 0V, B (A) = V_{CC}	100	—	—	mA
V_H	Input Hysteresis at Control Pins					
R_{ON}	Switch On-Resistance ⁽⁴⁾	$V_{CC} = \text{Min.}, V_{IN} = 0\text{V}, I_{ON} = 48\text{mA}$	—	5	7	Ω
		$V_{CC} = \text{Min.}, V_{IN} = 2.4\text{V}, I_{ON} = 15\text{mA}$	—	10	15	

Capacitance ($T_A = 25^\circ\text{C}$, $f = 1\text{ MHz}$)

Parameters ⁽⁵⁾	Description	Test Conditions	Max.	Units
C_{IN}	Input Capacitance	$V_{IN} = 0V$	6	pF
C_{OFF}	A/B Capacitance, Switch OFF		6	
C_{ON}	A/B Capacitance, Switch ON		12	

Notes:

- For Max. or Min. conditions, use appropriate value specified under Electrical Characteristics for the applicable device type.
- Typical values are at $V_{CC} = 5.0V$, $T_A = 25^\circ\text{C}$ ambient and maximum loading.
- Not more than one output should be shorted at one time. Duration of the test should not exceed one second.
- Measured by the voltage drop between A and B pin at indicated current through the switch. On-Resistance is determined by the lower of the voltages on the two (A,B) pins.
- This parameter is determined by device characterization but is not production tested.

Power Supply Characteristics

Parameters	Description	Test Conditions ⁽¹⁾		Min.	Typ ⁽²⁾	Max.	Units
I_{CC}	Quiescent Power Supply Current	$V_{CC} = \text{Max.}$	$V_{IN} = \text{GND}$ or V_{CC}	—	0.1	3.0	μA
ΔI_{CC}	Supply Current per Input @ TTL HIGH	$V_{CC} = \text{Max.}$	$V_{IN} = 3.4V^{(3)}$	—	—	2.5	mA
I_{CCD}	Supply Current per Input per MHz ⁽⁴⁾	$V_{CC} = \text{Max.}$, A & B Pins Open BEn = GND, Control Input Toggling 50% Duty Cycle		—	—	0.25	mA/ MHz

Notes:

- For Max. or Min. conditions, use appropriate value specified under Electrical Characteristics for the applicable device.
- Typical values are at $V_{CC} = 5.0V$, $+25^\circ\text{C}$ ambient.
- Per TTL driven input ($V_{IN} = 3.4V$, control inputs only); A and B pins do not contribute to I_{CC} .
- This current applies to the control inputs only and represent the current required to switch internal capacitance at the specified frequency. The A and B inputs generate no significant AC or DC currents as they transition. This parameter is not tested, but is guaranteed by design.

Switching Characteristics over Operating Range

Parameter	Description	Conditions ⁽¹⁾	PI5C34X245		Units
			Com.		
			Min.	Max.	
t_{PLH} t_{PHL}	Propagation Delay ^(2,3) AX to Bx, Bx to Ax	$C_L = 50\text{pF}$ $R_L = 500\Omega$		0.25	ns
t_{PZH} t_{PZL}	Bus Enable Time $\overline{\text{BEx}}$ to Ax or Bx		1.5	5.6	
t_{PHZ} t_{PLZ}	Bus Disable Time $\overline{\text{BEx}}$ to Ax or Bx		1.5	5.2	

Notes:

- See test circuit and waveforms.
- This parameter is guaranteed but not tested on Propagation Delays.
- The bus switch contributes no propagational delay other than the RC delay of the On-Resistance of the switch and the load capacitance. The time constant for the switch alone is of the order of 0.25ns for 50pF load. Since this time constant is much smaller than the rise/fall times of typical driving signals, it adds very little propagational delay to the system. Propagational delay of the bus switch when used in a system is determined by the driving circuit on the driving side of the switch and its interaction with the load on the driven side.

Packaging Mechanical: 80-Pin, 150 Mil Wide Plastic BQSOP (B)

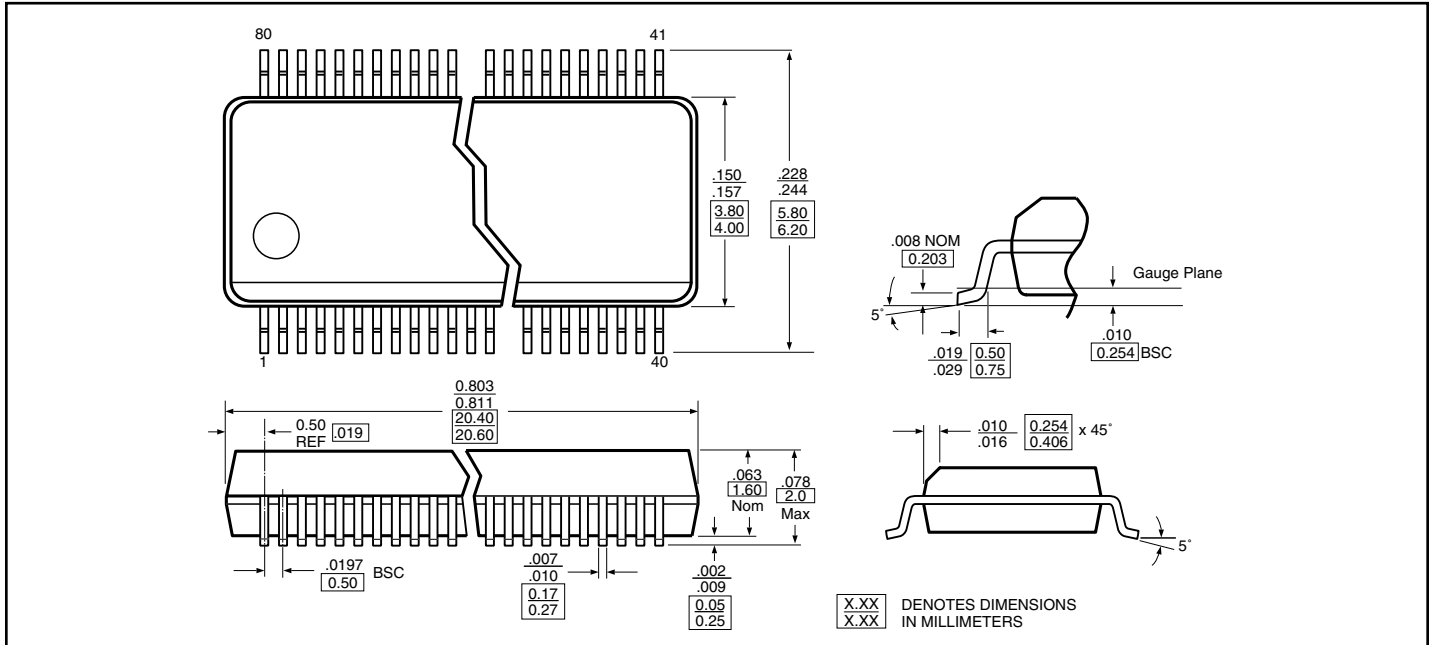

Packaging Mechanical: 80-Pin, Plastic Very Fine Pitch Dual Flat No-lead DFN (ZA)

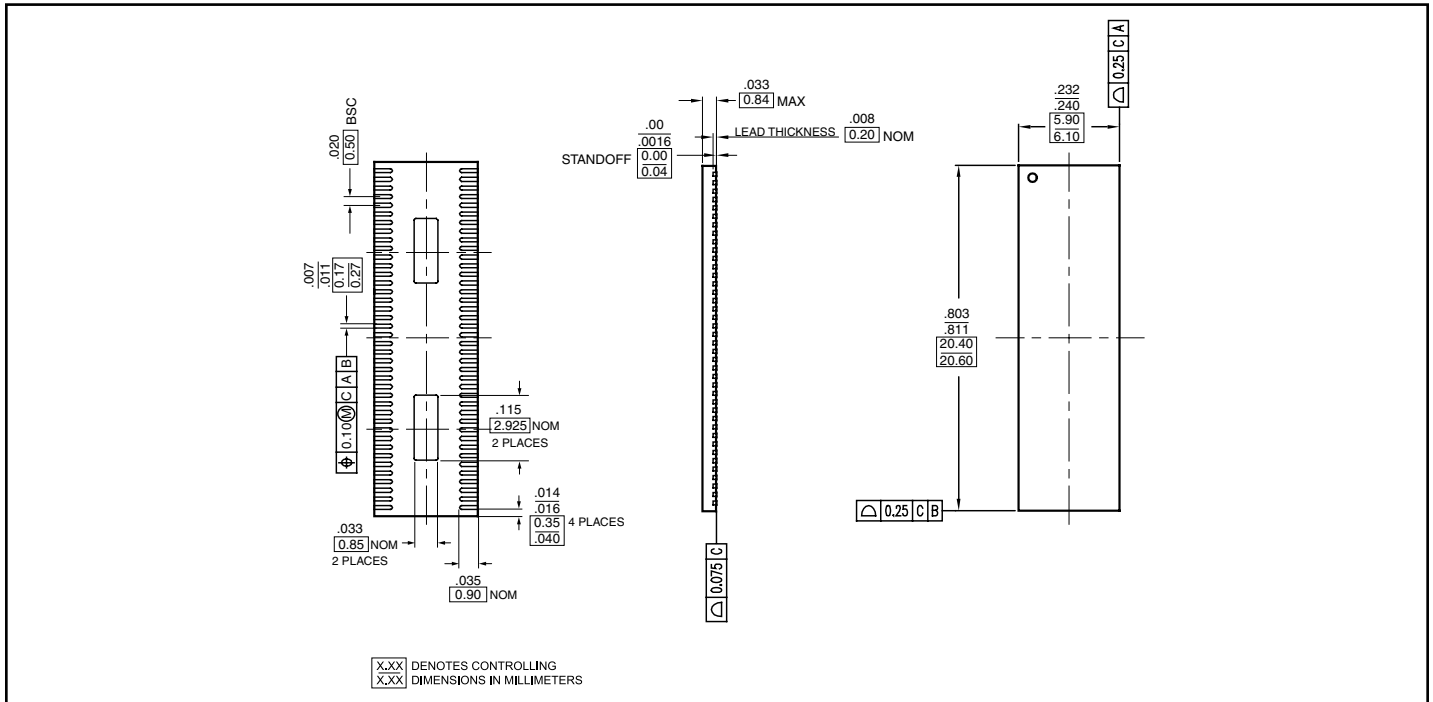

Ordering Information

Ordering Code	Packaging Code	Package Type
PI5C34X245B	B	80-Pin 150 Mil Wide Plastic BQSOP
PI5C34X245BE	B	Pb-free & Green, 80-Pin 150 Mil Wide Plastic BQSOP
PI5C34X245ZA	ZA	80-Pin Plastic Very Fine Pitch Dual Flat No lead (DFN)
PI5C34X245ZAE	ZA	Pb-free & Green, 80-Pin Plastic Very Fine Pitch Dual Flat No lead (DFN)

Notes:

1. This product has always shipped as only a lead free product, but since it was introduced prior to Pericom's strategy of adding an E to all Green/Lead free parts many customers order it without the E suffix. Please migrate new designs and qualification to include the E suffix. Pericom at this point in time will continue to offer devices marked both ways, but may at a later date eliminate the non-E part number.
2. Thermal characteristics can be found on the company web site at www.pericom.com/packaging/
3. Number of transistors = TBD