

**1.5V/1.8V/2.5V, 180MHz, 1:4 Networking Clock Buffer**
**Features**

- High-speed, low-noise, non-inverting 1:4 buffer
- Maximum Frequency up to 180 MHz
- Low output skew < 70ps (1.8V, 2.5V), <100ps (1.5V)
- Low propagation delay < 3.0ns (1.8V, 2.5V), <3.5ns (1.5V)
- Optimized duty cycle
- 1.5V - 2.5V supply voltage
- 3.3V Tolerant input clock
- Packages (Pb-free & Green available):  
-8-pin SOIC (W)

**Description**

The PI6C10804 is a 1.5V to 2.5V high-speed, low-noise 1:4 non-inverting clock buffer. The key goal in designing the PI6C10804 is to target networking applications that require low-skew, low-jitter, and high-frequency clock distribution.

Providing output-to-output skew as low as 70ps, the PI6C10804 is an ideal clock distribution device for synchronous systems. Designing synchronous networking systems requires a tight level of skew from a large number of outputs.

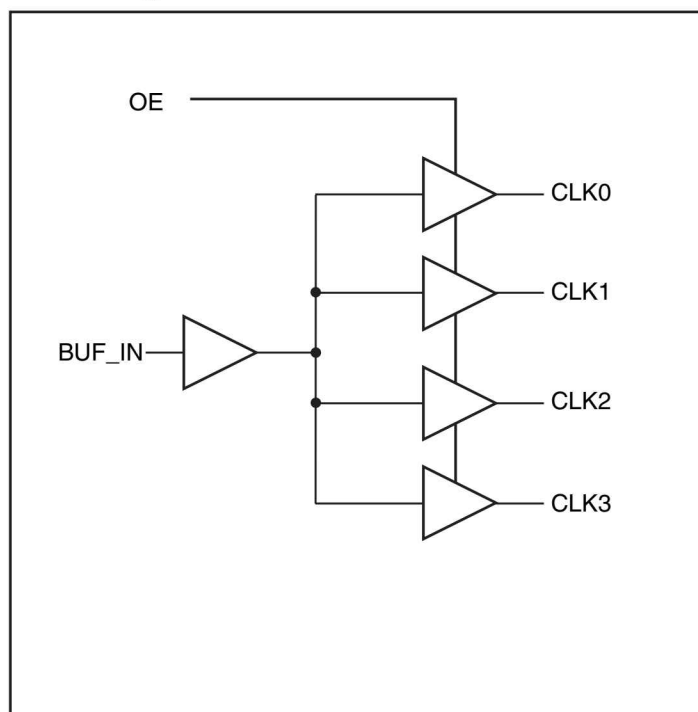
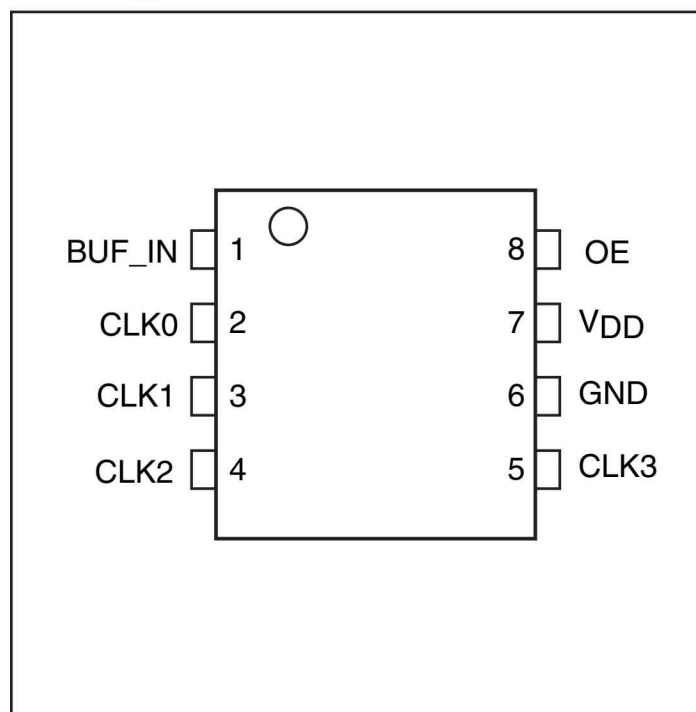
**Block Diagram**

**Pin Configuration**

**Pin Description**

Pin Name	Description
BUF_IN	Input
CLK [0:3]	Outputs
GND	Ground
VDD	Power
OE	Output Enable

**2.5V Absolute Maximum Ratings** (Above which the useful life may be impaired. For user guidelines only, not tested.)

Storage Temperature.....	-65°C to +150°C
V <sub>DD</sub> Voltage .....	-0.5V to +3.6V
Output Voltage.....	-0.5V to V <sub>DD</sub> +0.5V
Input Voltage .....	3.6V

**Note:**  
Stresses greater than those listed under MAXIMUM RATINGS may cause permanent damage to the device. This is a stress rating only and functional operation of the device at these or any other conditions above those indicated in the operational sections of this specification is not implied. Exposure to absolute maximum rating conditions for extended periods may affect reliability.

**2.5V DC Characteristics** (Over Operating Range: V<sub>DD</sub> = 2.5V ± 0.2V, T<sub>A</sub> = -40° to 85°C)

Parameters	Description	Test Conditions <sup>(1)</sup>	Min.	Typ. <sup>(2)</sup>	Max.	Units
V <sub>DD</sub>	Supply Voltage		2.3	2.5	2.7	V
V <sub>IH</sub>	Input HIGH Voltage	Logic HIGH level	1.7		3.6	V
V <sub>IL</sub>	Input LOW Voltage	Logic LOW level	-0.3		0.7	
I <sub>I</sub>	Input Current	V <sub>DD</sub> = Max, V <sub>IN</sub> = V <sub>DD</sub> or GND			15	μA
V <sub>OH</sub>	Output High Voltage	V <sub>DD</sub> = Min., V <sub>IN</sub> = V <sub>IH</sub> or V <sub>IL</sub>	I <sub>OH</sub> = -1mA	2.0		V
			I <sub>OH</sub> = -2mA	1.7		
			I <sub>OH</sub> = -8mA	1.5		
V <sub>OL</sub>	Output LOW Voltage	V <sub>DD</sub> = Min., V <sub>IN</sub> = V <sub>IH</sub> or V <sub>IL</sub>	I <sub>OL</sub> = 1mA		0.4	V
			I <sub>OL</sub> = 2mA		0.7	
			I <sub>OL</sub> = 8mA		0.7	

**Notes:**

- For Max. or Min. conditions, use appropriate operating range values.
- Typical values are at V<sub>DD</sub> = 2.5V, +25°C ambient and maximum loading.

**2.5V AC Characteristics** (Over Operating Range: V<sub>DD</sub> = 2.5V ± 0.2V, T<sub>A</sub> = -40° to 85°C)

Parameters	Description	Test Conditions <sup>(1)</sup>	Min.	Typ	Max.	Units
F <sub>IN</sub>	Input Frequency		0		250	MHz
t <sub>R</sub> /t <sub>F</sub>	CLKn Rise/Fall Time	20% to 80%			1	ns
t <sub>PLH</sub> , t <sub>PHL</sub> <sup>(2)</sup>	Propagation Delay BUF_IN to CLKn	C <sub>L</sub> = 5pF, 125 MHz Outputs are measured @ V <sub>DD</sub> /2	1.0	1.5	2.0	ns
t <sub>SK(O)</sub> <sup>(3)</sup>	Output to Output Skew between any two outputs of the same device @ same transition				70	ps
t <sub>SK(P)</sub> <sup>(3)</sup>	Pulse Skew between opposite transitions (t <sub>PHL</sub> -t <sub>PLH</sub> ) of the same output			100	200	
t <sub>SK(T)</sub> <sup>(3)</sup>	Part to Part Skew between two identical outputs of different parts on the same board <sup>(4)</sup>				300	
t <sub>dc in</sub>	Duty Cycle In @ 1ns edge rate		45		55	%
t <sub>dc out</sub>	Duty Cycle Out		40		60	

**Notes:**

- See test circuit and waveforms.
- Minimum limits are guaranteed but not tested on Propagation Delays.
- Skew measured at worse cast temperature (max. temp).
- Identical conditions: loading, transitions, supply voltage, temperature, package type and speed grade.

**1.8V Absolute Maximum Ratings** (Above which the useful life may be impaired. For user guidelines only, not tested.)

Storage Temperature.....	-65°C to +150°C
V <sub>DD</sub> Voltage .....	-0.5V to +2.5V
Output Voltage.....	-0.5V to V <sub>DD</sub> +0.5V
Input Voltage .....	3.6V

**Note:**  
 Stresses greater than those listed under MAXIMUM RATINGS may cause permanent damage to the device. This is a stress rating only and functional operation of the device at these or any other conditions above those indicated in the operational sections of this specification is not implied. Exposure to absolute maximum rating conditions for extended periods may affect reliability.

**1.8V DC Characteristics** (Over Operating Range: V<sub>DD</sub> = 1.8V ± 0.15V, T<sub>A</sub> = -40° to 85°C)

Parameters	Description	Test Conditions <sup>(1)</sup>	Min.	Typ. <sup>(2)</sup>	Max.	Units
V <sub>DD</sub>	Supply Voltage		1.65	1.8	1.95	V
V <sub>IH</sub>	Input HIGH Voltage	Logic HIGH level	0.65*V <sub>DD</sub>		3.6	
V <sub>IL</sub>	Input LOW Voltage	Logic LOW level	-0.3		0.35*V <sub>DD</sub>	
I <sub>I</sub>	Input Current <sup>(3)</sup>	V <sub>DD</sub> = Max, V <sub>IN</sub> = V <sub>DD</sub> or GND	I pin		15	μA
V <sub>OH</sub>	Output High Voltage	V <sub>DD</sub> = Min., V <sub>IN</sub> = V <sub>IH</sub> or V <sub>IL</sub>	I <sub>OH</sub> = -2mA	1.3		V
			I <sub>OH</sub> = -8mA	1.2		
V <sub>OL</sub>	Output LOW Voltage	V <sub>DD</sub> = Min., V <sub>IN</sub> = V <sub>IH</sub> or V <sub>IL</sub>	I <sub>OL</sub> = 2mA		0.45	
			I <sub>OL</sub> = -8mA		0.45	

**Notes:**

1. For Max. or Min. conditions, use appropriate operating V<sub>DD</sub> and T<sub>A</sub> values.
2. Typical values are at V<sub>DD</sub> = 1.8V, +25°C ambient and maximum loading.
3. This parameter is determined by device characterization but is not production tested.

**1.8V AC Characteristics** (Over Operating Range: V<sub>DD</sub> = 1.8V ± 0.15V, T<sub>A</sub> = -40° to 85°C)

Parameters	Description	Test Conditions <sup>(1)</sup>	Min.	Typ	Max.	Units	
F <sub>IN</sub>	Input Frequency		0		180	MHz	
t <sub>R</sub> /t <sub>F</sub>	CLKn Rise/Fall Time	20% to 80%			1	ns	
t <sub>PLH</sub> , t <sub>PHL</sub> <sup>(2)</sup>	Propagation Delay BUF_IN to CLKn	C <sub>L</sub> = 5pF, 125 MHz Outputs are measured @ V <sub>DD</sub> /2	1.0	2.0	3.0		
t <sub>SK(O)</sub> <sup>(3)</sup>	Output to Output Skew between any two outputs of the same device @ same transition				70	ps	
t <sub>SK(P)</sub> <sup>(3)</sup>	Pulse Skew between opposite transitions (t <sub>PHL</sub> -t <sub>PLH</sub> ) of the same output			200	275		
t <sub>SK(T)</sub> <sup>(3)</sup>	Part to Part Skew between two identical outputs of different parts on the same board <sup>(4)</sup>				300		
t <sub>dc in</sub>	Duty Cycle In @ 1ns edge rate			45		55	%
t <sub>dc out</sub>	Duty Cycle Out			40		60	

**Notes:**

1. See test circuit and waveforms.
2. Minimum limits are guaranteed but not tested on Propagation Delays.
3. Skew measured at worse cast temperature (max. temp).
4. Identical conditions: loading, transitions, supply voltage, temperature, package type and speed grade.

**Switching Characteristics** ( $V_{DD} = 2.5V \pm 0.2V$  or  $1.8V \pm 0.15V$ ,  $T_A = 105^\circ C$ )

Parameters	Description	Test Conditions	Min.	Typ.	Max.	Units
$t_{R,tF}$	CLKn Rise/Fall Time	20% to 80%, $C_L = 15pF$ , 125MHz		0.8	1.4	ns

Note: 1. All other AC and DC characteristics are identical to the 1.8V and 2.5V sections.

**1.5V Absolute Maximum Ratings** (Above which the useful life may be impaired. For user guidelines only, not tested.)

Storage Temperature.....	-65°C to +150°C
$V_{DD}$ Voltage .....	-0.5V to +2.6V
Output Voltage.....	-0.5V to $V_{DD}+0.5V$
Input Voltage .....	3.6V

**Note:**

Stresses greater than those listed under MAXIMUM RATINGS may cause permanent damage to the device. This is a stress rating only and functional operation of the device at these or any other conditions above those indicated in the operational sections of this specification is not implied. Exposure to absolute maximum rating conditions for extended periods may affect reliability.

**1.5V DC Characteristics** (Over Operating Range:  $V_{DD} = 1.5V \pm 0.075V$ ,  $T_A = -40^\circ$  to  $85^\circ C$ )

Parameters	Description	Test Conditions <sup>(1)</sup>	Min.	Typ. <sup>(2)</sup>	Max.	Units
$V_{DD}$	Supply Voltage		1.4	1.5	1.6	V
$V_{IH}$	Input HIGH Voltage	Logic HIGH level	1.17		3.6	
$V_{IL}$	Input LOW Voltage	Logic LOW level	-0.3		0.63	
$I_I$	Input Current	$V_{DD} = \text{Max}, V_{IN} = V_{DD}$ or GND			15	$\mu A$
$V_{OH}$	Output High Voltage	$V_{DD} = \text{Min.}, V_{IN} = V_{IH}$ or $V_{IL}$	$I_{OH} = -2mA$	1.05		V
			$I_{OH} = -8mA$	0.75		
$V_{OL}$	Output LOW Voltage	$V_{DD} = \text{Min.}, V_{IN} = V_{IH}$ or $V_{IL}$	$I_{OL} = 1mA$		0.4	
			$I_{OL} = 2mA$		0.35	
			$I_{OL} = 8mA$		0.35	

**Notes:**

- For Max. or Min. conditions, use appropriate operating range values.
- Typical values are at  $V_{DD} = 1.5V$ ,  $+25^\circ C$  ambient and maximum loading.

**1.5V AC Characteristics** (Over Operating Range:  $V_{DD} = 1.5V \pm 0.075V$ ,  $T_A = -40^\circ$  to  $85^\circ C$ )

Parameters	Description	Test Conditions <sup>(1)</sup>	Min.	Typ	Max.	Units
$F_{IN}$	Input Frequency		0		200	MHz
$t_{R/tF}$	CLKn Rise/Fall Time	20% to 80%			1.5	ns
$t_{PLH}, t_{PHL}$ <sup>(2)</sup>	Propagation Delay BUF_IN to CLKn	$C_L = 5pF$ , 125 MHz Outputs are measured @ $V_{DD}/2$	1.0	1.5	3.0	
$t_{SK(O)}$ <sup>(3)</sup>	Output to Output Skew between any two outputs of the same device @ same transition				100	ps
$t_{SK(T)}$ <sup>(3)</sup>	Part to Part Skew between two identical outputs of different parts on the same board <sup>(4)</sup>				300	
$t_{dc\_in}$	Duty Cycle In @ 1ns edge rate		45		55	%
$t_{dc\_out}$	Duty Cycle Out		40		60	

**Notes:**

- See test circuit and waveforms.
- Minimum limits are guaranteed but not tested on Propagation Delays.
- Skew measured at worse cast temperature (max. temp).
- Identical conditions: loading, transitions, supply voltage, temperature, package type and speed grade.



**Power Supply Characteristics**

Parameters	Description	Test Conditions <sup>(1)</sup>		Min.	Typ. <sup>(2)</sup>	Max.	Units
I <sub>DDQ</sub>	Quiescent Power Supply Current	V <sub>DD</sub> = 2.7V	V <sub>IN</sub> = GND or V <sub>DD</sub>			10	μA
		V <sub>DD</sub> = 1.95V				10	
I <sub>DD_TOT</sub>	Total Power Supply Current	V <sub>DD</sub> = 2.7V	All Outputs Toggling, C <sub>L</sub> = 5pF, F <sub>IN</sub> = 125MHz			20	mA
		V <sub>DD</sub> = 1.95V				15	
ΔI <sub>CC</sub>	Static Supply Current per inputs @ High Level	V <sub>DD</sub> = 2.7V	V <sub>INx</sub> = V <sub>DD</sub> - 0.6V <sup>(3)</sup>			200	μA
		V <sub>DD</sub> = 1.95V	V <sub>INx</sub> = V <sub>DD</sub> - 0.6V <sup>(3)</sup>			200	

**Notes:**

- For Max. or Min. conditions, use appropriate value specified under Electrical Characteristics.
- Typical values are at V<sub>DD</sub> = 1.8V or 2.5V, and +25°C ambient.
- Per TTL driven input (V<sub>IN</sub> = V<sub>DD</sub> - 0.6V); all other inputs at V<sub>DD</sub> or GND.

**Power Supply Characteristics**

Parameters	Description	Test Conditions <sup>(1)</sup>		Min.	Typ. <sup>(2)</sup>	Max.	Units
I <sub>DDQ</sub>	Quiescent Power Supply Current	V <sub>DD</sub> = 1.5V	V <sub>IN</sub> = GND or V <sub>DD</sub>			10	μA
I <sub>DD_TOT</sub>	Total Power Supply Current	V <sub>DD</sub> = 1.5V	All Outputs Toggling, C <sub>L</sub> = 5pF, F <sub>IN</sub> = 125MHz			15	mA

**Notes:**

- For Max. or Min. conditions, use appropriate value specified under Electrical Characteristics.
- Typical values are at V<sub>DD</sub> = 1.2V or 1.5V, and +25°C ambient.

**Capacitance** (T<sub>A</sub> = 25°C, f = 1 MHz)

Parameters <sup>(1)</sup>	Description	Test Conditions	Typ	Max.	Units
C <sub>IN</sub>	Input Capacitance	V <sub>IN</sub> = 0V	2.0	4	pF
C <sub>OUT</sub>	Output Capacitance	V <sub>OUT</sub> = 0V	1.7	6	

**Note:**

- This parameter is determined by device characterization but is not production tested.

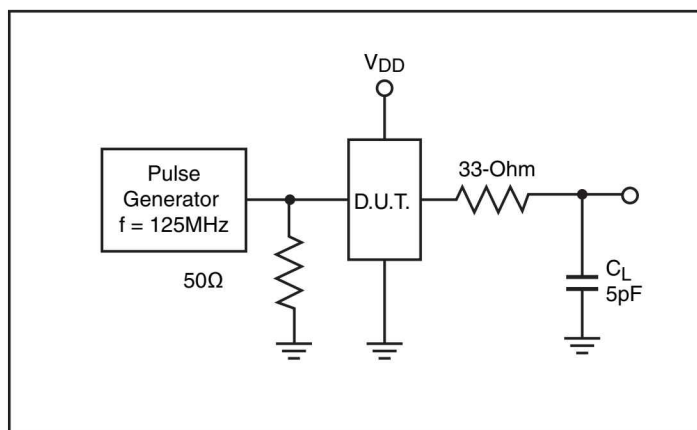
**Test Circuits for All Outputs**

**Definitions:**

C<sub>L</sub> = Load capacitance: includes jig and probe capacitance.

### Switching Waveforms

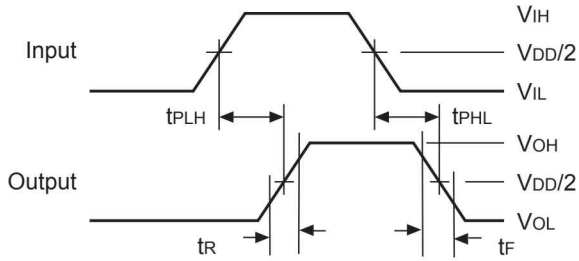
#### Propagation Delay



#### Pulse Skew – $t_{SK(P)}$

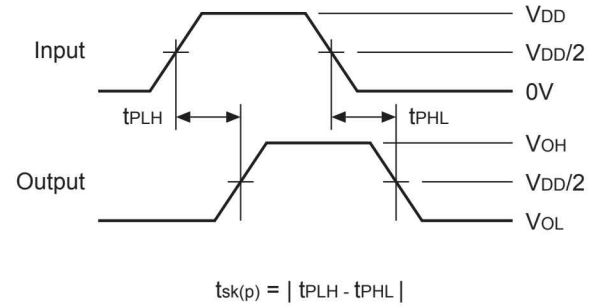

#### Output Skew – $t_{SK(O)}$

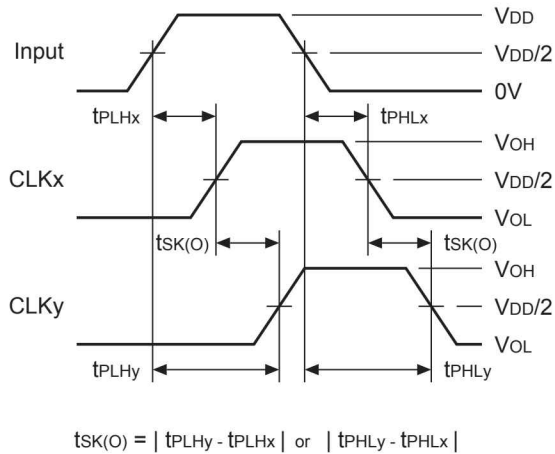

#### Package Skew – $t_{SK(T)}$

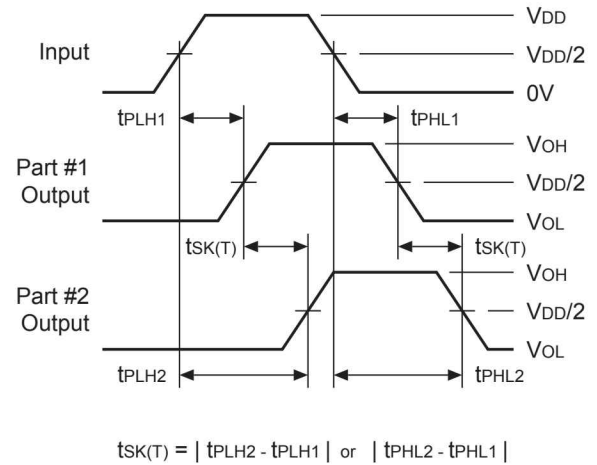

Packaging Mechanical: 8-Pin SOIC (W)

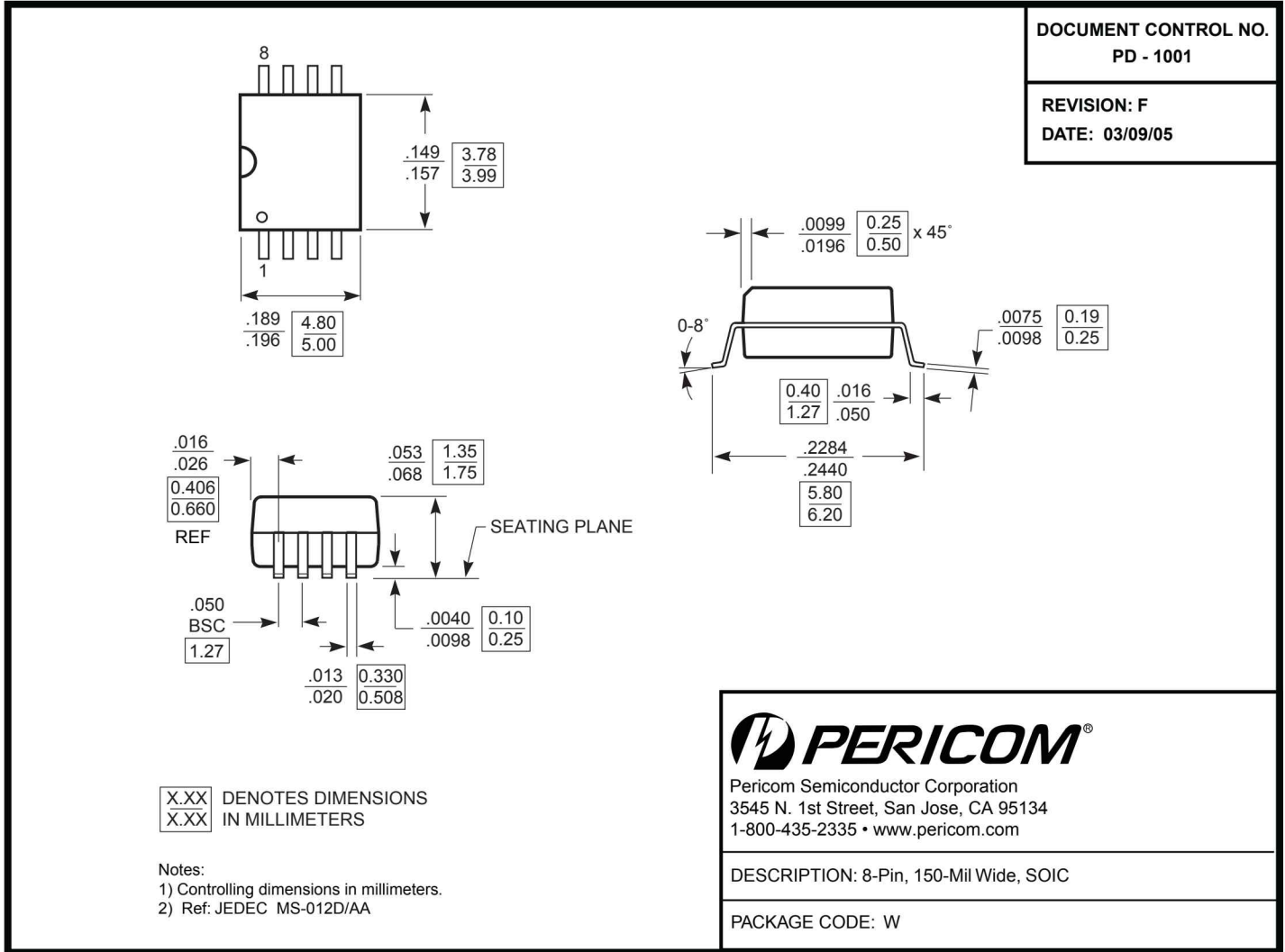

**Note:**

- For latest package info, please check: <http://www.pericom.com/products/packaging/mechanicals.php>

**Ordering Information(1,2,3)**

Ordering Code	Package Code	Package Type
PI6C10804WE	W	Pb-free & Green, 8-pin 153-mil wide SOIC

**Notes:**

1. Thermal Characteristics can be found on the web at [www.pericom.com/packaging/](http://www.pericom.com/packaging/)
2. E = Pb-free and Green
3. X suffix = Tape/Reel