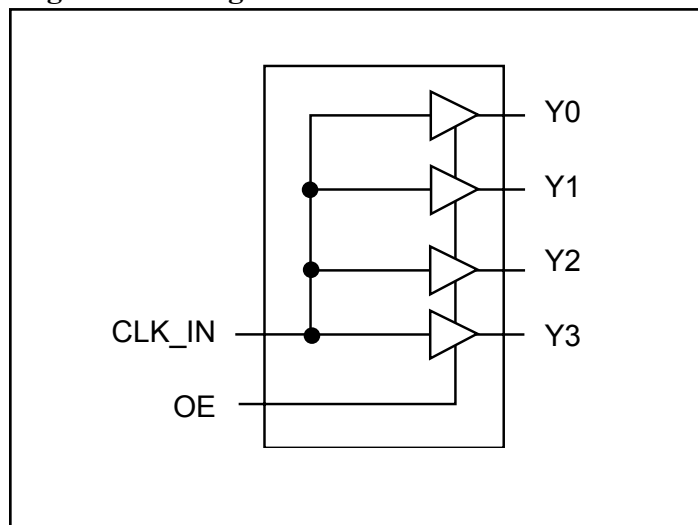

**Features**

- 160MHz maximum frequency
- Low skew: 250ps
- Fast rise/fall time: 1.5ns
- Output Enable with tri-states
- Industrial Temperature
- 3.3V or 5V power supply
- Packaging (Pb-free & Green available):  
–8-pin SOIC (W)

**Applications**

- 33MHz for PCI
- MHz for SDRAM
- 106.25MHz for Fibre Channel
- 125MHz for Ethernet
- 133MHz for PCIX
- 155.52MHz for OC3/SONET

**Logic Block Diagram**

**Description**

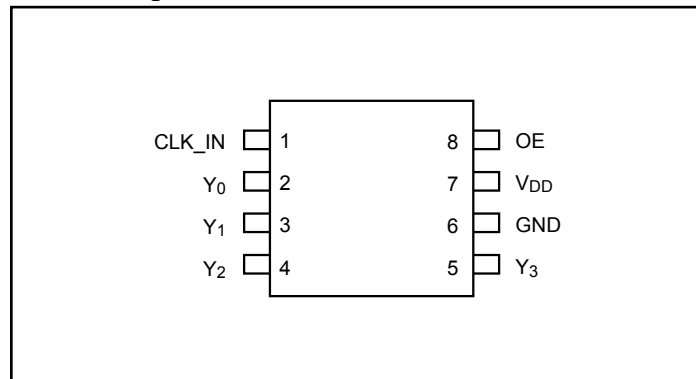
PI6C18551 is a low skew, low noise and high-speed clock buffer for computing, networking and communication applications. It is a non-inverting buffer with four outputs from a single input. The outputs are controlled by output enable pin (OE), outputs are tri-states when OE is LOW, and outputs are enabled when OE is HIGH.

**Pin Description**

**Function Table**

Inputs		Outputs
CLK_IN	OE	Y[3:0]
X	L	Z
L	H	L
H	H	H

**Note:**

1. X = Don't Care; Z = Tri-state

**Pin Description**

Pin Name	Type	Pin No	Descriptions
CLK_IN	Input	1	Input clock with pull-up resistor
Y0	Output	2	Output clock
Y1	Output	3	Output clock
Y2	Output	4	Output clock
Y3	Output	5	Output clock
GND	Ground	6	GROUND
V <sub>DD</sub>	Power	7	3.3V or 5V power supply
OE	Input	8	Output Enable with pull-up resistor

**External Components**

A minimum number of external components are required for proper operation. A decoupling capacitor of 0.01 $\mu$ F should be connected between V<sub>DD</sub> on pin 7 and GND on pin 6, as close to the device as possible. A 33 $\Omega$  series terminating resistor may be used on each clock output if the trace is longer than 1 inch.

**Absolute Maximum Ratings** (Over operating free-air temperature range)

Symbol	Parameters	Min.	Max.	Units
V <sub>DD</sub>	Supply Voltage		7	V
V <sub>I</sub>	Input Voltage	-0.5	V <sub>DD</sub> +0.5	
V <sub>O</sub>	Output Voltage	-0.5	V <sub>DD</sub> +0.5	
T <sub>s</sub>	Storage Temperature	-65	150	°C
T <sub>a</sub>	Ambient Temperature	-40	85	
T <sub>so</sub>	Soldering Temperature		260	

**DC Electrical Characteristics** ( $V_{DD} = 3.3V \pm 5\%$ ,  $T_A = -40$  to  $85^\circ C$ )

Symbol	Parameters	Condition	Min.	Typ.	Max.	Units
$V_{DD}$	3.3V I/O Supply Voltage		3.135		3.465	V
$V_{IH}$	Input High Voltage	CLK_IN, Note 1	$V_{DD}/2 + 0.7$		3.8	
		OE	2		$V_{DD}$	
$V_{IL}$	Input Low Voltage	CLK_IN, Note 1			$V_{DD}/2 - 0.7$	
		OE			0.8	
$V_{OH}$	Output High Voltage	$I_{OH} = -25mA$	2.4			
$V_{OL}$	Output Low Voltage	$I_{OL} = 25mA$			0.4	
$V_{OH}$	Output High Voltage (CMOS Level)	$I_{OH} = -12mA$	$V_{DD} - 0.4$			
$I_{DD}$	Power Supply Current	No load at 135MHz		18		mA
$Z_O$	Output Impedance			20		$\Omega$
$C_{IN}$	Input Capacitance	CLK_IN		TBD		pF
		OE		TBD		
$R_{PU}$	Internal Pull-up Resistor	CLK_IN & OE		120		k $\Omega$
$I_{OS}$	Short Circuit Current			$\pm 50$		mA

**Notes:**

- Nominal switching threshold is  $V_{DD}/2$

**DC Electrical Characteristics** ( $V_{DD} = 5V \pm 5\%$ ,  $T_A = -40$  to  $85^\circ\text{C}$ )

Symbol	Parameters	Condition	Min.	Typ.	Max.	Units
$V_{DD}$	5V I/O Supply Voltage		4.75		5.25	V
$V_{IH}$	Input High Voltage	CLK_IN, Note 1	$V_{DD}/2 + 1$		5.5	
		OE	2		$V_{DD}$	
$V_{IL}$	Input Low Voltage	CLK_IN, Note 1			$V_{DD}/2 - 1$	
		OE			0.8	
$V_{OH}$	Output High Voltage	$I_{OH} = -35\text{mA}$	2.4			
$V_{OL}$	Output Low Voltage	$I_{OL} = 35\text{mA}$			0.4	
$V_{OH}$	Output High Voltage (CMOS Level)	$I_{OH} = -12\text{mA}$	$V_{DD} - 0.4$			
$I_{DD}$	Power Supply Current	No load at 135MHz		35		mA
$Z_O$	Output Impedance			20		$\Omega$
$C_{in}$	Input Capacitance	CLK_IN		TBD		pF
		OE		TBD		
$R_{PU}$	Internal Pull-up Resistor	CLK_IN & OE		77		k $\Omega$
$I_{OS}$	Short Circuit Current			$\pm 80$		mA

**Notes:**

- Nominal switching threshold is  $V_{DD}/2$

**AC Electrical Characteristics** ( $V_{DD} = 3.3 \pm 5\%$ ,  $T_A = -40$  to  $85^\circ\text{C}$ )

Symbol	Parameters	Condition	Min.	Typ.	Max.	Units
$F_{in}$	Input Frequency		0		160	MHz
$F_o$	Output Frequency	3.3V, 15pF load <sup>(5)</sup>			160	
$F_o$	Output Frequency	5V, 15pF load <sup>(5)</sup>			135	
$T_R$	Rise Time	0.8V to 2.0V			1.5	ns
$T_F$	Fall Time	2.0V to 0.8V			1.5	
$T_{PD}$	Propagation Delay	3.3V, 135MHz <sup>(2)</sup>	2	4	8	
$T_{PD}$	Propagation Delay	5V, 135MHz <sup>(2)</sup>	1.5	3	6	
$T_{SK}$	Output Skew	$V_{DD}/2$ <sup>(3)</sup>			250	ps

**Notes:**

- With rail to rail input clock.
- All outputs with equal loading.
- Duty cycle on outputs will match incoming clock duty cycle.
- With external series resistor 33 $\Omega$  positioned close to each output pin.

Packaging Mechanical: 8-pin SOIC (W)

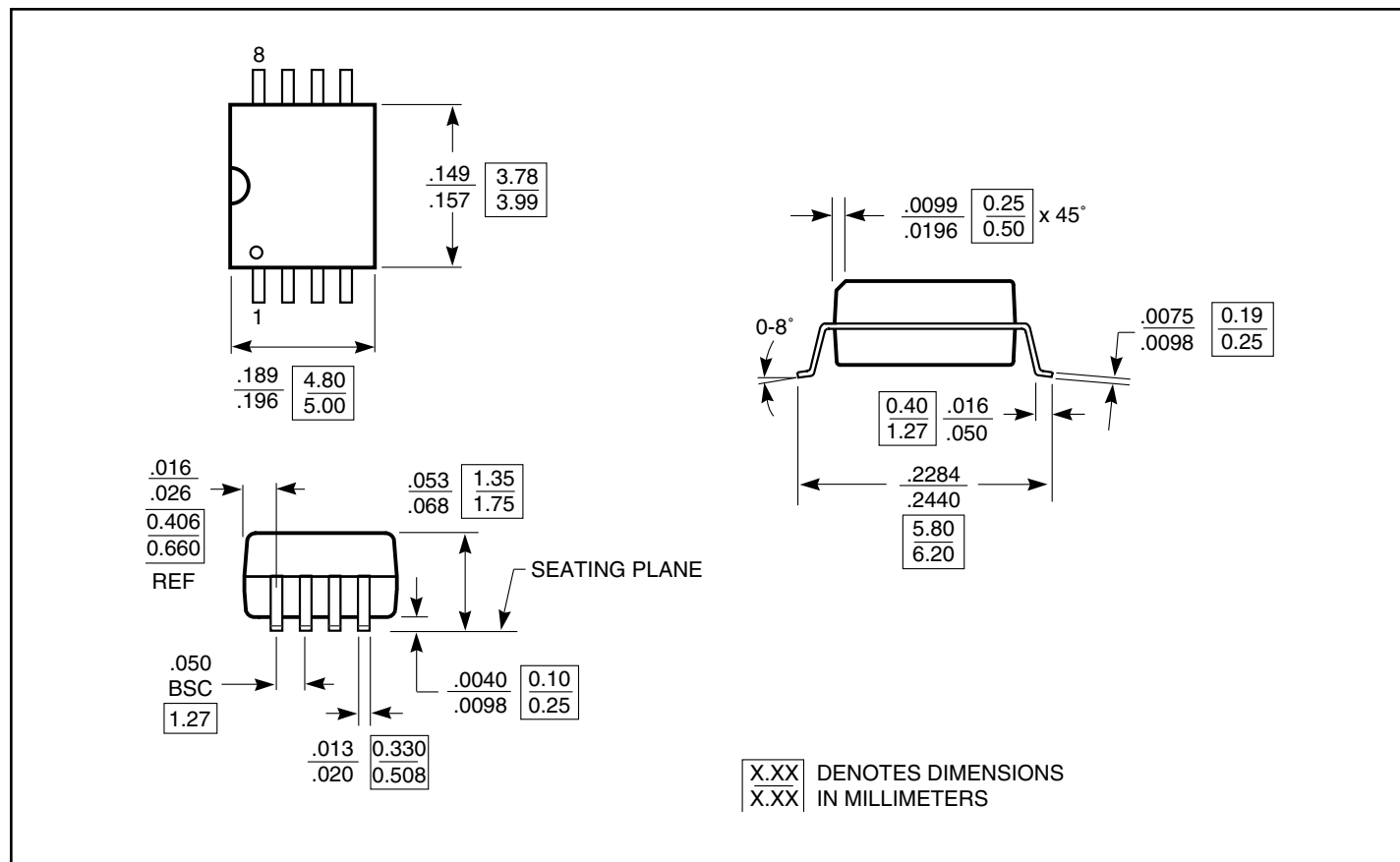

Ordering Information:

Ordering Code	Packaging Code	Package Type
PI6C18551W	W	8-pin SOIC
PI6C18551WE	W	Pb-free & Green, 8-pin SOIC

Notes:

1. Thermal characteristics can be found on the company web site at [www.pericom.com/packaging/](http://www.pericom.com/packaging/)