

3.3V Very-Low Power 4-Output PCIe Clock Generator With On-chip Termination

Features

- 3.3V Supply Voltage
- Crystal/CMOS Input: 25MHz
- Two Differential Low-Power HCSL Outputs with On-chip Termination
- Default $Z_{OUT} = 85\Omega$
- Individual Output Enable
- Reference CMOS Output
- Programmable Slew Rate and Output Amplitude for each Output
- Differential Outputs Blocked until PLL is Locked
- Selectable 0%, -0.25%, or -0.5% Spread on Differential Outputs
- Strapping pins or SMBus for Configuration
- 3.3V Tolerant SMBus Interface Support
- Very-Low Jitter Outputs
 - Differential Cycle-to-Cycle Jitter <50ps
 - Differential Output-to-Output Skew <50ps
 - PCIe Gen1/Gen2/Gen3/Gen4/Gen5 Compliant
 - CMOS REFOUT Phase Jitter is < 0.3ps RMS
- Totally Lead-Free & Fully RoHS Compliant (Notes 1 & 2)
- Halogen and Antimony Free. "Green" Device (Note 3)
- Packaging (Pb-free & Green): 32-lead 5mm × 5mm TQFN

Description

The PI6CG33402 is a four-output very-low-power PCIe Gen1/Gen2/Gen3/Gen4/Gen5 clock generator. It uses 25MHz crystal or CMOS reference as an input to generate the 100MHz low-power differential HCSL outputs with on-chip terminations. The on-chip termination can save 16 external resistors and make layout easier. An additional buffered reference output is provided to serve as a low-noise reference for other circuitry.

It uses Diodes' proprietary PLL design to achieve very-low jitter that meets PCIe Gen1/Gen2/Gen3/Gen4/Gen5 requirements. It also provides various options such as different slew rate and amplitude through SMBUS, so users can configure the device easily to get the optimized performance for their individual boards. The device also supports selectable spread-spectrum options to reduce EMI for various applications.

Block Diagram

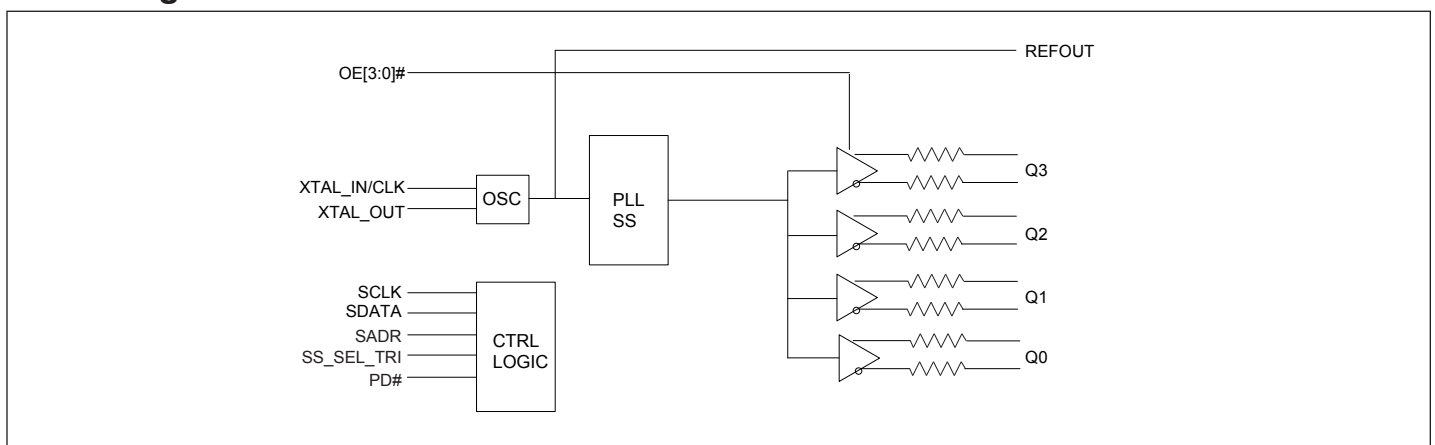

Notes:

1. No purposely added lead. Fully EU Directive 2002/95/EC (RoHS), 2011/65/EU (RoHS 2) & 2015/863/EU (RoHS 3) compliant.
2. See <https://www.diodes.com/quality/lead-free/> for more information about Diodes Incorporated's definitions of Halogen- and Antimony-free, "Green" and Lead-free.
3. Halogen- and Antimony-free "Green" products are defined as those which contain <900ppm bromine, <900ppm chlorine (<1500ppm total Br + Cl) and <1000ppm antimony compounds.

Pin Configuration

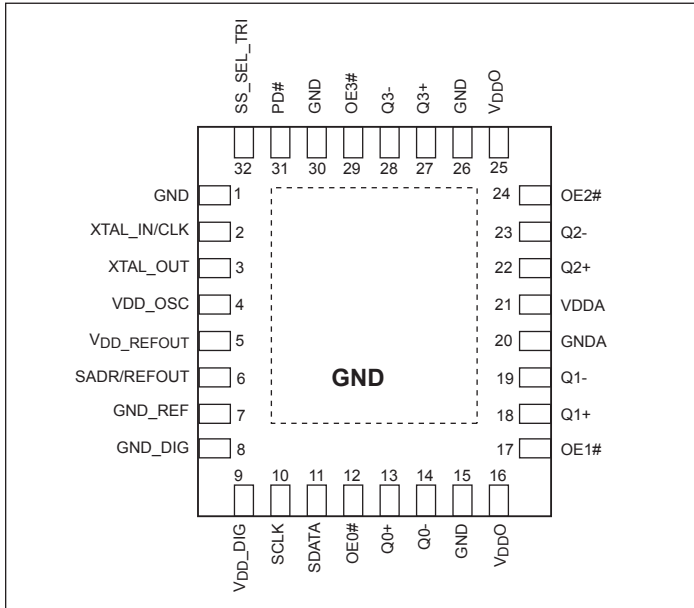

Pin Description

Pin #	Pin Name	Type		Description
1, 15, 26, 30	GND	Power	—	Ground pin
2	XTAL_IN/CLK	Input	—	Crystal input or CMOS reference input
3	XTAL_OUT	Output	—	Crystal output
4	VDD_OSC	Power	—	Power supply for oscillator circuitry, nominal 3.3V
5	VDD_REFOUT	Power	—	Power supply for buffered CMOS output
6	SADR/REFOUT	Input/ Output	CMOS	Latch to select SMBus Address or LVCMOS REFOUT. This pin has an internal pulldown
7	GND_REF	Power	—	Ground for REFOUT
8	GND_DIG	Power	—	Ground for digital circuitry
9	VDD_DIG	Power	—	Power supply for digital circuitry, nominal 3.3V
10	SCLK	Input	CMOS	SMBUS clock input, 3.3V tolerant
11	SDATA	Input/ Output	CMOS	SMBUS Data line, 3.3V tolerant
12	OE0#	Input	CMOS	Active low input for enabling Q0 pair. This pin has an internal pulldown. 1 =disable outputs, 0 = enable outputs
13	Q0+	Output	HCSL	Differential true clock output
14	Q0-	Output	HCSL	Differential complementary clock output
16, 25	VDDO	Power	—	Power supply for differential outputs

Pin Description Cont.

Pin #	Pin Name	Type		Description
17	OE1#	Input	CMOS	Active low input for enabling Q1 pair. This pin has an internal pulldown. 1 =disable outputs, 0 = enable outputs
18	Q1+	Output	HCSL	Differential true clock output
19	Q1-	Output	HCSL	Differential complementary clock output
20	GNDA	Power	—	Ground for analog circuitry
21	V _{DDA}	Power	—	Power supply for analog circuitry
22	Q2+	Output	HCSL	Differential true clock output
23	Q2-	Output	HCSL	Differential complementary clock output
24	OE2#	Input	CMOS	Active low input for enabling Q2 pair. This pin has an internal pulldown. 1 =disable outputs, 0 = enable outputs
27	Q3+	Output	HCSL	Differential true clock output
28	Q3-	Output	HCSL	Differential complementary clock output
29	OE3#	Input	CMOS	Active low input for enabling Q3 pair. This pin has an internal pulldown. 1 =disable outputs, 0 = enable outputs
31	PD#	Input	CMOS	Input notifies device to sample latched inputs and start up on first high assertion. Low enters Power Down Mode, and subsequent high assertions exit Power Down Mode. This pin has internal pullup resistor.
32	SS_SEL_TRI	Input	Tri-level	Latched select input to select spread spectrum amount at initial power up. 1 = -0.5% spread, M = -0.25%, 0 = Spread Off
Epad	GND	Power	—	Connect to ground

SMBus Address Selection Table

	SADR	Address	+Read/Write Bit
State of SADR on first application of PD#	0	1101000	X
	1	1101010	X

Power Management Table

PD#	SMBus OE bit	OEn#	Qn+	Qn-	REFOUT
0	X	X	Low ¹	Low ¹	HiZ ²
1	1	0	Running	Running	Running
1	1	1	Disabled ¹	Disabled ¹	Running
1	0	X	Disabled ¹	Disabled ¹	Disabled ⁴

1. The output state is set by B11[1:0] (Low/Low default).

2. REF is Hi-Z until the 1st assertion of PD# high. After this, when PD# is low, REF is disabled. If Byte3, bit 5 = 1, REF is running.

3. Input High/Low defined at default values for device.

4. See SMBUs Byte 3, bit 4.

Maximum Ratings

(Above which useful life may be impaired. For user guidelines, not tested.)

Storage Temperature.....	-65°C to +150°C
Supply Voltage to Ground Potential, V_{DDxx}	-0.5V to +4.6V
Input Voltage	-0.5V to $V_{DD}+0.5V$, not exceed 4.6V
SMBus, Input High Voltage	3.6V
ESD Protection (HBM)	2000V
Max Junction Temperature	+125°C

Note: Stresses greater than those listed under MAXIMUM RATINGS may cause permanent damage to the device. This is a stress rating only and functional operation of the device at these or any other conditions above those indicated in the operational sections of this specification is not implied. Exposure to absolute maximum rating conditions for extended periods may affect reliability.

Operating Conditions

Temperature = T_A ; Supply voltages per normal operation conditions; See test circuits for the load conditions.

Symbol	Parameters	Conditions	Min.	Typ.	Max.	Units
V_{DDO} , V_{DDA} , V_{DD_OSC} , V_{DD_DIG} , $V_{DD_RE-FOUT}$	Power Supply Voltage	—	3.135	3.3	3.465	V
I_{DDA}	Analog Power Supply Current	All outputs active @ 100MHz	—	22	25	mA
I_{DD}	Power Supply Current	All V_{DD} , except V_{DDA} and V_{DDO} , All outputs active @ 100MHz	—	13	16	mA
I_{DDO}	IO Power Supply Current	V_{DDO} , All outputs active @ 100MHz	—	20	25	mA
I_{DDA_WL}	Analog Power Supply Wake-on-LAN ¹ Current	Q outputs off, REF output running	—	0.5	1	mA
I_{DD_WL}	Power Supply Wake-on-LAN ¹ Current	All V_{DD} , except V_{DDA} and V_{DDO} , Q outputs off, REF output running	—	3	6	mA
I_{DDO_WL}	Power Supply Wake-on-LAN ¹ Current for Outputs	Q outputs off, REF output running	—	1	2	mA
I_{DDA_PD}	Analog Power Supply Power Down ² Current	All outputs off	—	0.5	1	mA
I_{DDO_PD}	IO Power Down ² Current	All outputs off	—	1	2	mA
I_{DD_PD}	Power Supply Power Down ² Current	All outputs off	—	1	2	mA
T_A	Ambient Temperature	Industrial grade	-40	—	85	°C

Note:

1. Wake-on-LAN mode: PD# = '0' Byte 3, bit 5 = '1'.
2. Power down mode: PD# = '0' Byte 3, bit 5 = '0'.

PI6CG33402

Input Electrical Characteristics

Symbol	Parameters	Conditions	Min.	Typ.	Max.	Units
R _{pu}	Internal pull up resistance	—	—	120	—	KΩ
R _{dn}	Internal pull down resistance	—	—	120	—	KΩ
C _{XTAL}	Internal capacitance on X_IN and X_OUT pins	—	—	8	—	pF
L _{PIN}	Pin inductance	—	—	—	7	nH

Crystal Characteristic

Parameters	Description	Min.	Typ	Max.	Units
OSCmode	Mode of Oscillation	Fundamental			—
FREQ	Frequency	—	25	—	MHz
ESR ¹	Equivalent Series Resistance	—	—	50	Ω
C _{load}	Load Capacitance	—	8	—	pF
C _{shunt}	Shunt Capacitance	—	—	7	pF
—	Drive Level	—	—	300	μW

Note:

1. ESR value is dependent upon frequency of oscillation

SMBus Electrical Characteristics

Temperature = T_A; Supply voltages per normal operation conditions; See test circuits for the load conditions.

Symbol	Parameters	Conditions	Min.	Typ.	Max.	Units
V _{DDSMB}	Nominal Bus Voltage	—	2.7	—	3.6	V
V _{IHSMB}	SMBus Input High Voltage	SMBus, V _{DDSMB} = 3.3V	2.1	—	3.6	V
		SMBus, V _{DDSMB} < 3.3V	0.65 V _{DDSMB}	—	—	
V _{ILSMB}	SMBus Input Low Voltage	SMBus, V _{DDSMB} = 3.3V	—	—	0.6	V
		SMBus, V _{DDSMB} < 3.3V	—	—	0.6	
I _{SMBSINK}	SMBus Sink Current	SMBus at V _{OLSMB}	4	—	—	mA
V _{OLSMB}	SMBus Output Low Voltage	SMBus at I _{SMBSINK}	—	—	0.4	V
f _{MAXSMB}	SMBus Operating Frequency	Maximum frequency	—	—	400	kHz
t _{RMSB}	SMBus Rise Time	(Max V _{IL} - 0.15) to (Min V _{IH} + 0.15)	—	—	1000	ns
t _{FMSB}	SMBus Fall Time	(Min V _{IH} + 0.15) to (Max V _{IL} - 0.15)	—	—	300	ns

Spread Spectrum Characteristic

Temperature = T_A; Supply voltages per normal operation conditions; See test circuits for the load conditions.

Symbol	Parameters	Conditions	Min.	Typ.	Max.	Units
f _{MOD}	SS Modulation Frequency	Triangular modulation	30	31.8	33	kHz

LVC MOS DC Electrical Characteristics

Temperature = T_A ; Supply voltages per normal operation conditions; See test circuits for the load conditions

Symbol	Parameters	Conditions	Min.	Typ.	Max.	Units
V_{IH}	Input High Voltage	Single-ended inputs, except SMBus	0.75 V_{DD}	—	V_{DD} +0.3	V
V_{IM}	Input Mid Voltage	SS_SEL_TRI	$0.4V_{DD}$	$0.5V_{DD}$	$0.6V_{DD}$	V
V_{IL}	Input Low Voltage	Single-ended inputs, except SMBus	-0.3	—	0.25 V_{DD}	V
I_{IH}	Input High Current	Single-ended inputs, $V_{IN} = V_{DD}$	—	—	5	μA
I_{IL}	Input Low Current	Single-ended inputs, $V_{IN} = 0V$	-5	—	—	μA
I_{IH}	Input High Current	Single-ended inputs with pullup/pulldown resistor, $V_{IN} = V_{DD}$	—	—	50	μA
I_{IL}	Input Low Current	Single-ended inputs with pullup/pulldown resistor, $V_{IN} = 0V$	-50	—	—	μA
V_{OH}	Output High Voltage	REFOUT, except SMBus; $I_{OH} = -2mA$	$0.8 \times$ $V_{DD_}$ REFOUT	—	—	V
V_{OL}	Output Low Voltage	REFOUT, except SMBus; $I_{OH} = 2mA$	—	—	$0.2 \times$ $V_{DD_}$ REFOUT	V
R_{OUT}	CMOS Output Impedance	—	—	20	—	Ω
C_{IN}	Input Capacitance	—	1.5	—	5	pF

LVCMOS AC Characteristics

Temperature = T_A ; Supply voltages per normal operation conditions; See test circuits for the load conditions.

Symbol	Parameters	Conditions	Min.	Typ.	Max.	Units
f_{INPUT}	Input Frequency	XTAL_IN/CLK	—	25	—	MHz
t_{RIN}	Input Rise Time	Single-ended inputs	—	—	5	ns
t_{FIN}	Input fall time	Single-ended inputs	—	—	5	ns
t_{STAB}	Clock Stabilization	From power up and after input clock stabilization or deassertion of PD# to first clock	—	0.75	1.8	ms
t_{OELAT}	Output Enable Latency	Q start after OE# assertion Q stop after OE# deassertion	1	—	3	clocks
t_{PDLAT}	PD# Deassertion	Differential outputs enable after PD# deassertion	—	20	300	μs
t_{PERIOD}	REFOUT Clock Period	REFOUT, assume input is at 25MHz	—	40	—	ns
f_{ACC}	REFOUT Frequency Accuracy ¹	REFOUT, long term accuracy to input	—	0	—	ppm
t_{SLEW}	REFOUT Slew Rate ¹	Byte 3 = 1F, 20% to 80% of V_{DDREF}	0.9	1.4	2	V/ns
		Byte 3 = 5F, 20% to 80% of V_{DDREF}	1.5	2.4	3.2	V/ns
		Byte 3 = 9F, 20% to 80% of V_{DDREF}	2.0	3.0	3.8	V/ns
		Byte 3 = DF, 20% to 80% of V_{DDREF}	2.3	3.2	4	V/ns
t_{DC}	REFOUT Duty Cycle ¹	$V_T = V_{\text{DD}}/2V$, driven by a Xtal	45	50	55	%
t_{DCDIS}	REFOUT Duty Cycle Distortion	$V_T = V_{\text{DD}}/2V$, driven by an external source	-2	0	+2	%
t_{JITCC}	REFOUT Cycle-Cycle Jitter	$V_T = V_{\text{DD}}/2V$, driven by a Xtal	—	70	250	ps
t_{JITPH}	REFOUT Phase Jitter	12kHz to 5MHz, RMS, driven by a Xtal	—	0.16	0.3	ps
t_{JITN}	Noise Floor	1kHz offset, driven by a Xtal	—	-149	-135	dBc/Hz
		10kHz offset to Nyquist, driven by a Xtal	—	-158	-140	dBc/Hz

Note:

1. Guaranteed by design and characterization—not 100% tested in production.

HCSL Output Characteristics

Temperature = T_A; Supply voltages per normal operation conditions; See test circuits for the load conditions.

Symbol	Parameters	Condition	Min.	Typ.	Max.	Units
V _{OH}	Output Voltage High ¹	Statistical measurement on single-ended signal using oscilloscope math function	660	784	850	mV
V _{OL}	Output Voltage Low ¹		-150	—	150	mV
V _{OMAX}	Output Voltage Maximum ¹	Measurement on single-ended signal using absolute value	—	816	1150	mV
V _{OMIN}	Output Voltage Minimum ¹		-300	-42	—	mV
V _{OSWING}	Output Swing Voltage ^{1,2,3}	Scope averaging off	300	1634	—	mV
V _{OC}	Output Cross Voltage ^{1,2,4}	—	250	430	550	mV
DV _{OC}	V _{OC} Magnitude Change ^{1,2,5}	—	—	12	140	mV

Note:

1. At default SMBUS amplitude settings.
2. Guaranteed by design and characterization—not 100% tested in production.
3. Measured from differential waveform.
4. This one is defined as voltage where Q+ = Q- measured on a component test board and only applied to the differential rising edge.
5. The total variation of all V_{cross} measurements in any particular system. This is a subset of V_{cross_min/max} allowed.

HCSL Output AC Characteristics

Temperature = T_A; Supply voltages per normal operation conditions; See test circuits for the load conditions

Symbol	Parameters	Condition	Min.	Typ.	Max.	Units
f _{OUT}	Output Frequency	—	—	100	—	MHz
t _{RF}	Slew Rate ^{1,2,3}	Scope averaging on fast setting	3	4	5	V/ns
		Scope averaging on slow setting	1.5	3.5	4.5	V/ns
Dt _{RF}	Slew Rate Matching ^{1,2,4}	Scope averaging on	—	3	—	%
t _{DC}	Duty Cycle ^{1,2}	Measured differentially, PLL Mode	45	50	55	%
t _{SKEW}	Output Skew ^{1,2}	Averaging on, V _T = 50%	—	43	50	ps
t _{jC-c}	Cycle-to-Cycle Jitter ^{1,2}	—	—	42	50	ps

HCSSL Output AC Characteristics Cont.

Symbol	Parameters	Condition	Min.	Typ.	Max	Spec Limit	Units
t _{JPHASE}	Integrated Phase Jitter (RMS) ^{1,5,6}	PCIe Gen 1	10	20	30	86	ps
		PCIe Gen 2 Low Band, 10kHz < f < 1.5MHz	0.01	0.04	0.06	3.0	ps
		PCIe Gen 2 High Band, 1.5MHz < f < Nyquist (50MHz)	0.08	0.15	0.3	3.1	ps
		PCIe Gen3 Common Clock Architecture (PLL BW of 2-4 or 2-5MHz, CDR = 10MHz)	0.02	0.05	0.1	1.0	ps
		PCIe Gen3 Separate Reference No Spread (PLL BW of 2-4 or 2-5MHz, CDR = 10 MHz)	0.03	0.04	0.1	0.7	ps
		PCIe Gen 4 (PLL BW of 2-4 or 2-5MHz, CDR = 10MHz)	0.04	0.05	0.08	0.5	ps
		PCIe Gen 5 ⁷ (PLL BW of 500k to 1.8MHz. CDR = 20MHz)	0.01	0.02	0.05	0.15	ps

Note:

1. Guaranteed by design and characterization—not 100% tested in production.
2. Measured from differential waveform.
3. Slew rate is measured through the V_{swing} voltage range centered around differential 0V, within ±150mV window.
4. It is measured using a ±75mV window centered on the average cross point.
5. See <http://www.pcisig.com> for complete specs.
6. Sample size of at least 100k cycles. This can be extrapolated to 108ps pk-pk @ 1M cycles for a BER of 10⁻¹².
7. PCIe Gen 5 v0.9 specification.

PI6CG33402

Differential Output Clock Periods - Spread Spectrum Disabled ^{1, 2}

Center Freq. MHz	Measurement Window							Units
	1 clock	1 μ s	0.1 s	0.1 s	0.1 s	1 μ s	1 clock	
	-c2c jitter AbsPer Min	- SSC Short-term Avg. Min	-ppm Long-term Avg. min	0 ppm Period Nominal	+ppm Long-term Avg. max	+ SSC Short-term Avg. Max	-c2c jitter AbsPer Max	
100.00	9.94900		9.99900	10.00000	10.00100		10.05100	ns

Differential Output Clock Periods - Spread Spectrum Enabled ^{1, 2}

Center Freq. MHz	Measurement Window							Units
	1 clock	1 μ s	0.1 s	0.1 s	0.1 s	1 μ s	1 clock	
	-c2c jitter AbsPer Min	- SSC Short-term Avg. Min	-ppm Long-term Avg. min	0 ppm Period Nominal	+ppm Long-term Avg. max	+ SSC Short-term Avg. Max	-c2c jitter AbsPer Max	
99.75	9.94906	9.99906	10.02406	10.02506	10.02607	10.05107	10.10107	ns

Note:

1. Guaranteed by design and characterization—not 100% tested in production.
2. All long term accuracy and clock period specifications are guaranteed assuming REF is trimmed to 25MHz.

SMBus Serial Data Interface

PI6CG33402 is a slave-only device that supports block read and block write protocol using a single 7-bit address and read/write bit as shown below.

Read and write block transfers can be stopped after any complete byte transfer.

Address Assignment

A6	A5	A4	A3	A2	A1	A0	R/W
1	1	0	1	0	SADR	0	1/0

Note: SMBus address is latched on SADR pin

How to Write

1 bit	7 bits	1 bit	1 bit	8 bits	1 bit	8 bits	1 bit	8 bits	1 bit		8 bits	1 bit	1 bit
Start bit	Add.	W(0)	Ack	Beginning Byte location = N	Ack	Data Byte count = X	Ack	Beginning Data Byte (N)	Ack	Data Byte (N+X-1)	Ack	Stop bit

How to Read

1 bit	7 bits	1 bit	1 bit	8 bits	1 bit	1 bit	7 bits	1 bit	1 bit	8 bits	1 bit	8 bits	1 bit
Start bit	Address	W(0)	Ack	Beginning Byte location = N	Ack	Repeat Start bit	Address	R(1)	Ack	Data Byte count = X	Ack	Beginning Data Byte (N)	Ack

	8 bits	1 bit	1 bit
.....	Data Byte (N+X-1)	NAck	Stop bit

Byte 0: Output Enable Register ¹

Bit	Control Function	Description	Type	Power-up Condition	0	1
7	Reserved	—	—	0	See B11[1:0]	—
6	Reserved	—	—	0		—
5	Reserved	—	—	0		—
4	Reserved	—	—	0		—
3	Q3_OE	Q3 output enable	RW	1		Pin Control
2	Q2_OE	Q2 output enable	RW	1		Pin Control
1	Q1_OE	Q1 output enable	RW	1		Pin Control
0	Q0_OE	Q0 output enable	RW	1		Pin Control

Note:

1. A low on these bits will override the OE# pins and force the differential outputs to the state indicated by B11[1:0] (Low/Low default).

Byte 1: SS Spread Spectrum and Control Register

Bit	Control Function	Description	Type	Power-up Condition	0	1
7	SSENRB1	SS Enable Readback Bit1	R	Latch	'00' for SS_SEL_TRI = '0', '01' for SS_SEL_TRI = 'M', '11' for SS_SEL_TRI = '1'	
6	SSENRB0	SS Enable Readback Bit0	R	Latch		
5	SSEN_SWCTR	Enable SW control of SS	RW	0	Values in B1[7:6] control SS amount	Values in B1[4:3] control SS amount
4	SSENSW1	SS enable SW control Bit1	RW ¹	0	'00' = SS off, '01' = -0.25% SS, '10' = Reserved, '11' = -0.5% SS	
3	SSENSW0	SS enable SW control Bit0	RW ¹	0		
2	Reserved	—	—	1	—	—
1	Amplitude1	Control output amplitude	RW	1	'00' = 0.6V, '01' = 0.68V, '10' = 0.75V, '11' = 0.85V	
0	Amplitude0		RW	0		

Note:

1. Spread must be selected OFF or ON with the hardware latch pin. These bits should not be used to turn spread ON or OFF after power up. These bits can be used to change the spread amount, and B1[5] must be set to a 1 for these bits to have any effect on the part. If These bits are used to turn spread OFF or ON, the system will need to be reset.

Byte 2: Differential Output Slew Rate Control Register

Bit	Control Function	Description	Type	Power-up Condition	0	1
7	Reserved	—	—	1	—	—
6	Reserved	—	—	1	—	—
5	Reserved	—	—	1	—	—
4	Reserved	—	—	1	—	—
3	SLEWRATECTR_Q3	Control slew rate of Q3	RW	1	Slow setting	Fast setting
2	SLEWRATECTR_Q2	Control slew rate of Q2	RW	1	Slow setting	Fast setting
1	SLEWRATECTR_Q1	Control slew rate of Q1	RW	1	Slow setting	Fast setting
0	SLEWRATECTR_Q0	Control slew rate of Q0	RW	1	Slow setting	Fast setting

Byte 3: REF Control Register

Bit	Control Function	Description	Type	Power Up Condition	0	1
7	REFSLEWRATE	Slew rate control for REF	RW	0	'00' = 0.9V/ns '01' = 1.5V/ns, '10' = 2.1V/ns, '11' = 2.7V/ns	
6			RW	1		
5	REF_PDSTATE	Wake-on-Lan enable for REF	RW	0	REF = Disabled in PD state	REF = running in PD state
4	REF_OE	Output enable for REF	RW	1	REF = Disabled	REF = running
3	Reserved	—	—	1	—	—
2	Reserved	—	—	1	—	—
1	Reserved	—	—	1	—	—
0	Reserved	—	—	1	—	—

1. The disabled state depends on Byte11[1:0]. '00' = Low, '01'=HiZ, '10'=Low, '11'=High.

Byte 4: Reserved

Bit	Control Function	Description	Type	Power Up Condition	0	1
7:0	Reserved	—	—	0x40	—	—

Byte 5: Revision and Vendor ID Register

Bit	Control Function	Description	Type	Power Up Condition	0	1
7	RID3	Revision ID	R	0	rev = 0000	
6	RID2		R	0		
5	RID1		R	0		
4	RID0		R	0		
3	PVID3	Vendor ID	R	0	Diodes = 0011	
2	PVID2		R	0		
1	PVID1		R	1		
0	PVID0		R	1		

PI6CG33402

Byte 6: Device Type/Device ID Register

Bit	Control Function	Description	Type	Power-up Condition	0	1
7	DTYPE1	Device type	R	0	'00' = CG, '01' = ZDB, '10' = Reserve, '11' = NZDB	
6	DTYPE0		R	0		
5	DID5	Device ID	R	0	000100 binary, 04Hex	
4	DID4		R	0		
3	DID3		R	0		
2	DID2		R	1		
1	DID1		R	0		
0	DID0		R	0		

Byte 7: Byte Count Register

Bit	Control Function	Description	Type	Power-up Condition	0	1
7	Reserved	—	—	0	—	—
6	Reserved	—	—	0	—	—
5	Reserved	—	—	0	—	—
4	BC4	Byte count programming	RW	0	Writing to this register configures how many bytes are read back, default is 8 bytes	
3	BC3		RW	1		
2	BC2		RW	0		
1	BC1		RW	0		
0	BC0		RW	0		

Byte 8 and 9: Reserved

Bit	Control Function	Description	Type	Power-up Condition	0	1
7:0	Reserved	—	—	B8: 0x36 B9: 0x00	—	—

Byte 10: PD Restore

Bit	Control Function	Description	Type	Power-up Condition	0	1
7	Reserved	—	—	0	—	—
6	PD Restore	PD Restore to default configuration	RW	1	Clear PD Config	Keep PD Config
5:0	Reserved	—	—	0	—	—

PI6CG33402

Byte 11: Stop Control

Bit	Control Function	Description	Type	Power-up Condition	0	1
7:2	Reserved	—	—	0	—	—
1	STP1	True/ Compliment DIF Output Disable Sate	RW	0	00= Low/Low	10= High/Low
0	STP0		RW	0	01= HiZ/HiZ	11= Low/High

Byte 12: Impedance Control

Bit	Control Function	Description	Type	Power-up Condition	0	1
7	Q1_Zout1	Q1 Zout	RW	01	00 = Reserved 01 = 85Ω 10 = 100Ω 11 = Reserved	
6	Q1_Zout0	Q1 Zout	RW			
5	Reserved					
4	Reserved					
3	Q0_Zout1	Q0 Zout	RW			
2	Q0_Zout0	Q0 Zout	RW			
1	Reserved					
0	Reserved					

Byte 13: Impedance Control

Bit	Control Function	Description	Type	Power-up Condition	0	1
7	Reserved			01	00 = Reserved 01 = 85Ω 10 = 100Ω 11 = Reserved	
6	Reserved					
5	Q3_Zout1	Q3 Zout	RW			
4	Q3_Zout0	Q3 Zout	RW			
3	Q2_Zout1	Q2 Zout	RW			
2	Q2_Zout0	Q2 Zout	RW			
1	Reserved					
0	Reserved					

PI6CG33402

Byte 14: OE Termination Control

Bit	Control Function	Description	Type	Power-up Condition	0	1
7	OE1_term1	OE1 Pullup or down	RW	0	00=None	10= Pullup
6	OE1_term0	OE1 Pullup or down	RW	1	01= Pulldown	11=Pullup and Down
5	Reserved	—	—	0	—	—
4	Reserved	—	—	1	—	—
3	OE0_term1	OE0 Pullup or down	RW	0	00=None	10= Pullup
2	OE0_term0	OE0 Pullup or down	RW	1	01= Pulldown	11=Pullup and Down
1	Reserved	—	—	0	—	—
0	Reserved	—	—	1	—	—

Byte 15: OE Termination Control

Bit	Control Function	Description	Type	Power-up Condition	0	1
7	Reserved	—	—	0	—	—
6	Reserved	—	—	1	—	—
5	OE3_term1	OE3 Pullup or down	RW	0	00=None	10= Pullup
4	OE3_term0	OE3 Pullup or down	RW	1	01= Pulldown	11=Pullup and Down
3	OE2_term1	OE2 Pullup or down	RW	0	00=None	10= Pullup
2	OE2_term0	OE2 Pullup or down	RW	1	01= Pulldown	11=Pullup and Down
1	Reserved	—	—	0	—	—
0	Reserved	—	—	1	—	—

Byte 16: Power Good Termination Control

Bit	Control Function	Description	Type	Power-up Condition	0	1
7:2	Reserved	—	—	0x09	—	—
1	PWRGD_PD1	Clock Power Good and Power Down Pullup or Pulldown	RW	1	00=None	10= Pullup
0	PWRGD_PD0		RW	0	01= Pulldown	11=Pullup and Down

Byte 17: Reserved

Byte 18: Enable Pin Control

Bit	Control Function	Description	Type	Power-up Condition	0	1
7	Reserved	—	—	0	—	—
6	OE3_Enable	Sets Enable High or Low	RW	0	Enable = Low	Enable = High
5	OE2_Enable	Sets Enable High or Low	RW	0	Enable = Low	Enable = High
4	Reserved	—	—	0	—	—
3	OE1_Enable	Sets Enable High or Low	RW	0	Enable = Low	Enable = High
2	Reserved	—	—	0	—	—
1	OE0_Enable	Sets Enable High or Low	RW	0	Enable = Low	Enable = High
0	Reserved	—	—	0	—	—

Byte 19: Enable Pin Control

Bit	Control Function	Description	Type	Power-up Condition	0	1
7:1	Reserved	—	—	0	—	—
0	PWRGD_PD	PWRGD_PD Active via Pullup or Pulldown	RW	0	Power Down = Low	Power Down = High

Phase Noise Plots
100MHz HCSL Clock (12k to 20MHz)

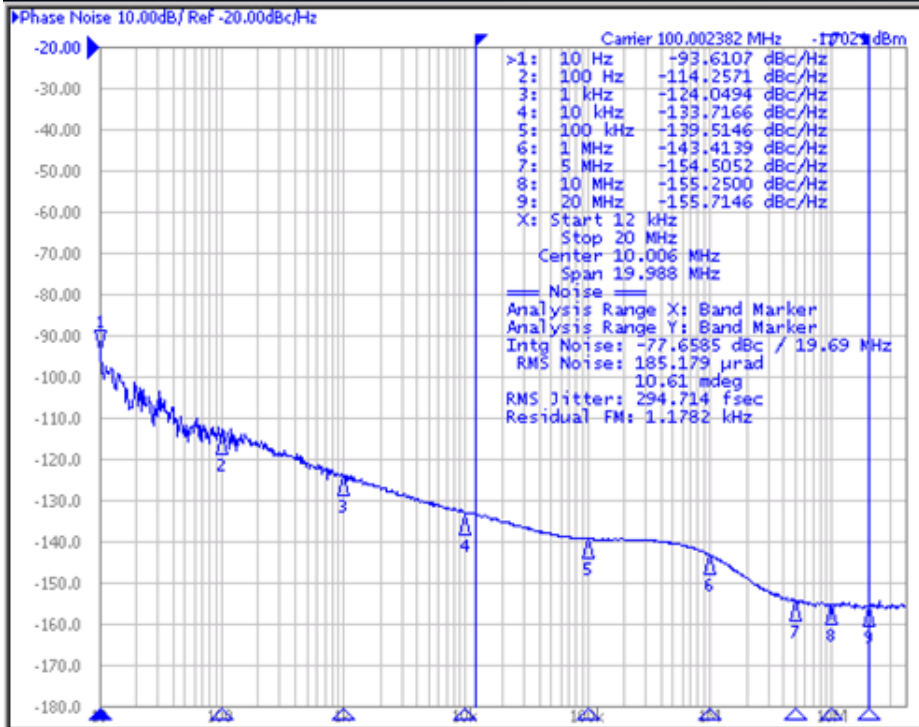

25MHz CMOS Clock

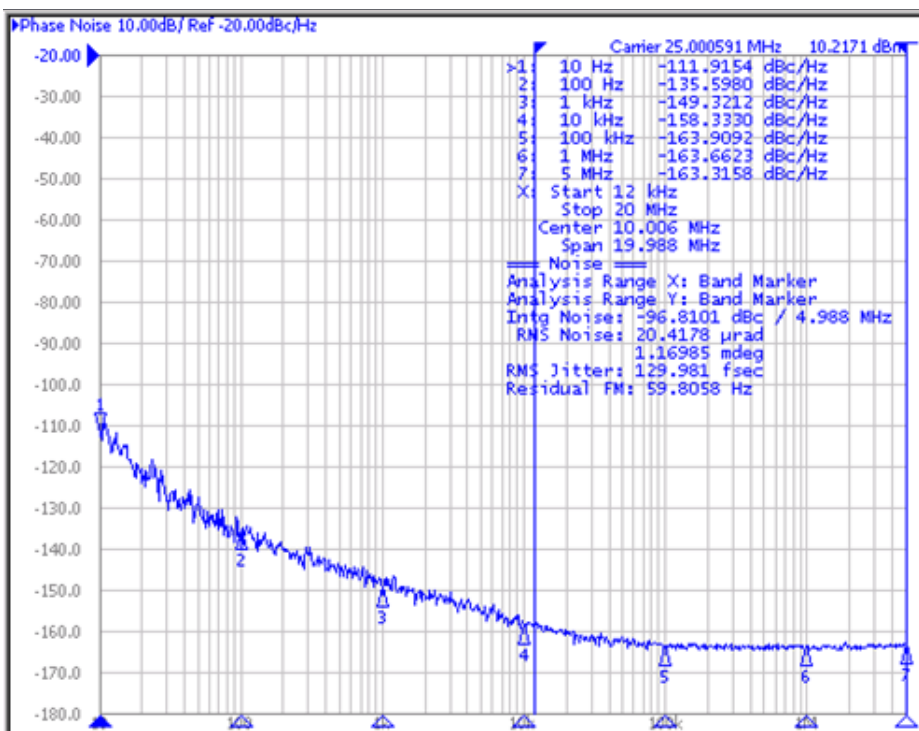

PI6CG33402

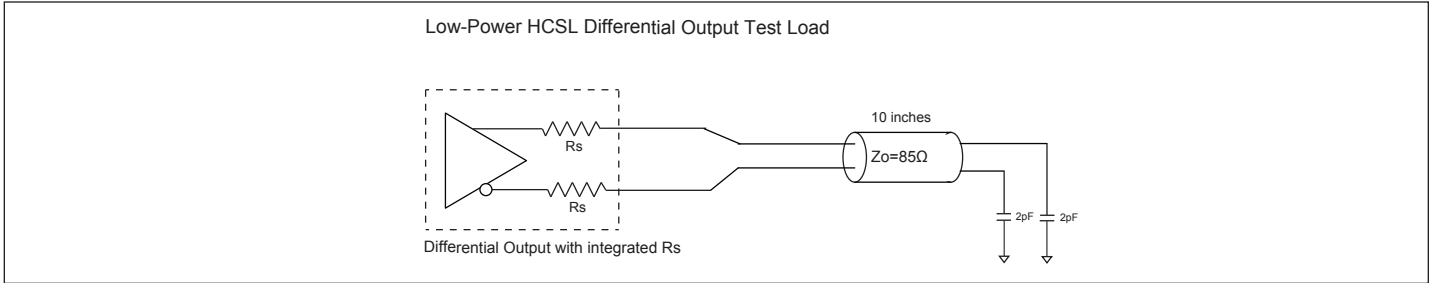

Figure 1. Low-Power HCSL Test Circuit

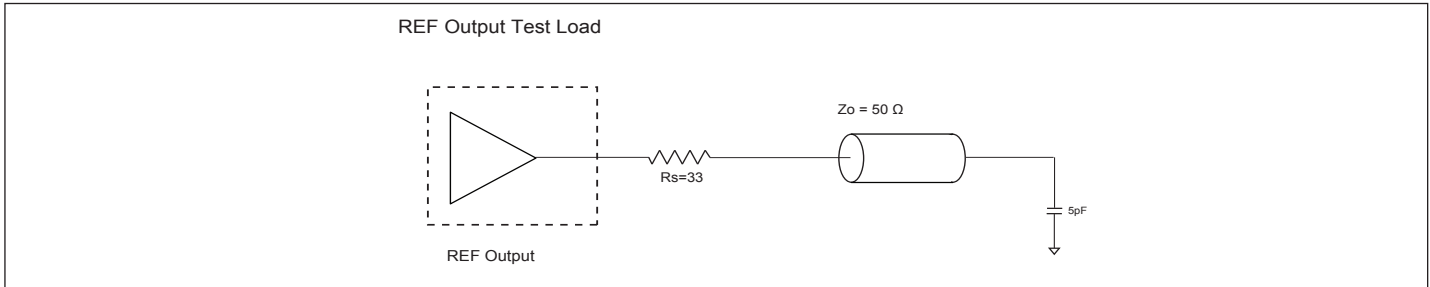

Figure 2. CMOS REF Test Circuit

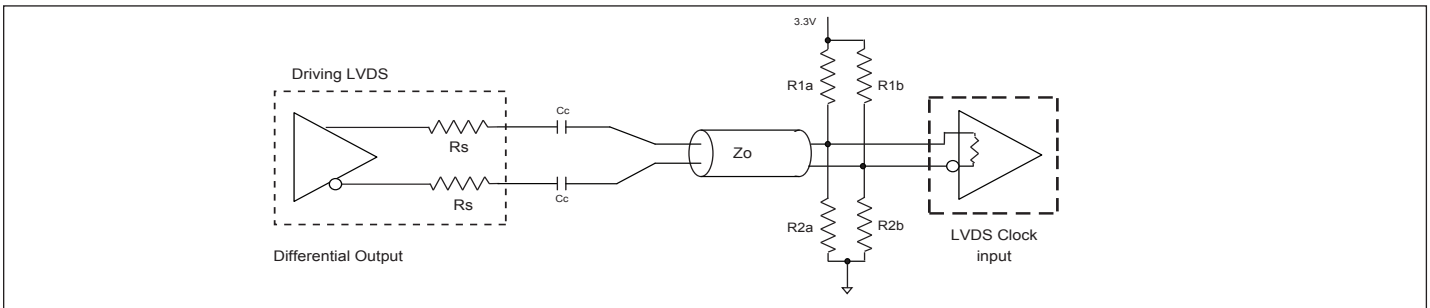

Figure 3. Differential Output Driving LVDS

Alternate Differential Output Terminations

Component	Receiver with Termination	Receiver without Termination	Unit
R _{1a} , R _{1b}	10,000	140	Ω
R _{2a} , R _{2b}	5600	75	Ω
C _C	0.1	0.1	μF
V _{CM}	1.2	1.2	V

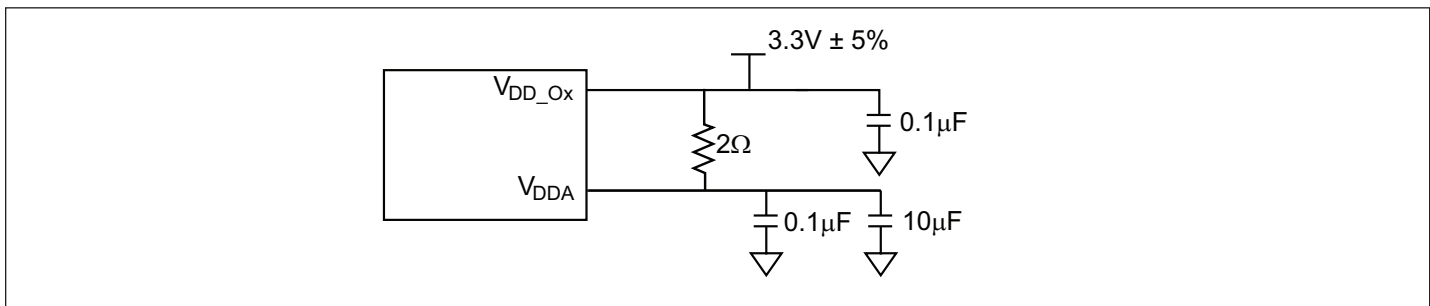
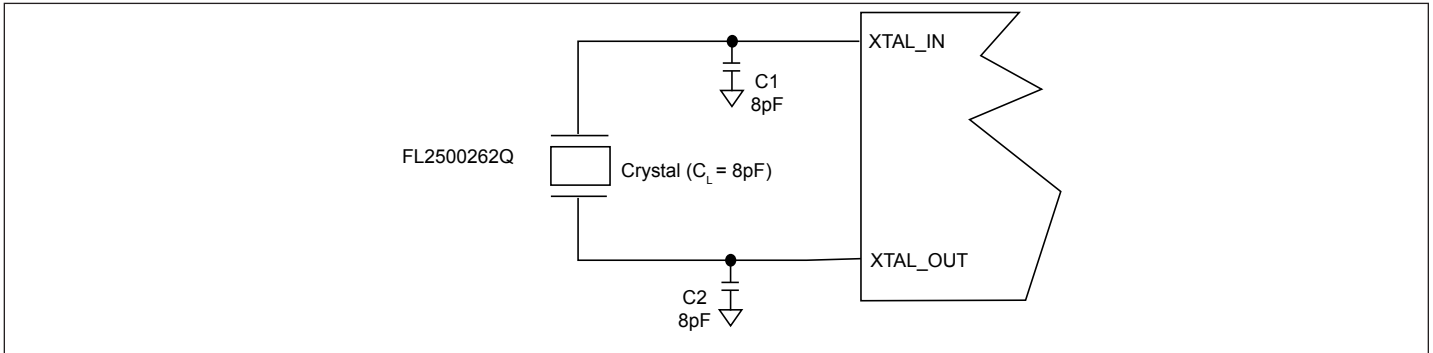

Figure 4. Power Supply Filter

Crystal Circuit Connection

The following diagram shows PI6CG33402 crystal circuit connection with a parallel crystal. For the $C_L = 8\text{pF}$ crystal, it is suggested to use $C_1 = 8\text{pF}$, $C_2 = 8\text{pF}$. C_1 and C_2 can be adjusted to fine tune to the target ppm of crystal oscillator according to different board layouts based on the following formula in the Crystal Capacitor Calculation diagram.

Crystal Oscillator Circuit



Crystal Capacitor Calculation

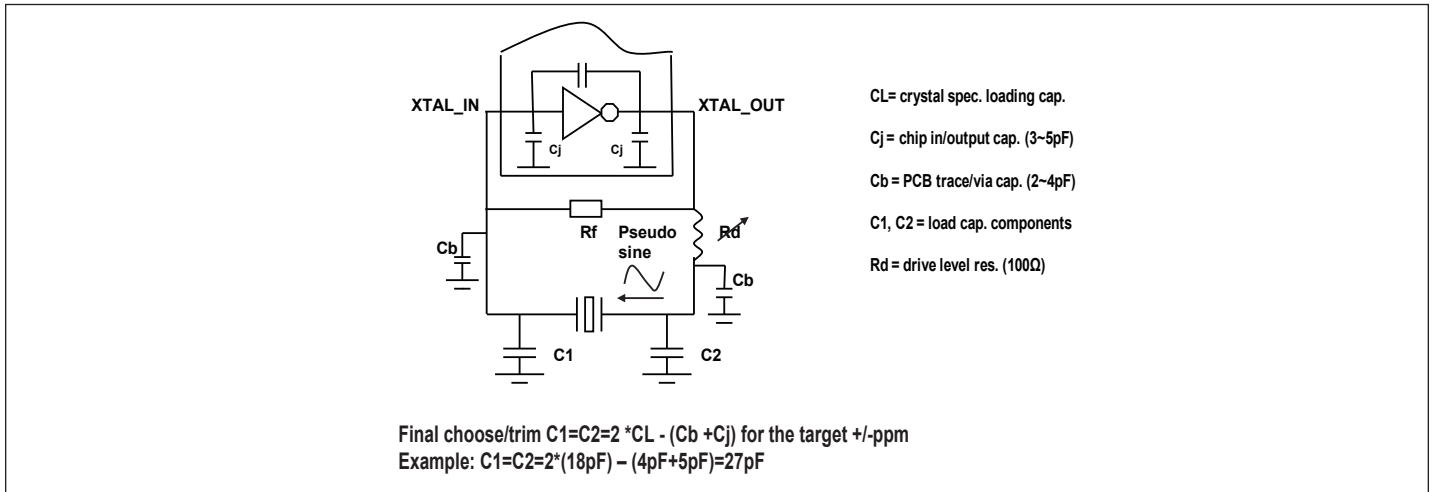

Recommended Crystal Specification

Diodes recommends:

- FL2500217, SMD 3.2x2.5(4P), 25MHz, $C_L=8\text{pF}$, +/-20ppm, <https://www.diodes.com/assets/Datasheets/FL.pdf>
- FH2500016, SMD 2.5x2.0(4P), 25MHz, $C_L=8\text{pF}$, +/-30ppm, <https://www.diodes.com/assets/Datasheets/FH.pdf>
- FW2500031, SMD 2.0x1.6(4P), 25MHz, $C_L=8\text{pF}$, +/-30ppm, <https://www.diodes.com/assets/Datasheets/FW.pdf>
- US2500003, SMD 1.6x1.2(4P), 25MHz, $C_L=12\text{pF}$, +/-30ppm, <https://www.diodes.com/assets/Datasheets/US.pdf>

Part Marking

Top mark not available at this time. To obtain advanced information regarding the top mark, contact your local sales representative.

PI6CG33402

Packaging Mechanical: 32-TQFN (ZH)

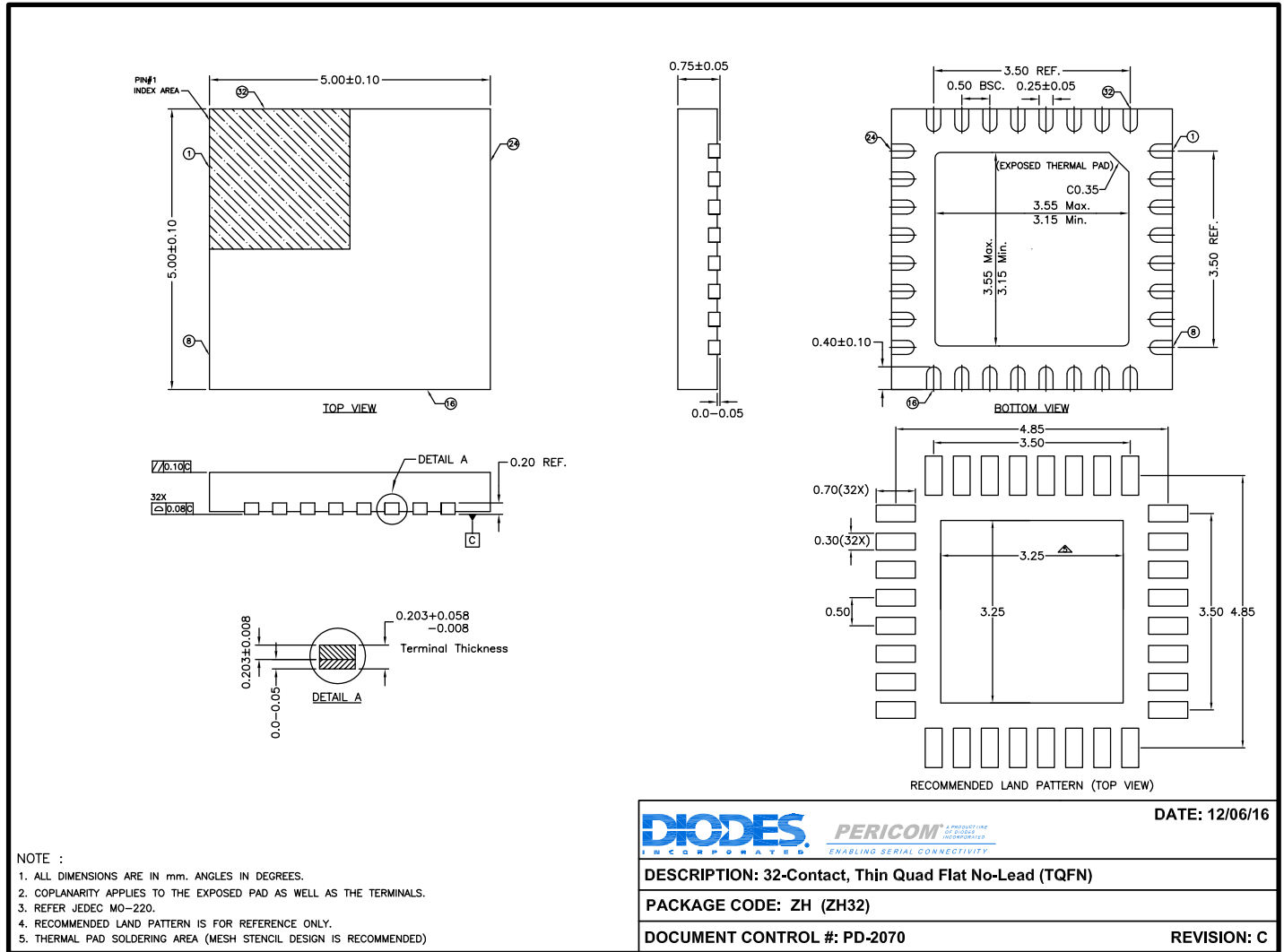

17-0570

For latest package information:

See <http://www.diodes.com/design/support/packaging/pericom-packaging/packaging-mechanicals-and-thermal-characteristics/>.

Ordering Information

Ordering Code	Package Code	Package Description	Operating Temperature
PI6CG33402ZHIEX	ZH	32-Contact, Thin Quad Flat No-Lead (TQFN)	Industrial

Notes:

- No purposely added lead. Fully EU Directive 2002/95/EC (RoHS), 2011/65/EU (RoHS 2) & 2015/863/EU (RoHS 3) compliant.
- See <https://www.diodes.com/quality/lead-free/> for more information about Diodes Incorporated's definitions of Halogen- and Antimony-free, "Green" and Lead-free.
- Halogen- and Antimony-free "Green" products are defined as those which contain <900ppm bromine, <900ppm chlorine (<1500ppm total Br + Cl) and <1000ppm antimony compounds.
- E = Pb-free and Green
- X suffix = Tape/Reel

IMPORTANT NOTICE

DIODES INCORPORATED MAKES NO WARRANTY OF ANY KIND, EXPRESS OR IMPLIED, WITH REGARDS TO THIS DOCUMENT, INCLUDING, BUT NOT LIMITED TO, THE IMPLIED WARRANTIES OF MERCHANTABILITY AND FITNESS FOR A PARTICULAR PURPOSE (AND THEIR EQUIVALENTS UNDER THE LAWS OF ANY JURISDICTION).

Diodes Incorporated and its subsidiaries reserve the right to make modifications, enhancements, improvements, corrections or other changes without further notice to this document and any product described herein. Diodes Incorporated does not assume any liability arising out of the application or use of this document or any product described herein; neither does Diodes Incorporated convey any license under its patent or trademark rights, nor the rights of others. Any Customer or user of this document or products described herein in such applications shall assume all risks of such use and will agree to hold Diodes Incorporated and all the companies whose products are represented on Diodes Incorporated website, harmless against all damages.

Diodes Incorporated does not warrant or accept any liability whatsoever in respect of any products purchased through unauthorized sales channel.

Should Customers purchase or use Diodes Incorporated products for any unintended or unauthorized application, Customers shall indemnify and hold Diodes Incorporated and its representatives harmless against all claims, damages, expenses, and attorney fees arising out of, directly or indirectly, any claim of personal injury or death associated with such unintended or unauthorized application.

Products described herein may be covered by one or more United States, international or foreign patents pending. Product names and markings noted herein may also be covered by one or more United States, international or foreign trademarks.

This document is written in English but may be translated into multiple languages for reference. Only the English version of this document is the final and determinative format released by Diodes Incorporated.

LIFE SUPPORT

Diodes Incorporated products are specifically not authorized for use as critical components in life support devices or systems without the express written approval of the Chief Executive Officer of Diodes Incorporated. As used herein:

A. Life support devices or systems are devices or systems which:

1. are intended to implant into the body, or

2. support or sustain life and whose failure to perform when properly used in accordance with instructions for use provided in the labeling can be reasonably expected to result in significant injury to the user.

B. A critical component is any component in a life support device or system whose failure to perform can be reasonably expected to cause the failure of the life support device or to affect its safety or effectiveness.

Customers represent that they have all necessary expertise in the safety and regulatory ramifications of their life support devices or systems, and acknowledge and agree that they are solely responsible for all legal, regulatory and safety-related requirements concerning their products and any use of Diodes Incorporated products in such safety-critical, life support devices or systems, notwithstanding any devices- or systems-related information or support that may be provided by Diodes Incorporated. Further, Customers must fully indemnify Diodes Incorporated and its representatives against any damages arising out of the use of Diodes Incorporated products in such safety-critical, life support devices or systems.

Copyright © 2019, Diodes Incorporated

www.diodes.com