

**20-Bit Buffer Driver  
with 3-STATE Outputs**
**Product Features**

- PI74ALVCH162827 is designed for low voltage operation
- $V_{CC} = 2.3V$  to  $3.6V$
- Hysteresis on all inputs
- Typical  $V_{OLP}$  (Output Ground Bounce)  
<  $0.8V$  at  $V_{CC} = 3.3V, T_A = 25^\circ C$
- Typical  $V_{OHV}$  (Output  $V_{OH}$  Undershoot)  
<  $2.0V$  at  $V_{CC} = 3.3V, T_A = 25^\circ C$
- Output ports have equivalent  $26\Omega$  series resistors;  
no external resistors are required
- Bus Hold retains last active bus state during 3-STATE,  
eliminating the need for external pullup resistors
- Industrial operation at  $-40^\circ C$  to  $+85^\circ C$
- Packages available:
  - 56-pin 240 mil wide plastic TSSOP (A)
  - 56-pin 300 mil wide plastic SSOP (V)

**Product Description**

Pericom Semiconductor's PI74ALVCH series of logic circuits are produced in the Company's advanced 0.5 micron CMOS technology, achieving industry leading speed.

The PI74ALVCH162827 is a 20-bit non-inverting buffer/driver designed for 2.3V to 3.6V  $V_{CC}$  operation.

The buffer/driver is composed of two 10-bit sections with separate output-enable signals. For either 10-bit buffer section, the two output-enable ( $1OE1$  and  $1OE2$  or  $2OE1$  and  $2OE2$ ) inputs must both be low for the corresponding Y outputs to be active. If either output-enable input is HIGH, the outputs of that 10-bit buffer section are in the high-impedance state.

The outputs, which are designed to sink up to 12mA, include  $26\Omega$  resistors to reduce overshoot and undershoot.

To ensure the high-impedance state during power up or power down,  $OE$  should be tied to  $V_{CC}$  through a pullup resistor; the minimum value of the resistor is determined by the current-sinking capability of the driver.

The PI74ALVCH162827 has "Bus Hold" which retains the data input's last state whenever the data input goes to high-impedance preventing "floating" inputs and eliminating the need for pullup/down resistors.

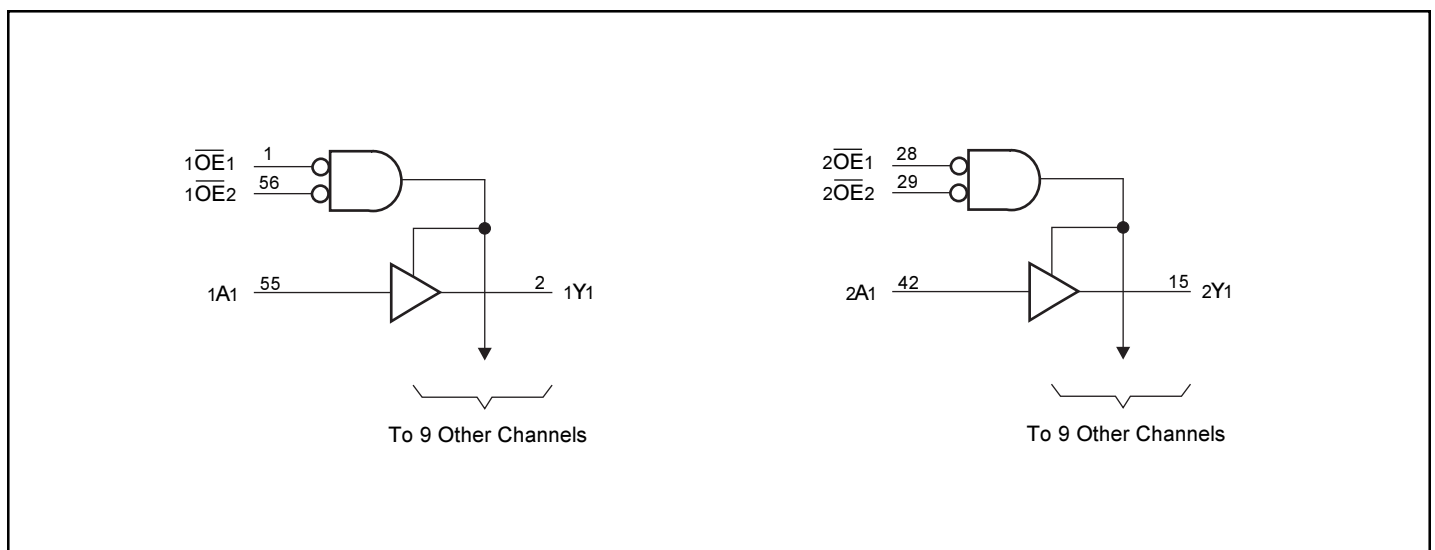
**Logic Block Diagram**

**Product Pin Description**

Pin Name	Description
$\overline{OE}$	Output Enable Input (Active LOW)
Ax	Data Inputs
Yx	3-State Outputs
GND	Ground
VCC	Power

**Truth Table<sup>(1)</sup>**

Inputs			Outputs
$\overline{OE1}$	$\overline{OE2}$	A	Y
L	L	L	L
L	L	H	H
H	X	X	Z
X	H	X	Z

www.DataSheet4U.com

**Notes:**

1. H = High Signal Level
- L = Low Signal Level
- X = Don't Care or Irrelevant
- Z = High Impedance

**Product Pin Configuration**

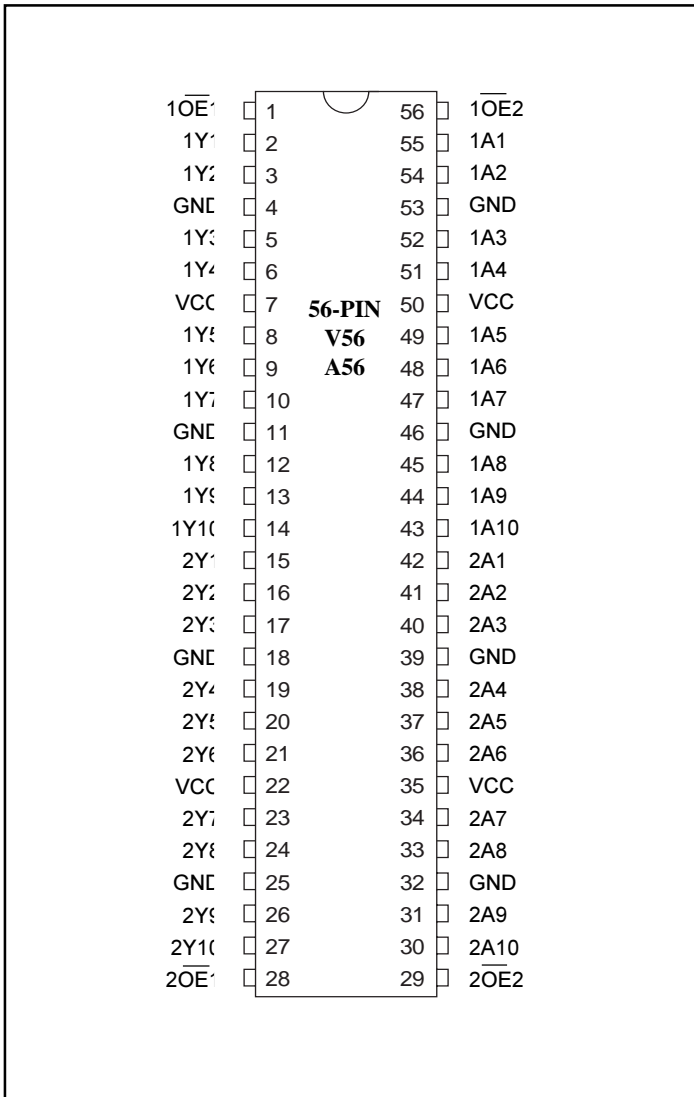

### Maximum Ratings

(Above which the useful life may be impaired. For user guidelines, not tested.)

Storage Temperature .....	-65°C to +150°C
Ambient Temperature with Power Applied .....	-40°C to +85°C
Input Voltage Range, $V_{IN}$ .....	-0.5V to $V_{CC} + 4.6V$
Output Voltage Range, $V_{OUT}$ .....	-0.5V to $V_{CC} + 0.5V$
DC Input Voltage .....	-0.5V to +5.0V
DC Output Current .....	50 mA
Power Dissipation .....	1.0W

**Note:**

Stresses greater than those listed under MAXIMUM RATINGS may cause permanent damage to the device. This is a stress rating only and functional operation of the device at these or any other conditions above those indicated in the operational sections of this specification is not implied. Exposure to absolute maximum rating conditions for extended periods may affect reliability.

### DC Electrical Characteristics (Over the Operating Range, $T_A = -40^\circ\text{C}$ to $+85^\circ\text{C}$ , $V_{CC} = 3.3V \pm 10\%$ )

Parameters	Description	Test Conditions <sup>(1)</sup>	Min.	Typ. <sup>(2)</sup>	Max.	Units
$V_{CC}$	Supply Voltage		2.3		3.6	V
$V_{IH}^{(3)}$	Input HIGH Voltage	$V_{CC} = 2.3V$ to $2.7V$	1.7			
		$V_{CC} = 2.7V$ to $3.6V$	2.0			
$V_{IL}^{(3)}$	Input LOW Voltage	$V_{CC} = 2.3V$ to $2.7V$			0.7	
		$V_{CC} = 2.7V$ to $3.6V$			0.8	
$V_{IN}^{(3)}$	Input Voltage		0		$V_{CC}$	
$V_{OUT}^{(3)}$	Output Voltage		0		$V_{CC}$	
$V_{OH}$	Output HIGH Voltage	$I_{OH} = -100\mu A$ , $V_{CC} = \text{Min. to Max.}$	$V_{CC} - 0.2$			
		$V_{IH} = 1.7V$ , $I_{OH} = -4mA$ , $V_{CC} = 2.3V$	1.9			
		$V_{IH} = 1.7V$ , $I_{OH} = -6mA$ , $V_{CC} = 2.3V$	1.7			
		$V_{IH} = 2.0V$ , $I_{OH} = -6mA$ , $V_{CC} = 2.7V$	2.4			
		$V_{IH} = 2.0V$ , $I_{OH} = -8mA$ , $V_{CC} = 3.0V$	2.0			
		$V_{IH} = 2.0V$ , $I_{OH} = -12mA$ , $V_{CC} = 3.0V$	2.0			
$V_{OL}$	Output LOW Voltage	$I_{OL} = 100\mu A$ , $V_{IL} = \text{Min. to Max.}$			0.2	
		$V_{IL} = 0.7V$ , $I_{OL} = 4mA$ , $V_{CC} = 2.3V$			0.4	
		$V_{IL} = 0.7V$ , $I_{OL} = 6mA$ , $V_{CC} = 2.3V$			0.55	
		$V_{IL} = 0.8V$ , $I_{OL} = 6mA$ , $V_{CC} = 2.7V$			0.55	
		$V_{IL} = 0.8V$ , $I_{OL} = 12mA$ , $V_{CC} = 3.0V$			0.8	
$I_{OH}^{(3)}$	Output HIGH Current	$V_{CC} = 2.3V$			-6	
		$V_{CC} = 2.7V$			-8	
		$V_{CC} = 3.0V$			-12	
$I_{OL}^{(3)}$	Output LOW Current	$V_{CC} = 2.3V$			6	
		$V_{CC} = 2.7V$			8	
		$V_{CC} = 3.0V$			12	

**DC Electrical Characteristics-Continued** (Over the Operating Range,  $T_A = -40^\circ\text{C}$  to  $+85^\circ\text{C}$ ,  $V_{CC} = 3.3\text{V} \pm 10\%$ )

Parameters	Description	Test Conditions <sup>(1)</sup>	Min.	Typ. <sup>(2)</sup>	Max.	Units
$I_{IN}$	Input Current	$V_{IN} = V_{CC}$ or GND, $V_{CC} = 3.6\text{V}$			$\pm 5$	$\mu\text{A}$
$I_{IN (HOLD)}$	Input Hold Current	$V_{IN} = 0.7\text{V}$ , $V_{CC} = 2.3\text{V}$	45			
		$V_{IN} = 1.7\text{V}$ , $V_{CC} = 2.3\text{V}$	-45			
		$V_{IN} = 0.8\text{V}$ , $V_{CC} = 3.0\text{V}$	75			
		$V_{IN} = 2.0\text{V}$ , $V_{CC} = 3.0\text{V}$	-75			
		$V_{IN} = 0$ to $3.6\text{V}$ , $V_{CC} = 3.6\text{V}$			$\pm 500$	
$I_{OZ}$	Output Current (3-STATE Outputs)	$V_{OUT} = V_{CC}$ or GND, $V_{CC} = 3.6\text{V}$			$\pm 10$	
$I_{CC}$	Supply Current	$V_{CC} = 3.6\text{V}$ , $I_{OUT} = 0\mu\text{A}$ , $V_{IN} = \text{GND}$ or $V_{CC}$			40	
$\Delta I_{CC}$	Supply Current per Input @ TTL HIGH	$V_{CC} = 3.0\text{V}$ to $3.6\text{V}$ One Input at $V_{CC} - 0.6\text{V}$ Other Inputs at $V_{CC}$ or GND			750	
$C_I$	Control Inputs	$V_{IN} = V_{CC}$ or GND, $V_{CC} = 3.3\text{V}$		3.5		pF
	Data Inputs			6		
$C_O$	Outputs	$V_O = V_{CC}$ or GND, $V_{CC} = 3.3\text{V}$		7		

**Notes:**

- For conditions shown as Max. or Min., use appropriate value specified under Electrical Characteristics for the applicable device type.
- Typical values are at  $V_{CC} = 3.3\text{V}$ ,  $+25^\circ\text{C}$  ambient and maximum loading.
- Unused Control Inputs must be held HIGH or LOW to prevent them from floating.

**Switching Characteristics over Operating Range<sup>(1)</sup>**

Parameters	From (INPUT)	To (OUTPUT)	$V_{CC} = 2.5\text{V} \pm 0.2\text{V}$		$V_{CC} = 2.7\text{V}$		$V_{CC} = 3.3\text{V} \pm 0.3\text{V}$		Units
			Min. <sup>(2)</sup>	Max.	Min. <sup>(2)</sup>	Max.	Min. <sup>(2)</sup>	Max.	
$t_{PD}$	A	Y	1.3	4.4		4.4	1.5	3.8	ns
$t_{EN}$	$\overline{\text{OE}}$	Y	1.5	7.2		6.2	1.6	5.2	
$t_{DIS}$	$\overline{\text{OE}}$	Y	2.4	5.9		5.2	1.8	4.7	
	<b>Description</b>								
$\Delta t/\Delta v^{(3)}$	Input Transition Rise or Fall		0	10	0	10	0	10	ns/V

**Notes:**

- See test circuit and waveforms.
- Minimum limits are guaranteed but not tested on Propagation Delays.
- Recommended operating condition.

**Operating Characteristics,  $T_A = 25^\circ\text{C}$** 

Parameter		Test Conditions	$V_{CC} = 2.5\text{V} \pm 0.2\text{V}$	$V_{CC} = 3.3\text{V} \pm 0.3\text{V}$	Units
			Typ.		
$C_{PD}$ Power Dissipation Capacitance	Outputs Enabled	$C_L = 50\text{pF}$ , $f = 10\text{MHz}$	16	18	pF
	Outputs Disabled		4	6	