

PI74ST1G32

SOTiny™ Gate ST 2-Input OR

Features

- High-speed: $t_{PD} = 1.8\text{ns}$ typical
- Broad operating range: $V_{CC} = 1.8\text{V} - 3.6\text{V}$
- Power down high-impedance inputs/outputs
- High output drive: $\pm 24\text{mA}$ at $3\text{V } V_{CC}$
- Package: 5-pin space saving SOT23 and SC70

Description

The PI74ST1G32 is a 2-input OR gate that operates over the 1.8V to 3.6V V_{CC} operating range.

Pericom's PI74ST series of products are produced using the Company's advanced submicron technology.

Pinout

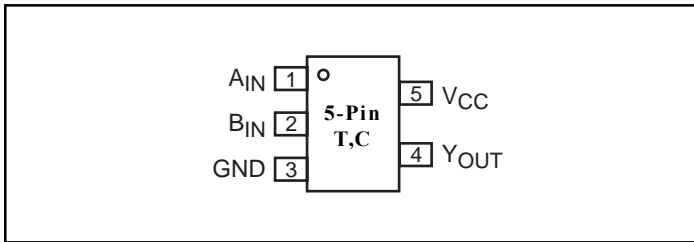

Block Diagram

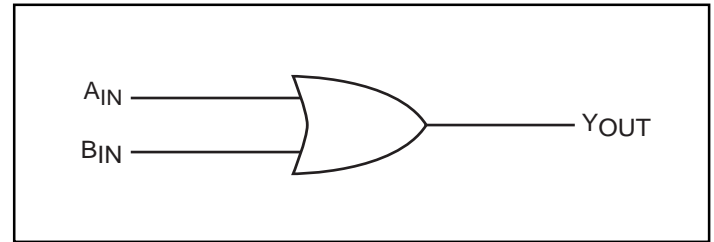

Pin Description

Pin Names	Description
A _{IN}	Input
B _{IN}	Input
Y _{OUT}	Output

Recommended Operating Conditions⁽¹⁾

Parameter	Condition	Min.	Max.	Units
Supply Voltage (V_{CC})		1.8	3.6	V
Input Voltage (V_{IN})		0	5.5	
Output Voltage (V_{OUT})		0	V_{CC}	
Operating Temperature		-40	85	°C
Input Rise and Fall Time (t_r, t_f)	$V_{CC} = 1.8\text{V}, 2.5\text{V} \pm 0.2\text{V}$	0	20	ns/V
	$V_{CC} = 3.3\text{V}, \pm 0.3\text{V}$	0	10	

Function Table

Inputs		Output
A _{IN}	B _{IN}	Y _{OUT}
L	L	L
L	H	H
H	L	H
H	H	H

Notes:

H = HIGH Logic Level
L = LOW Logic Level

Note:

1. Unused inputs must be held HIGH or LOW. They may not float.

Absolute Maximum Ratings

Supply Voltage (V _{CC})	-0.5V to +4V
DC Input Voltage (V _{IN})	-0.5V to +6V
DC Output Voltage (V _{OUT})	-0.5V to +6V
DC Input Diode Current (I _{IK})	-50mA to 20mA
DC Output Diode Current (I _{OK})	-50mA to 20mA
DC Output Current (I _{OUT})	±50mA
DC V _{CC} /GND Current (I _{CC} /I _{GND})	±50mA
Storage Temperature (T _{STG})	-65°C to +150°C
Junction Lead Temperature (I _{OS})	200°C
Power Dissipation SOT23	200mW
SC70	150mW

Note:

Absolute maximum ratings are DC values beyond which the device may be damaged or have its useful life impaired. The datasheet specifications should be met, without exception, to ensure that the system design is reliable over its power supply, temperature, and output/input loading variables. Pericom does not recommend operation outside datasheet specifications.

DC Electrical Characteristics (Over supply voltage and operating temperature ranges, unless otherwise specified)

Symbol	Parameter	V _{CC} (V)	Conditions		T _A = +25°C			T _A = -40°C to +85°C		Units
					Min.	Typ.	Max.	Min.	Max.	
V _{IH}	HIGH Level Input Voltage	1.8 2.3-3.6			0.75V _{CC} 0.70V _{CC}			0.75V _{CC} 0.70V _{CC}		V
V _{IL}	LOW Level Input Voltage	1.8 2.3-3.6					0.25V _{CC} 0.30V _{CC}	0.25V _{CC} 0.30V _{CC}		
V _{OH}	HIGH Level Output Voltage	1.8	V _{IN} = V _{IH}	I _{OH} = -100μA	1.7	1.79		1.7		
		2.3			2.2	2.29		2.2		
		3.0			2.9	2.99		2.9		
V _{OL}	LOW Level Output Voltage	2.3	V _{IN} = V _{IL}	I _{OL} = 100μA		0.01	0.1		0.1	
		3.0			0.01	0.1		0.1		
		3.0			0.00	0.1		0.1		
V _{OL}	LOW Level Output Voltage	2.3	V _{IN} = V _{IL}	I _{OL} = 8mA		0.10	0.3		0.3	
		3.0			0.18	0.4		0.4		
		3.0			0.28	0.55		0.55		
I _{IN}	Input Leakage Current	0-3.6	V _{IN} = 5.5V, GND		-1		1	-1	1	μA
I _{OFF}	Power Off Leakage Current	0.0	V _{IN} or V _{OUT} = 5.5V		-1		1	-1	1	
I _{CC}	Quiescent Supply Current	1.8-3.6	V _{IN} = 5.5V, GND				2.0		20	

AC Electrical Characteristics

Symbol	Parameter	V _{CC} (V)	Conditions	T _A = +25°C			T _A = -40°C to +85°C		Units	Fig. No.
				Min.	Typ.	Max.	Min.	Max.		
t _{PLH} , t _{PHL}	Propagation Delay	1.8 2.5 ±0.2 3.3 ±0.3	C _L = 15pF, R _L = 1MΩ	2.0 0.8 0.5	3.0 1.8 1.2	3.9 2.5 1.8	2.0 0.8 0.5	4.5 2.7 2.0	ns	1 3
t _{PLH} , t _{PHL}	Propagation Delay	3.3 ±0.3	C _L = 50pF, R _L = 500Ω	1.5	2.8	3.8	1.5	4.1		1 3
C _{IN}	Input Capacitance	V _{IN} = 0			4				pF	
C _{PD}	Power Dissipation Capacitance	3.3	Note 3		20					2

Notes:

3. C_{PD} is defined as the value of the internal equivalent capacitance which is derived from dynamic operating current consumption (I_{CCD}) at no output loading and operating at 50% duty cycle (see Figure 2). C_{PD} is related to I_{CCD} dynamic operating current by the expression: I_{CCD} = (C_{PD})(V_{CC})(f_{IN}) + (I_{CC static}).

AC Loading and Waveforms

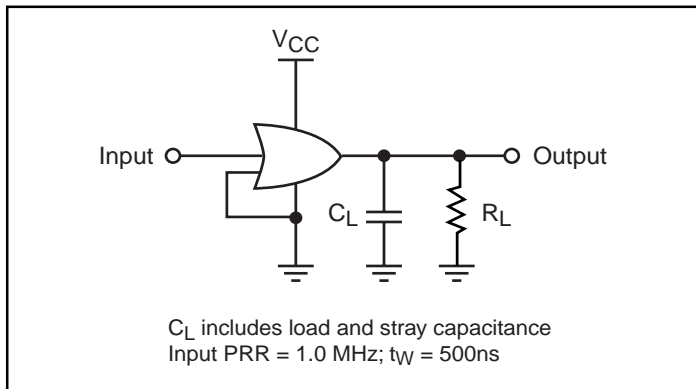

Figure 1. AC Test Circuit

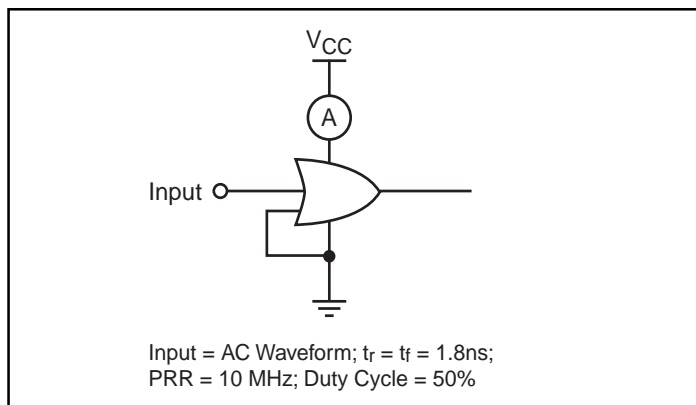

Figure 2. I_{CCD} Test Circuit

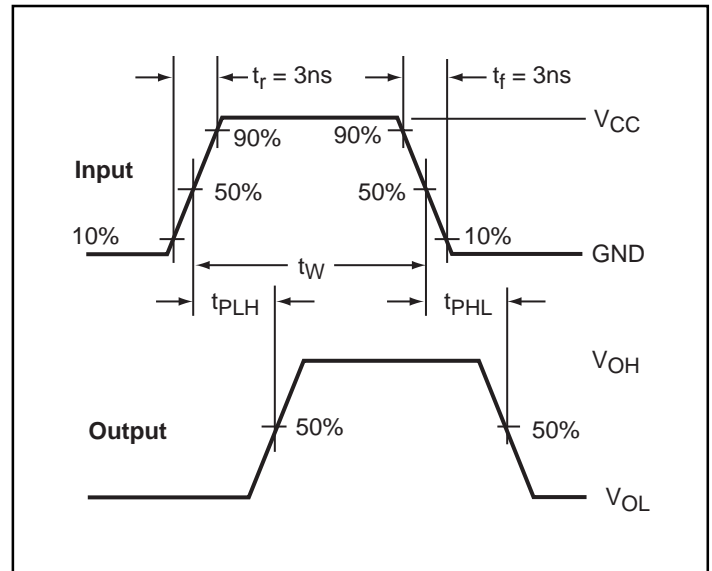
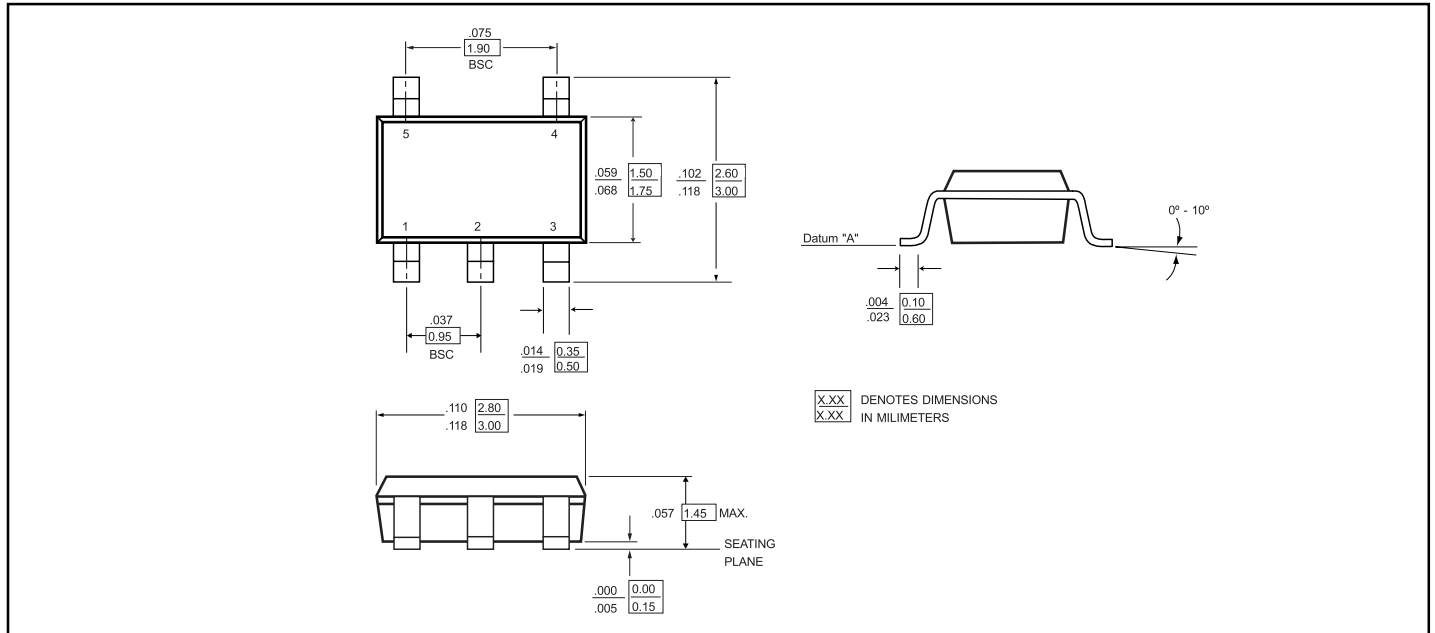
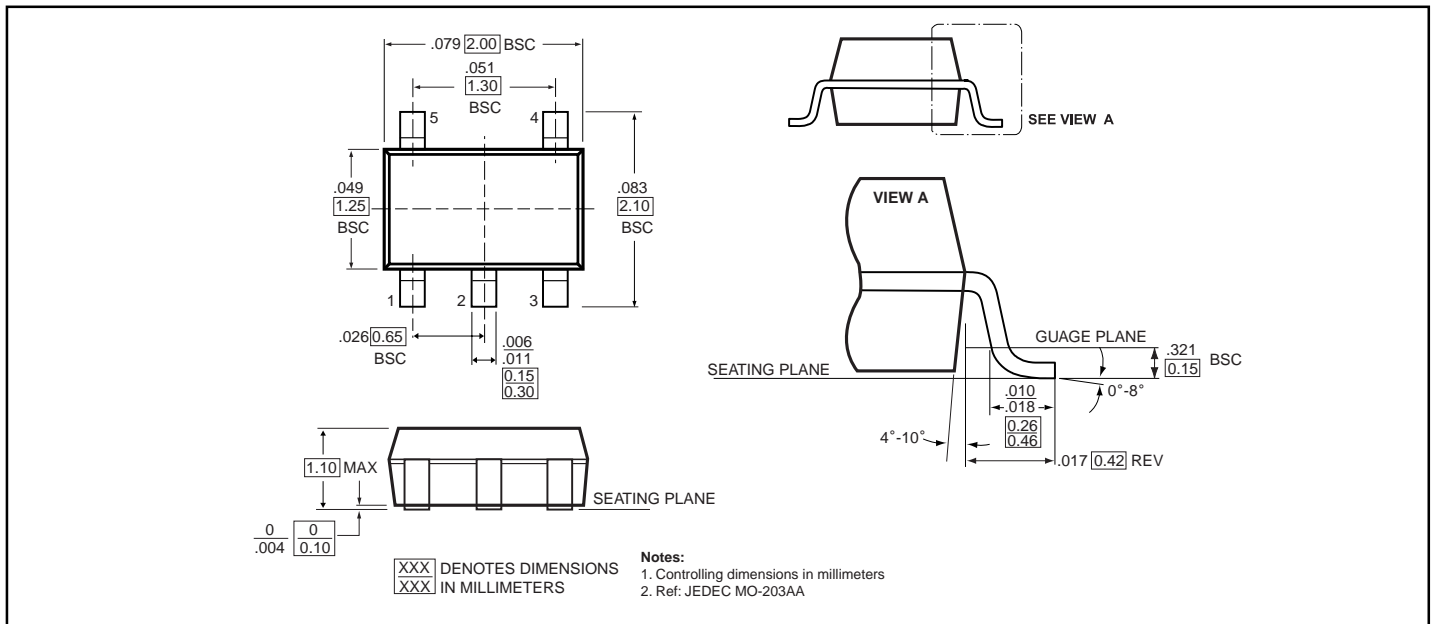

Figure 3. AC Waveforms

5-Pin SOT23 (T) Package



5-Pin SC70 (C) Package



Ordering Information

Part	Pin-Package	Top Marking	Operating Range
PI74ST1G32TX	5-Pin - SOT23	L20	-40°C to 85°C
PI74ST1G32CX	5-Pin - SC70	L20	-40°C to 85°C