

# Low Voltage Audio Power Amplifier

The PJ386 is a power amplifier designed for use in low voltage consumer applications. The gain is internally set to 20 to keep external part count low, but the addition of an external resistor and capacitor between pins 1 and 8 will increase the gain to any value up to 200.

The inputs are ground referenced while the output is automatically biased to one half the supply voltage. The quiescent power drain is only 24 milliwatts when operating from a 6 volt supply, making the PJ386 ideal for battery operation.

### FEATURES

- Battery operation
- Minimum external parts
- Wide supply voltage range 4-12 Volt
- Low quiescent current drain 4mA
- Voltage gains from 20 to 200
- Ground referenced input
- self-centering output quiescent voltage
- Low distortion
- Eight pin dual-in-line package

### APPLICATIONS

- AM-FM radio amplifiers
- Portable tape player amplifiers
- Intercoms
- TV sound systems
- Line drivers
- Ultrasonic drivers
- Small servo drivers
- Power converters

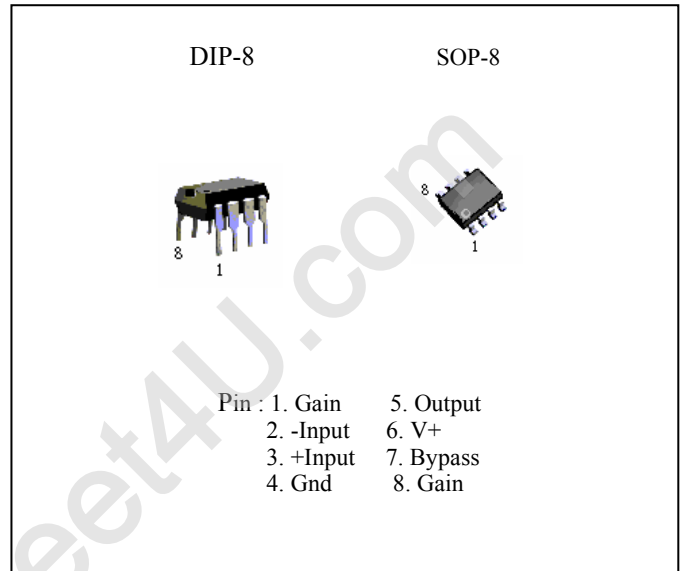

### ORDERING INFORMATION

Device	Operating Temperature	Package
PJ386CD	-20°C TO +85°C	DIP-8
PJ386CS		SOP-8

### EQUIVALENT CIRCUIT

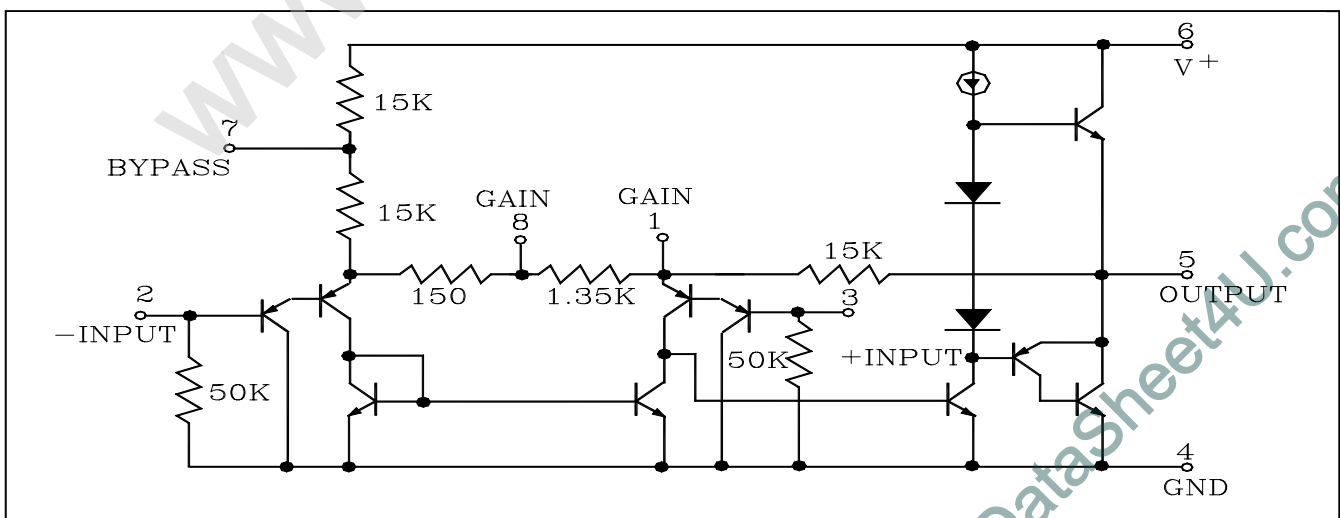

Low Voltage Audio Power Amplifier

**ABSOLUTE MAXIMUM RATINGS** (TA=25°C)

Characteristic	Symbol	Value	Unit
Supply Voltage	V+	15	V
Power Dissipation DIP-8	P <sub>D</sub>	700	mW
SOP-8		300	
Input Voltage Range	V <sub>in</sub>	0.4	V
Operating Temperature Range	T <sub>opr</sub>	-20 ~ +85	°C
Storage Temperature Range	T <sub>stg</sub>	-40 ~ +125	°C

**ELECTRICAL CHARACTERISTICS** (TA=25°C)

Parameter	Conditions	Min.	Typ.	Max.	Units
Quiescent Circuit Current(I <sub>Q</sub> )	V <sub>IN</sub> =0		4	8	mA
Output Power (P <sub>OUT</sub> )	V <sub>S</sub> =6V, R <sub>L</sub> =8Ω, THD=10%	250	325		mW
	V <sub>S</sub> =9V, R <sub>L</sub> =8Ω, THD=10%	500	700		mW
Voltage Gain (Av)	V <sub>S</sub> =6V, f=1KHz		26		dB
D-Type	10 μ F from Pin 1 to 8		46		dB
Bandwidth (BW) D-Type	V <sub>S</sub> =6V, Pins 1 and 8 Open		300		KHz
	10 μ F from Pin 1 to 8		60		
Total Harmonic Distortion(THD) (D-Type)	V <sub>S</sub> =6V, R <sub>L</sub> =8Ω, P <sub>OUT</sub> =125mW f=1KHz, Pins 1 and 8 open		0.2		%
Power Supply Rejection Ratio (PSRR)	V <sub>S</sub> =6V, f=1KHz, C <sub>BY PASS</sub> =10 μ F Pins 1 and 8 Open, Referred to Output		50		dB
Input Resistance (R <sub>IN</sub> )			50		KΩ
Input Bias Current (I <sub>BIAS</sub> )	V <sub>S</sub> =6V, Pins 2 and 3 Open		250		nA

(note 1) Set the maximum junction temperature to 125°C and reduce the thermal resistance to 143°C/W when the ambient temperature is high.

(note 2) Insert a 10 Ω resistor and 0.05 μ F capacitor in series to ground terminal from pin 5.

**TYPICAL APPLICATION**

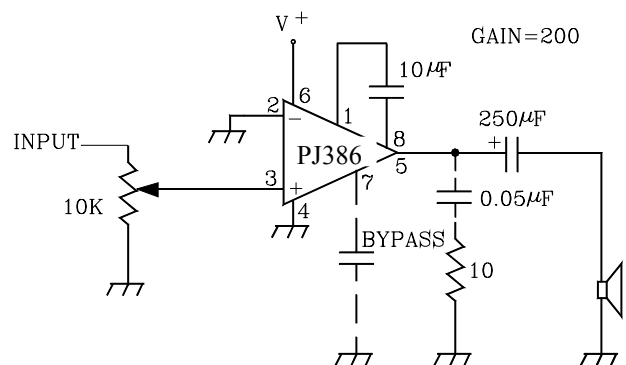
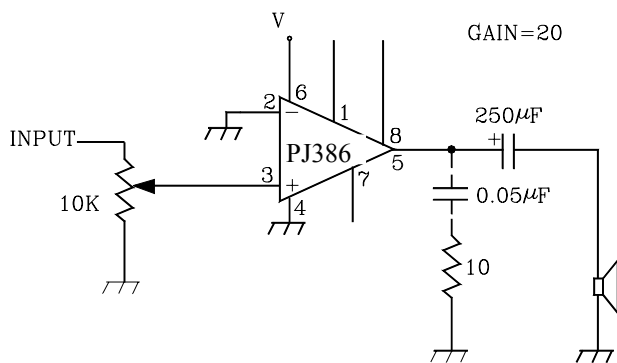

Low Voltage Audio Power Amplifier

TYPICAL CHARACTERISTICS (Ta=25°C)

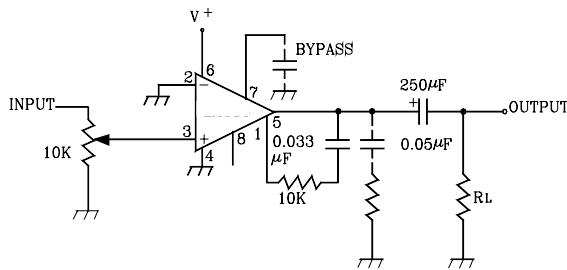

Amplifier 2

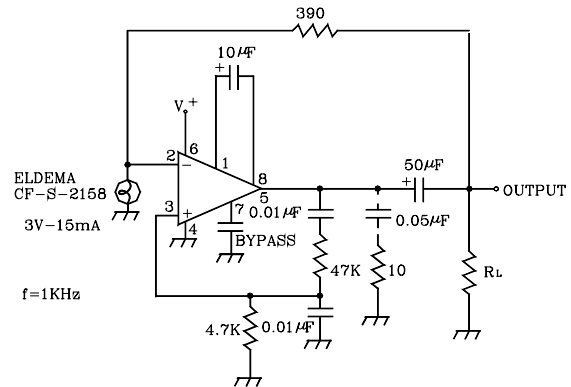

Square Wave Oscillator

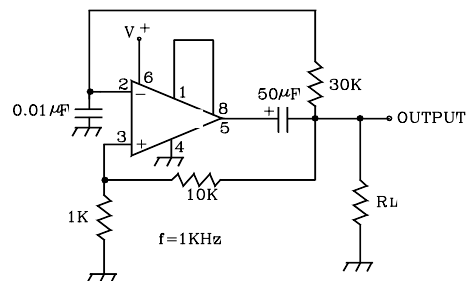
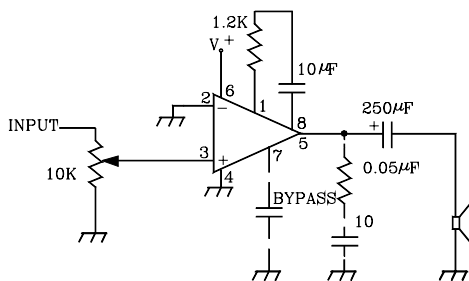

APPLICATION HINTS

GAIN CONTROL

To make the PJ386 a more versatile amplifier, two pins ( 1 and 8 ) are provided for gain control. With pins 1 to 8 open the 1.35KΩ resistor sets the gain at 20 (26dB). If a capacitor is put from pin 1 to 8, bypassing the 1.35 KΩ resistor, the gain will go up to 200 (46 dB). If a resistor is placed in series with the capacitor, the gain can be set to any value from 20 to 200. Gain control can also be done by capacitively coupling a resistor (or FET ) from pin 1 to ground.

Additional external components can be placed in parallel with the internal feedback resistors to tailor the gain and frequency response for individual applications. For example, we can compensate poor speaker bass response by frequency shaping the feedback path. This is done with a series RC from pin 1 to 5 (paralleling the internal 15 KΩ resistor). For 6 dB effective bass boost:  $R \approx 15 K\Omega$ , the lowest values for good stable operation is  $R_{min} = 10 K\Omega$  if pin 8 is open. If pins 1 and 8 are bypassed then R as low 2 KΩ can be used. This restriction is because the amplifier is only compensated for closed-loop gains greater than 9.

INPUT BIASING

The schematic shows that both inputs are biased to ground with a 50 K resistor. The base current of the input transistors is about 250nA , so the inputs are at about 12.5mV when left open. If the dc source resistance driving the PJ386 is higher than 250 KΩ it will contribute very little additional offset (about 2.5mV at the input, 50mV at the output ). If the dc source resistance is less than 10 KΩ , then shorting the unused input to ground will keep the offset low (about 2.5mV at the input , 50mV at the output). For dc source resistances between these values we can eliminate excess offset by putting a resistor from the unused input to ground, equal in value to the dc source resistance. Of course all offset problems are eliminated if the input is capacitively coupled.

When using the PJ386 with higher gains (bypassing the 1.35 KΩ resistor between pins 1 and 8) it is necessary to bypass the unused input , preventing degradation of gain and possible instabilities. This is done with a 0.1 µ F capacitor or a short to ground depending on the dc source resistance on the driven input.

# Low Voltage Audio Power Amplifier

**Quiescent Current vs. Supply Voltage**

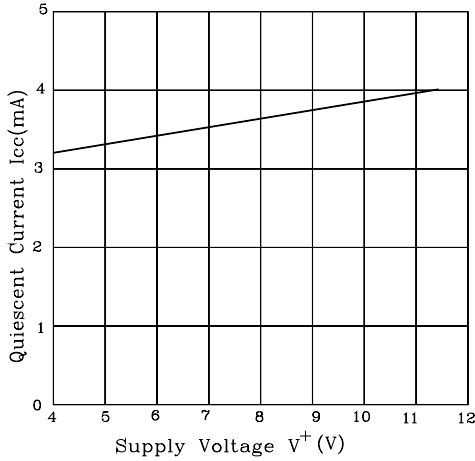

**Maximum Output Voltage Swing vs. Supply Voltage**

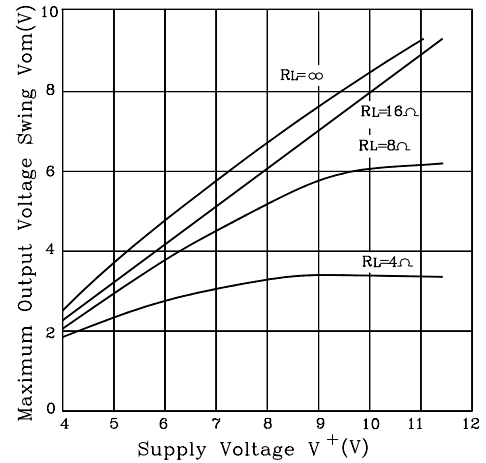

**Voltage Gain vs. Frequency**

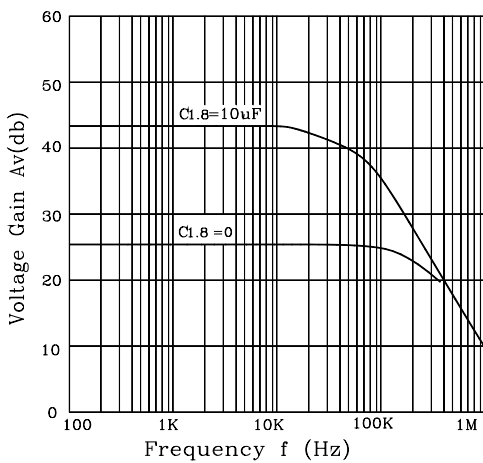

**Power Supply Rejection Ratio vs. Frequency**  
( $V^+ = 6V, A_v = 26dB$ )

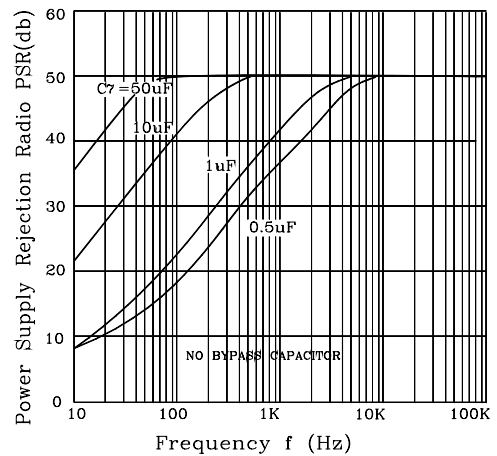

**Total Harmonic Distortion vs. Frequency**  
( $V^+ = 6V, R_L = 8\Omega, P_o = 125mW, A_v = 26dB$ )

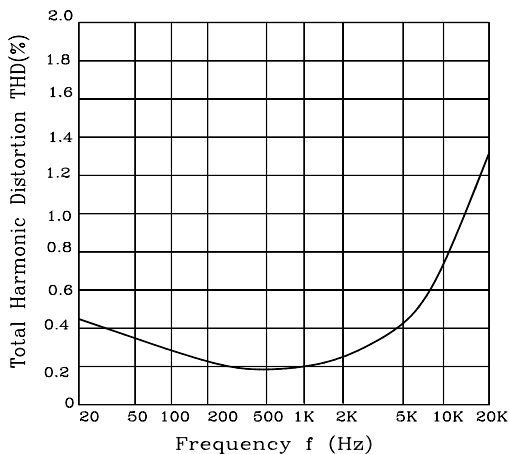

**Total Harmonic Distortion vs. Output Power**  
( $V^+ = 6V, R_L = 8\Omega, f = 1KHz$ )

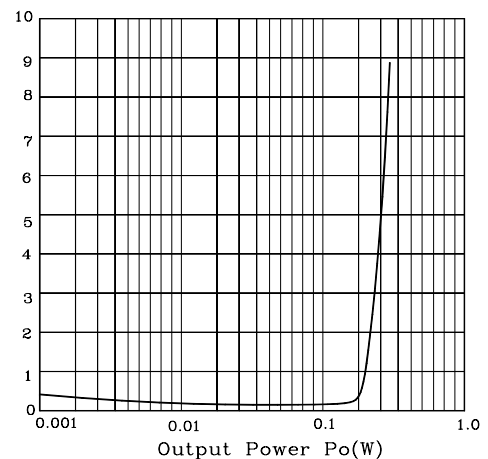

Low Voltage Audio Power Amplifier

Power Dissipation vs. Output Power( $R_L=4\ \Omega$ )

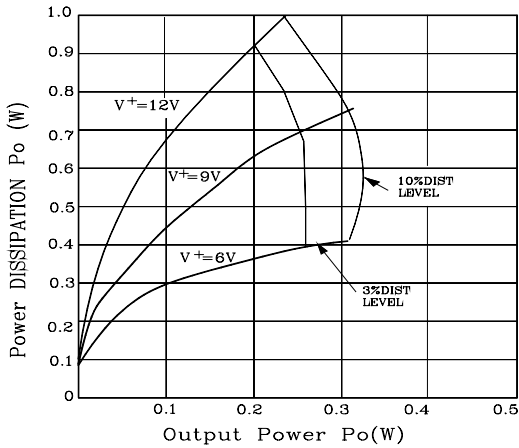

Power Dissipation vs. Output Power( $R_L=8\ \Omega$ )

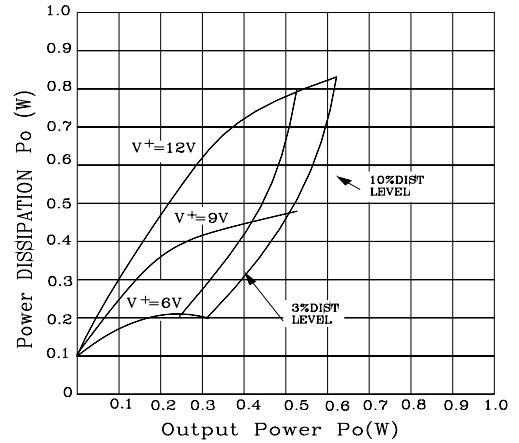

Power Dissipation vs. Output Power( $R_L=16\ \Omega$ )

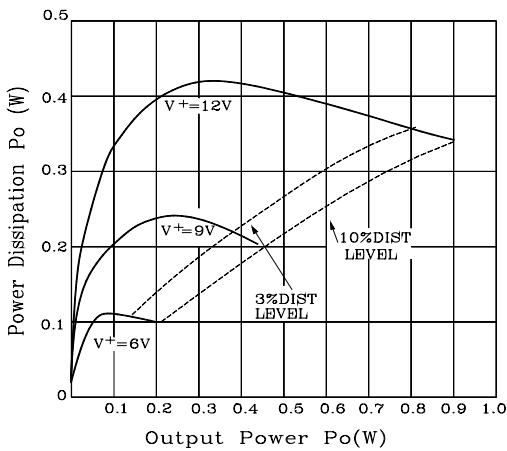

Frequency Response with Base Boost

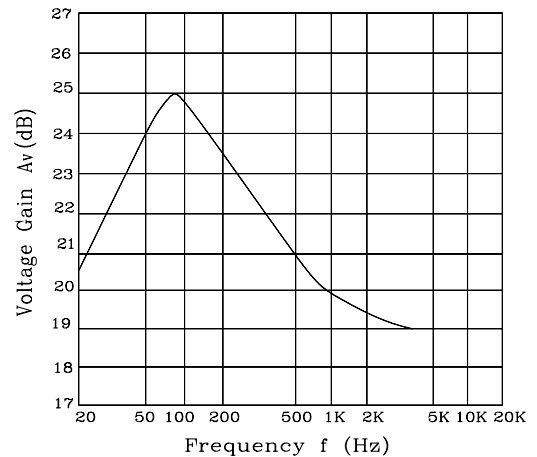

Power Dissipation vs. Ambient Temperature

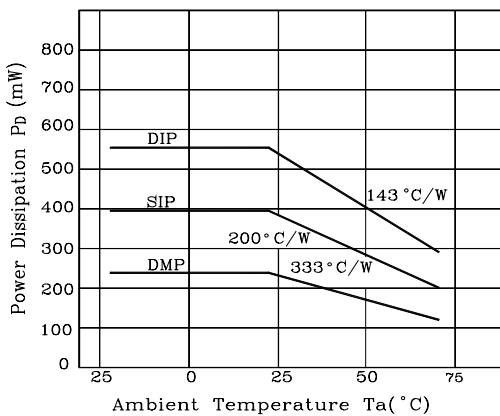

Low Voltage Audio Power Amplifier

DIP-8

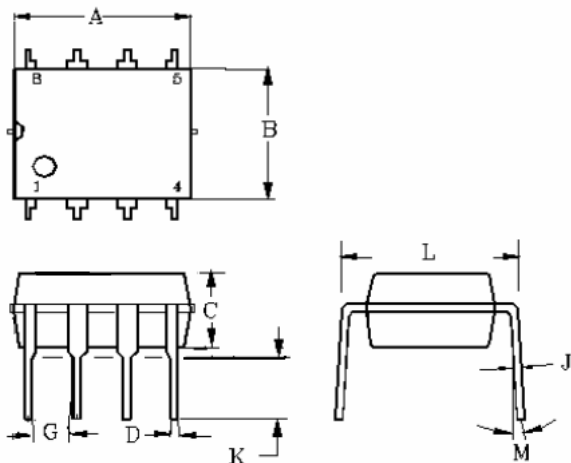

DIM	MILLIMETERS		INCHES	
	MIN	MAX	MIN	MAX
A	9.07	9.32	0.357	0.367
B	6.22	6.48	0.245	0.255
C	3.18	4.43	0.125	0.135
D	0.35	0.55	0.019	0.020
G	2.54BSC		0.10BSC	
J	0.29	0.31	0.011	0.012
K	3.25	3.35	0.128	0.132
L	7.75	8.00	0.305	0.315
M	-	10°	-	10°

SOP-8

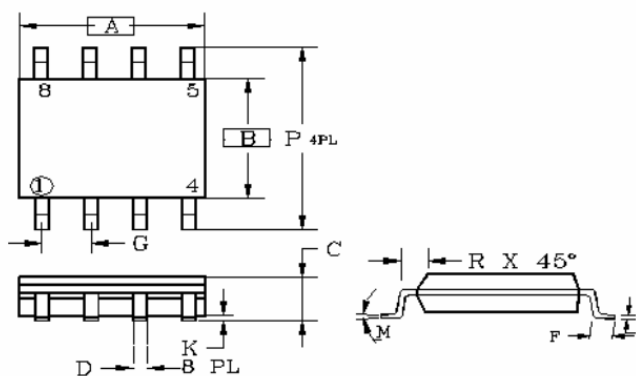

DIM	MILLIMETERS		INCHES	
	MIN	MAX	MIN	MAX
A	4.80	5.00	0.189	0.196
B	3.80	4.00	0.150	0.157
C	1.35	1.75	0.054	0.068
D	0.35	0.49	0.014	0.019
F	0.40	1.25	0.016	0.049
G	1.27BSC		0.05BSC	
K	0.10	0.25	0.004	0.009
M	0°	7°	0°	7°
P	5.80	6.20	0.229	0.244
R	0.25	0.50	0.010	0.019