

**3-Terminal Low Current Positive Voltage Regulators**

The PJ78L00 Series of positive voltage Regulators are inexpensive, easy-to-use devices suitable for a multitude of applications that require a regulated supply of up to 100 mA. Like their higher powered PJ7800 Series cousins, these regulators feature internal current limiting and thermal shutdown making them remarkably rugged. No external components are required with the PJ78L00 devices in many applications.

These devices offer a substantial performance advantage over the traditional zener diode-resistor combination, as output impedance and quiescent current are substantially reduced.

**FEATURES**

- Wide Range of Available, Fixed Output Voltages
- Low Cost
- Internal Short Circuit Current Limiting
- Internal Thermal Overload Protection
- No External Components Required
- Complementary Negative Regulators Offered (PJ79L00 Series)
- Available in ±4% Voltage Tolerance.

**CIRCUIT SCHEMATIC**

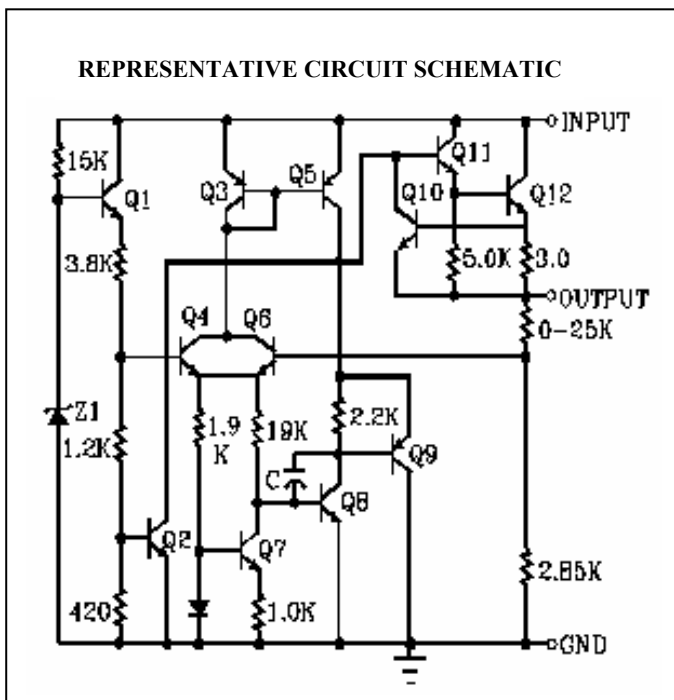

TO-92

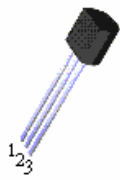

Pin 1. Output  
2. Ground  
3. Input

SOT-89



PJ78L00  
Pin 1. Input  
2. Ground  
3. Output

PJ78L00A  
1. Output  
2. Ground  
3. Input

(Heatsink surface connected to Pin 2)

SOP-8

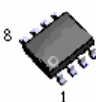

Pin: 1.Vout 5.Nc  
2.Gnd 6.Gnd  
3.Gnd 7.Gnd  
4.Nc 8.Vin

**ORDERING INFORMATION**

Device	Operating Temperature	Package
PJ78LxxCT	-20°C to +85°C	TO-92
PJ78LxxCS		SOP-8
PJ78LxxCY		SOT-89
PJ78LxxACY		

**TYPICAL CONNECTING CIRCUIT**

**STANDARD APPLICATION**

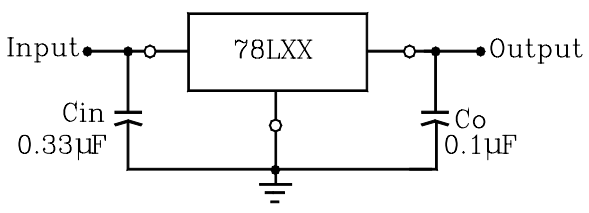

A common ground is required between the input and the output voltages. The input voltage must remain typical 2.0V above the output voltage even during the low point on the input ripple voltage.

\*=Cin is required if regulator is located an appreciable distance from from power supply filter.

\*\*=Co is not needed for stability, however, it does improve transient response.

### 3-Terminal Low Current Positive Voltage Regulators

**MAXIMUM RATINGS** (Ta=+25°C unless otherwise noted.)

RATING	SYMBOL	PJ78L00 SERIES	UNIT
Input Voltage	Vi *1	35	V
Input Voltage	Vi *2	40	V
Storage Junction Temperature Range	Tstg	-65 to +150	°C
Operating Junction Temperature Range	Tj	0 to +150	°C

Note : \*1. PJ78L05 to PJ78L18

\*2. PJ78L24

- This specification applies only for DC power dissipation permitted by absolute maximum ratings.
- Pulse testing techniques are used to maintain the junction temperature as close to the ambient temperature as possible. Thermal effects must be taken into account separately. All characteristics are measured with a 0.33uF capacitor across the input and a 0.1uF capacitor across the output.

**PJ78L05 ELECTRICAL CHARACTERISTICS**

(Vi=10V, Io=40mA, Ci=0.33µF, Co=0.1µF, 0°C < Tj < +125°C unless otherwise noted.)

CHARACTERISTIC	SYMBOL	MIN	TYP	MAX	UNIT
Output Voltage (Tj=+25°C)	Vo	4.8	5.0	5.2	Vdc
Line Regulation (Tj=+25°C, Io=40mA) 7.0V ≤ Vi ≤ 20V	REGline	--	55	150	mV
8.0V ≤ Vi ≤ 20V		--	45	100	
Load Regulation Tj=+25°C, 1.0mA ≤ Io ≤ 100mA	REGload	--	11	60	mV
Tj=+25°C, 1.0mA ≤ Io ≤ 40mA		--	5.0	30	
Output Voltage 7.0V ≤ Vi ≤ 20V, 1.0mA ≤ Io ≤ 40mA	Vo	4.75	--	5.25	Vdc
Vi = 10V, 1.0mA ≤ Io ≤ 70mA		4.75	--	5.25	
Input Bias Current (Tj=+25°C)	I <sub>IB</sub>	--	3.8	6.0	mA
(Tj=+125°C)		--	--	5.5	
Input Bias Current Change 8.0V ≤ Vi ≤ 20V	Δ I <sub>IB</sub>	--	--	1.5	mA
1.0mA ≤ Io ≤ 40mA		--	--	0.1	
Output Noise Voltage (Ta=+25°C, 10Hz ≤ f ≤ 100KHz)	Vn	--	40	--	µV
Ripple Rejection (Io=40mA, f=120Hz, 8.0V ≤ Vi ≤ 18V, Tj=+25°C)	RR	41	49	--	dB
Dropout Voltage	Vi-Vo		1.7		Vdc

3-Terminal Low Current Positive Voltage Regulators

**• PJ78L08 ELECTRICAL CHARACTERISTICS**

( $V_i=14V, I_o=40mA, C_i=0.33\mu F, C_o=0.1\mu F, 0^\circ C < T_j < +125^\circ C$ , unless otherwise noted.)

CHARACTERISTIC	SYMBOL	MIN	TYP	MAX	UNIT
Output Voltage ( $T_j = +25^\circ C$ )	$V_o$	7.7	8.0	8.3	Vdc
Line Regulation( $T_j = +25^\circ C, I_o=40mA$ ) $10.5V \leq V_i \leq 23V$ , $11V \leq V_i \leq 23V$ ,	REGline	--	20	175	mV
Load Regulation $T_j = +25^\circ C, 1.0mA \leq I_o \leq 100mA$ $T_j = +25^\circ C, 1.0mA \leq I_o \leq 40mA$	REGload	--	15	80	mV
Output Voltage $10.5V \leq V_i \leq 23V, 1.0mA \leq I_o \leq 40mA$ $V_i = 14V, 1.0mA \leq I_o \leq 70mA$	$V_o$	7.6	--	8.4	Vdc
Input Bias Current ( $T_j = +25^\circ C$ ) ( $T_j = +125^\circ C$ )	$I_{IB}$	--	3.0	6.0	mA
Input Bias Current Change $11V \leq V_i \leq 23V$ $1.0mA \leq I_o \leq 40mA$	$\Delta I_{IB}$	--	--	1.5	mA
Output Noise Voltage ( $T_a = +25^\circ C, 10Hz \leq f \leq 100KHz$ )	$V_n$	--	60	--	$\mu V$
Ripple Rejection ( $I_o=40mA, f=120Hz, 12V \leq V_i \leq 23V, T_j = +25^\circ C$ )	RR	37	57	--	dB
Dropout Voltage ( $T_j = +25^\circ C$ )	$V_i - V_o$	--	1.7	--	Vdc

**• PJ78L09 ELECTRICAL CHARACTERISTICS**

( $V_i=15V, I_o=40mA, C_i=0.33 \mu F, C_o=0.1 \mu F, -40^\circ C < T_j < +125^\circ C$  (for PJ78LXX),  $0^\circ C < T_j < 125^\circ C$  (PJ78LXX), unless otherwise noted.)

CHARACTERISTIC	SYMBOL	MIN	TYP	MAX	UNIT
Output Voltage ( $T_j = +25^\circ C$ )	$V_o$	8.6	9.0	9.4	Vdc
Line Regulation( $T_j = +25^\circ C, I_o=40mA$ ) $11.5V \leq V_i \leq 24V$ , $12V \leq V_i \leq 24V$ ,	REGline	--	20	175	mV
Load Regulation $T_j = +25^\circ C, 1.0mA \leq I_o \leq 100mA$ $T_j = +25^\circ C, 1.0mA \leq I_o \leq 40mA$	REGload	--	15	90	mV
Output Voltage $11.5V \leq V_i \leq 24V, 1.0mA \leq I_o \leq 40mA$ $V_i = 15V, 1.0mA \leq I_o \leq 70mA$	$V_o$	8.5	--	9.5	Vdc
Input Bias Current ( $T_j = +25^\circ C$ ) ( $T_j = +125^\circ C$ )	$I_{IB}$	--	3.0	6.0	mA
Input Bias Current Change $11V \leq V_i \leq 23V$ $1.0mA \leq I_o \leq 40mA$	$\Delta I_{IB}$	--	--	1.5	mA
Output Noise Voltage ( $T_a = +25^\circ C, 10Hz \leq f \leq 100KHz$ )	$V_n$	--	60	--	$\mu V$
Ripple Rejection ( $I_o=40mA, f=120Hz, 12V \leq V_i \leq 23V, T_j = +25^\circ C$ )	RR	37	57	--	dB
Dropout Voltage ( $T_j = +25^\circ C$ )	$V_i - V_o$	--	1.7	--	Vdc

3-Terminal Low Current Positive Voltage Regulators

**• PJ78L12 ELECTRICAL CHARACTERISTICS**

( $V_I = 19V, I_o = 40mA, C_1 = 0.33\mu F, C_o = 0.1\mu F, 0^\circ C < T_J < +125^\circ C$  unless otherwise noted.)

CHARACTERISTIC	SYMBOL	MIN	TYP	MAX	UNIT
Output Voltage ( $T_J = +25^\circ C$ )	$V_o$	11.5	12	12.5	Vdc
Line Regulation ( $T_J = +25^\circ C, I_o = 40mA$ ) 14.5V $\leq V_I \leq 27V$ 16V $\leq T_J \leq 27V$	REGline	--	120 100	250 200	mV
Load Regulation $T_J = +25^\circ C, 1.0mA \leq I_o \leq 100mA$ $T_J = +25^\circ C, 1.0mA \leq I_o \leq 40mA$	REGload		20 10	100 50	mV
Output Voltage 14.5V $\leq V_I \leq 27V, 1.0mA \leq I_o \leq 40mA$ $V_I = 19V, 1.0mA \leq I_o \leq 70mA$	$V_o$	11.4 11.4	-- --	12.6 12.6	Vdc
Input Bias Current ( $T_J = +25^\circ C$ ) ( $T_J = +125^\circ C$ )	$I_{IB}$	-- --	42 --	6.5 6.0	mA
Input Bias Current Change 16V $\leq V_I \leq 27V$ 1.0mA $\leq I_o \leq 40mA$	$\Delta I_{IB}$	-- --	-- --	1.5 0.1	mA
Output Noise Voltage ( $T_a = +25^\circ C, 10Hz \leq f \leq 100KHz$ )	$V_n$	--	80	--	$\mu V$
Ripple Rejection ( $I_o = 40mA, f = 120Hz, 15V \leq V_I \leq 25V, T_J = +25^\circ C$ )	RR	36	42	--	dB
Dropout Voltage ( $T_J = +25^\circ C$ )	$V_i - V_o$	--	1.7	--	Vdc

**• PJ78L15 ELECTRICAL CHARACTERISTICS**

( $V_I = 23V, I_o = 40mA, C_1 = 0.33\mu F, C_o = 0.1\mu F, 0^\circ C < T_J < +125^\circ C$  unless otherwise noted.)

CHARACTERISTIC	SYMBOL	MIN	TYP	MAX	UNIT
Output Voltage ( $T_J = +25^\circ C$ )	$V_o$	14.4	15	15.6	Vdc
Line Regulation ( $T_J = +25^\circ C, I_o = 40mA$ ) 17.5V $\leq V_I \leq 30V$ 20V $\leq V_I \leq 30V$	REGline	--	130 110	300 250	mV
Load Regulation $T_J = +25^\circ C, 1.0mA \leq I_o \leq 100mA$ $T_J = +25^\circ C, 1.0mA \leq I_o \leq 40mA$	REGload	--	25 12	150 75	mV
Output Voltage 17.5V $< V_I < 30V, 1.0mA \leq I_o \leq 40mA$ $V_I = 23V, 1.0mA \leq I_o \leq 70mA$	$V_o$	14.25 14.25	-- --	15.75 15.75	Vdc
Input Bias Current ( $T_J = +25^\circ C$ ) ( $T_J = +125^\circ C$ )	$I_{IB}$	-- --	4.4 --	6.5 6.0	mA
Input Bias Current Change 20V $\leq V_I \leq 30V$ 1.0mA $\leq I_o \leq 40mA$	$\Delta I_{IB}$	-- --	-- --	1.5 0.1	mA
Output Noise Voltage ( $T_a = +25^\circ C, 10Hz \leq f \leq 100KHz$ )	$V_n$	--	90	--	$\mu V$
Ripple Rejection ( $I_o = 40mA, f = 120Hz, 18.5V \leq V_I \leq 28.5V, T_J = +25^\circ C$ )	RR	34	39	--	dB
Dropout Voltage ( $T_J = +25^\circ C$ )	$V_i - V_o$	--	1.7	--	Vdc

3-Terminal Low Current Positive Voltage Regulators

**• PJ78L18 ELECTRICAL CHARACTERISTICS**

( $V_I = 27V$ ,  $I_o = 40mA$ ,  $C_I = 0.33\mu F$ ,  $C_o = 0.1\mu F$ ,  $0^\circ C < T_J < +125^\circ C$  unless otherwise noted.)

CHARACTERISTIC	SYMBOL	MIN	TYP	MAX	UNIT
Output Voltage ( $T_J = +25^\circ C$ )	$V_o$	17.3	18	18.7	Vdc
Line Regulation( $T_J = +25^\circ C$ , $I_o = 40mA$ ) 20.7V $\leq V_I \leq 33V$ 21V $\leq V_I \leq 33V$	REGline	--	45 35	325 275	mV
Load Regulation $T_J = +25^\circ C$ , $1.0mA \leq I_o \leq 100mA$ $T_J = +25^\circ C$ , $1.0mA \leq I_o \leq 40mA$	REGload	--	30 15	170 85	mV
Output Voltage 21.5V $\leq V_I \leq 33V$ , $1.0mA \leq I_o \leq 40mA$ $V_I = 27V$ , $1.0mA \leq I_o \leq 70mA$	$V_o$	17.1 17.1	-- --	18.9 18.9	Vdc
Input Bias Current ( $T_J = +25^\circ C$ ) ( $T_J = +125^\circ C$ )	$I_{IB}$	-- --	3.1 --	6.5 6.0	mA
Input Bias Current Change 22V $\leq V_I \leq 33V$ $1.0mA \leq I_o \leq 40mA$	$\Delta I_{IB}$	-- --	-- --	1.5 0.1	mA
Output Noise Voltage ( $T_a = +25^\circ C$ , $10Hz \leq f \leq 100KHz$ )	$V_n$	--	150	--	$\mu V$
Ripple Rejection ( $I_o = 40mA$ , $f = 120Hz$ , $23V \leq V_I \leq 33V$ , $T_J = +25^\circ C$ )	RR	31	45	--	dB
Dropout Voltage ( $T_J = +25^\circ C$ )	$V_i - V_o$	--	1.7	--	Vdc

**• PJ78L24 ELECTRICAL CHARACTERISTICS**

( $V_I = 33V$ ,  $I_o = 40mA$ ,  $C_I = 0.33\mu F$ ,  $C_o = 0.1\mu F$ ,  $0^\circ C < T_J < +125^\circ C$  unless otherwise noted.)

CHARACTERISTIC	SYMBOL	MIN	TYP	MAX	UNIT
Output Voltage ( $T_J = +25^\circ C$ )	$V_o$	23	24	24	Vdc
Line Regulation( $T_J = +25^\circ C$ , $I_o = 40mA$ ) 27.5V $\leq V_I \leq 38V$ 28V $\leq V_I \leq 80V$	REGline	--	50 60	350 300	mV
Load Regulation $T_J = +25^\circ C$ , $1.0mA \leq I_o \leq 100mA$ $T_J = +25^\circ C$ , $1.0mA \leq I_o \leq 40mA$	REGload	--	40 20	200 100	mV
Output Voltage 28V $\leq V_I \leq 38V$ , $1.0mA \leq I_o \leq 40mA$ 28V $\leq V_I \leq 33V$ , $1.0mA \leq I_o \leq 70mA$	$V_o$	22.8 22.8	-- --	25.2 25.2	Vdc
Input Bias Current ( $T_J = +25^\circ C$ ) ( $T_J = +125^\circ C$ )	$I_{IB}$	-- --	3.1 --	6.5 6.0	mA
Input Bias Current Change 28V $\leq V_I \leq 38V$ $1.0mA \leq I_o \leq 40mA$	$\Delta I_{IB}$	-- --	-- --	1.5 0.1	mA
Output Noise Voltage ( $T_a = +25^\circ C$ , $10Hz \leq f \leq 100KHz$ )	$V_n$	--	200	--	$\mu V$
Ripple Rejection ( $I_o = 40mA$ , $f = 120Hz$ , $29V \leq V_I \leq 35V$ , $T_J = +25^\circ C$ )	RR	31	45	--	dB
Dropout Voltage ( $T_J = +25^\circ C$ )	$V_i - V_o$	--	1.7	--	Vdc

3-Terminal Low Current Positive Voltage Regulators

FIGURE 1-DROPOUT CHARACTERISTICS

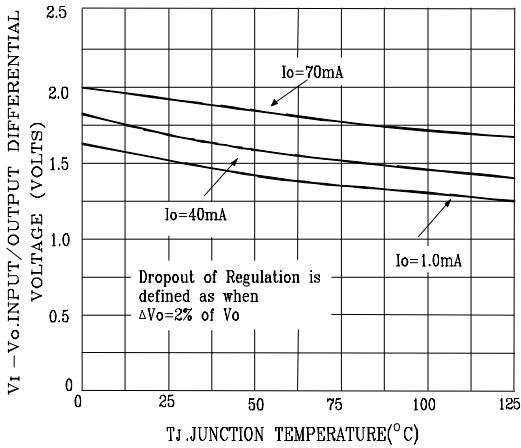

FIGURE 2 - DROPOUT VOLTAGE versus JUNCTION TEMPERATURE

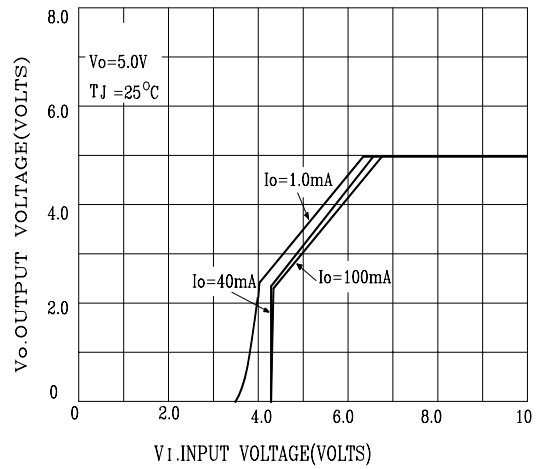

FIGURE 3 - INPUT BIAS CURRENT versus AMBIENT TEMPERATURE

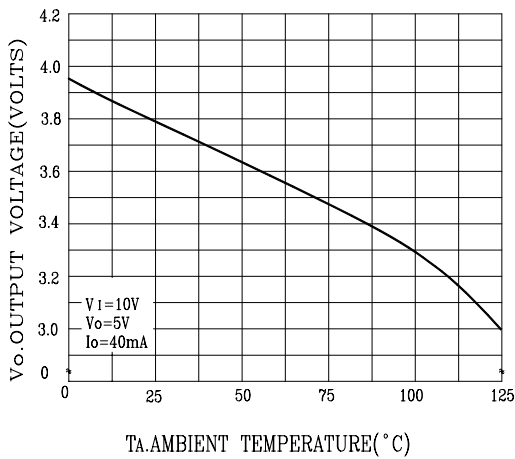

FIGURE 4 - INPUT BIAS CURRENT versus INPUT VOLTAGE

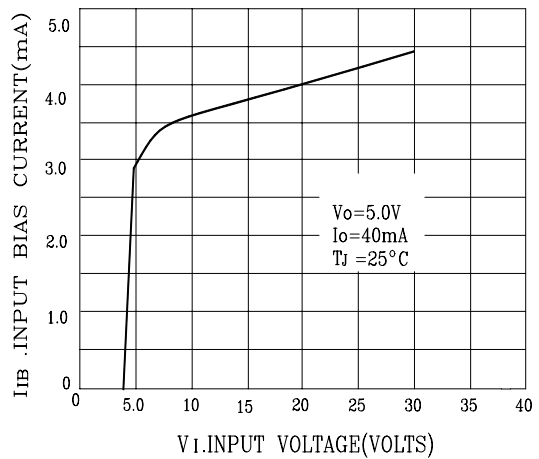
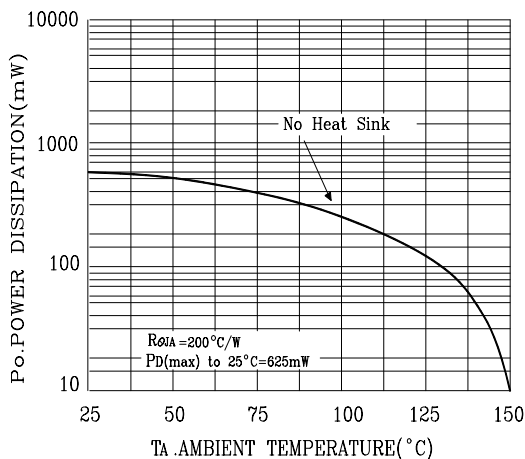
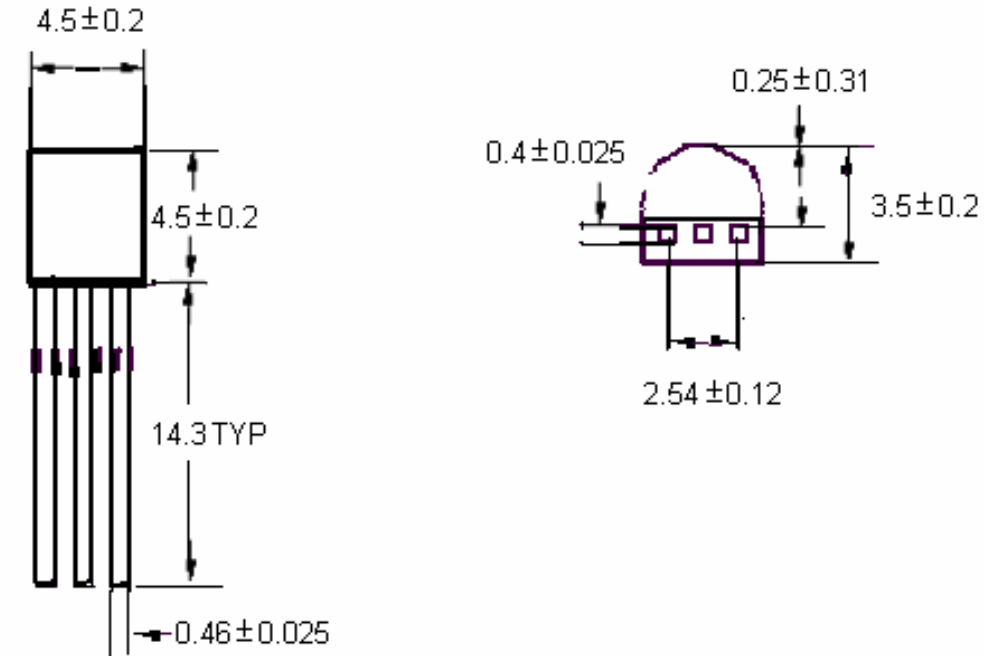

FIGURE 5 - MAXIMUM AVERAGE POWER DISSIPATION versus AMBIENT TEMPERATURE



3-Terminal Low Current Positive Voltage Regulators

TO-92 Unit:mm



SOT-89 Unit:mm

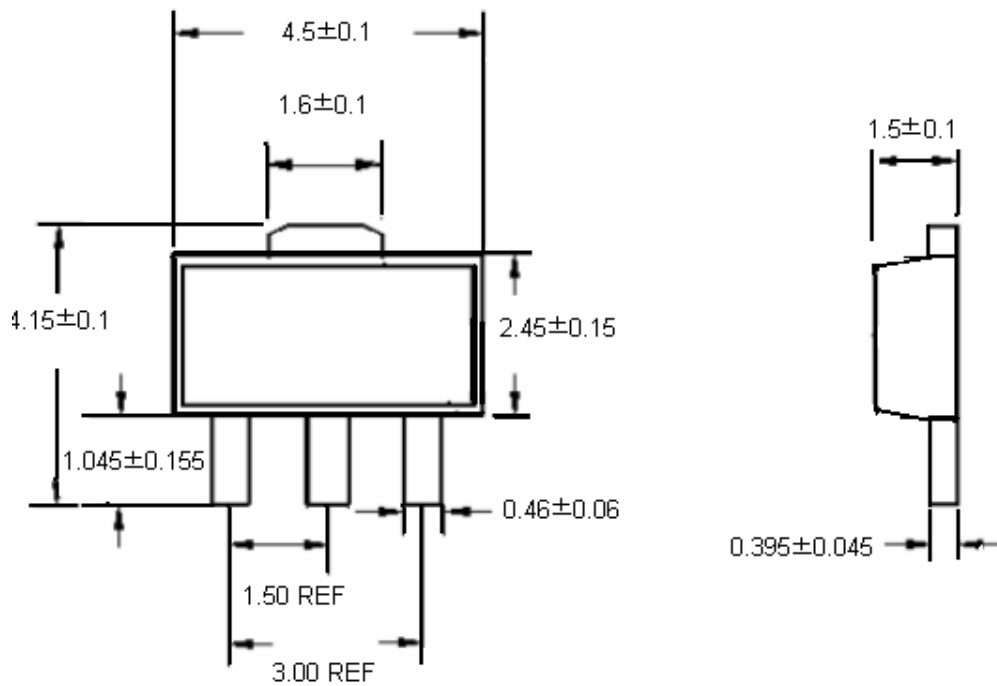

3-Terminal Low Current Positive Voltage Regulators

SOP-8

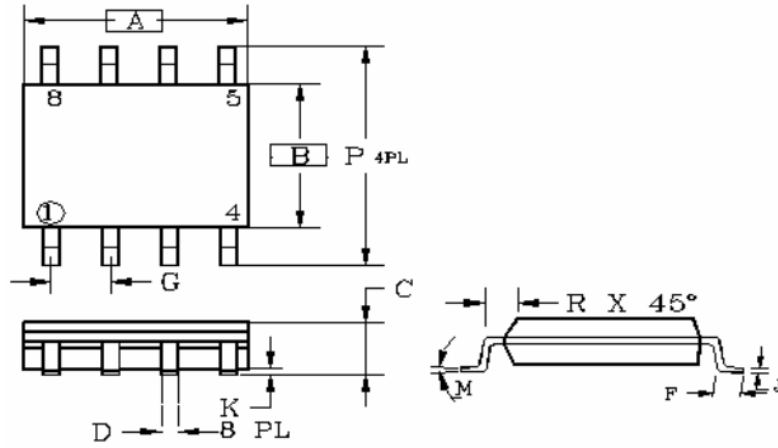

DIM	MILLIMETERS		INCHES	
	MIN	MAX	MIN	MAX
A	4.80	5.00	0.189	0.196
B	3.80	4.00	0.150	0.157
C	1.35	1.75	0.054	0.068
D	0.35	0.49	0.014	0.019
F	0.40	1.25	0.016	0.049
G	1.27BSC		0.05BSC	
K	0.10	0.25	0.004	0.009
M	0°	7°	0°	7°
P	5.80	6.20	0.229	0.244
R	0.25	0.50	0.010	0.019