

**ZENER DIODES
 DIODES ZENER**

1,3 W silicon Zener diodes, hermetically sealed plastic according to normalization CCTU : F 126 offering the following advantages :

- Large voltage range : 3,3 V to 200 V
- High surge capability : 30 W @ 10 ms

Diodes Zener de 1,3 W au silicium encapsulées plastique selon normalisation CCTU : F 126 offrant les avantages suivants :

- *Gamme de tension étendue : 3,3 V à 200 V*
- *Forte tenue en surcharge : 30 W @ 10 ms*

$$P_{tot} = 1,3 \text{ W}$$

$$3,3 \text{ V} \leq V_{ZT \text{ nom}} \leq 200 \text{ V}$$

Case : F-126 (CB-210)
 Boîtier :

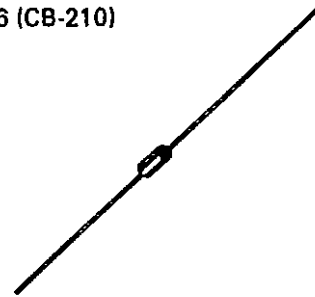

**ABSOLUTE RATINGS (LIMITING VALUES)
 VALEURS LIMITES ABSOLUES D'UTILISATION**

$T_{amb} = 50^{\circ}\text{C}$

$d = 10 \text{ mm}$

(Unless otherwise stated)
 (Sauf indications contraires)

DC power dissipation (see fig. 1) <i>Dissipation de puissance en régime permanent (voir fig. 1)</i>	P_{tot}	1,3	W
Continuous reverse current <i>Courant inverse continu</i>	I_{ZM}	See page 2 <i>Voir page 2</i>	mA
Non repetitive surge peak power dissipation ($t = 10 \text{ ms}$) (see fig. 4) <i>Puissance de surcharge crête accidentelle ($t = 10 \text{ ms}$) (voir fig. 4)</i> $T_{j \text{ initial}} = 25^{\circ}\text{C}$	P_{RSM}	30	W
Operating temperature <i>Température de fonctionnement</i>	T_{oper}	$-55 \rightarrow +150$	$^{\circ}\text{C}$
Storage temperature <i>Température de stockage</i>	T_{stg}	$-55 \rightarrow +150$	$^{\circ}\text{C}$
Maximum junction temperature <i>Température maximale de jonction</i> max	T_j	150	$^{\circ}\text{C}$
Maximum lead temperature for soldering during 3 s at 5 mm from case <i>Température maximum de soudure des connexions pendant 3 s à 5 mm du boîtier</i>	T_L	300	$^{\circ}\text{C}$

Junction-ambient thermal resistance
Résistance thermique jonction-ambiante

max

$R_{th(j-a)}$

75

$^{\circ}\text{C/W}$

December 1982 SH/3

ELECTRICAL CHARACTERISTIC
CARACTERISTIQUES ELECTRIQUES

T_{amb} = 25°C

59C 02498

D T-11-15

Types	V _{ZT} / I _{ZT}		r _{ZT} / I _{ZT}	I _{ZT}	α VZ	I _R / V _R	V _R	I _{ZM}
	min	max	max	(mA)	typ	max	(V)	(mA)
	(V)		(Ω)		(10 ⁻⁴ /°C)	(μA)		
PL 3V3 Z	3,1	3,5	10	100	- 6			320
PL 3V6 Z	3,4	3,8	10	100	- 5,5			290
PL 3V9 Z	3,7	4,1	10	100	- 5			280
PL 4V3 Z	4,0	4,6	7	100	- 4			250
PL 4V7 Z	4,4	5,0	7	100	- 2			215
PL 5V1 Z	4,8	5,4	5	100	1			200
PL 5V6 Z	5,2	6,0	2	100	2,5			190
PL 6V2 Z	5,8	6,6	2	100	3,2			170
PL 6V8 Z	6,4	7,2	2	100	4			155
PL 7V5 Z	7,0	7,9	2	100	4,5	1	2	140
PL 8V2 Z	7,7	8,7	2	100	4,8	1	3,5	130
PL 9V1 Z	8,5	9,6	4	50	5,1	1	3,5	120
PL 10 Z	9,4	10,6	4	50	5,5	1	5	105
PL 11 Z	10,4	11,6	7	50	6	1	5	97
PL 12 Z	11,4	12,7	7	50	6,5	1	7	88
PL 13 Z	12,4	14,1	10	50	6,5	1	7	79
PL 15 Z	13,8	15,6	10	50	7	1	10	71
PL 16 Z	15,3	17,1	15	25	7	1	10	66
PL 18 Z	16,8	19,1	15	25	7,5	1	10	62
PL 20 Z	18,8	21,2	15	25	7,5	1	10	56
PL 22 Z	20,8	23,3	15	25	8	1	12	52
PL 24 Z	22,8	25,6	15	25	8	1	12	47
PL 27 Z	25,1	28,9	15	25	8,5	1	14	41
PL 30 Z	28	32	15	25	8,5	1	14	36
PL 33 Z	31	35	15	25	8,5	1	17	33
PL 36 Z	34	38	40	10	8,5	1	17	30
PL 39 Z	37	41	40	10	9	1	20	28
PL 43 Z	40	46	45	10	9	1	20	26
PL 47 Z	44	50	45	10	9	1	24	23
PL 51 Z	48	54	60	10	9	1	24	21
PL 56 Z	52	60	60	10	9	1	28	19
PL 62 Z	58	66	80	10	9	1	28	16
PL 68 Z	64	72	80	10	9	1	34	15
PL 75 Z	70	79	100	10	9	1	34	14
PL 82 Z	77	87	100	10	9	1	41	12
PL 91 Z	85	96	200	5	9	1	41	12
PL 100 Z	94	106	200	5	9	1	50	11
PL 110 Z	104	116	250	5	9,5	1	50	10
PL 120 Z	114	127	250	5	9,5	1	60	9
PL 130 Z	124	141	300	5	9,5	1	60	8
PL 150 Z	138	156	300	5	9,5	1	75	7
PL 160 Z	153	171	350	5	9,5	1	75	7
PL 180 Z	168	191	350	5	9,5	1	90	6
PL 200 Z	188	212	350	5	10	1	90	5

Forward voltage drop : V_F ≤ 1,5 V @ I_F = 200 mA, T_{amb} = 25°C
 Chute de tension directe

CASE DESCRIPTION
DESCRIPTION DU BOITIER

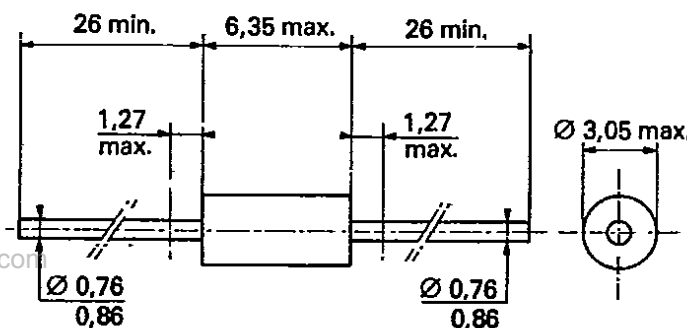

Weight : 0,4 g
 Masse

Marking clear, ring at cathode end
 Marquage en clair, anneau coté cathode

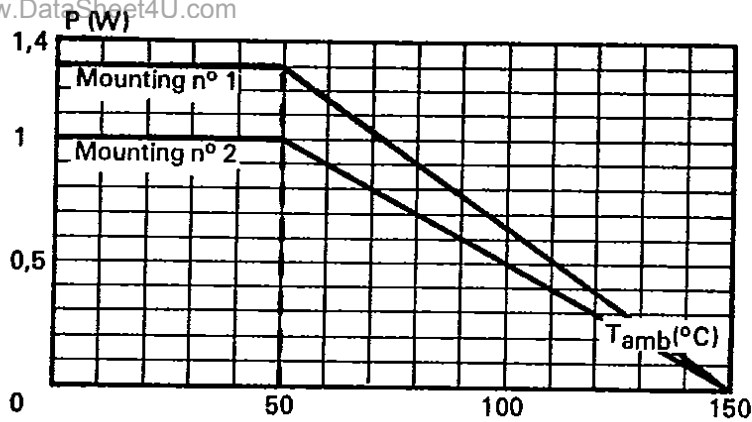

Fig. 1 - Maximum allowable power dissipation versus ambient temperature.

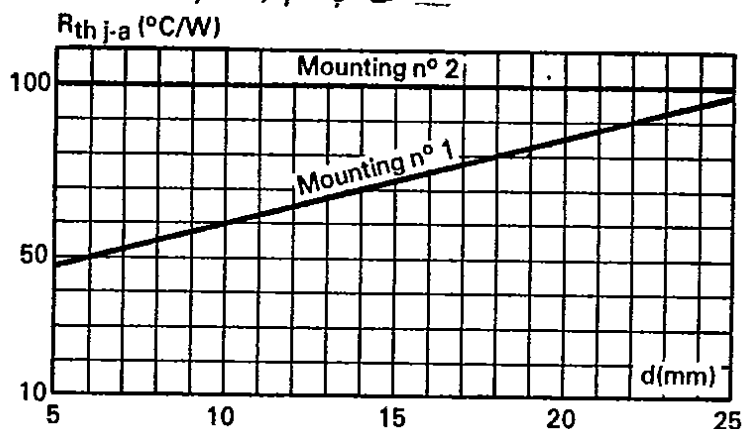
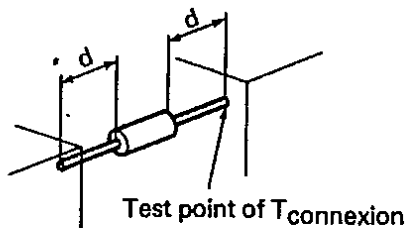

Fig. 2 - Thermal resistance junction-ambient versus lead length (typical values).

Mounting n° 1 :
INFINITE HEATSINK



Mounting n° 2 :
PRINTED CIRCUIT

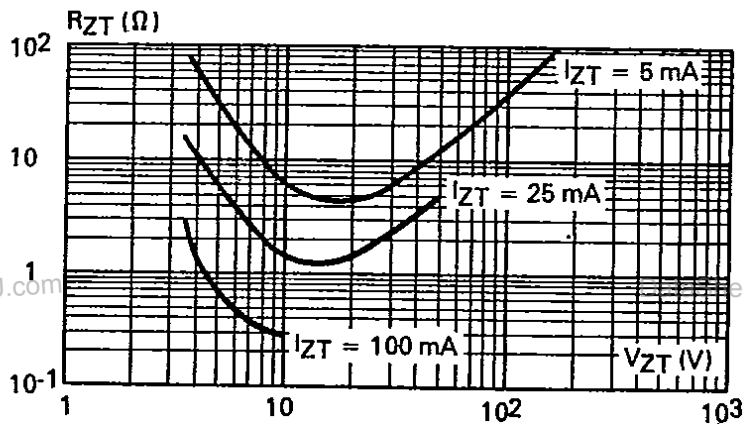
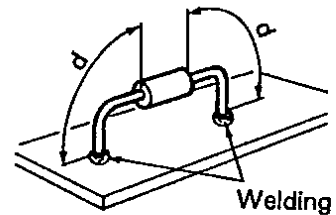

Fig. 3 - Differential resistance R_{ZT} versus V_{ZT} for different currents I_{ZT} (typical values).

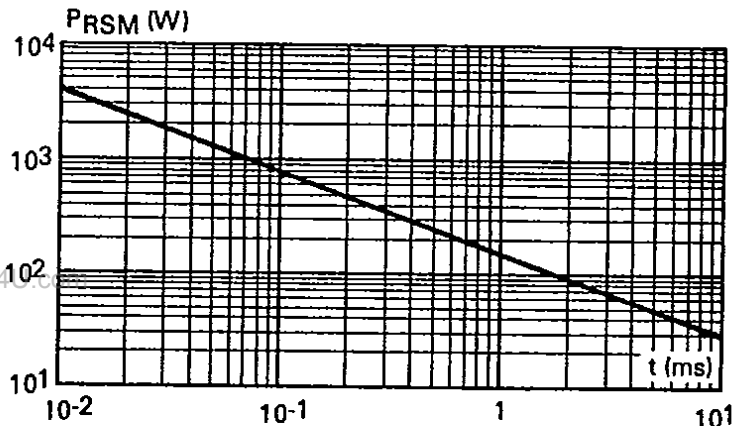

Fig. 4 - Non repetitive surge peak reverse power dissipation PR_{SM} versus pulse duration at T_j initial = 25°C (maximum values).

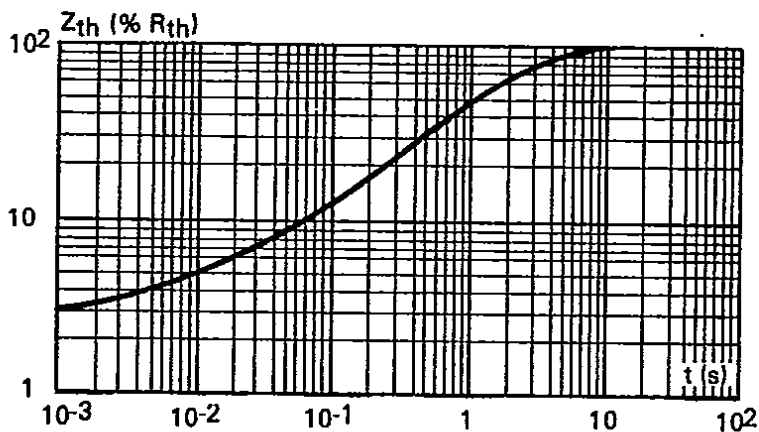

Fig. 5 - Transient thermal impedance junction-connexions Z_{th} (j-a) versus pulse duration for mounting n° 1 with $d = 10$ mm (typical values).

Fig. 6 - Peak forward current I_{FM} versus peak forward voltage drop V_{FM} (typical values).

