

### 1. Features

- Compliant with USB Type-C specification Rev.1.1 DFP mode
- Supports Type-C current 3A advertisement
- Compliant with USB Battery Charging specification Rev.1.2
- Supports Apple divide mode (2.4A)
- Supports Samsung divide mode (2.1A)
- Supports China Telecommunication Industry Standard YD/T 1591-2009
- Built-in gate driver for VBUS power MOSFET
- Discharges VBUS when detached
- Two-ports product (both legacy fast charging port and type-C fast charging port) is possible with only one PL2887 IC
- ESD HBM> 8KV, MM>400V
- Single 5V power supply
- SOT23-8 package

### 2. General Description

The PL2887 is a USB fast charging controller that supports both USB Type-C fast charging and conventional USB fast charging modes at the same time. With USB Type-C charging mode, the PL2887 advertises 3A current through CC1/CC2 pins. With conventional charging mode, the PL2887 supports USB battery charging specification Rev.1.2 (BC1.2), Apple divide mode (2.4A), Samsung divide mode (2.1A), and China Telecommunication Industry Standard YD/T 1591-2009 modes.

To be compliant with USB Type-C specification, the PL2887 has built-in gate driver to control VBUS power MOSFET and also discharges VBUS when detached.

### 3. Target Application

- USB adapters
- USB wall chargers
- USB car chargers
- Power banks

## 4. Block Diagram

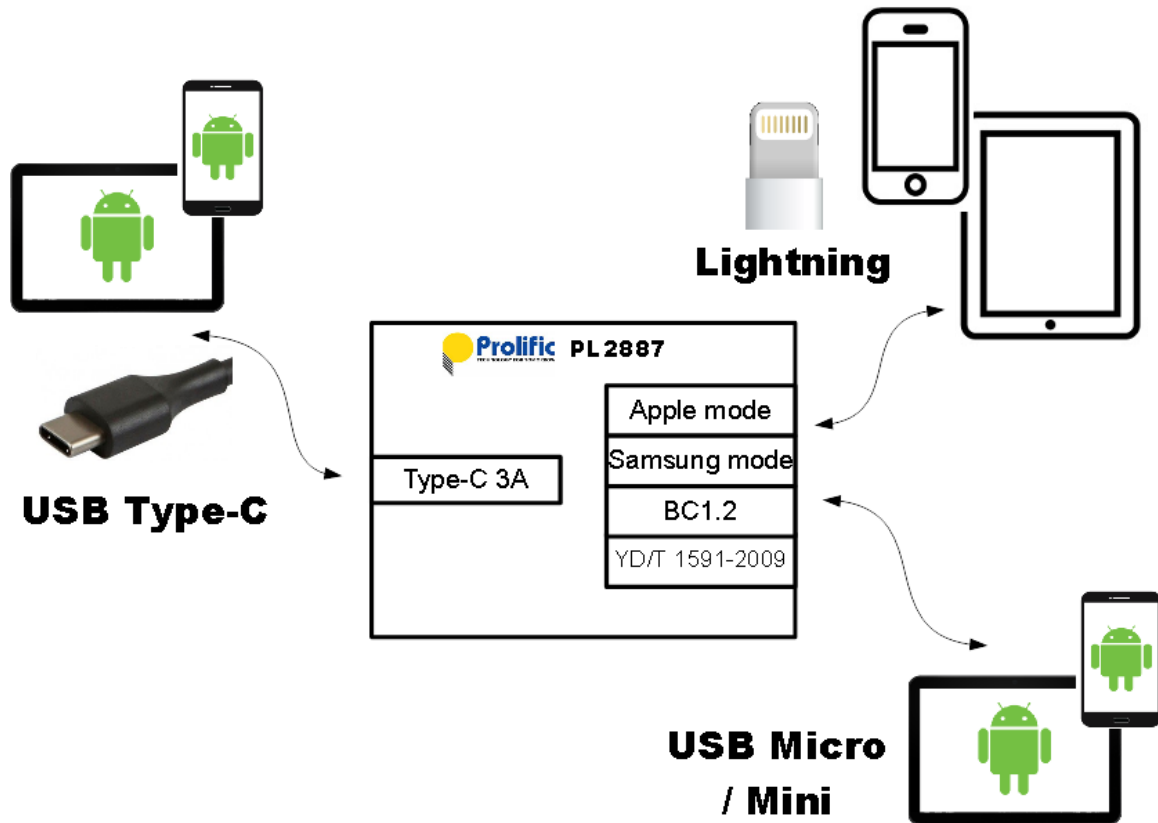

Figure 4-1: PL2887 Block Diagram & Application

## 5. Ordering Information

Table 5-1: Ordering Information

Product Name	Package Type	Ordering Number
PL2887	SOT-23 8pin	Please contact Prolific

## Table of Contents

<b>1. Features</b> .....	<b>1</b>
<b>2. General Description</b> .....	<b>1</b>
<b>3. Target Application</b> .....	<b>1</b>
<b>4. Block Diagram</b> .....	<b>2</b>
<b>5. Ordering Information</b> .....	<b>2</b>
<b>6. Pin Assignment &amp; Description</b> .....	<b>5</b>
6.1 PL2887 Pin Assignment.....	5
6.2 PL2887 Pin Description Table.....	6
<b>7. AC &amp; DC Characteristics</b> .....	<b>7</b>
7.1 Absolute Maximum Ratings .....	7
7.2 Recommended Operating Conditions .....	7
<b>8. Package Outline Diagram</b> .....	<b>8</b>
8.1 Outline Diagram.....	8

## **List of Figures**

Figure 4-1: PL2887 Block Diagram & Application.....	2
Figure 6-1: PL2887 Pin Diagram (Top View).....	5
Figure 8-1: PL2887 Outline Diagram (SOT23-8 pin) .....	8

## **List of Tables**

Table 5-1: Ordering Information .....	2
Table 6-1: PL2887 Pin Assignment.....	6
Table 7-1: Absolute Maximum Ratings.....	7
Table 7-2: Recommended Operating Conditions .....	7

## 6. Pin Assignment & Description

### 6.1 PL2887 Pin Assignment

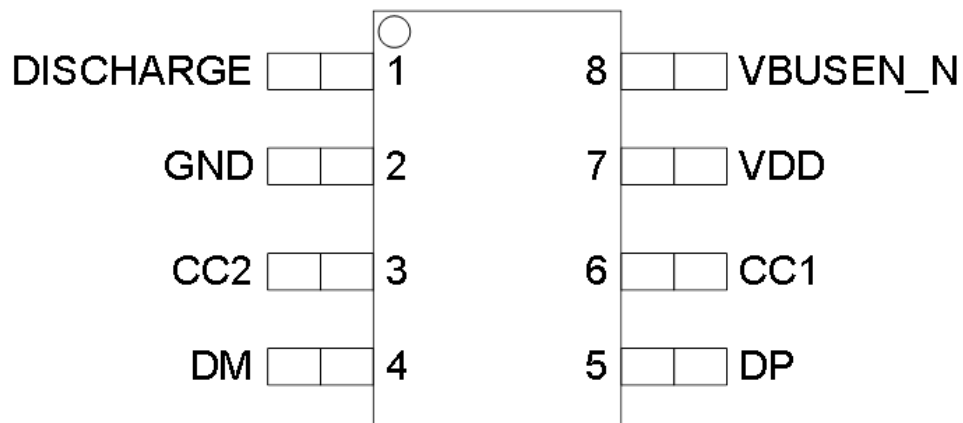

Figure 6-1: PL2887 Pin Diagram (Top View)

## 6.2 PL2887 Pin Description Table

Table 6-1: PL2887 Pin Assignment

Pin #	Pin Name	Pin Type	Pin Description
1	DISCHARGE	AIO	Discharge VBUS when detached
2	GND	P	Ground
3	CC2	AIO	USB type-C CC pin
4	DM	AIO	USB DM pin
5	DP	AIO	USB DP pin
6	CC1	AIO	USB type-C CC pin
7	VDD	P	5V power supply
8	VBUSEN_N	AIO	Gate driver to control power MOS

**Pin Type:**

- AIO – Analog Bi-directional
- P – Power / Ground

## 7. AC & DC Characteristics

### 7.1 Absolute Maximum Ratings

**Table 7-1: Absolute Maximum Ratings**

Symbol	Parameter	Rating	Units
$V_{VDD}$	Power supply of VDD	-0.3 to 5.5	V
$T_{STG}$	Storage temperature	-40 to 150	°C

### 7.2 Recommended Operating Conditions

**Table 7-2: Recommended Operating Conditions**

Symbol	Parameter	Min	Typ	Max	Units
$V_{VDD}$	Power supply of VDD	4.5		5.5	V
$V_{DPDM}$	Operating voltage of DP/DM	3.0	3.3	3.6	V
$V_{CC}$	Operating voltage of CC1/CC2	0		5.5	V
$V_{VBUSEN\_N}$	Operating voltage of VBUSEN_N	0		5.5	V
$V_{DISCHARGE}$	Operating voltage of DISCHARGE	0		5.5	V

## 8. Package Outline Diagram

### 8.1 Outline Diagram

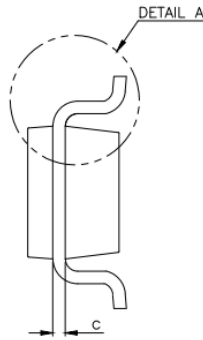
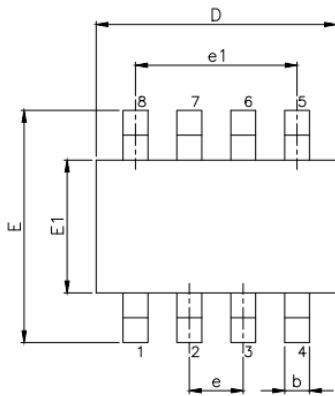

VARIATION(ALL DIMENSIONS SHOWN IN MM)

SYMBOL	MIN.	NOM.	MAX.
A	-	-	1.45
A1	0.00	-	0.15
A2	0.90	1.15	1.30
b	0.22	-	0.38
c	0.08	-	0.22
D	2.90 BSC.		
E	2.80 BSC.		
E1	1.60 BSC.		
e	0.65 BSC.		
e1	1.95 BSC.		
L	0.30	0.45	0.60
L1	0.60 REF.		
L2	0.25 BSC.		
R	0.10	-	-
R1	0.10	-	0.25
$\theta$	0°	4°	8°
$\theta 1$	5°	10°	15°

NOTE :

1. JEDEC OUTLINE : MO-178 BA.

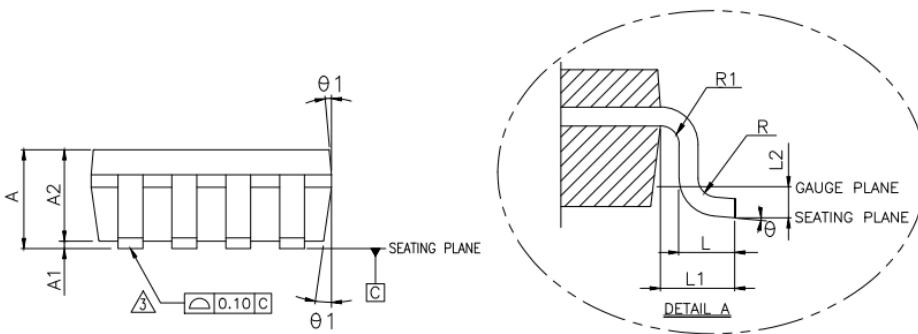

**Figure 8-1: PL2887 Outline Diagram (SOT23-8 pin)**



## **Disclaimer**

All the information in this document is subject to change without prior notice. Prolific Technology Inc. does not make any representations or any warranties (implied or otherwise) regarding the accuracy and completeness of this document and shall in no event be liable for any loss of profit or any other commercial damage, including but not limited to special, incidental, consequential, or other damages.

## **Trademarks**

The Prolific logo is a registered trademark of Prolific Technology Inc. All brand names and product names used in this document are trademarks or registered trademarks of their respective holders.

## **Copyrights**

**Copyright © 2016 Prolific Technology Inc. All rights reserved.**

No part of this document may be reproduced or transmitted in any form by any means without the express written permission of Prolific Technology Inc.