



PMICRO

Powerlink Microelectronics

PL3378

Accurate CC/CV Primary Side PWM Power Switch

Product Description

PL3378 is a high efficiency Primary Side Regulator and highly integrated PWM Power Switch for AC/DC power supply applications. It simplifies conventional CC/CV charger/adaptor designs by eliminating the opto-coupler and secondary control circuitry. Constant output voltage and current regulation is realized as shown in the Fig.1 below.

Multi-mode operations are utilized to achieve low standby power, high efficiency and audio & noise free. PL3378 operates in PFM mode at large load condition, with the load becomes medium or light, the chip operates in Green mode to achieve high efficiency.

PL3378 also offers rich protection features including Cycle-by-Cycle peak current limiting, UVLO, OTP, load OVP, and VDD over voltage.

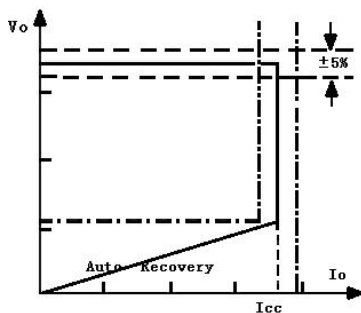
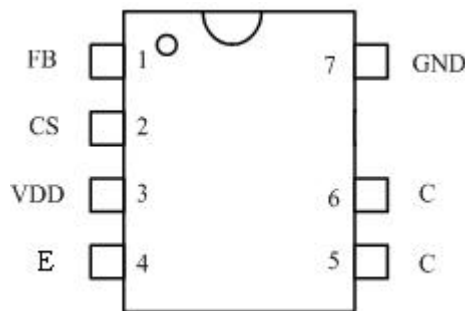

Fig.1. Typical CC/CV Curve

Pin Configuration



PL3378

Key Features

- Built-in Integrated Power BJT
- Accurate Constant Current Regulation at Universal AC input
- Eliminates Opto-coupler and all Secondary CC/CV Control Circuitry
- Built-in Line Compensation for Tighter CC/CV Regulation
- Built-in Compensation for Transformer Inductance Tolerances
- Adjustable Output Cable Compensation
- Adaptive Multi-mode PFM Control for Improving Efficiency
- Low Start-up Current
- Built-in Leading Edge Blanking (LEB)
- Cycle-by-Cycle Current Limiting
- VDD Under Voltage Lockout and VDD over voltage protection
- Built-in Short Circuit Protection and Output Overvoltage Protection
- Over temperature protection

Applications

- AC/DC power supply applications
- Cell Phone Charger
 - Small Power Adaptor/Charger
 - LED Driver
 - Standby Supply for Consumer Electronics



1 Overview

PL3378 is a high efficiency Primary Side Regulator and highly integrated PWM Power Switch for AC/DC power supply applications. It simplifies conventional CC/CV charger/adaptor designs by eliminating the opto-coupler and secondary control circuitry. Constant output voltage and current regulation is realized

Multi-mode operations are utilized to achieve low standby power, high efficiency and audio & noise free. PL3378 operates in PFM mode at large load condition, with the load becomes medium or light, the chip operates in Green mode to achieve high efficiency. This

green-mode function assists the power supply meeting the power conservation requirement.

A complete set of integrated protection functions allows PL3378 to protect against all fault conditions including Cycle-by-Cycle peak current limiting, VDD UVLO, and VDD_Clamp. The switch continues attempting start-up until the fault condition is removed.

PL3378 is offered in SOP7 package.

2 Features

- Built-in Integrated Power BJT
- Accurate Constant Current Regulation at Universal AC input
- Eliminates Opto-coupler and all Secondary CC/CV Control Circuitry
- Built-in Line Compensation for Tighter CC/CV Regulation
- Built-in Compensation for Transformer Inductance Tolerances
- Output Cable Compensation
- Adaptive Multi-mode PFM Control for Improving Efficiency
- Low Start-up Current
- Built-in Short Circuit Protection
- Built-in open Circuit Protection
- LEB
- OCP
- VDD_OVP
- UVLO
- OTP

3 Pin Diagrams

The pin map is shown as below for SOP7

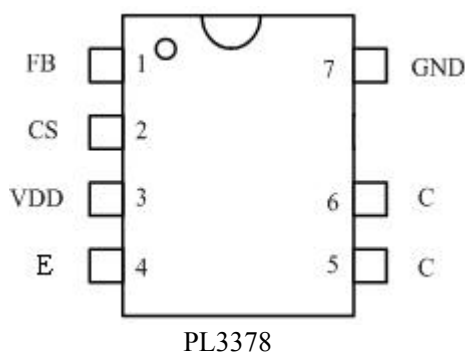

4 Pin Description

Pin	Description
VDD	IC power supply.
FB	Through two dividing resistors connecting to the bias winding, this pin could get the information of output to realize the CC/CV regulation.
CS	This pin could detect the primary current by the voltage of sensing resistor connected from CS to GND.
C	HV BJT collector Pin. This pin is connected to the primary lead of the transformer.
E	HV BJT collector Pin.
GND	IC ground.

5 Absolute Maximum Ratings

Absolute maximum ratings are the parameter values or ranges which can cause permanent damage and affect device reliability if exceeded.

Parameter	Symbol	Value	Units
DC Supply Voltage Range(pin1)	VDD	-0.3 to VDD clamp	V
CS Input(pin4)	CS	-0.3 to 5	V
FB Input(pin3)	FB	-0.3 to 5	V
Maximum Junction Temperature	Tjmax	150	°C
Storage Temperature	Tsto	-55 to 150	°C
Lead Temperature(Soldering,10secs)	Tlea	260	°C

Note: These are stress ratings only. Stress beyond these limits may cause permanent damage to the device. Functional operation of the device at these or any conditions beyond those indicated under Recommended Operating Conditions is not implied. Exposure to absolute maximum rated conditions for extended periods of time may affect device reliability.

8 Electrical Characteristics

(VDD =21V, T_A = 25°C, unless otherwise specified)

Parameter	Symbol	Test Conditions	Min	Typ	Max	Unit
Supply Voltage (VDD) Section						
VDD start current	IDD_st	VDD=UVLO_OFF-1V		5	20	uA
Operation current	Idd_static	Light load		0.6	1	mA
VDD under voltage lockout OFF	UVLO_OFF	VDD rise	14	17.5	21	v
VDD under voltage lockout ON	UVLO_ON	VDD_fall	3.5	4.5	5.5	v
VDD over voltage	VDD_OVP			27		v
Current sense Section						
Turn on LEB Time	TLEB			500		ns
Over Current Threshold	Vocp			550		mV
OCP propagation delay	Td_oc			100		ns
FB Section						
Reference for feedback threshold	Vref_EA		2.46	2.5	2.54	V
Minimum off time	Toff_min			2		us
Minimum frequency	Fosc_min			80		Hz
Maximum cable compensation current	Icable_max			44		uA
Output over voltage threshold	Vfb_ovp			3		V
Over Temperature Protection (OTP)						
Protection trigger point	T_otp			151		°C
Protection recovery point	T_otp_rec			139		°C
PL3378(SOP7) Power BJT						
Collector-emitter breakdown voltage	Vceo	Ic=10mA	400			V
Collector-base breakdown voltage	Vcbo	Ic=1mA	700			V

9 Application

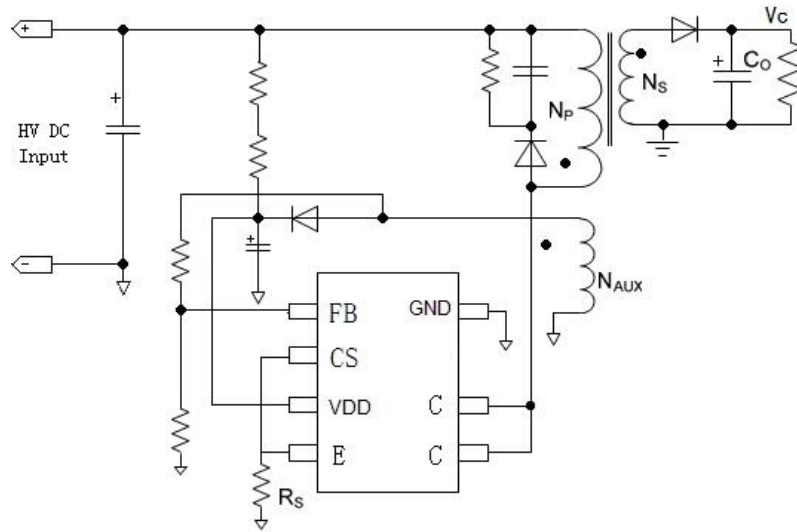

Application Notes

PL3378 provides a very effective solution for low power adaptor/charger applications. The innovative CV and CC control can remove the need for secondary feedback circuitry while achieving excellent CC/CV performance and meeting very strict requirements.

9.1 Startup & Operating Current

PL3378 has very slight startup current, thus the larger value startup resistor and smaller VDD capacitor can be used to minimize the power loss in application.

The operating current of PL3378 is also very low. Together with PFM control features we could get high efficiency especially in light load.

9.2 Under Voltage Lockout (UVLO)

An UVLO detector is implemented in it to detect the voltage on the VDD pin. It would assure the supply voltage enough to turn on the PWM controller and further to drive the power BJT. A hysteresis is built in to prevent the shutdown from the voltage dip during startup. The turn-on and turn-off threshold level are set at 17.5 V and 4.5 V, typically.

9.3 Realization of CC/CV

The CC/CV control is based on the system

working in DCM.

In the DCM fly-back converter, the output voltage can be sensed via the auxiliary winding. During MOSFET turn-on time, the current in the primary winding ramps up. When MOSFET turns off, the primary current transfers to the secondary at the amplitude of

$$I_{Spk} = \frac{N_P}{N_S} \cdot I_{Ppk} \quad (1)$$

I_{Ppk} is the current in the primary winding at the point BJT turns off.

Through coupling between the secondary and auxiliary winding the output voltage is given by

$$V_o = \frac{N_S \cdot V_{aux} - \Delta V}{N_{aux}} \quad (2)$$

Where V_{aux} is the voltage of the auxiliary winding and ΔV indicates the drop voltage of the output diode.

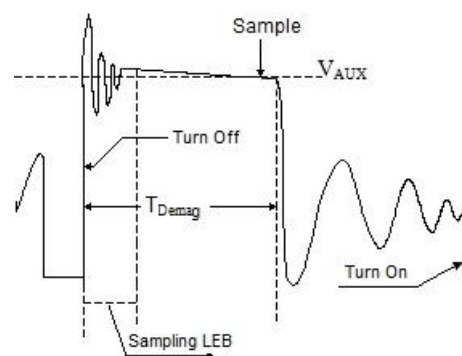

Fig.2. Voltage of Auxiliary-winding Waveform

Via a resistor divider connected between the auxiliary winding and FB, the auxiliary voltage is sampled based on the internal timing control. Through the built-in error amplifier the sampled voltage could be regulated at a preset level, thus constant output voltage can be achieved.

During the CC mode of operation PL3378 will regulate the output current at a constant level regardless of the output voltage, while avoiding continuous conduction mode.

9.4 Adjustable CC Point and Output Power

In application of AC/DC power supply application, we could change the Rs to get different CC points and the maximum output power only using one model. The larger Rs, the smaller CC point is, and the smaller output power becomes.

9.5 Switching Frequency and Lm Tolerance Compensation

The system load condition and the operation mode decide the switching frequency of PL3378. The maximum switching frequency is set by system design. In DCM assuming the efficiency to 100%, the output power is given by

$$P_o = \frac{1}{2} L_m f_{sw} I_{Ppk}^2 = V_o \bullet I_o \quad (3)$$

Where Lm indicates the inductance of the primary winding and I_{Ppk} is the peak current of the primary winding.

Refer to the equation 3, the change of Lm results in the change of Po and the constant output current in the CC mode. The tolerance of Lm will make CC worse in mass production. To

smooth it away, the switching frequency is locked by an internal loop such that the switching frequency is

$$f_{sw} = 4/(7 \cdot T_{demag}) \quad (4)$$

Where T_{demag} is the discharge time of inductance. Since T_{demag} is inversely proportional to the inductance, the error of current in CC mode and max output power caused by the variation of inductance will be eliminated.

9.6 Adjustable Cable Drop Compensation

Built-in cable drop compensation is used to get better load regulation.

Without compensation of cable drop, the voltage at the end of the cable between no load and full load will not be the same caused by cable drop. To get better load regulation, an offset voltage is generated at FB pin by an internal current flowing into the resistor divider. The current is proportional to the switching off time, as a result, it is inversely proportional to the output load current, thus the drop due to the cable loss can be compensated.

In different applications using different cables, we could adjust the resistance of the divider connected to the FB pin. The larger impedance of the cable, the larger divider will be used.

9.7 Protection Control

PL3378 has built-in rich protection features including Cycle-by-Cycle Current Limiting, VDD over voltage, Under Voltage Lockout on VDD, Output OVP and OTP Protection.

PL3378 is shut down when VDD drops below the UVLO (ON) limit, and the power converter enters the power on start-up sequence thereafter.

10 Packaging Information

SOP7Packaging

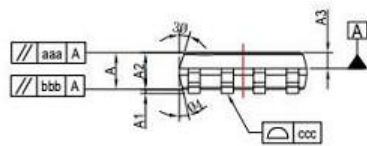

Top View

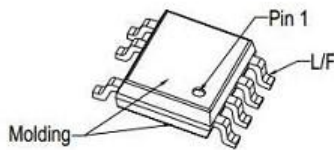

ISO View

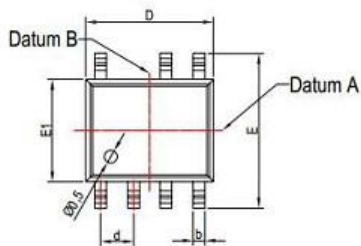

Front View

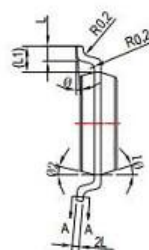

Right View

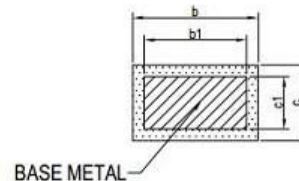

SECTION A-A

Dimensional References unit:mm

Ref.	MIN	NOM	MAX	Ref.	MIN	NOM	MAX
A	1.35	1.55	1.75	E1	3.8	3.9	4.0
A1	0.10	0.15	0.25	L	0.45	0.60	0.80
A2	1.25	1.40	1.65	L1	1.04 REF		
A3	0.5	0.6	0.7	L2	0.25 BSC		
b	0.38	/	0.51	R	0.07	/	/
b1	0.37	0.42	0.47	R1	0.07	/	/
c	0.17	/	0.25	φ	0°	/	8°
c1	0.17	0.20	0.23	φ1	15°	17°	19°
D	4.8	4.9	5.0	φ2	11°	13°	15°
d	1.27 BSC			φ3	15°	17°	19°
E	5.8	6.0	6.2	φ4	11°	13°	15°
aaa	0.10			bbb	0.10		
ccc	0.10						

11 Important Notice

POWERLINK reserves the right to make changes or corrections to its products at any time without notice. Customers should verify the datasheets are current and complete before placing orders.