

**FEATURES**

- Full CMOS output swing with 40-mA output drive capability, 25-mA output drive at TTL level.
- Advanced, low power, sub-micron CMOS processes.
- 25MHz fundamental crystal or clock input.
- 4 outputs at 50MHz, 2 outputs selectable at 25MHz or 125MHz, 1 output selectable at 25MHz or 100MHz.
- 2 SDRAM selectable frequencies of 66.6, 75, 83.3, 100MHz (Double Drive Strength).
- All non SDRAM outputs can be disabled (tri-state)
- Spread spectrum technology selectable for EMI reduction from  $\pm 0.5\%$ ,  $\pm 0.75\%$  for SDRAM and 100MHz output.
- Zero PPM synthesis error in all clocks.
- Ideal for Network switches.
- 3.3V operation.
- Available in 24-Pin 150mil SSOP.

**PIN CONFIGURATION**

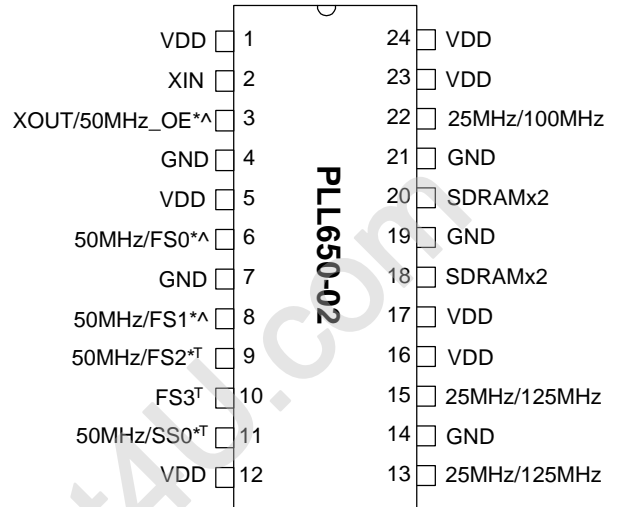

**Note:** SDRAMx2: Double Drive strength. T: Tri-Level input ^: Internal pull-up resistor. \*: Bi-directional pin (input value is latched upon power-up).

**DESCRIPTIONS**

The PLL 650-02 is a low cost, low jitter, and high performance clock synthesizer. With PhaseLink's proprietary analog Phase Locked Loop techniques, the chip accepts 25 MHz crystal, and produces multiple output clocks for networking chips, PCI devices, SDRAM, and ASICs, with double drive strength for its SDRAM outputs.

**FREQUENCY TABLE**

FS1	FS0	SDRAM
0	0	100MHz <sup>SST</sup>
0	1	75MHz <sup>SST</sup>
1	0	83.3MHz <sup>SST</sup>
1	1	66.6MHz <sup>SST</sup>

FS3	Pin 13, 15	FS2	Pin 22
0	Disable	0	25MHz
M	125MHz	M	Disable
1	25MHz	1	100MHz <sup>SST</sup>

FS(2:3): Tri-level inputs.  
SST: SST modulation applied (see selection table)

**BLOCK DIAGRAM**

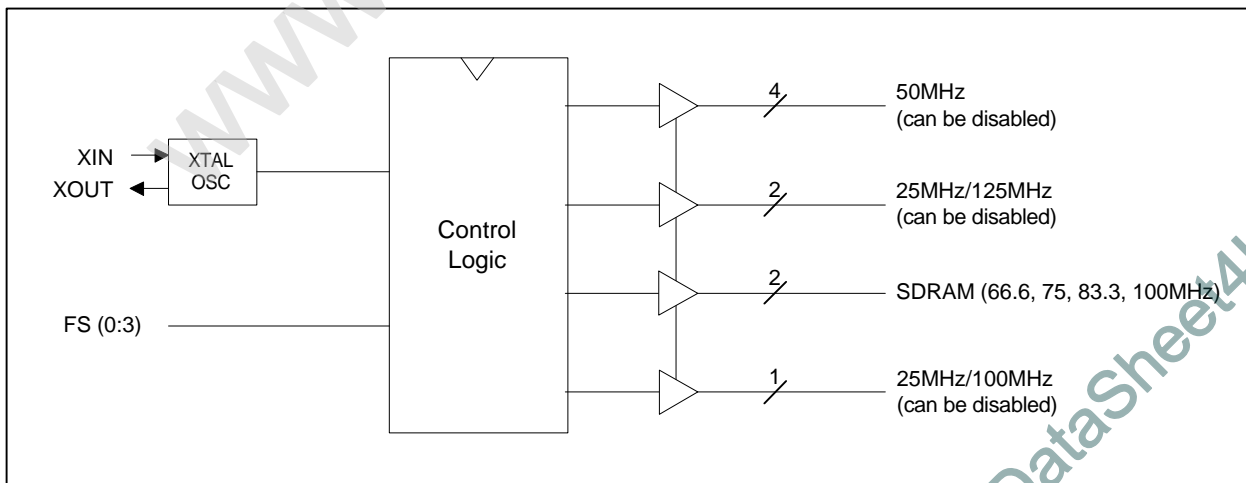

## Low EMI Network LAN Clock

### PIN DESCRIPTIONS

Name	Number	Type	Description
XIN	2	I	25MHz fundamental crystal input (20pF $C_L$ parallel resonant). $C_L$ have been integrated into the chip. No external $C_L$ capacitor is required.
XOUT/50MHz_OE	3	B	Crystal connection pin. At power-up, this pin latches 50MHz_OE (output enable selector for all 50MHz outputs. Disabled when 50MHz_OE is logical zero. Has 120k $\Omega$ internal pull up resistor.
50MHz/FS(0:2) 50MHz/SS0	6,8,9,11	B	Bi-directional pins. 50MHz outputs. These pins latch FS(0:2) and SS0 at power-up. 60k $\Omega$ internal pull up resistors on pins 6 and 8.
FS3	10	I	Tri-level input pin. FS3 input put.
25MHz/125MHz	13,15	O	25MHz (reference) or 125MHz outputs. Can be disabled with FS3 = 1.
SDRAMx2	18,20	O	SDRAM outputs with double drive strength determined by FS(0:1) value.
25MHz/100MHz	22	O	25MHz (reference) or 100MHz output. Can be disabled with FS2 = M.
VDD	1,5,12, 16,17,23,24	P	3.3V power supply.
GND	4,7,14,19,21	P	Ground.

### SPREAD SPECTRUM SELECTION TABLE

SS0	SST modulation
0	$\pm 0.75\%$ center
M	OFF
1	$\pm 0.5\%$ center

### FUNCTIONAL DESCRIPTION

#### Selectable spread spectrum and output frequencies

The PLL650-02 provides selectable spread spectrum modulation and selectable output frequencies. Selection is made by connecting specific pins to a logical "zero" or "one", or by leaving them not connected (tri-level inputs or internal pull-up) according to the frequency and spread spectrum selection tables shown on pages 1 and 2 respectively.

In order to reduce pin usage, the PLL650-02 uses tri-level input pins. These pins allow 3 levels for input selection: namely, 0 (Connect to GND), 1 (Connect to VDD), M (Do not connect). Thus, unlike the two-level selection pins, the tri-level input pins are in the "M" (mid) state when not connected. In order to connect a tri-level pin to a logical "zero", the pin must be connected to GND. Likewise, in order to connect to a logical "one" the pin must be connected to VDD.

Pin 3 (XOUT/50MHz\_OE) is a bi-directional pin used to disable the 50MHz output pins. Pin 6 (FS0) and pin 8 (FS1) are bi-directional pins used to select the SDRAM output frequency upon power-up. Pin 9 (FS2) and pin 11 (FS3) are tri-level bi-directional pins used to select the output frequency of pins 13, 15 and 22, as shown in the frequency table on page 1. After the input signals have been latched, pins 6, 8, 9, and 11 serve as 50 MHz frequency outputs.

**Low EMI Network LAN Clock**

**Connecting a bi-directional pin**

A bi-directional pin serves as input upon power-up, and as output as soon as the inputs have been latched. The value of the input is latched-in upon power-up. Depending on the pin (see pin description), the input can be tri-level or a standard two-level. Unlike unidirectional pins, bi-directional pins cannot be connected directly to GND or VDD in order to set the input to "0" or "1", since the pin also needs to serve as output. In the case of two level input pins, an internal pull-up resistor is present. This allows a default value to be set when no external pull down resistor is connected between the pin and GND (by definition, a tri-level input has a the default value of "M" (mid) if it is not connected). In order to connect a bi-directional pin to a non-default value, the input must be connected to GND or VDD through an external pull-down/pull-up resistor. **Note:** when the output load presents a low impedance in comparison to the internal pull-up resistor, the internal pull-up resistor may not be sufficient to pull the input up to a logical "one", and an external pull-up resistor may be required.

For bi-directional inputs, the external loading resistor between the pin and GND has to be sufficiently small (compared to the internal pull-up resistor) so that the pin voltage be pulled below 0.8V (logical "zero"). In order to avoid loading effects when the pin serves as output, the value of the external pull-down resistor should however be kept as large as possible. In general, it is recommended to use an external resistor of around one sixth to one quarter of the internal pull-up resistor (see Application Diagram). **Note:** when the output is used to drive a load presenting an small resistance between the output pin and VDD, this resistance is in essence connected in parallel to the internal pull-up resistor. In such a case, the external pull-down resistor may have to be dimensioned smaller to guarantee that the pin voltage will be low enough achieve the desired logical "zero". This is particularly true when driving 74FXX TTL components.

**APPLICATION DIAGRAM**

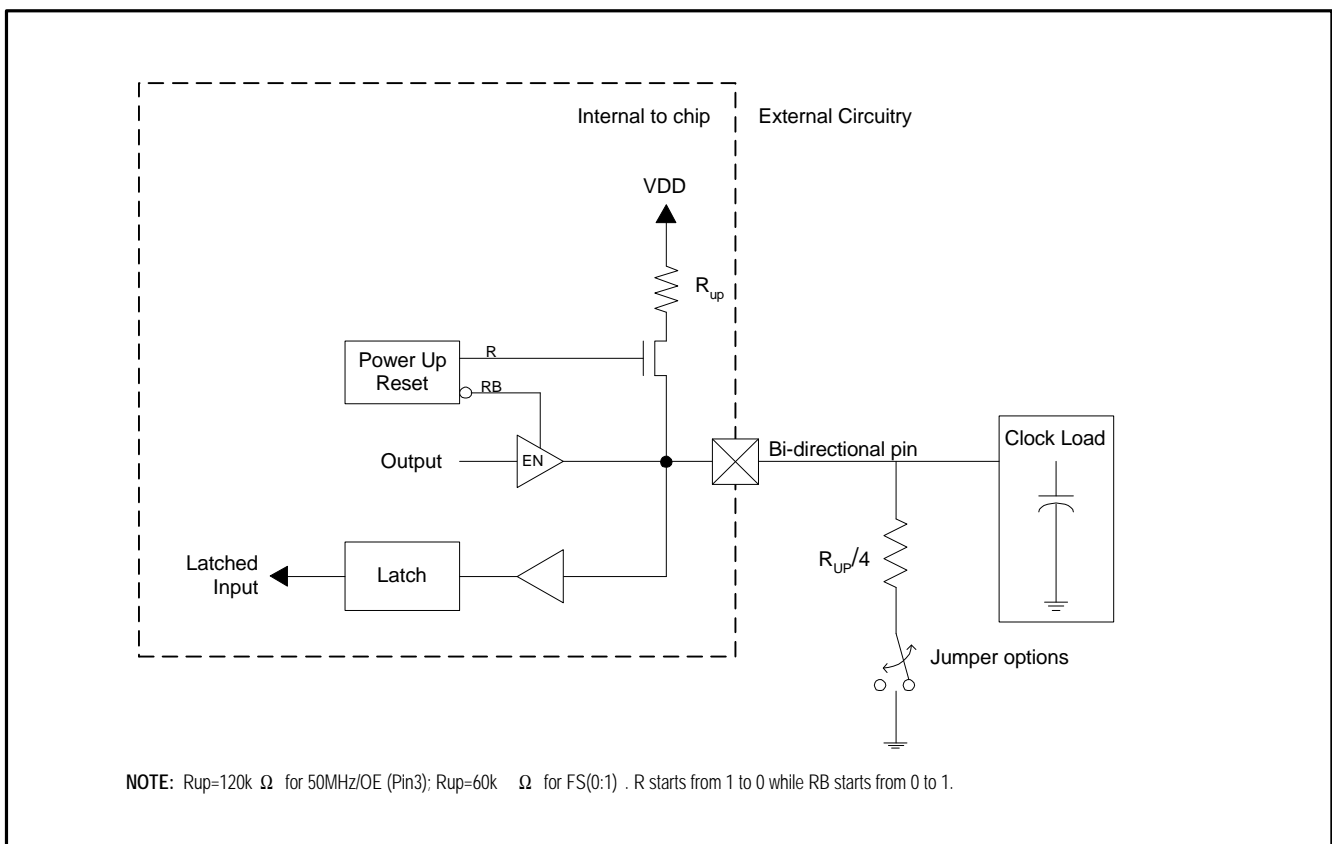

### Electrical Specifications

#### 1. Absolute Maximum Ratings

PARAMETERS	SYMBOL	MIN.	MAX.	UNITS
Supply Voltage Range	$V_{CC}$	-0.5	7	V
Input Voltage Range	$V_I$	-0.5	$V_{CC}+0.5$	V
Output Voltage Range	$V_O$	-0.5	$V_{CC}+0.5$	V
Soldering Temperature			260	°C
Storage Temperature	$T_S$	-65	150	°C
Ambient Operating Temperature		0	70	°C

Exposure of the device under conditions beyond the limits specified by Maximum Ratings for extended periods may cause permanent damage to the device and affect product reliability. These conditions represent a stress rating only, and functional operations of the device at these or any other conditions above the operational limits noted in this specification is not implied.

#### 2. AC Specification

PARAMETERS	CONDITIONS	MIN.	TYP.	MAX.	UNITS
Input Frequency		10	25	27	MHz
Output Rise Time	0.8V to 2.0V with no load			1.5	ns
Output Fall Time	2.0V to 0.8V with no load			1.5	ns
Duty Cycle*	At VDD/2	45	50	55	%
Max. Absolute Jitter	Short term		±150		ps
Max. Jitter, cycle to cycle				80	ps

\*: in case SDRAM output is selected to be 83.3MHz, the duty cycle of output pin 22 will be 40%-60% if its output frequency is selected to be 100MHz (FS2=1). In all other situations, pin 22 will also have a 50%-50% typical duty cycle.

## Low EMI Network LAN Clock

### 3. DC Specification

PARAMETERS	SYMBOL	CONDITIONS	MIN.	TYP.	MAX.	UNITS
Operating Voltage	VDD		3.13		3.47	V
Input High Voltage	V <sub>IH</sub>			VDD/2		V
Input Low Voltage	V <sub>IL</sub>			VDD/2	VDD/2 - 1	V
Input High Voltage	V <sub>IH</sub>	For all Tri-level input	VDD-0.5			V
Input Low Voltage	V <sub>IL</sub>	For all Tri-level input			0.5	V
Input High Voltage	V <sub>IH</sub>	For all normal input	2			V
Input Low Voltage	V <sub>IL</sub>	For all normal input			0.8	V
Output High Voltage	V <sub>OH</sub>	I <sub>OH</sub> = -25mA	2.4			V
Output Low Voltage	V <sub>OL</sub>	I <sub>OL</sub> = 25mA			0.4	V
Output High Voltage At CMOS Level	V <sub>OH</sub>	I <sub>OH</sub> = -8mA	VDD-0.4			V
Operating Supply Current	I <sub>DD</sub>	No Load		35		mA
Short-circuit Current	I <sub>S</sub>			±100		mA
Nominal output current*	I <sub>out</sub>	CMOS output level	35	40		mA
Nominal output current*	I <sub>out</sub>	TTL output level	20	25		mA
Internal pull-up resistor	R <sub>up</sub>	Pins 6,8		60		kΩ
Internal pull-up resistor	R <sub>up</sub>	Pin 3		120		kΩ

\*: SDRAM output strengths are doubled (i.e. min. CMOS level is 70mA, typ. CMOS level is 80mA)

**PACKAGE INFORMATION**

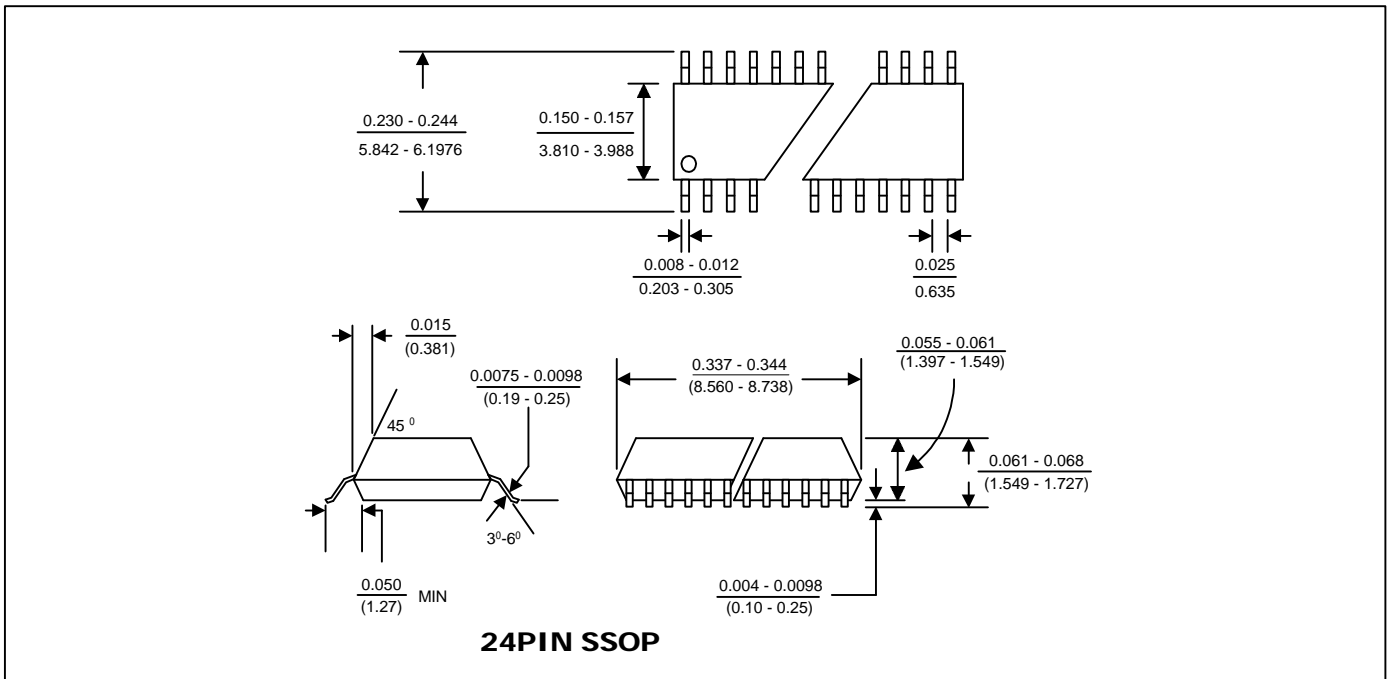

**ORDERING INFORMATION**

**For part ordering, please contact our Sales Department:**  
47745 Fremont Blvd., Fremont, CA 94538, USA  
Tel: (510) 492-0990 Fax: (510) 492-0991

**PART NUMBER**

The order number for this device is a combination of the following:  
Device number, Package type and Operating temperature range

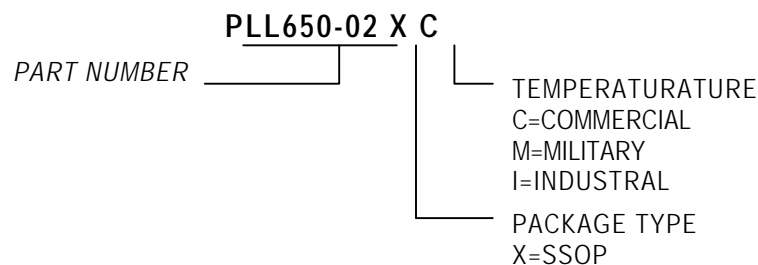

PhaseLink Corporation, reserves the right to make changes in its products or specifications, or both at any time without notice. The information furnished by Phaselink is believed to be accurate and reliable. However, PhaseLink makes no guarantee or warranty concerning the accuracy of said information and shall not be responsible for any loss or damage of whatever nature resulting from the use of, or reliance upon this product.

**LIFE SUPPORT POLICY:** PhaseLink's products are not authorized for use as critical components in life support devices or systems without the express written approval of the President of PhaseLink Corporation.