

Version : 0.1

TECHNICAL SPECIFICATION

MODEL NO. : PM042OX1

Customer's Confirmation

Customer \_\_\_\_\_

By \_\_\_\_\_

PVI's Confirmation

Confirmed By \_\_\_\_\_

Prepared By \_\_\_\_\_

**FOR MORE INFORMATION:**

AZ DISPLAYS, INC.  
75 COLUMBIA, ALISO VIEJO, CA, 92656  
[Http://www.AZDISPLAYS.com](http://www.AZDISPLAYS.com)

Date: Oct 08, 2004

This technical specification is subject to change without notice.

Please return 1 copy with your signature on this page for approval.

The information contained herein is the exclusive property of Prime View International Co., Ltd. and shall not be distributed, reproduced, or disclosed in whole or in part without prior written permission of Prime View International Co., Ltd.

---

**TECHNICAL SPECIFICATION****CONTENTS**

<b>NO.</b>	<b>ITEM</b>	<b>PAGE</b>
-	Cover	1
-	Contents	2
1	Application	3
2	Features	3
3	Mechanical Specifications	3
4	Mechanical Drawing of TFT-LCD module	4
5	Input / Output Terminals	6
6	Absolute Maximum Ratings	12
7	Electrical Characteristics	12
8	Pixel Arrangement	13
9	Display Color and Gray Scale Reference	14
10	Block Diagram	15
11	Interface Timing	16
12	Power On Sequence	21
13	Optical Characteristics	21
14	Handling Cautions	25
15	Reliability Test	26
16	Indication of Lot Number Label	26
17	Packing Diagram	27
-	Revision History	28

## 1. Application

This data sheet applies to a color TFT LCD module, PM042OX1.

PM042OX1 module applies to Car Audio, which requires high quality flat panel display. If you must use in severe reliability environment, please don't extend over PVI's reliability test conditions.

If you use PM042OX1, Prime View advises your systems use PVI's timing controller IC (PVI-2002A) which will generate proper timing signals to control PM042OX1.

## 2. Features

- . Resolution: 320 \* RGB \* 96
- . Amorphous silicon TFT LCD panel with back-light unit
- . Pixel in stripe configuration
- . Thin and light weight
- . Display Colors : 262,144 colors
- . Optimum Viewing Direction : 6 o'clock
- . TTL interface
- . **Wide viewing angle**

## 3. Mechanical Specifications

Parameter	Specifications	Unit
Screen Size	4.2 (diagonal)	inch
Display Format	320×(R, G, B)×96	dot
Display Colors	262,144	
Active Area	103.68(H)×25.10(V)	mm
Pixel Pitch	0.324(H)×0.261(V)	mm
Pixel Configuration	Stripe	
Outline Dimension	119.9(W)*38.30(H)*6.6(D) (Typ.)	mm
Weight	<b>TBD</b>	g
Back-light	CCFL, 1 tube	
Surface treatment	Anti-glare and <b>Wide View Film</b>	
Display mode	Normally white	

**4.Mechanical Drawing of TFT-LCD Module**  
**Outline Drawing : Front View (unit : mm)**

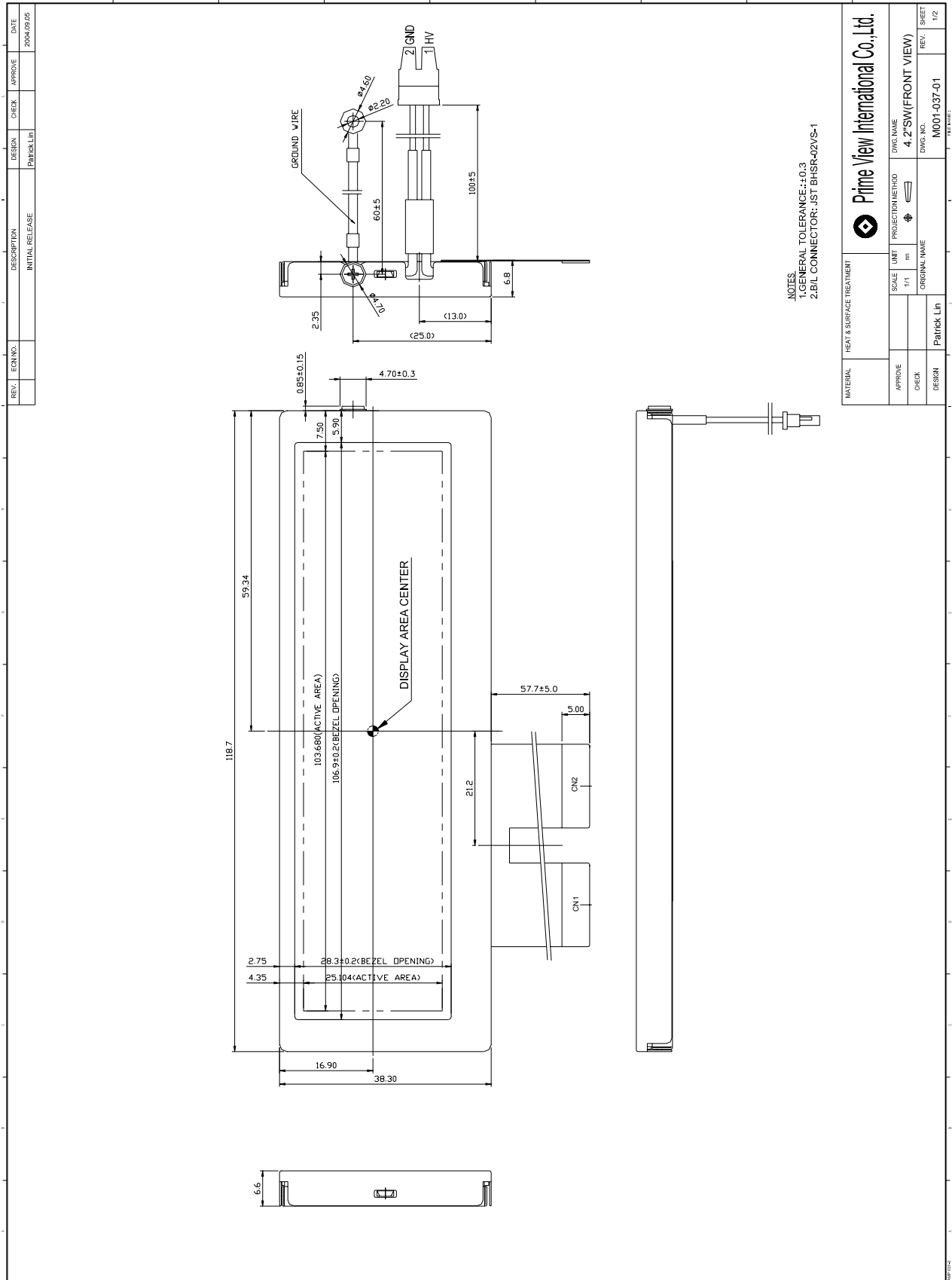

**Outline Drawing : Rear View (unit : mm)**

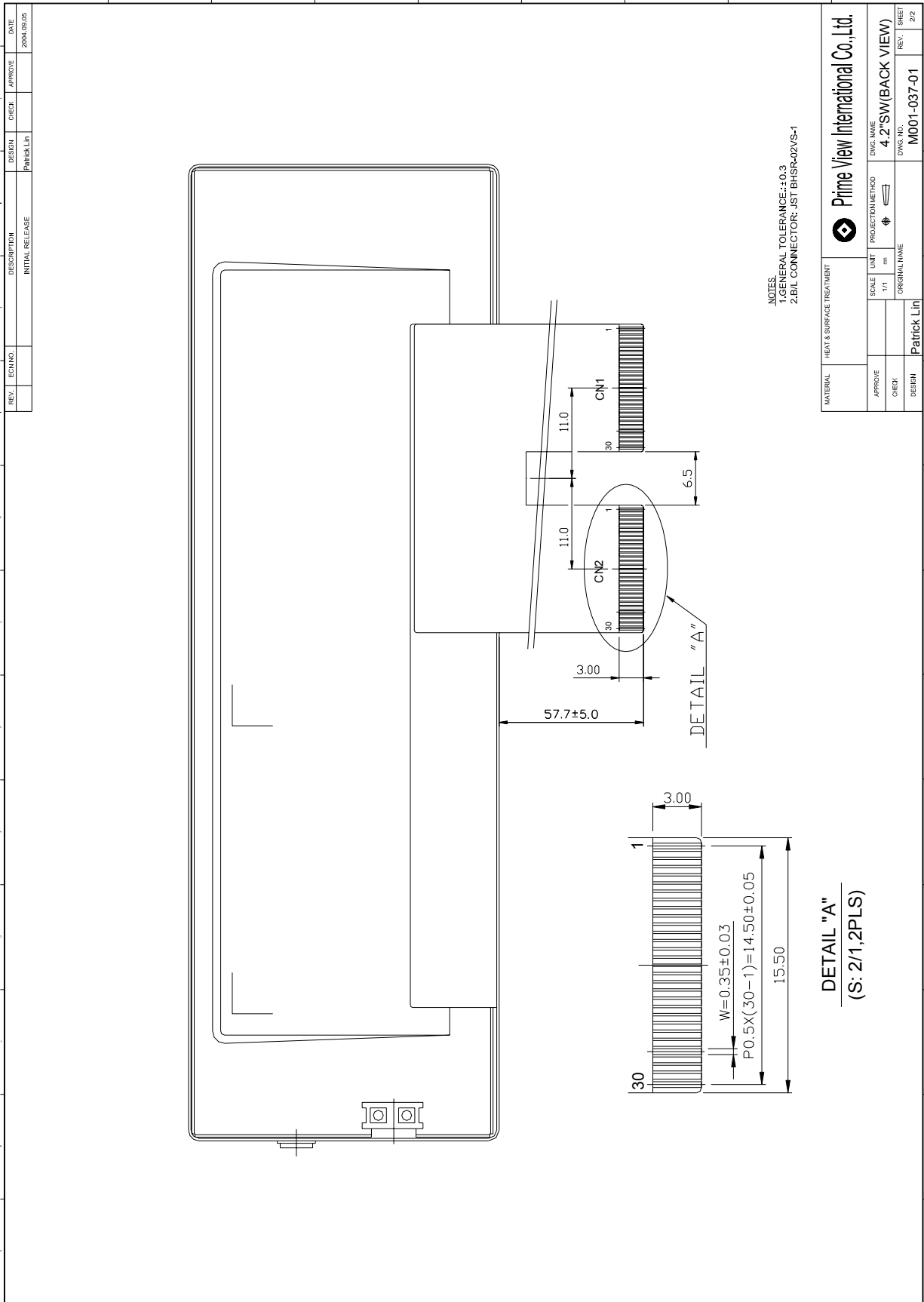

**5. Input / Output Terminals**
**5-1) TFT-LCD Panel Driving**

Connector type: ELCO, 6210-30PIN, PIN No 30 pins, pitch=0.5mm

**CN 1**

Pin No.	Symbol	I/O	Function	Remark
1	DIO1	I/O	Horizontal Start Pulse Signal Input or Output	Note 5-1
2	VSS1	I	Ground	
3	VDD1	I	Power Supply	
4	CLK	I	Horizontal Shift Clock	
5	VSS1	I	Ground	
6	R/L	I	Right / Left selection	Note 5-1
7	R0	I	Red Data (LSB)	
8	R1	I	Red Data	
9	R2	I	Red Data	
10	R3	I	Red Data	
11	R4	I	Red Data	
12	R5	I	Red Data (MSB)	
13	VSS1	I	Ground	
14	G0	I	Green Data (LSB)	
15	G1	I	Green Data	
16	G2	I	Green Data	
17	G3	I	Green Data	
18	G4	I	Green Data	
19	G5	I	Green Data (MSB)	
20	VSS1	I	Ground	
21	B0	I	Blue Data (LSB)	
22	B1	I	Blue Data	
23	B2	I	Blue Data	
24	B3	I	Blue Data	
25	B4	I	Blue Data	
26	B5	I	Blue Data (MSB)	
27	LD	I	Load output signal	Note 5-2
28	REV	I	Data invert control	Note 5-3
29	POL	I	Polarity selection	Note 5-4
30	DIO2	I/O	Horizontal Start Pulse Signal Input or Output	Note 5-1

## CN 2

Pin No.	Symbol	I/O	Function	Remark
1	VSS2	I	Ground	
2	V1	I	Gamma Voltage 1	Note 5-10
3	V2	I	Gamma Voltage 2	Note 5-10
4	V3	I	Gamma Voltage 3	Note 5-10
5	V4	I	Gamma Voltage 4	Note 5-10
6	V5	I	Gamma Voltage 5	Note 5-10
7	V6	I	Gamma Voltage 6	Note 5-10
8	V7	I	Gamma Voltage 7	Note 5-10
9	VSS2	I	Ground	
10	V8	I	Gamma Voltage 8	Note 5-10
11	V9	I	Gamma Voltage 9	Note 5-10
12	V10	I	Gamma Voltage 10	Note 5-10
13	V11	I	Gamma Voltage 11	Note 5-10
14	V12	I	Gamma Voltage 12	Note 5-10
15	V13	I	Gamma Voltage 13	Note 5-10
16	V14	I	Gamma Voltage 14	Note 5-10
17	VSS2	I	Ground	
18	VDD2	I	Voltage for analog circuit	Note 5-10
19	VCOM	I	Common Voltage	
20	XON	I	NC	
21	OE	I	Output Enable	Note 5-5
22	U/D	I	Up / Down Selection	Note 5-6
23	CKV	I	Vertical Shift Clock	Note 5-7
24	STVU	I/O	Vertical Shift Pulse Signal Input or Output	Note 5-6
25	STVD	I/O	Vertical Shift Pulse Signal Input or Output	Note 5-6
26	VGG	I	Gate On Voltage	Note 5-8
27	GND	I	Ground	
28	VCC	I	Voltage for logic circuit	
29	GND	I	Ground	
30	VEE	I	Gate Off Voltage	Note 5-9

Note 5-1: Select left or right shift

R/L	DIO1	DIO2	Shift
1	Input	Hi-Z	Left to right
0	Hi-Z	Input	Right to left

Note 5-2: Latch the polarity of outputs and switch the new data to outputs  
At the rising edge (CLK), latch the "POL" signal to control the polarity of the outputs.

Note 5-3: Control whether the Data R0~G5 are inverted or not. (PVI suggests connecting to GND)  
When "REV=1", these data will be inverted.  
EX: "00"→"3F", "07"→"38", "15"→"2A"

Note 5-4: Polarity selector for dot-inversion control. Available at the rising edge of LD.  
When POL=1: Even outputs range from V1~V7, and Odd outputs range from V8~V14;  
When POL=0: Even outputs range from V8~V14, and Odd outputs range from V1~V7.

Note 5-5: When OE is connected to high “1”, the driver outputs are disabled (Gate output =  $V_{EE}$ ). Under this condition, the operation of registers will not be affected.

Note 5-6: Select up or down shift

U/D	STVU	STVD	Shift
1	Hi-Z	Input	Down to Up
0	Input	Hi-Z	Up to Down

Note 5-7: Gate driver shift clock

Note 5-8: Gate on voltage,  $V_{GG}=20V$ .

Note 5-9: Gate off voltage,  $V_{EE}=-10V$ .

Note 5-10:

1) Relationship between input data and output voltage

The figure below shows the relationship between the input data and the output voltage with the polarity. The range of V1~V7 is for positive polarity, and V8~V14 for negative polarity. Please refer to the following pages to get the related resistor values and voltage calculation method.

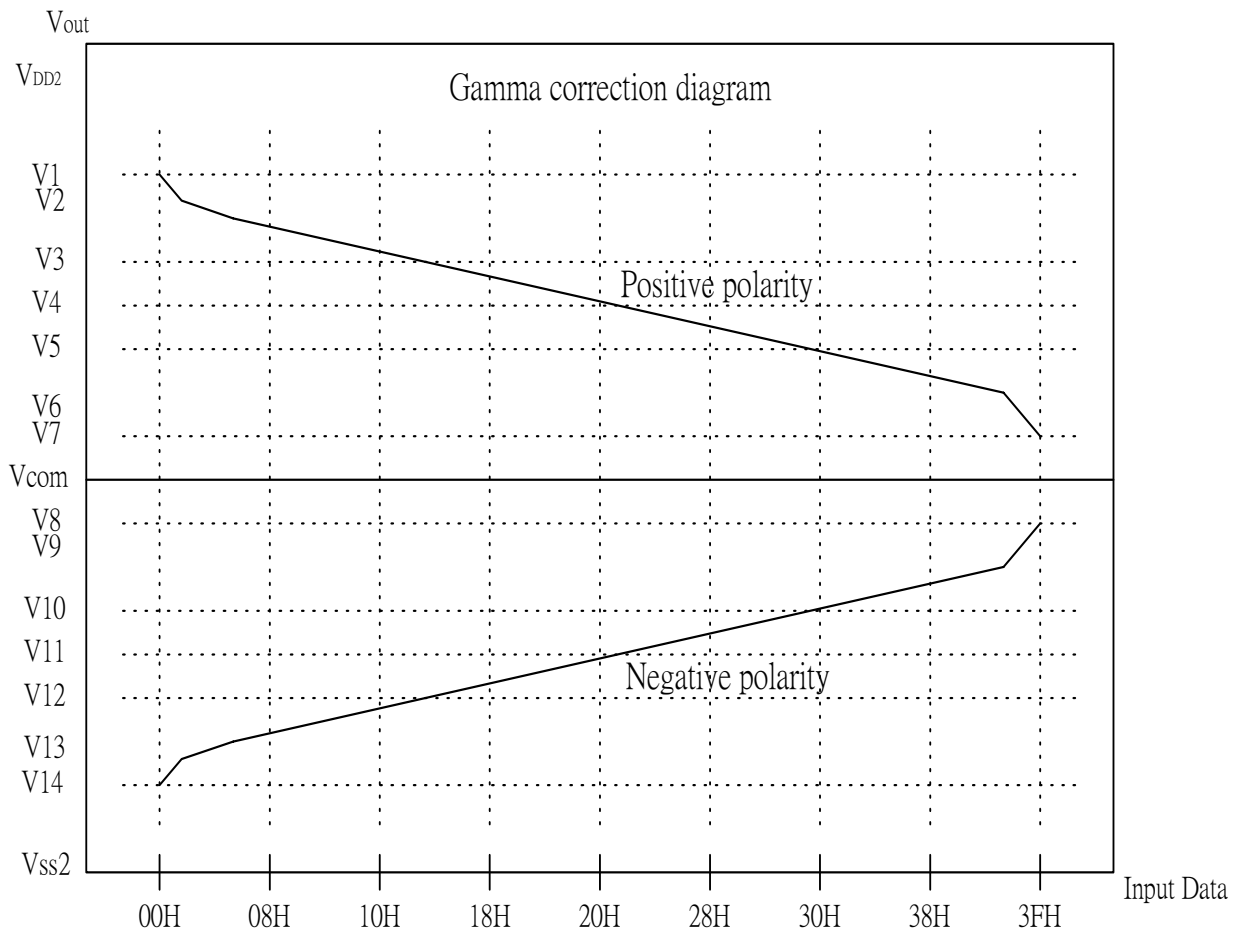

Remark:  $V_{DD2}-0.1 \geq V1 \geq V2 \geq V3 \geq V4 \geq V5 \geq V6 \geq V7$ ;  $V8 \geq V9 \geq V10 \geq V11 \geq V12 \geq V13 \geq V14 \geq V_{SS2}+0.1V$ .



## 2) Output voltage and input data

Output Voltage to Panel V.S. Input Data

<b>Data</b>	<b>Positive polarity Output Voltage</b>	<b>Negative polarity Output Voltage</b>
00H	V1	V14
01H	$V2=V3+(V1-V3) \times 58 / 64.4$	$V13=V14+(V12-V14) \times 6.4 / 64.4$
02H	$V3+(V1-V3) \times 52 / 64.4$	$V14+(V12-V14) \times 12.4 / 64.4$
03H	$V3+(V1-V3) \times 46.4 / 64.4$	$V14+(V12-V14) \times 18 / 64.4$
04H	$V3+(V1-V3) \times 41.2 / 64.4$	$V14+(V12-V14) \times 23.2 / 64.4$
05H	$V3+(V1-V3) \times 36.4 / 64.4$	$V14+(V12-V14) \times 28 / 64.4$
06H	$V3+(V1-V3) \times 32 / 64.4$	$V14+(V12-V14) \times 32.4 / 64.4$
07H	$V3+(V1-V3) \times 27.6 / 64.4$	$V14+(V12-V14) \times 36.8 / 64.4$
08H	$V3+(V1-V3) \times 23.6 / 64.4$	$V14+(V12-V14) \times 40.8 / 64.4$
09H	$V3+(V1-V3) \times 19.6 / 64.4$	$V14+(V12-V14) \times 44.8 / 64.4$
0AH	$V3+(V1-V3) \times 16.4 / 64.4$	$V14+(V12-V14) \times 48 / 64.4$
0BH	$V3+(V1-V3) \times 13.2 / 64.4$	$V14+(V12-V14) \times 51.2 / 64.4$
0CH	$V3+(V1-V3) \times 10.4 / 64.4$	$V14+(V12-V14) \times 54 / 64.4$
0DH	$V3+(V1-V3) \times 7.6 / 64.4$	$V14+(V12-V14) \times 56.8 / 64.4$
0EH	$V3+(V1-V3) \times 4.8 / 64.4$	$V14+(V12-V14) \times 59.6 / 64.4$
0FH	$V3+(V1-V3) \times 2.4 / 64.4$	$V14+(V12-V14) \times 62 / 64.4$
10H	V3	V12
11H	$V4+(V3-V4) \times 19.6 / 22$	$V12+(V11-V12) \times 2.4 / 22$
12H	$V4+(V3-V4) \times 17.6 / 22$	$V12+(V11-V12) \times 4.4 / 22$
13H	$V4+(V3-V4) \times 15.6 / 22$	$V12+(V11-V12) \times 6.4 / 22$
14H	$V4+(V3-V4) \times 13.6 / 22$	$V12+(V11-V12) \times 8.4 / 22$
15H	$V4+(V3-V4) \times 12 / 22$	$V12+(V11-V12) \times 10 / 22$
16H	$V4+(V3-V4) \times 10.4 / 22$	$V12+(V11-V12) \times 11.6 / 22$
17H	$V4+(V3-V4) \times 8.8 / 22$	$V12+(V11-V12) \times 13.2 / 22$
18H	$V4+(V3-V4) \times 7.6 / 22$	$V12+(V11-V12) \times 14.4 / 22$
19H	$V4+(V3-V4) \times 6.4 / 22$	$V12+(V11-V12) \times 15.6 / 22$
1AH	$V4+(V3-V4) \times 5.2 / 22$	$V12+(V11-V12) \times 16.8 / 22$
1BH	$V4+(V3-V4) \times 4 / 22$	$V12+(V11-V12) \times 18 / 22$
1CH	$V4+(V3-V4) \times 3.2 / 22$	$V12+(V11-V12) \times 18.8 / 22$
1DH	$V4+(V3-V4) \times 2.4 / 22$	$V12+(V11-V12) \times 19.6 / 22$
1EH	$V4+(V3-V4) \times 1.6 / 22$	$V12+(V11-V12) \times 20.4 / 22$
1FH	$V4+(V3-V4) \times 0.8 / 22$	$V12+(V11-V12) \times 21.2 / 22$

Output Voltage to Panel V.S. Input Data (continued)

<b>Data</b>	<b>Positive polarity Output Voltage</b>	<b>Negative polarity Output Voltage</b>
20H	V4	V11
21H	$V5+(V4-V5) \times 12 / 12.8$	$V11+(V10-V11) \times 0.8 / 12.8$
22H	$V5+(V4-V5) \times 11.2 / 12.8$	$V11+(V10-V11) \times 1.6 / 12.8$
23H	$V5+(V4-V5) \times 10.4 / 12.8$	$V11+(V10-V11) \times 2.4 / 12.8$
24H	$V5+(V4-V5) \times 9.6 / 12.8$	$V11+(V10-V11) \times 3.2 / 12.8$
25H	$V5+(V4-V5) \times 8.8 / 12.8$	$V11+(V10-V11) \times 4 / 12.8$
26H	$V5+(V4-V5) \times 8 / 12.8$	$V11+(V10-V11) \times 4.8 / 12.8$
27H	$V5+(V4-V5) \times 7.2 / 12.8$	$V11+(V10-V11) \times 5.6 / 12.8$
28H	$V5+(V4-V5) \times 6.4 / 12.8$	$V11+(V10-V11) \times 6.4 / 12.8$
29H	$V5+(V4-V5) \times 5.6 / 12.8$	$V11+(V10-V11) \times 7.2 / 12.8$
2AH	$V5+(V4-V5) \times 4.8 / 12.8$	$V11+(V10-V11) \times 8 / 12.8$
2BH	$V5+(V4-V5) \times 4 / 12.8$	$V11+(V10-V11) \times 8.8 / 12.8$
2CH	$V5+(V4-V5) \times 3.2 / 12.8$	$V11+(V10-V11) \times 9.6 / 12.8$
2DH	$V5+(V4-V5) \times 2.4 / 12.8$	$V11+(V10-V11) \times 10.4 / 12.8$
2EH	$V5+(V4-V5) \times 1.6 / 12.8$	$V11+(V10-V11) \times 11.2 / 12.8$
2FH	$V5+(V4-V5) \times 0.8 / 12.8$	$V11+(V10-V11) \times 12 / 12.8$
30H	V5	V10
31H	$V7+(V5-V7) \times 26.8 / 27.6$	$V10+(V8-V10) \times 0.8 / 27.6$
32H	$V7+(V5-V7) \times 26 / 27.6$	$V10+(V8-V10) \times 1.6 / 27.6$
33H	$V7+(V5-V7) \times 25.2 / 27.6$	$V10+(V8-V10) \times 2.4 / 27.6$
34H	$V7+(V5-V7) \times 24.4 / 27.6$	$V10+(V8-V10) \times 3.2 / 27.6$
35H	$V7+(V5-V7) \times 23.6 / 27.6$	$V10+(V8-V10) \times 4 / 27.6$
36H	$V7+(V5-V7) \times 22.4 / 27.6$	$V10+(V8-V10) \times 5.2 / 27.6$
37H	$V7+(V5-V7) \times 21.2 / 27.6$	$V10+(V8-V10) \times 6.4 / 27.6$
38H	$V7+(V5-V7) \times 20 / 27.6$	$V10+(V8-V10) \times 7.6 / 27.6$
39H	$V7+(V5-V7) \times 18.4 / 27.6$	$V10+(V8-V10) \times 9.2 / 27.6$
3AH	$V7+(V5-V7) \times 16.8 / 27.6$	$V10+(V8-V10) \times 10.8 / 27.6$
3BH	$V7+(V5-V7) \times 14.8 / 27.6$	$V10+(V8-V10) \times 12.8 / 27.6$
3CH	$V7+(V5-V7) \times 12.8 / 27.6$	$V10+(V8-V10) \times 14.8 / 27.6$
3DH	$V7+(V5-V7) \times 10.4 / 27.6$	$V10+(V8-V10) \times 17.2 / 27.6$
3EH	$V7+(V5-V7) \times 6.4 / 27.6$	$V10+(V8-V10) \times 21.2 / 27.6$
3FH	V7	V8

3) Typical Application Circuit (When V<sub>DD2</sub> = +9.5V)

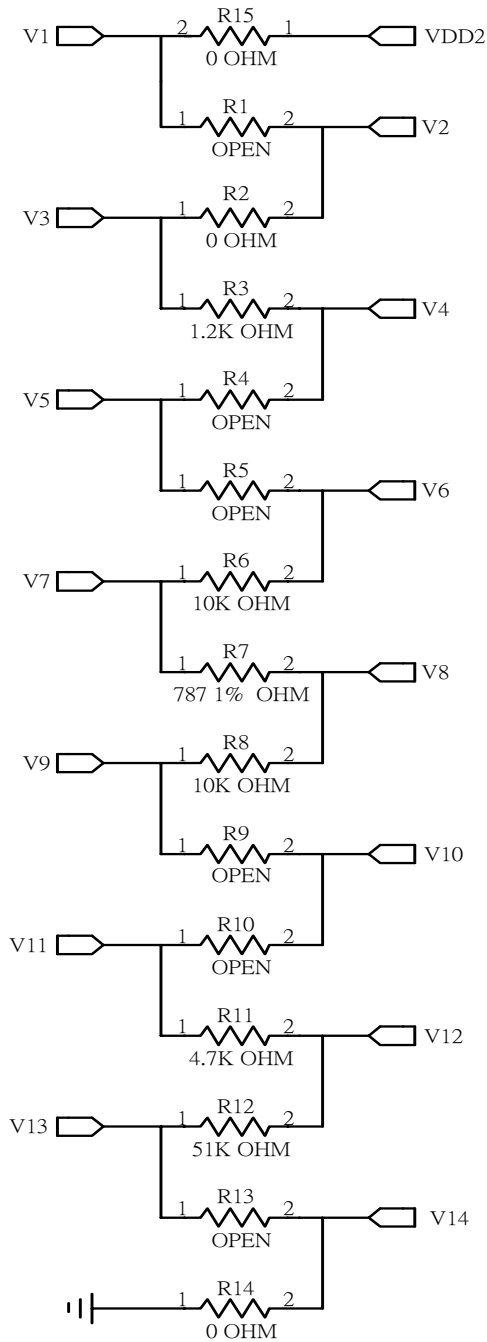

**5-2) Backlight driving**

Connector type: JST BHSR-02VS-1, PIN No 2 pins, pitch=3.5mm

Pin No	Symbol	Description	Remark
1	VL1	Input terminal (Hi voltage side)	Wire color : Pink
2	VL2	Input terminal (Low voltage side)	Wire color : White Note 5-11

Note 5-11: Low voltage side of backlight inverter connects with ground of inverter circuits.

**6. Absolute Maximum Ratings:**

$V_{SS1}=V_{SS2}=GND=0V, T_a=25^{\circ}C$

Parameters	Symbol	MIN.	MAX.	Unit	Remark
Supply Voltage	$V_{DD1}$	-0.3	5.0	V	
	$V_{CC}$			V	
	$V_{DD2}$	-0.5	12.0	V	
	$V_{GG}$	-0.3	40.0	V	
	$V_{GG}-V_{EE}$	-	40	V	
	$V_{EE}$	-20	0.3	V	
Digital Input	$V_{IN}$	-0.5	$V_{CC}+0.5$	V	
Backlight Driving Voltage	$V_L$	-	2000	V	
Backlight Driving Frequency	$F_L$	0	100	KHz	
Storage Temperature	$T_{ST}$	-30	80	$^{\circ}C$	
Operating Temperature	$T_{OP}$	-20	80	$^{\circ}C$	

**7. Electrical Characteristics**
**7-1) Recommended Operating Conditions:**

$V_{SS1}=V_{SS2}=GND=0V, T_a=25^{\circ}C$

Item	Symbol	Min.	Typ.	Max.	Unit	Remark
Supply Voltage for Source Driver	$V_{DD1}$	3.0	3.3	3.6	V	
	$V_{DD2}$	9	9.5	10	V	
Supply Voltage for Gate Driver	$V_{GG}$	-	20	-	V	
	$V_{EE}$	-	-10	-	V	
	$V_{CC}$	3.0	3.3	3.6	V	
Digital Input Voltage	$V_{IH}$	$0.8V_{DD1}$	-	$V_{DD1}$	V	
	$V_{IL}$	0	-	$0.2V_{DD1}$	V	

**7-2) Recommended Driving Condition for Back Light**

$T_a=25^{\circ}C$

Parameter	Symbol	Min.	Typ.	Max.	Unit	Remark
Lamp Voltage	$V_L$	TBD	TBD	TBD	V	$I_L=6mA$
Lamp Current	$I_L$	TBD	TBD	TBD	mA	Note 7-1
Lamp Frequency	$P_L$	TBD	TBD	TBD	KHz	Note 7-2
Starting Voltage (25 $^{\circ}C$ ) (Reference Value)	$V_s$	-	-	TBD	Vrms	Note 7-3
Starting Voltage (0 $^{\circ}C$ ) (Reference Value)	$V_s$	-	-	TBD	Vrms	Note 7-3

Note 7-1: In order to have proper operation of the B/L, no matter what kind of inverters, the output lamp current must be between Min. and Max. values to avoid the abnormal display image caused by B/L.

Note 7-2: The waveform of lamp driving voltage should be as close to a perfect sine wave as possible.

Note 7-3: This value is not the output voltage of inverter.  
The voltage of inverter must be larger than the starting voltage.

**7-3) Power Consumption**

Parameter	Symbol	Min.	Typ.	Max.	Unit	Remark
Supply Current for Gate Driver (Hi level)	$I_{GG}$	$V_{GH}=+20V$	TBD	TBD	mA	
Supply Current for Gate Driver (Low level)	$I_{EE}$	$V_{EE}=-10V$	TBD	TBD	mA	
Supply Current for Source Driver (Digital)	$I_{DD1}$	$V_{DD1}=+3.3V$	TBD	TBD	mA	
Supply Current for Source Driver (Analog)	$I_{DD2}$	$V_{DD2}=+9.5V$	TBD	TBD	mA	
Supply Current for Gate Driver (Digital)	$I_{CC}$	$V_{CC}=+3.3V$	TBD	TBD	mA	
LCD Panel Power Consumption			TBD	TBD	mW	Note 7-4
Back Light Lamp Power Consumption			TBD	TBD	W	Note 7-5

Note 7-4: The power consumption for back light is not included.

Note 7-5: Back light lamp power consumption is calculated by  $I_L \times V_L$ .

**8. Pixel Arrangement**

The LCD module pixel arrangement is stripe configuration.

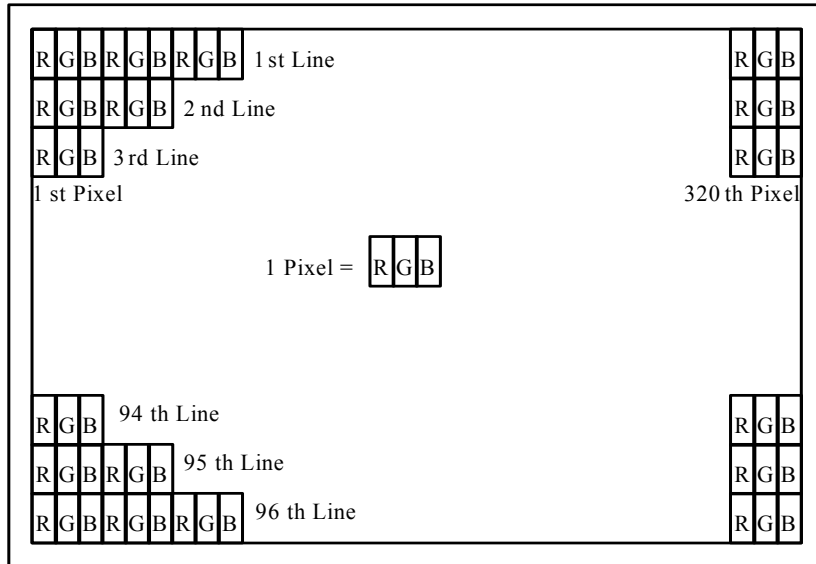

## 9. Display Color and Gray Scale Reference

Color		Input Color Data																	
		Red						Green						Blue					
		R5	R4	R3	R2	R1	R0	G5	G4	G3	G2	G1	G0	B5	B4	B3	B2	B1	B0
Basic Colors	Black	0	0	0	0	0	0	0	0	0	0	0	0	0	0	0	0	0	0
	Red (63)	1	1	1	1	1	1	0	0	0	0	0	0	0	0	0	0	0	0
	Green (63)	0	0	0	0	0	0	1	1	1	1	1	1	0	0	0	0	0	0
	Blue (63)	0	0	0	0	0	0	0	0	0	0	0	0	1	1	1	1	1	1
	Cyan	0	0	0	0	0	0	1	1	1	1	1	1	1	1	1	1	1	1
	Magenta	1	1	1	1	1	1	0	0	0	0	0	0	1	1	1	1	1	1
	Yellow	1	1	1	1	1	1	1	1	1	1	1	1	0	0	0	0	0	0
	White	1	1	1	1	1	1	1	1	1	1	1	1	1	1	1	1	1	1
Red	Red (00)	0	0	0	0	0	0	0	0	0	0	0	0	0	0	0	0	0	0
	Red (01)	0	0	0	0	0	1	0	0	0	0	0	0	0	0	0	0	0	0
	Red (02)	0	0	0	0	1	0	0	0	0	0	0	0	0	0	0	0	0	0
	Darker																		
	↓	↓	↓	↓	↓	↓	↓	↓	↓	↓	↓	↓	↓	↓	↓	↓	↓	↓	↓
	Brighter																		
	Red (61)	1	1	1	1	0	1	0	0	0	0	0	0	0	0	0	0	0	0
	Red (62)	1	1	1	1	1	0	0	0	0	0	0	0	0	0	0	0	0	0
Red (63)	1	1	1	1	1	1	0	0	0	0	0	0	0	0	0	0	0	0	
Green	Green (00)	0	0	0	0	0	0	0	0	0	0	0	0	0	0	0	0	0	0
	Green (01)	0	0	0	0	0	0	0	0	0	0	0	1	0	0	0	0	0	0
	Green (02)	0	0	0	0	0	0	0	0	0	0	1	0	0	0	0	0	0	0
	Darker																		
	↓	↓	↓	↓	↓	↓	↓	↓	↓	↓	↓	↓	↓	↓	↓	↓	↓	↓	↓
	Brighter																		
	Green (61)	0	0	0	0	0	0	1	1	1	1	0	1	0	0	0	0	0	0
	Green (62)	0	0	0	0	0	0	1	1	1	1	1	0	0	0	0	0	0	0
Green (63)	0	0	0	0	0	0	1	1	1	1	1	1	0	0	0	0	0	0	
Blue	Blue (00)	0	0	0	0	0	0	0	0	0	0	0	0	0	0	0	0	0	0
	Blue (01)	0	0	0	0	0	0	0	0	0	0	0	0	0	0	0	0	0	1
	Blue (02)	0	0	0	0	0	0	0	0	0	0	0	0	0	0	0	0	1	0
	Darker																		
	↓	↓	↓	↓	↓	↓	↓	↓	↓	↓	↓	↓	↓	↓	↓	↓	↓	↓	↓
	Brighter																		
	Blue (61)	0	0	0	0	0	0	0	0	0	0	0	0	1	1	1	1	0	1
	Blue (62)	0	0	0	0	0	0	0	0	0	0	0	0	1	1	1	1	1	0
Blue (63)	0	0	0	0	0	0	0	0	0	0	0	0	1	1	1	1	1	1	

**10. Block Diagram**

**10-1) TFT-module Block Diagram**

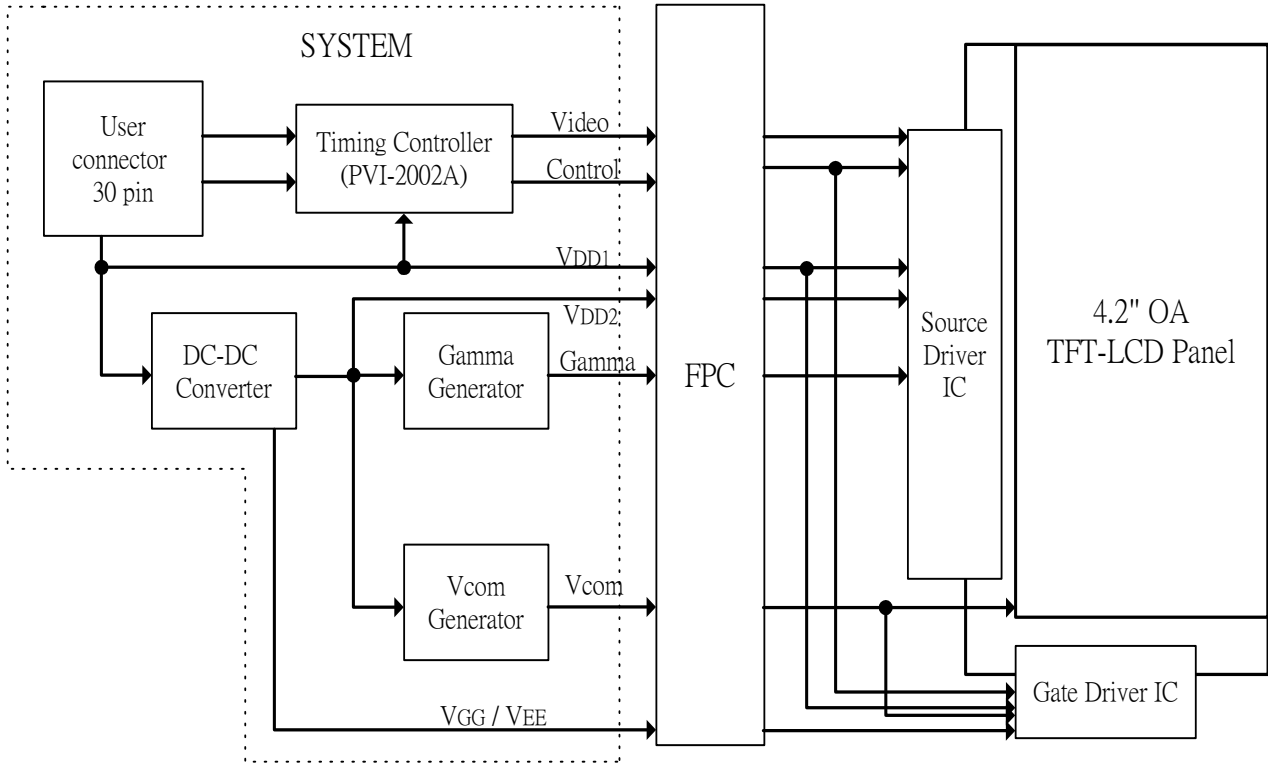

If you use PD042OX1, you can apply PVI-2002A(Timing controller) which will generate timing signals to support PD042OX1.

## 11. Interface Timing

### 11.1) Timing Parameters

AC Electrical Characteristics ( $V_{CC}=V_{DD1}=3.3V$ ,  $V_{DD2}=9.5V$ ,  $GND=V_{SS1}=V_{SS2}=0V$ ,  $T_a=25^{\circ}C$ )

Parameter	Symbol	Min.	Typ.	Max.	Unit
CLK Frequency	Fclk	-	2.5	-	MHz
CLV1 Period	Tcph	-	0.4	-	us
CLK Pulse Width	Tcw	8	-	-	ns
Data Set-up Time	Tsu	4	-	-	ns
Data Hold Time	Thd	2	-	-	ns
Propagation Delay of DIO2/1	Tphl	6	10	15	ns
Time That The Last Data to LD	Tld	1	-	-	Tcph
Pulse width of LD	Twld	2	-	-	Tcph
Time That LD to DIO1/2	Tlds	5	-	-	Tcph
POL Set-up Time	Tpsu	6	-	-	ns
POL Hold Time	Tphd	6	-	-	ns
OE Pulse Width	T <sub>OEV</sub>	1	-	-	μs
CKV Pulse Width	T <sub>CKV</sub>	2.5	-	-	μs
STV Set-up Time	T <sub>SUV</sub>	700	-	-	ns
STV Hold Time	T <sub>HDV</sub>	700	-	-	ns
Horizontal Display Period	T <sub>HDP</sub>	-	320	-	Tcph
Horizontal Period Timing Range	T <sub>HP</sub>	-	400	-	Tcph
Horizontal Lines Per Field	T <sub>V</sub>	100	104	130	T <sub>HP</sub>
Vertical Display Timing Range	T <sub>DV</sub>	-	96	-	T <sub>HP</sub>



11.2) Timing Diagram

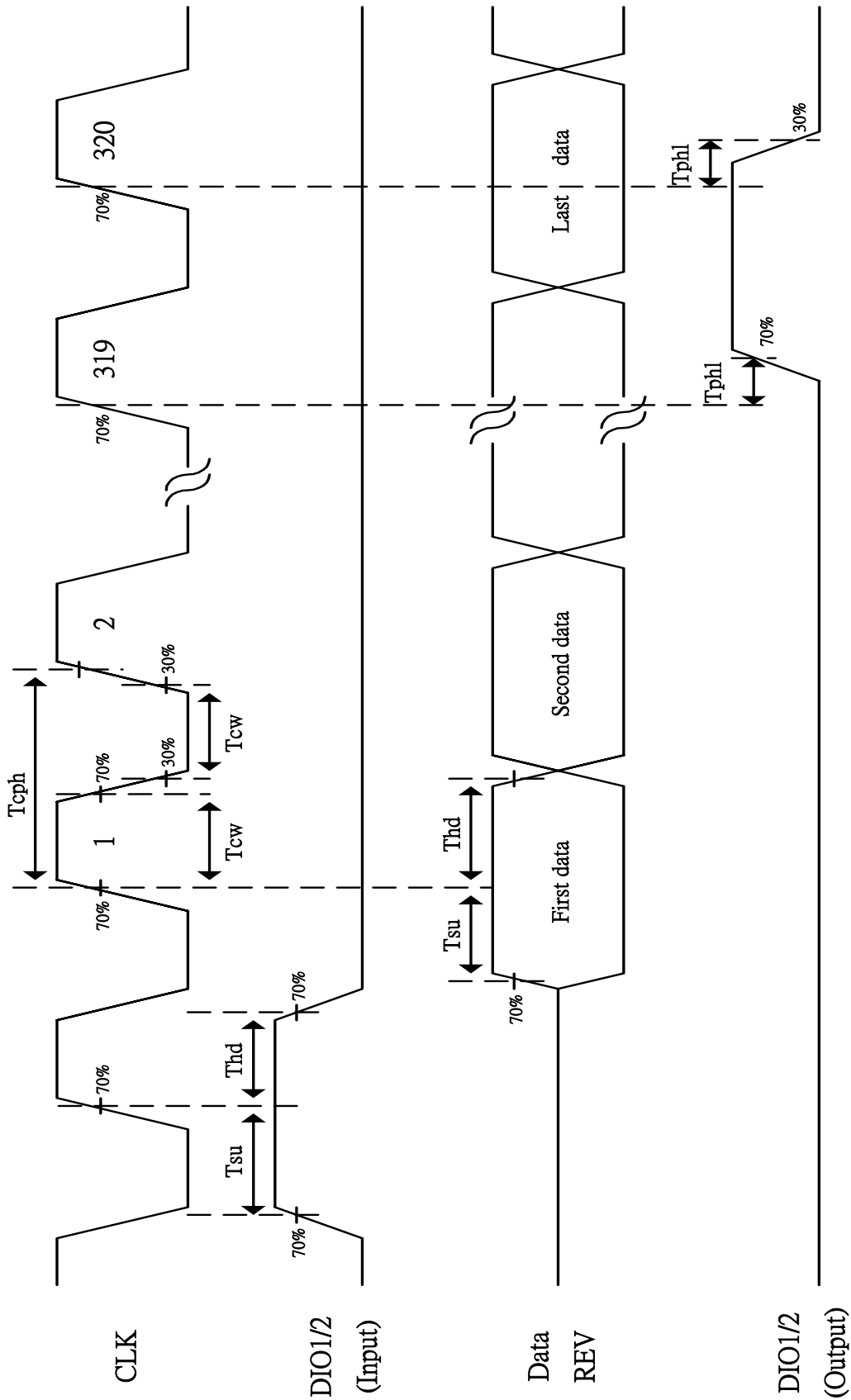

Fig. 11-1 Operation Mode

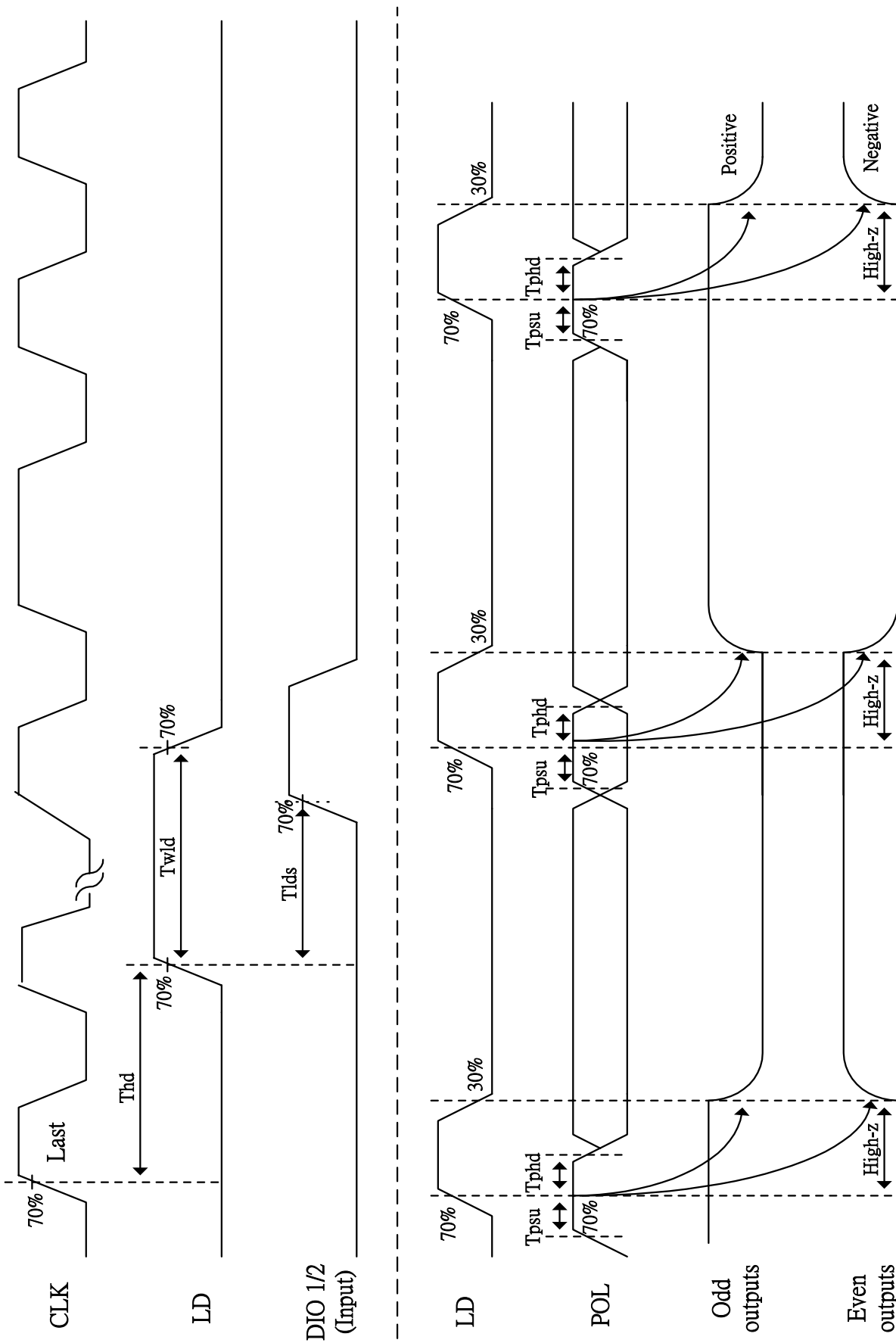

Fig. 11-2 Horizontal timing

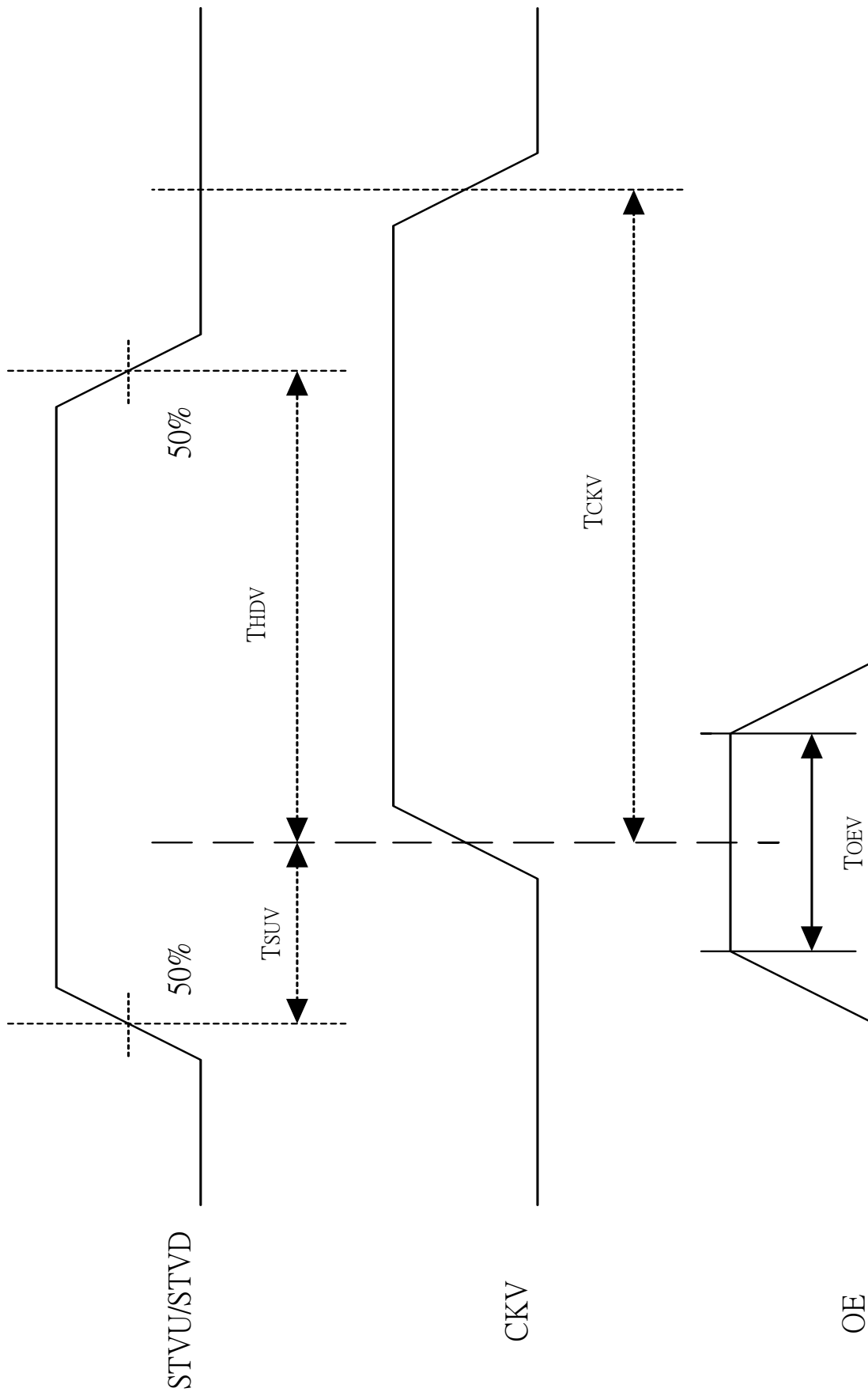

Fig. 11-3 Vertical shift clock timing

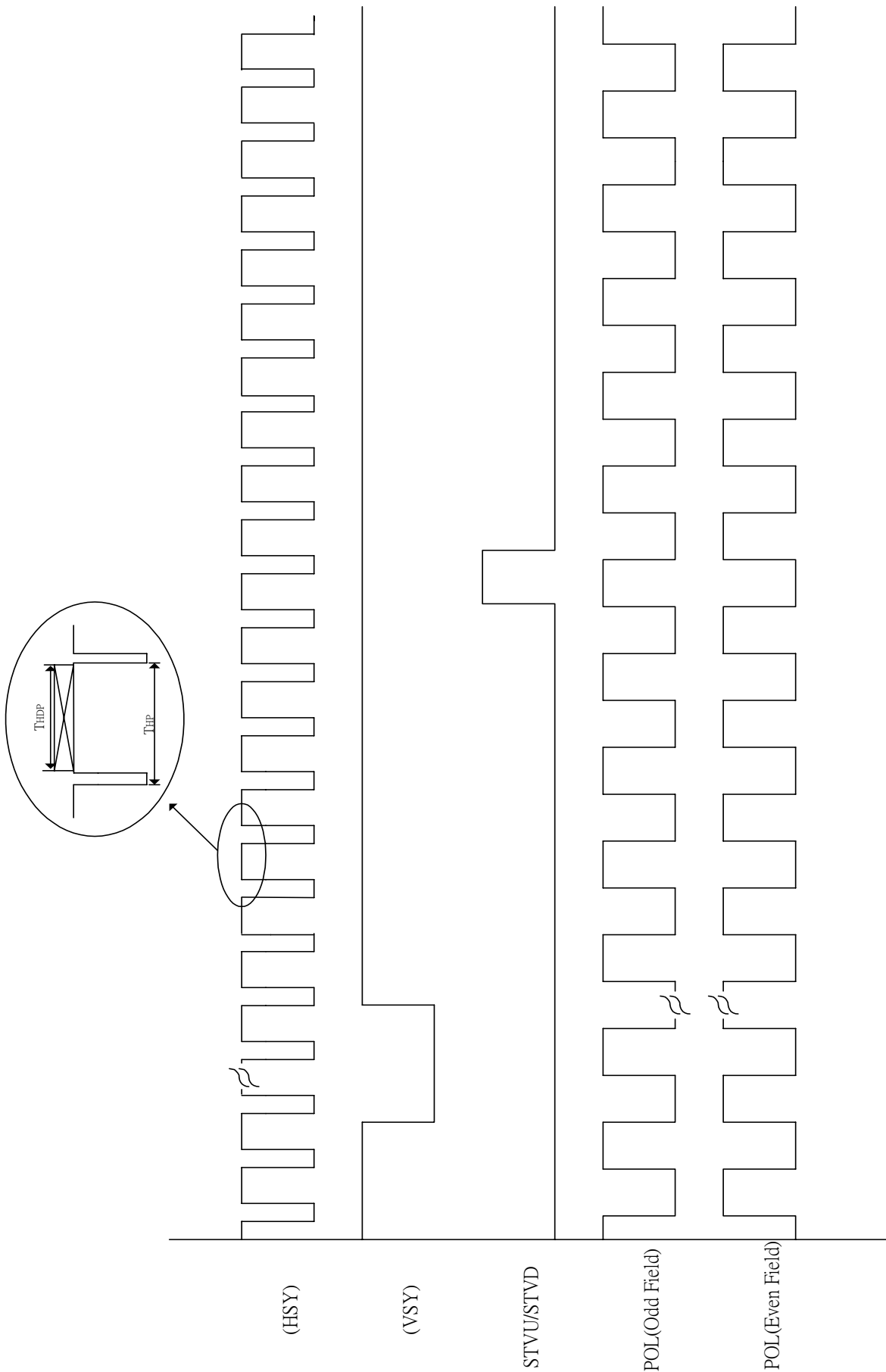
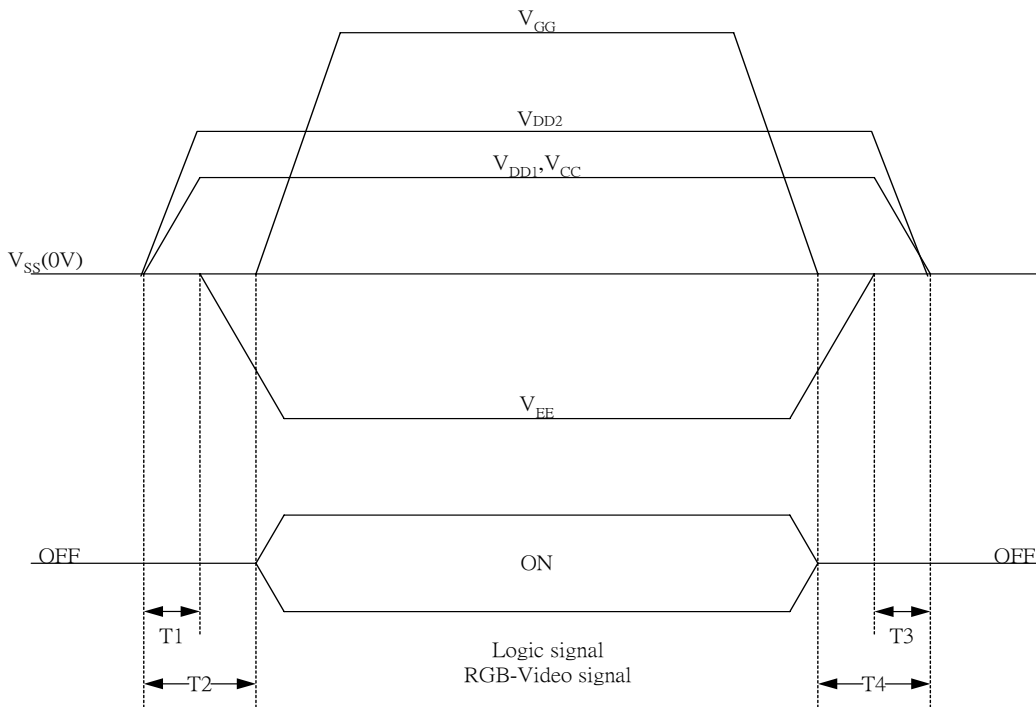

Fig. 11-4 Vertical timing

**12. Power On Sequence**



1.  $10\text{ms} \leq T1 < T2$
2.  $0\text{ms} < T3 \leq T4 \leq 10\text{ms}$

**13. Optical Characteristics**

**13-1) Specification:**

Ta=25°C

Parameter	Symbol	Condition	MIN.	TYP.	MAX.	Unit	Remarks
Viewing Angle	Horizontal	$\theta$	TBD	TBD	-	deg	Note 13-1
	Vertical	$\theta$ (to 12 o'clock)	TBD	TBD	-	deg	
		$\theta$ (to 6 o'clock)	TBD	TBD	-	deg	
Contrast Ratio	CR	At optimized viewing angle	200	400	-	-	Note 13-2
Response time	Rise	Tr	-	15	30	ms	Note 13-3
	Fall	Tf	-	25	50	ms	
Brightness		$\theta=0^\circ/\varphi=0$	TBD	TBD	-	cd/m <sup>2</sup>	Note 13-4
Luminance Uniformity	U		TBD	TBD	-	%	Note 13-5
White Chromaticity	x		TBD	TBD	TBD	-	
	y		TBD	TBD	TBD	-	
Cross Talk		$\theta=0^\circ$	-	-	3.5	%	Note 13-6

Note 13-1: The definitions of viewing angles are as follow

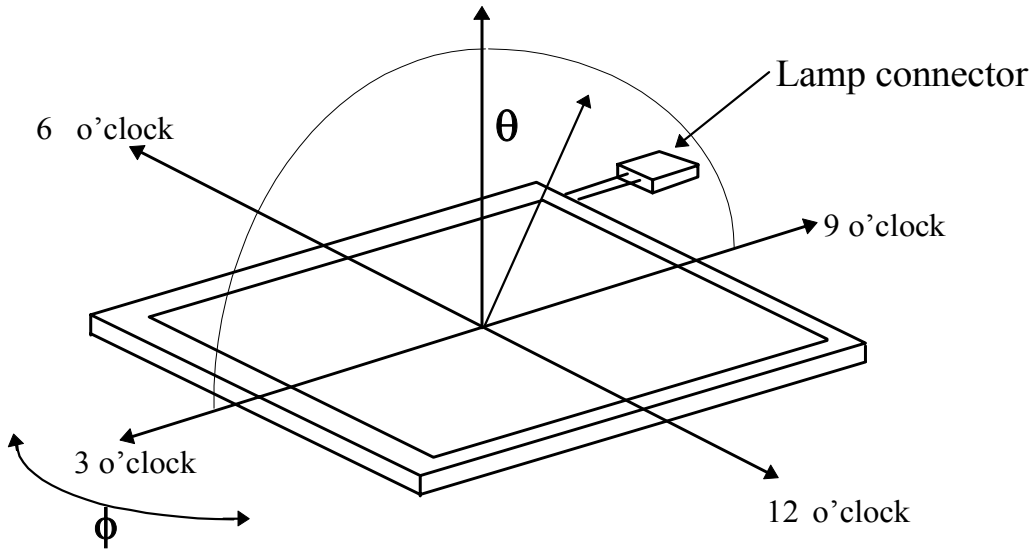

Note 13-2: The definition of contrast ratio  $CR = \frac{\text{Luminance at gray level 63}}{\text{Luminance at gray level 0}}$

Note 13-3: Definition of Response Time  $T_r$  and  $T_f$ :

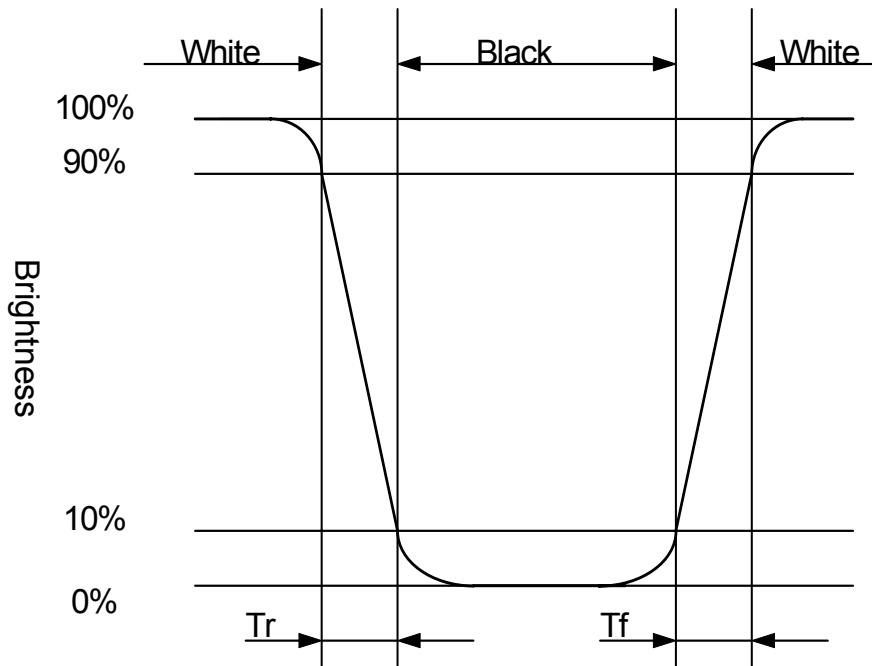

Note 13-4: All optical measurements shall be performed after backlight being turned-on for 30 mins. The optical characteristics shall be measured in dark room (ambient illumination on panel surface less than 1 Lux). The measuring configuration shows as following figure.

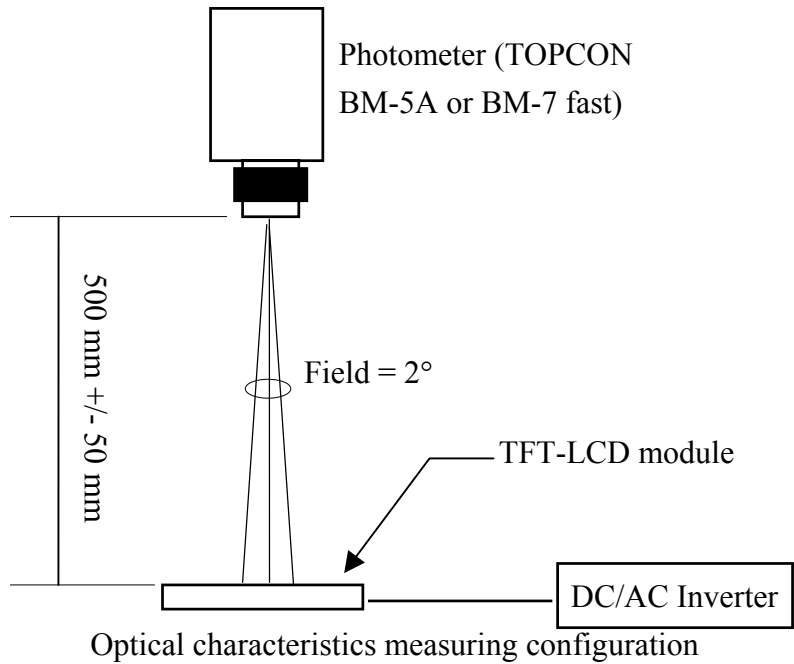

Note 13-5: The uniformity of LCD is defined as

$$U = \frac{\text{The Minimum Brightness of the 9 testing Points}}{\text{The Maximum Brightness of the 9 testing Points}}$$

Luminance meter: BM-5A or BM-7 fast (TOPCON)

Measurement distance: 500 mm +/- 50 mm

Ambient illumination: < 1 Lux

Measuring direction: Perpendicular to the surface of module

The test pattern is white (Gray Level 63).

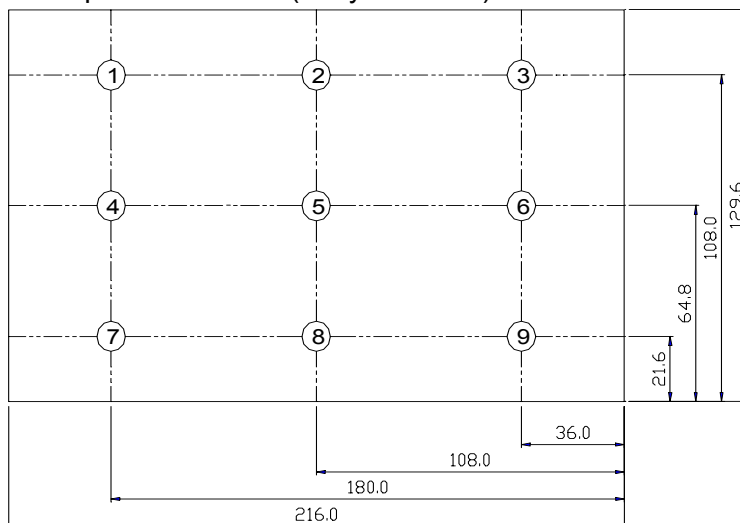

Note 13-6: Cross Talk (CTK) =  $\frac{|YA-YB|}{YA} \times 100\%$

YA: Brightness of Pattern A

YB: Brightness of Pattern B

Luminance meter: BM-5A or BM-7 fast (TOPCON)

Measurement distance: 500 mm +/- 50 mm

Ambient illumination: < 1 Lux

Measuring direction: Perpendicular to the surface of module

Pattern A  
(Gray Level 31)

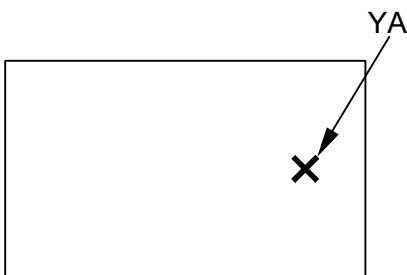

Pattern B  
(Gray Level 31, except the black box in the center )

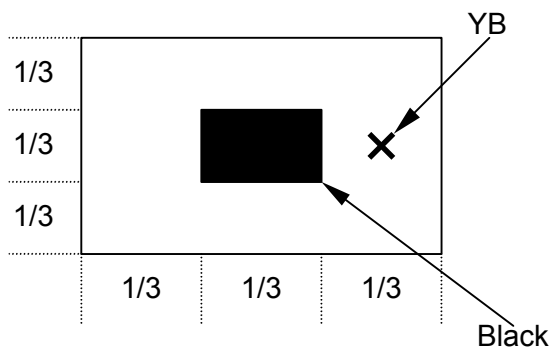

**X**: Measuring Point (A and B are at the same point.)

Black (Gray Level 0)

Note 13-7: Topcon BM-5A or BM-7 fast luminance meter 2° field of view is used in the testing (after 30 minutes' B/L power-on). The typical luminance value is measured at lamp current **TBD** mA.



**14. Handling Cautions****14-1) Mounting of module**

- a) Please power off the module when you connect the input/output connector.
- b) Please connect the ground pattern of the inverter circuit surely. If the connection is not perfect, some following problems may happen possibly.
  - 1.The noise from the backlight unit will increase.
  - 2.The output from inverter circuit will be unstable.
  - 3.In some cases a part of module will heat.
- c) Polarizer which is made of soft material and susceptible to flaw must be handled carefully.
- d) Protective film (Laminator) is applied on surface to protect it against scratches and dirt. It is recommended to peel off the laminator before use and taking care of static electricity.

**14-2) Precautions in mounting**

- a) When metal part of the TFT-LCD module (shielding lid and rear case) is soiled, wipe it with soft dry cloth.
- b) Wipe off water drops or finger grease immediately. Long contact with water may cause discoloration or spots.
- c) TFT-LCD module uses glass which breaks or cracks easily if dropped or bumped on hard surface. Please handle with care.
- d) Since CMOS LSI is used in the module. So take care of static electricity and earth yourself when handling.

**14-3) Adjusting module**

- a) Adjusting volumes on the rear face of the module have been set optimally before shipment.
- b) Therefore, do not change any adjusted values. If adjusted values are changed, the specifications described may not be satisfied.

**14-4) Others**

- a) Do not expose the module to direct sunlight or intensive ultraviolet rays for many hours.
- b) Store the module at a room temperature place.
- c) The voltage of beginning electric discharge may over the normal voltage because of leakage current from approach conductor by to draw lump read lead line around.
- d) If LCD panel breaks, it is possibly that the liquid crystal escapes from the panel. Avoid putting it into eyes or mouth. When liquid crystal sticks on hands, clothes or feet. Wash it out immediately with soap.
- e) Observe all other precautionary requirements in handling general electronic components.
- f) Please adjust the voltage of common electrode as material of attachment by 1 module.

**14-5) Polarizer mark**

The polarizer mark is to describe the direction of wide view angle film how to match up with the rubbing direction.

## 15. Reliability Test

No	Test Item	Test Condition	Remark
1	High Temperature Storage Test	Ta = +80°C, 240 hrs	
2	Low Temperature Storage Test	Ta = -30°C, 240 hrs	
3	High Temperature Operation Test	Ta = +80°C, 240 hrs	
4	Low Temperature Operation Test	Ta = -20°C, 240 hrs	
5	High Temperature & High Humidity Operation Test	Ta = +60°C, 90%RH, 240 hrs (No Condensation)	
6	Thermal Cycling Test (non-operating)	0°C → +60°C, 50 Cycles 1Hr 1Hr	
7	Vibration Test (non-operating)	Frequency : 10 ~ 55 Hz, Amplitude : 1.5 mm 58~500Hz, 1G Sweep time: 11 min Test Period: 6 Cycles for each direction of X, Y, Z	
8	Shock Test (non-operating)	100G, 6ms, X,Y, Z 3 times for each direction	
9	Electrostatic Discharge Test (non-operating)	200pF, 0Ω ±200V 1 time / each terminal	

Ta: ambient temperature

[Judgement Criteria]

Under the display quality test conditions with normal operation state, there should be no change which may affect practical display function.

## 16. Indication of Lot Number Label

Indicated contents of the label

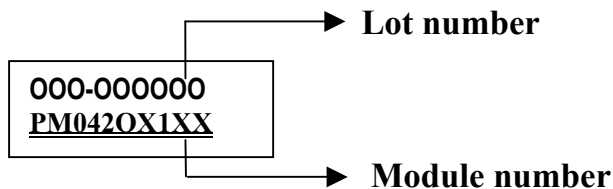

Contents of lot number : 1<sup>st</sup>~3<sup>rd</sup>—The OEM product

5<sup>th</sup>—Production year : 1999⇒9, 2000⇒A, 2001⇒B.....

6<sup>th</sup>—Production month : 1, 2, 3,....9, A, B, C

7<sup>th</sup>~8<sup>th</sup>—Production size : 4.2" ⇒42

9<sup>th</sup>~10<sup>th</sup>— Serial numbers : 01~99

**17. Packing Diagram**

TBD

---

**Revision History**

<b>Rev.</b>	<b>Issued Date</b>	<b>Revised</b>	<b>Contents</b>
0.1	Oct. 08,2004	New	