

Version :5.0



Inselkammerstr. 10
82008 Unterhaching
Tel: +49 89 614 503 40
www.hy-line.de/computer

TECHNICAL SPECIFICATION
MODEL NO. : PM070WT3

The content of this information is subject to be changed without notice.
Please contact PVI or its agent for further information.

Customer's Confirmation

Customer _____

Date _____

By _____

PVI's Confirmation

Confirmed By _____

Prepared By _____

Revision History

Rev.	Issued Date	Revised Contents	Remark
0.1	Oct.24.2006	New	
0.2	Nov.20.2006	1.Modify page 17 LED life time remark From 6mA modify to 20mA 2.modify LED voltage to 11.0V(typ),11.5V(max)	
0.3	Nov.21.2006	modify LED Lifetime (Add remark)	
1.0	Dec.25,2006	Release version	
2.0	Apr.17,2007	Modify Block Diagram	
3.0	Oct.15,2007	Page 11 8.Electrical Characteristics 8-3) Recommended Driving Condition for LED Back Light Modify Supply voltage of LED backlight Modify Note 8-4 Back-light Diagram Page 22 15. Handling Cautions Delete 15-1) Mounting of module b) description Page 23 16. Reliability Test Modify Low Temperature Storage Test From -30°C promote to -40°C	
4.0	Mar. 24,2008	Page 9 Modify Note 6-1 Page 10 Add 6.4) Integration Design Guide	
5.0	March.24.2008	Add Page 23 15.Handling Cautions 15-1 item e)	

TECHNICAL SPECIFICATION

CONTENTS

NO.	ITEM	PAGE
-	Cover	1
-	Revision History	2
-	Contents	3
1	Application	4
2	Features	4
3	Mechanical Specifications	4
4	Mechanical Drawing of TFT-LCD module	5
5	Input / Output Terminals	7
6	Touch Panel Characteristics	9
7	Absolute Maximum Ratings	11
8	Electrical Characteristics	11
9	Pixel Arrangement	13
10	Display Color and Gray Scale Reference	14
11	Block Diagram	15
12	Interface Timing	16
13	Power On Sequence	19
14	Optical Characteristics	19
15	Handling Cautions	23
16	Reliability Test	25
17	Packing Diagram	26

1. Application

This data sheet applies to a color TFT LCD module, PM070WT3.
The application of panel are OA product, portable DVD, car TV(must use Analog to Digital driving board), which requires high quality flat panel display.

Prime View assume no responsibility for any damage resulting from the use of the device which dose not comply with the instructions and the precautions in these specification sheet.

2. Features

- . Wide VGA (800*480 pixels) resolution
- . Amorphous silicon TFT LCD panel with LED back-light unit
- . Pixel in stripe configuration
- . Thin and light weight
- . Display Colors : 262,144 colors
- . +3.3V DC supply voltage for TFT LCD panel driving
- . Wide viewing angle
- . TTL interface
- . Module with resistive type touch panel .

3. Mechanical Specifications

Parameter	Specifications	Unit
Screen Size	7.0(diagonal)	inch
Display Format	800×(R, G, B)×480	dot
Display Colors	262,144	
Active Area	152.4(H)×91.44(V)	mm
Pixel Pitch	0.1905(H)×0.1905(V)	mm
Pixel Configuration	Stripe	
Outline Dimension	166.3(W)×105.3 (H)×12.45 (typ.) (D)	mm
Weight	318±15	g
Back-light	33-LED	
Surface treatment	Anti-glare and Wide View Film	
Display mode	Normally white	
Surface treatment of Touch Panel	3H	
Gray scale inversion direction	6 o'clock [ref to Note 14-1]	

4.Mechanical Drawing of TFT-LCD Module
Outline Drawing : Front View (unit mm)

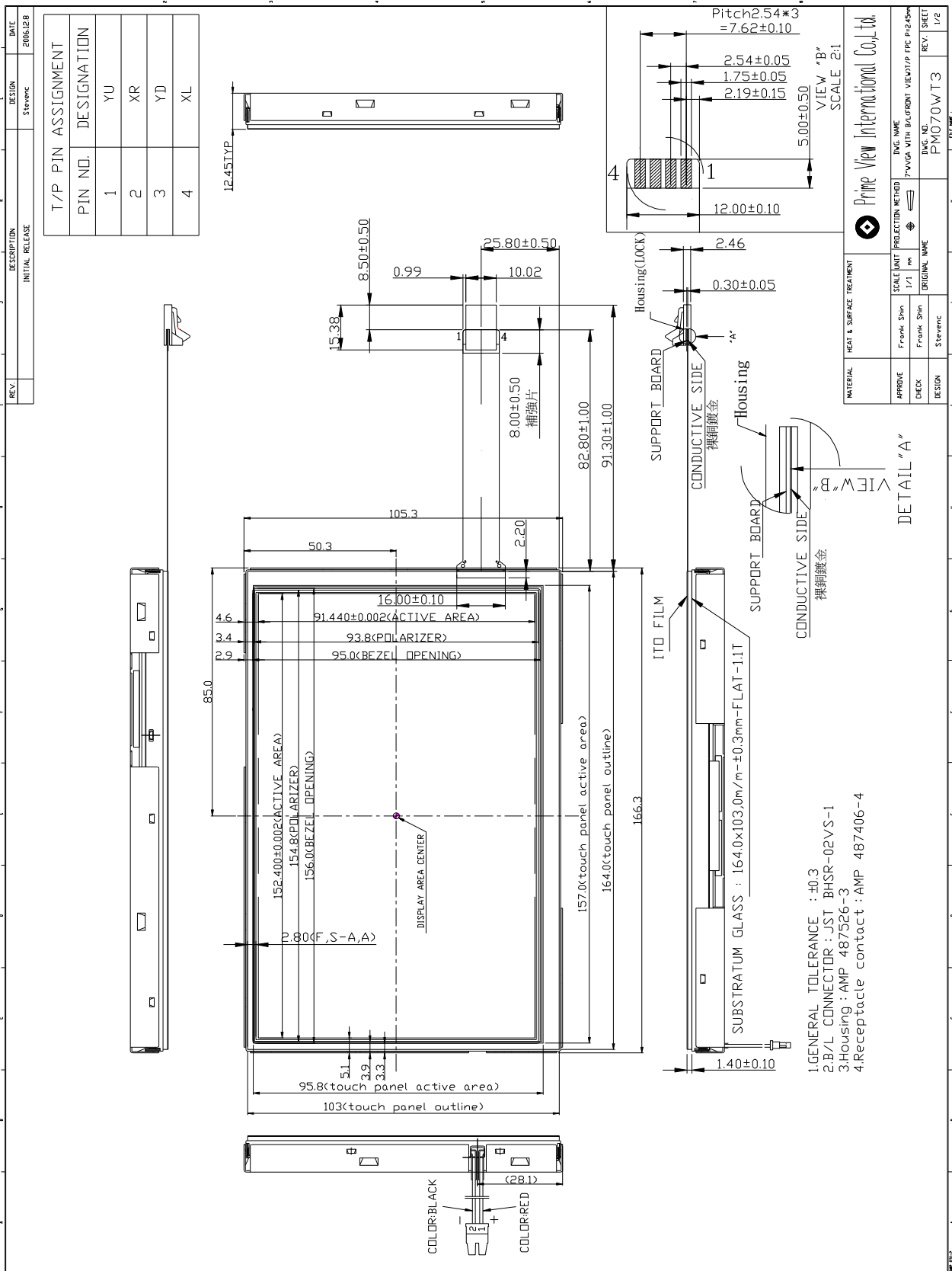

Outline Drawing : Rear View (unit mm)

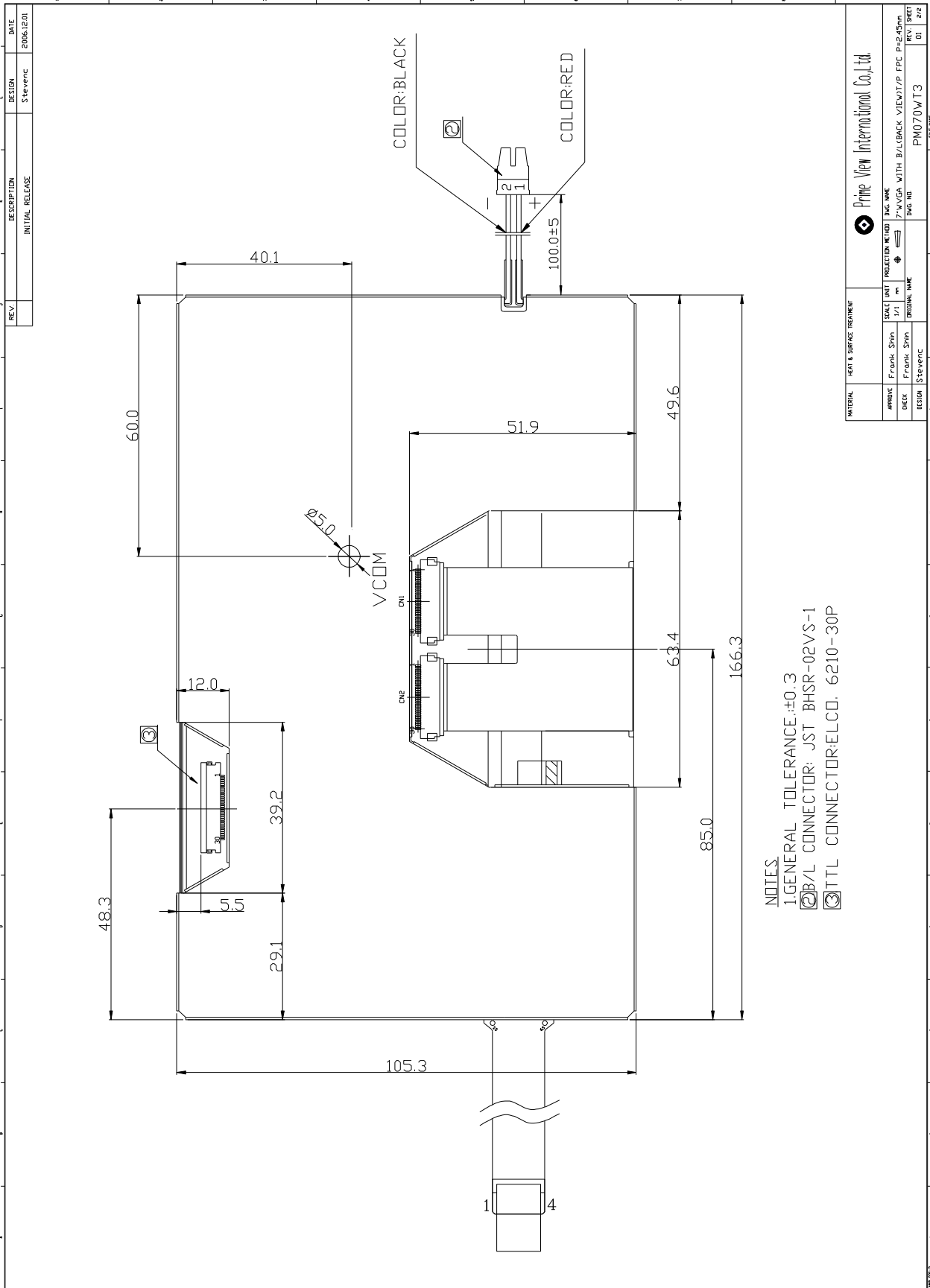

5. Input Terminals

5-1) TFT-LCD Panel Driving

Connector type: ELCO 6210-30P

Pin No.	Symbol	Function	Remark
1	CLK	Clock Signal for Sampling Image Digital Data	
2	Hsync	Horizontal Synchronous Signal	
3	Vsync	Vertical Synchronous Signal	
4	GND	Ground (0V)	
5	R0	Red Image Data Signal (LSB)	
6	R1	Red Image Data Signal	
7	R2	Red Image Data Signal	
8	R3	Red Image Data Signal	
9	R4	Red Image Data Signal	
10	R5	Red Image Data Signal (MSB)	
11	GND	Ground (0V)	
12	G0	Green Image Data Signal (LSB)	
13	G1	Green Image Data Signal	
14	G2	Green Image Data Signal	
15	G3	Green Image Data Signal	
16	G4	Green Image Data Signal	
17	G5	Green Image Data Signal (MSB)	
18	GND	Ground (0V)	
19	B0	Blue Image Data Signal (LSB)	
20	B1	Blue Image Data Signal	
21	B2	Blue Image Data Signal	
22	B3	Blue Image Data Signal	
23	B4	Blue Image Data Signal	
24	B5	Blue Image Data Signal (MSB)	
25	GND	Ground (0V)	
26	DENB	Compound Synchronization signal	Note5-1
27	VCC	DC +3.3V Power Supply	
28	VCC	DC +3.3V Power Supply	
29	R/L	Left / Right control for source driver	Note5-2
30	U/D	Up / Down control for gate driver	Note5-2

Note5-1 DENB input signal.

If customer wanted to off the DENB mode , you must keep the DENB always High or Low.

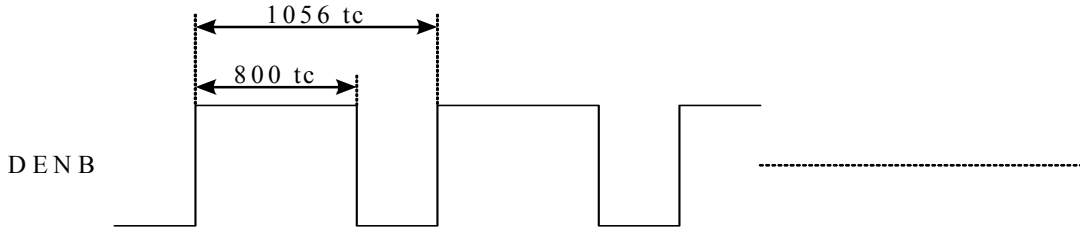

(tc: the period of sampling clock)

Note 5-2 The definitions of U/D & R/L

U/D(PIN 30)=Low R/L(PIN 29)=High

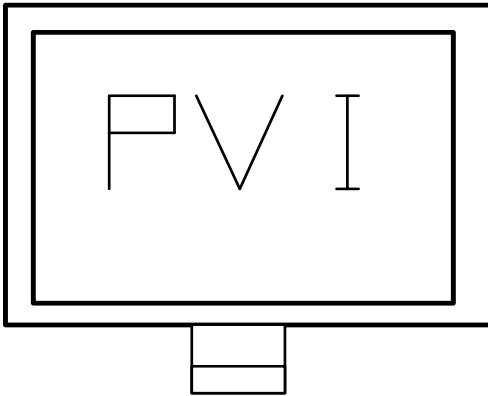

U/D(PIN 30)=High R/L(PIN 29)=Low

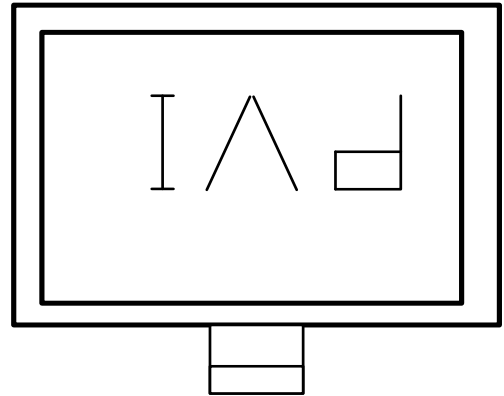

6.Touch Panel Characteristics

6.1) Pin assignment:

Pin	Symbol	Function	Remark
1	YU	Upper electrode Y(Upper side)	
2	XR	Lower electrode X(Right side)	
3	YD	Upper electrode Y(Down side)	
4	XL	Lower electrode X(Left side)	

6.2) Electrical Performance:

Parameters	Symbol	MIN.	Typ.	MAX.	Unit	Remark
Terminal Resistance	X	580	840	1200	Ω	
	Y	120	180	260	Ω	
Input Voltage	V _T	-	5.0	7.0	V	
Linearity(X ,Y direction)	-	-	-	± 1.5	%	
Insulation Impedance	-	20	-	-	M Ω	DC 25V
Response Time	-	-	-	15	ms	
Operation Force	-	-	-	50	g	Note 6-1

Note 6-1 : Input through R0.8mm stylus or R8.0mm finger.

6.3) Durability Performance

1. Hitting Durability:

At least 1,000,000 times with R8.0mm silicon rubber, 250g , 3times/sec .

2. Sliding Durability:

At least 100,000 times with R0.8mm polyacetal stylus , 250g , 60mm/sec.

6.4) Integration Design Guide

Avoid the design that Front-case overlap and press on the active area of the touch-panel.
 Give enough gap (over 0.5mm at compressed) between the front case and touch-panel to protect wrong operating.

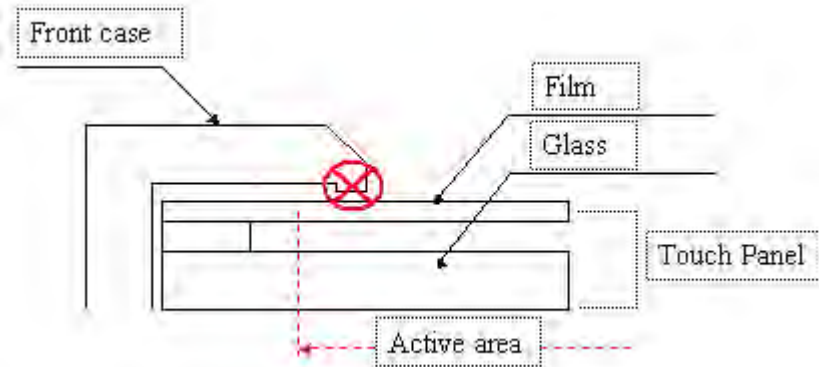

Use a buffer material (Gasket) between the touch-panel and front-case to protect damage and wrong operating.
 Avoid the design that buffer material overlap and press on the inside of touch-panel viewing area.

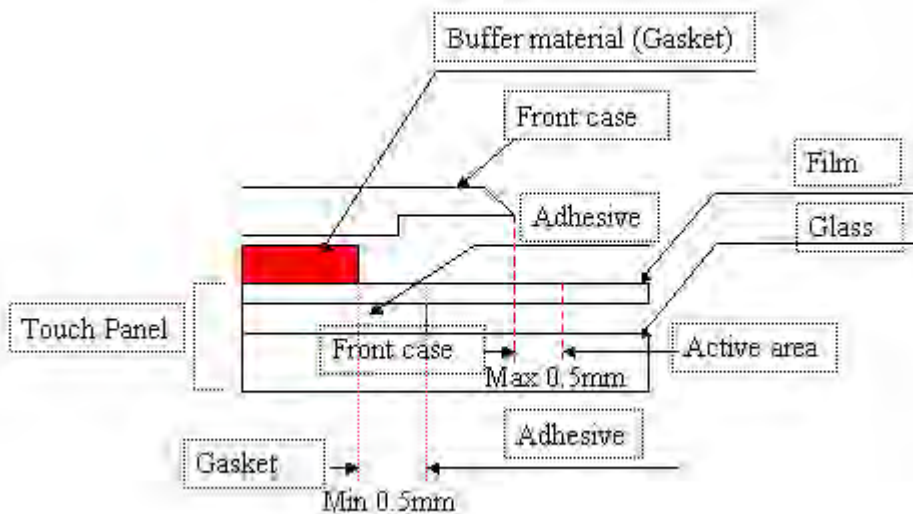

Note : We strongly suggest to follow above design guide to avoid the linear defect happened on the touch panel.

7. Absolute Maximum Ratings:

GND=0V, Ta=25°C

Parameters	Symbol	MIN.	MAX.	Unit	Remark
Supply Voltage	V _{CC}	-0.3	+4.0	V	
Input Signals Voltage	V _{IN}	-0.3	V _{CC} +0.3	V	
Backlight Driving Frequency	F _L	0	100	KHz	

8. Electrical Characteristics

8-1) Recommended Operating Conditions:

GND = 0V , Ta = 25°C

Item	Symbol	Min.	Typ.	Max.	Unit	Remark
Supply Voltage	V _{CC}	3.0	3.3	3.6	V	
Current Dissipation	I _{CC}	-	178.3	194.5	mA	Note 8-1
Digital input voltage	High Level	V _{IN}	0.7 V _{CC}	-	V _{CC}	mV
	Low Level	V _{IL}	-0.1	-	0.1V _{CC}	
V _{com} Voltage	V _{com}	-	3.1	-	V	

Note 8-1 : To test the current dissipation of VCC using the “color bars” testing pattern shown as below

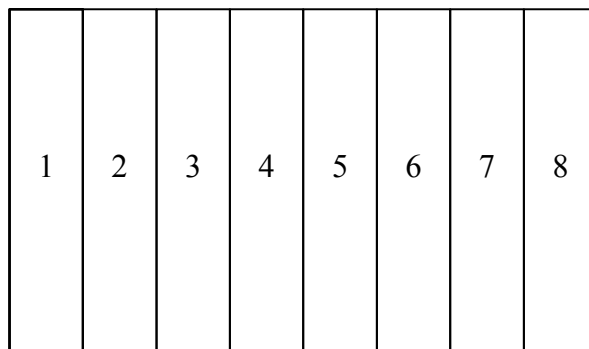

1. White
2. Yellow
3. Cyan
4. Green
5. Magenta
6. Red
7. Blue
8. Black

I_{CC} current dissipation testing pattern

8-2) Backlight driving

Connector type: JST BHSR-02VS-1

Pin No	Symbol	Description	Remark
1	+	Input terminal (Anode)	Wire color : Red
2	-	Input terminal (Cathode)	Wire color : Black

8-3) Recommended Driving Condition for LED Back Light

Ta = 25°C

Parameter	Symbol	Min	TYP	MAX	Unit	Remark
Supply voltage of LED backlight	V _{LED}	9.3	-	10.8	V	Note 8-2
Supply current of LED backlight	I _{LED}	-	20	-	mA	Note 8-3
Backlight Power Consumption	P _{LED}	2.046	-	2.376	W	Note 8-4

Note 8-2 : I_{LED} = 20mA(Constant Current).

Note 8-3 : The LED driving condition is defined for each LED module. (3 LED Serial)

$$\text{Input current} = 20\text{mA} * 11 = 220\text{mA}$$

$$\text{Note 8-4 : } P_{\text{LED}} = V_{\text{LED-1}} * I_{\text{LED-1}} + V_{\text{LED-2}} * I_{\text{LED-2}} \dots + V_{\text{LED-10}} * I_{\text{LED-10}} + V_{\text{LED-11}} * I_{\text{LED-11}}$$

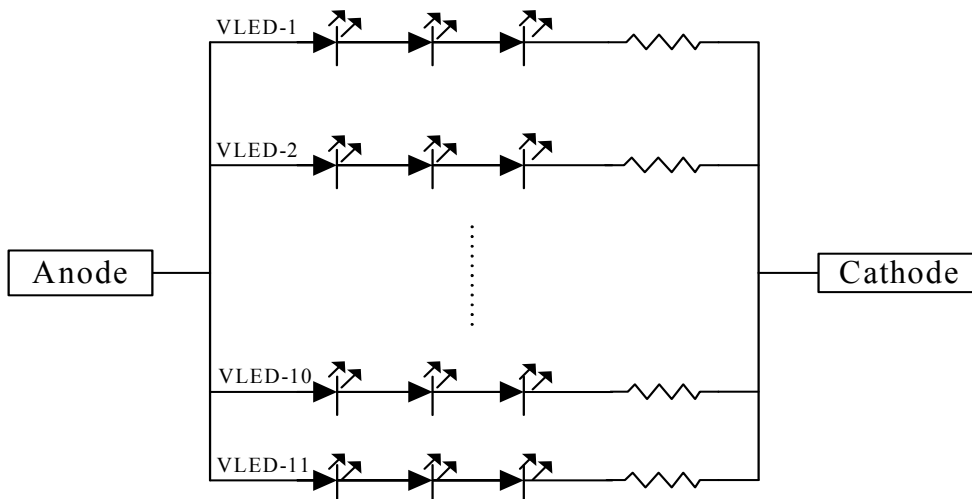

8-4) Power Consumption

Parameter	Symbol	Typ.	Max.	Unit	Remark
LCD Power consumption (W/O BL)	-	0.59	0.71	W	
LED Backlight Power Consumption	-	-	2.376	W	Note 8-5
Total Power Consumption	-	-	3.086	W	

Note 8-5: Backlight lamp power consumption is calculated by $I_L \times V_L$

9. Pixel Arrangement

The LCD module pixel arrangement is the stripe.

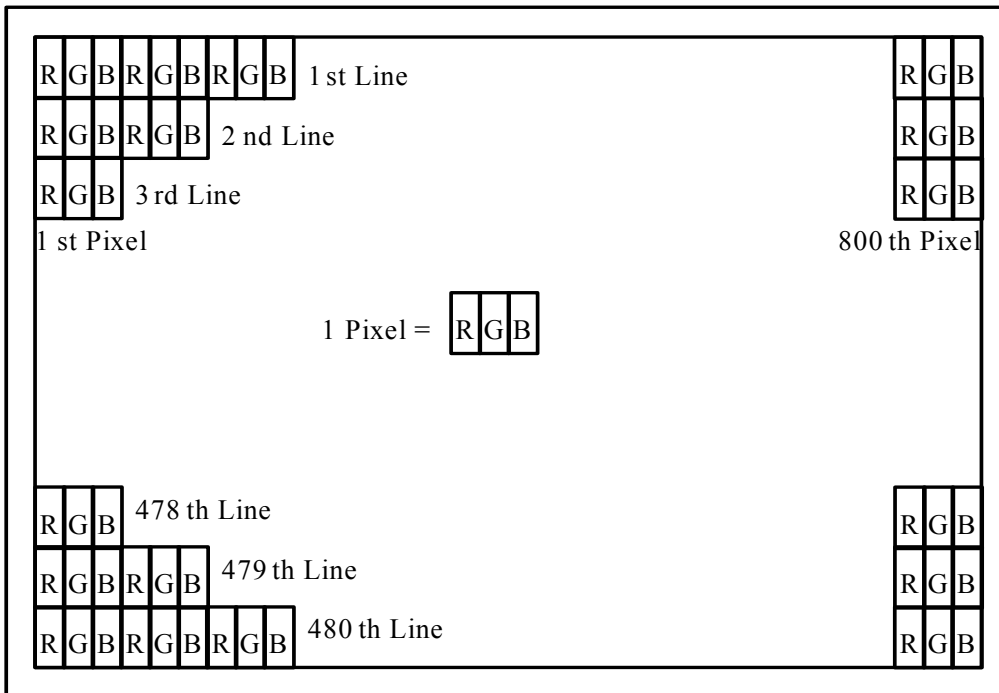

10. Display Color and Gray Scale Reference

Color		Input Color Data																	
		Red						Green						Blue					
		R5	R4	R3	R2	R1	R0	G5	G4	G3	G2	G1	G0	B5	B4	B3	B2	B1	B0
Basic Colors	Black	0	0	0	0	0	0	0	0	0	0	0	0	0	0	0	0	0	0
	Red (63)	1	1	1	1	1	1	0	0	0	0	0	0	0	0	0	0	0	0
	Green (63)	0	0	0	0	0	0	1	1	1	1	1	1	0	0	0	0	0	0
	Blue (63)	0	0	0	0	0	0	0	0	0	0	0	0	1	1	1	1	1	1
	Cyan	0	0	0	0	0	0	1	1	1	1	1	1	1	1	1	1	1	1
	Magenta	1	1	1	1	1	1	0	0	0	0	0	0	1	1	1	1	1	1
	Yellow	1	1	1	1	1	1	1	1	1	1	1	1	0	0	0	0	0	0
	White	1	1	1	1	1	1	1	1	1	1	1	1	1	1	1	1	1	1
Red	Red (00)	0	0	0	0	0	0	0	0	0	0	0	0	0	0	0	0	0	0
	Red (01)	0	0	0	0	0	1	0	0	0	0	0	0	0	0	0	0	0	0
	Red (02)	0	0	0	0	1	0	0	0	0	0	0	0	0	0	0	0	0	0
	Darker																		
	↓	↓	↓	↓	↓	↓	↓	↓	↓	↓	↓	↓	↓	↓	↓	↓	↓	↓	↓
	Brighter																		
	Red (61)	1	1	1	1	0	1	0	0	0	0	0	0	0	0	0	0	0	0
	Red (62)	1	1	1	1	1	0	0	0	0	0	0	0	0	0	0	0	0	0
Red (63)	1	1	1	1	1	1	0	0	0	0	0	0	0	0	0	0	0	0	
Green	Green (00)	0	0	0	0	0	0	0	0	0	0	0	0	0	0	0	0	0	0
	Green (01)	0	0	0	0	0	0	0	0	0	0	0	1	0	0	0	0	0	0
	Green (02)	0	0	0	0	0	0	0	0	0	0	1	0	0	0	0	0	0	0
	Darker																		
	↓	↓	↓	↓	↓	↓	↓	↓	↓	↓	↓	↓	↓	↓	↓	↓	↓	↓	↓
	Brighter																		
	Green (61)	0	0	0	0	0	0	1	1	1	1	0	1	0	0	0	0	0	0
	Green (62)	0	0	0	0	0	0	1	1	1	1	1	0	0	0	0	0	0	0
Green (63)	0	0	0	0	0	0	1	1	1	1	1	1	0	0	0	0	0	0	
Blue	Blue (00)	0	0	0	0	0	0	0	0	0	0	0	0	0	0	0	0	0	0
	Blue (01)	0	0	0	0	0	0	0	0	0	0	0	0	0	0	0	0	0	1
	Blue (02)	0	0	0	0	0	0	0	0	0	0	0	0	0	0	0	0	1	0
	Darker																		
	↓	↓	↓	↓	↓	↓	↓	↓	↓	↓	↓	↓	↓	↓	↓	↓	↓	↓	↓
	Brighter																		
	Blue (61)	0	0	0	0	0	0	0	0	0	0	0	0	1	1	1	1	0	1
	Blue (62)	0	0	0	0	0	0	0	0	0	0	0	0	1	1	1	1	1	0
Blue (63)	0	0	0	0	0	0	0	0	0	0	0	0	1	1	1	1	1	1	

11. Block Diagram

11-1) TFT-module Block Diagram

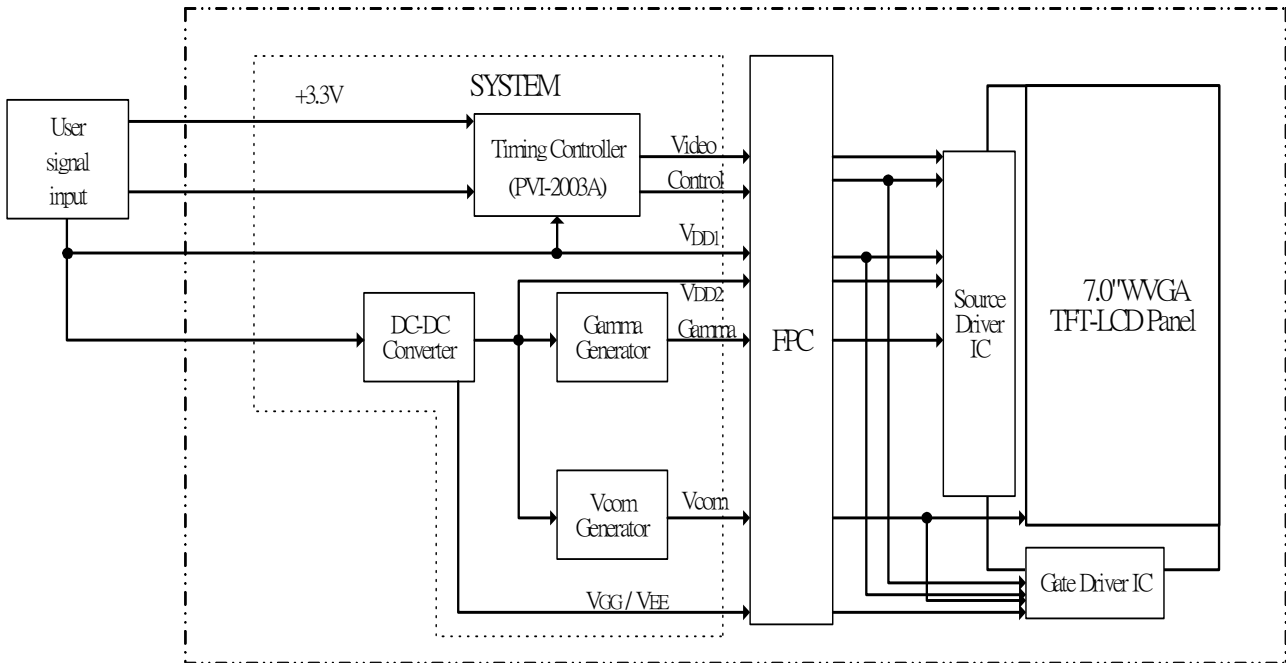

12. Interface Timing

12.1) Timing Parameters

		Symbol	Min.	Typ.	Max.	Unit	Remark	
Power supply		VCC	3.0	3.3	3.6	V		
CLK	Frequency	1/tc	-	32	-	MHz		
		tc	-	31.25	-	ns		
HSYNC	Period	Hp	-	33	-	us		
			-	1056	-	tc		
	Display period	Hdp	-	800	-	tc		
	Pulse width	Hpw	-	128	-	tc		
	Back-porch	Hbp	-	86	-	tc		
	Front-porch	Hfp	-	42	-	tc		
	Hpw+Hbp			-	214	-	tc	
	Hsync-CLK	Hhc	10	-	Tc-10	ns		
	Vsync-Hsync	Hvh	0	0	200	tc		
VSYNC	Period	Vp	-	17.325	-	ms		
			-	525	-	Hp		
	Display period	Vdp	-	480	-	Hp		
	Pulse width	Vpw	-	2	-	Hp		
	Back-porch	Vbp	-	33	-	Hp		
	Front-porch	Vfp	-	10	-	Hp		
	Vpw+Vbp			-	35	-	Hp	
DENB	Horizontal scanning period	T1	860	1056	1064	tc		
	Horizontal display period	T2	-	800	-	tc		
	Vertical display period	T3	-	480	-	T1		
	Frame cycling period	T4	520	525	800	T1		
R,G,B	CLK-DATA	Dcd	10	-	-	ns		
	DATA-CLK	Ddc	8	-	-	ns		

12.2) The Timing Diagram

A. The timing chart for DENB mode
 a-1 CLK data ,relationship

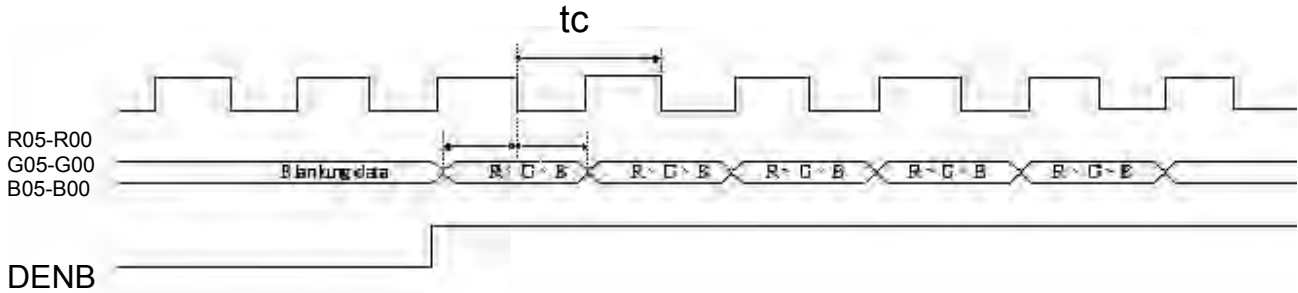

a-2 DENB Timing

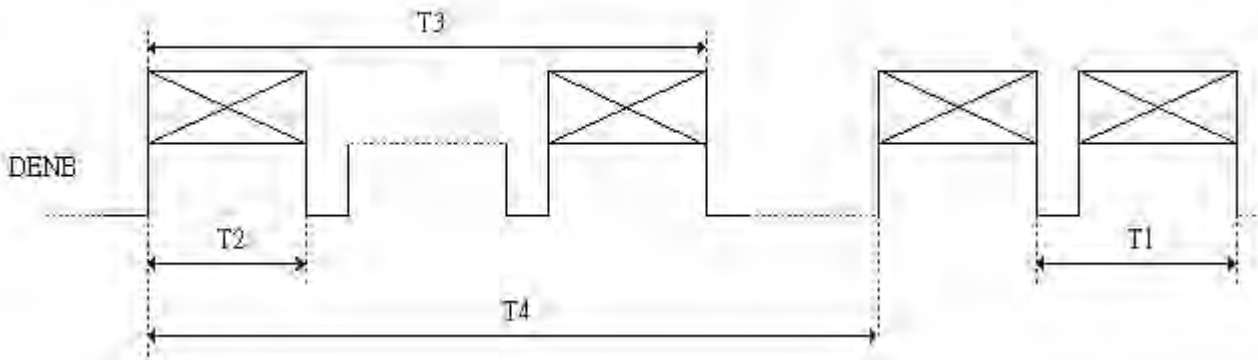

B. The timing chart for sync mode

b-1 CLK Hsync relation ship



b-2 Hsync timing

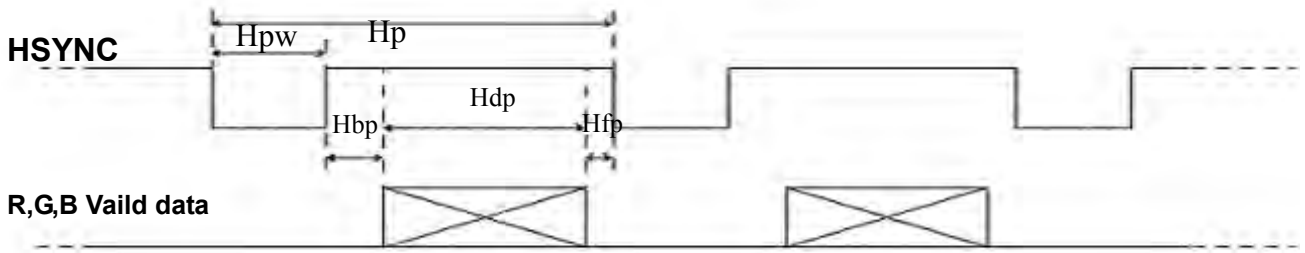

b-3 Hsync ,Vsync relation ship

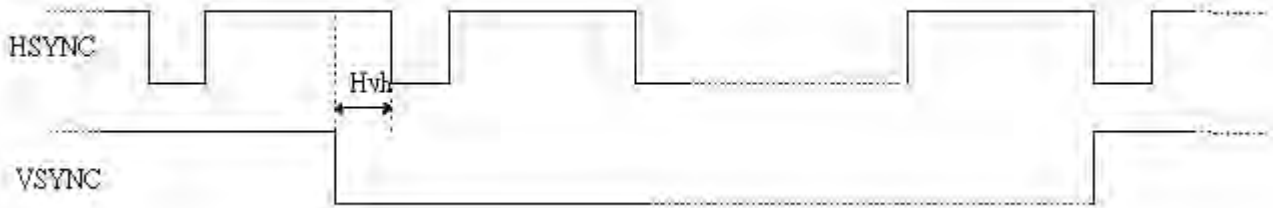

b-4 Vsync Timing

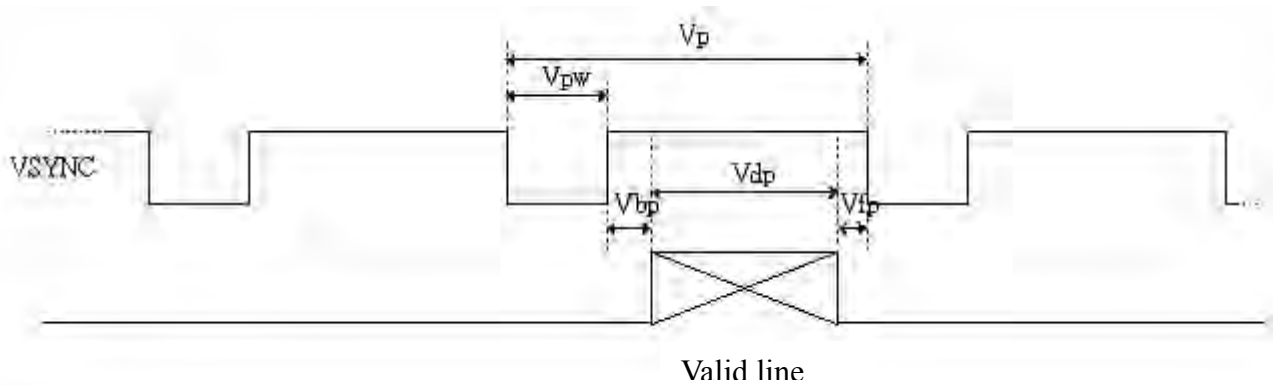

13. Power On Sequence

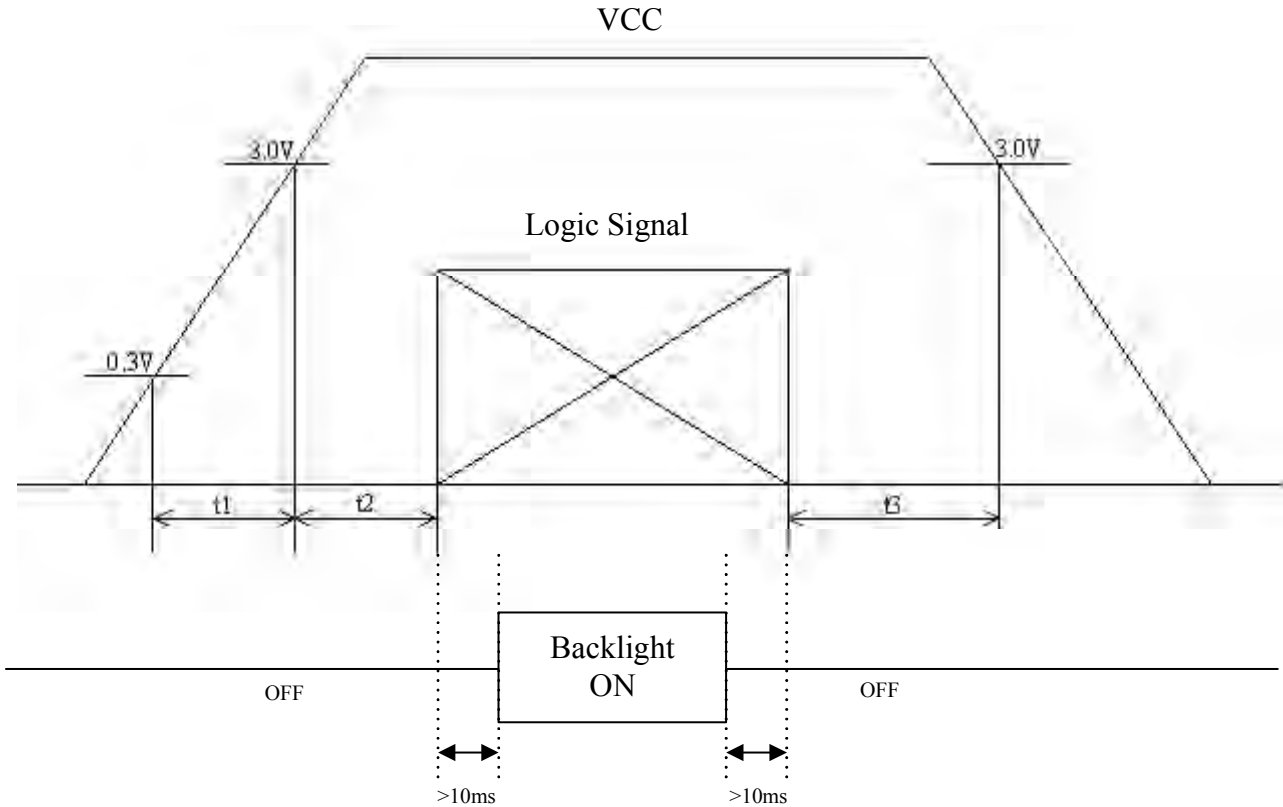

1. $0 < t1 \leq 20ms$
2. $0 < t2 \leq 50ms$
3. $0 < t3 \leq 1s$

14. Optical Characteristics

14-1) Specification:

Ta=25°C

Parameter	Symbol	Condition	MIN.	TYP.	MAX.	Unit	Remarks
Viewing Angle	Horizontal	θ 21.22	± 55	± 60	-	deg	Note 14-1
	Vertical	θ 12 (to 12 'clock)	35	40	-	deg	
		θ 11 (to 6 o'clock)	50	55	-	deg	
Contrast Ratio	CR	$\theta = 0^\circ / \varphi = 0$	250	400	-	-	Note 14-2
Response time	Rise	Tr	-	15	30	ms	Note 14-3
	Fall	Tf	-	25	50	ms	
Brightness	L	$\theta = 0^\circ / \varphi = 0$	280	330	-	cd/m ²	
Luminance Uniformity	U	-	70	75	-	%	Note 14-4
White Chromaticity	x	$\theta = 0^\circ / \varphi = 0$	0.27	0.31	0.35	-	
	y		0.29	0.33	0.37	-	
Cross Talk	-	$\theta = 0^\circ$	-	-	3.5	%	Note 14-5
LED Life Time	-	-	20000	30000	-	hr	Note 14-6

All the optical measurement shall be executed 10 minutes after backlight being turn-on. The optical characteristics shall be measured in dark room (ambient illumination on panel surface less than 1 Lux). The measuring configuration shows as following figure.

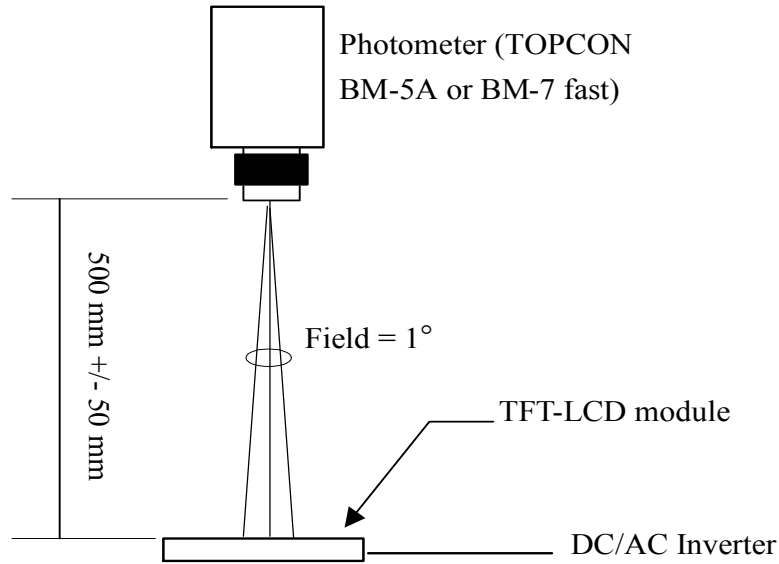

Optical characteristics measuring configuration

Topcon BM-5A or BM-7 fast luminance meter 1° field of view is used in the testing (after 10 minutes' operation). The typical luminance value is measured at LED current 20 mA.

Note 14-1: The definitions of viewing angles are as follow.

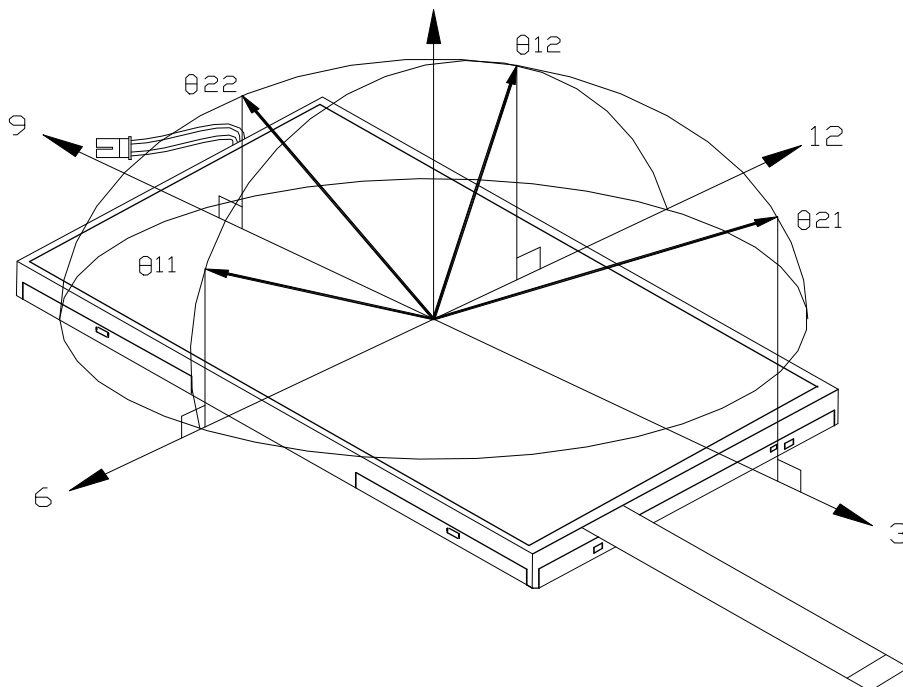

Note 14-2: The definition of contrast ratio $CR = \frac{\text{Luminance at gray level 63}}{\text{Luminance at gray level 0}}$

Note 14-3: Definition of Response Time T_r and T_f :

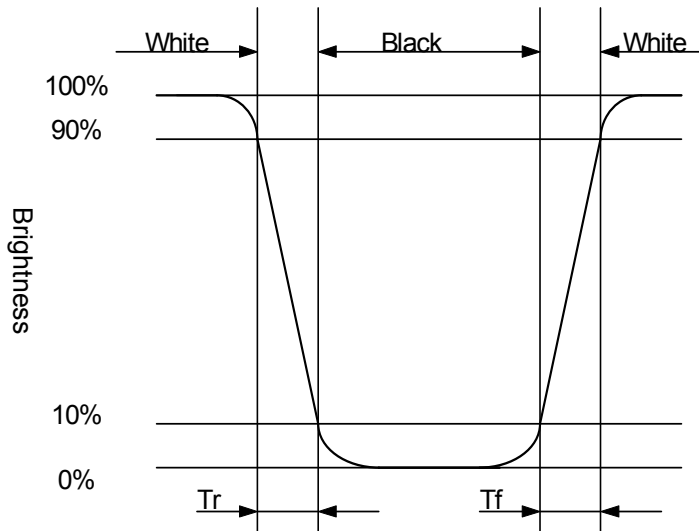

Note 14-4: The uniformity of LCD is defined as

$$U = \frac{\text{The Minimum Brightness of the 9 testing Points}}{\text{The Maximum Brightness of the 9 testing Points}}$$

- Luminance meter : BM-5A or BM-7 fast(TOPCON)
- Measurement distance : 500 mm +/- 50 mm
- Ambient illumination : < 1 Lux
- Measuring direction : Perpendicular to the surface of module
- The test pattern is white (Gray Level 63).

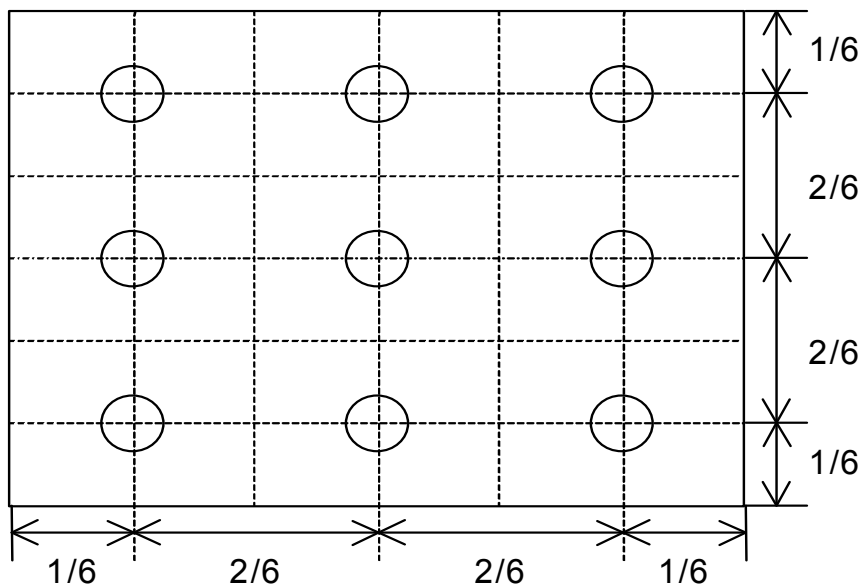

Note 14-5: Cross Talk (CTK) = $\frac{|Y_A - Y_B|}{Y_A} \times 100\%$

YA: Brightness of Pattern A
 YB: Brightness of Pattern B
 Luminance meter : BM 5A or BM-7 fast (TOPCON)
 Measurement distance : 500 mm +/- 50 mm
 Ambient illumination : < 1 Lux
 Measuring direction : Perpendicular to the surface of module

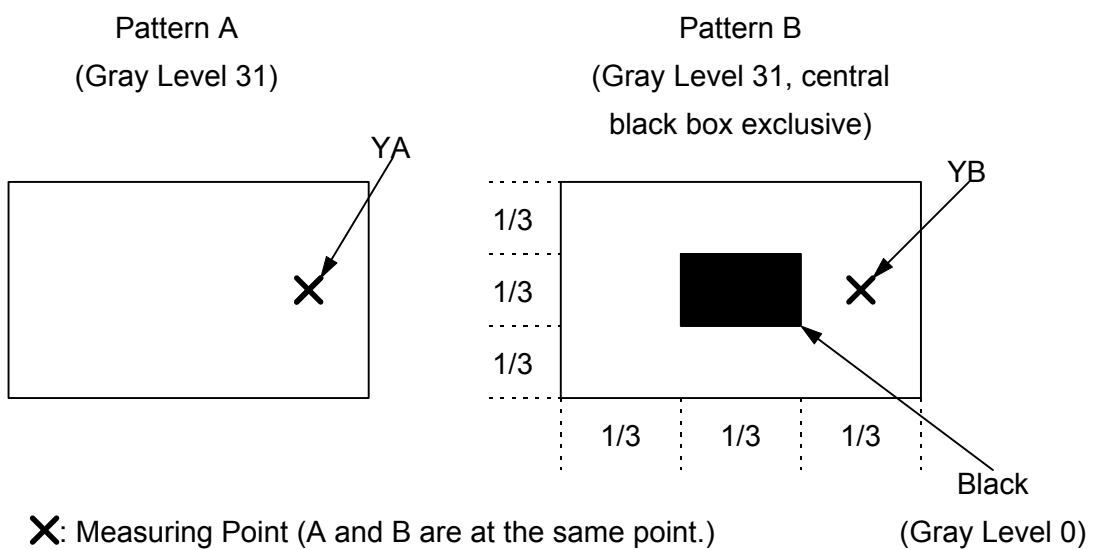

Note 14-6: The “LED Life time “ is defined as the module brightness decrease to 50% original Brightness that the ambient temperature is 25°C and I_{LED} =20mA.

15. Handling Cautions

15-1) Mounting of module

- a) Please power off the module when you connect the input/output connector.
- b) Polarizer which is made of soft material and susceptible to flaw must be handled carefully.
- c) Protective film (Laminator) is applied on surface to protect it against scratches and dirt.
- d) Please following the tear off direction as figure15-1 to remove the protective film as slowly as possible, so that electrostatic charge can be minimized.

15-2) Precautions in mounting

- a) When metal part of the TFT-LCD module (shielding lid and rear case) is soiled, wipe it with soft dry cloth.
- b) Wipe off water drops or finger grease immediately. Long contact with water may cause discoloration or spots.
- c) TFT-LCD module uses glass which breaks or cracks easily if dropped or bumped on hard surface. Please handle with care.
- d) Since CMOS LSI is used in the module. So take care of static electricity and earth yourself when handling.

15-3) Adjusting module

- a) Adjusting volumes on the rear face of the module have been set optimally before shipment.
- b) Therefore, do not change any adjusted values. If adjusted values are changed, the specifications described may not be satisfied.

15-4) Polarizer mark

The polarizer mark is to describe the direction of wide view angle film how to mach up with the rubbing direction.

15-5) Others

- a) Do not expose the module to direct sunlight or intensive ultraviolet rays for many hours.
- b) Store the module at a room temperature place.
- c) The voltage of beginning electric discharge may over the normal voltage because of leakage current from approach conductor by to draw lump read lead line around.
- d) If LCD panel breaks, it is possibly that the liquid crystal escapes from the panel. Avoid putting it into eyes or mouth. When liquid crystal sticks on hands, clothes or feet. Wash it out immediately with soap.
- e) Observe all other precautionary requirements in handling general electronic components.
- f) Please adjust the voltage of common electrode as material of attachment by 1 module.

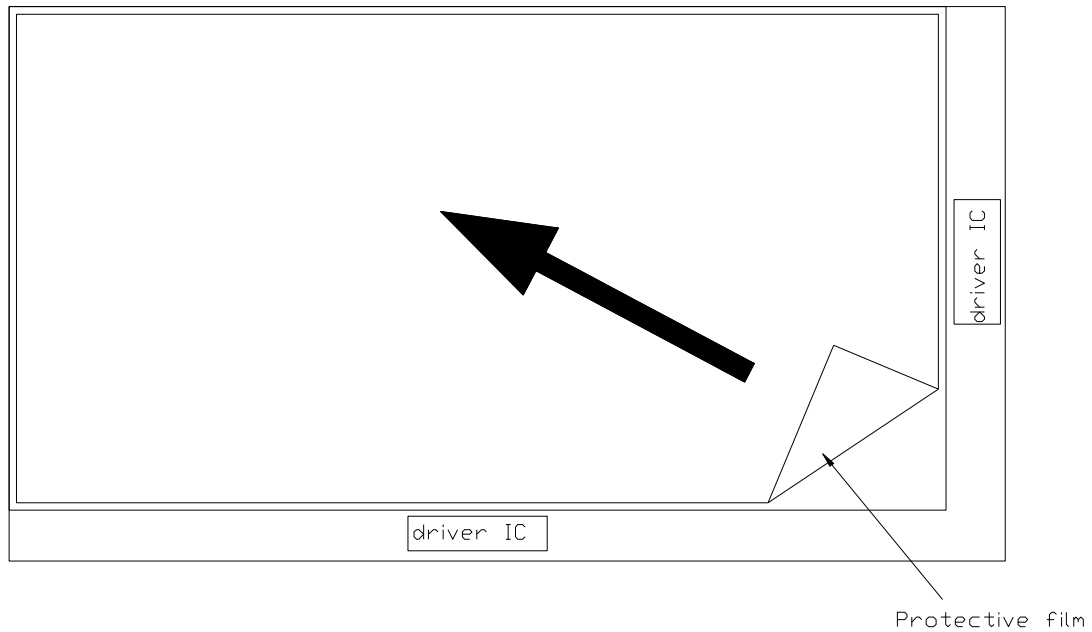

Figure 15-1 the way to peel off protective film

16. Reliability Test

No	Test Item	Test Condition	Remark
1	High Temperature Storage Test	Ta = +80°C, 240 hrs	
2	Low Temperature Storage Test	Ta = -40°C, 240 hrs	
3	High Temperature Operation Test	Ta = +70°C, 240 hrs	
4	Low Temperature Operation Test	Ta = -20°C, 240 hrs	
5	High Temperature & High Humidity Operation Test	Ta = +60°C, 90%RH, 240 hrs (No Condensation)	
6	Thermal Cycling Test (non-operating)	-30°C → +80°C, 100 Cycles 30min 30min	
7	Vibration Test (non-operating)	Frequency : 10 ~ 55 Hz, Amplitude : 1 mm Sweep time: 11 min Test Period: 6 Cycles for each direction of X, Y, Z	
8	Shock Test (non-operating)	100G, 6ms Direction: ±X, ±Y, ±Z Cycle: 3 times	
9	Electrostatic Discharge Test (non-operating)	Contact mode: ±8KV, 10times/point , 9 points/panel face Air mode: 150pF, 330Ω Air : ±15KV	
10	Hitting Durability Test (Touch panel)	1,000,000 times, with R 8.0 mm silicon rubber, 250g, 3times/sec	
11	Sliding Durability Test (Touch panel)	100,000 times, with R 0.8 mm polyacetal stylus, 250g, 60mm/sec	

Ta: ambient temperature

Note: The protective film must be removed before temperature test.

[Criteria]

In the standard conditions, there is not display function NG issue occurred. (including : line defect ,no image), All the cosmetic specification is judged before the reliability stress.

17. Packing Diagram

ZONE	REV.	DOCUMENT NO.	DESCRIPTION	DATE	REV. BY
<p>NOTE:</p> <p>1. QTY: 40 pcs panel/carton. 2. Dimension: 530*295*230mm 3. Weight: 15.2 Kg</p>					
4		50-0100111	CARTON	1	
3		50-0500071	PINK Bag 190*190mm	40	抗静电袋
2		PM070WT3		40	
1		50-0301681	瓦楞隔板缓冲材料	1	上盖+底座
ITEM		PART NO.		QTY	REMARK
MTL.SPEC.		UNSPECIFIED TOL'S		REMARK	
		ANGLE			
		ROUGHNESS			
APPROVE	Frank Shin	06.12.14	SCALE	UNIT	SHEET
CHECK	Frank Shin	06.12.14			1 of 1
DRAWN	Stevenc	06.12.14	MTL.NO.		DWG FILE:
				REV. 01	A4 SIZE

元太科技工業股份有限公司
 Prime View International Co., Ltd.