

 PM Motor
PM Type

Reference Characteristics

Motor Size	PM42S-096	
Number of Steps per Rotation	96(3.75°/Step)	
Drive Method	2-2 PHASE	
Drive Circuit	UNIPOLAR CONST. VOLT.	BIPOLAR CHOPPER
Drive Voltage	24[V]	24[V]
Current/Phase		500[mA]
Coil Resistance/Phase	90[Ω]	10[Ω]
Drive IC	2SC3346	UDN2916B-V
Magnet Material	Nd-Fe-B bonded magnet (MS70)	
Insulation Resistance	100M[Ω] MIN	
Dielectric Strength	AC 500[V] 1[min]	
Class of Insulation	CLASS E	
Operating Temp.	-10[°C] ~ 50[°C]	
Storage Temp.	-30[°C] ~ 80[°C]	
Operating Hum.	20[%] RH ~ 90[%] RH	

Applications

- OA Equipment : Printers / Scanners
- Industrial equipment : Flow control valves
- Toys : Slot machines
- Home automation appliances : Sewing machines

Torque Characteristics

PM42S-096 UNI-CONST. V (at 24[V],90[Ω])

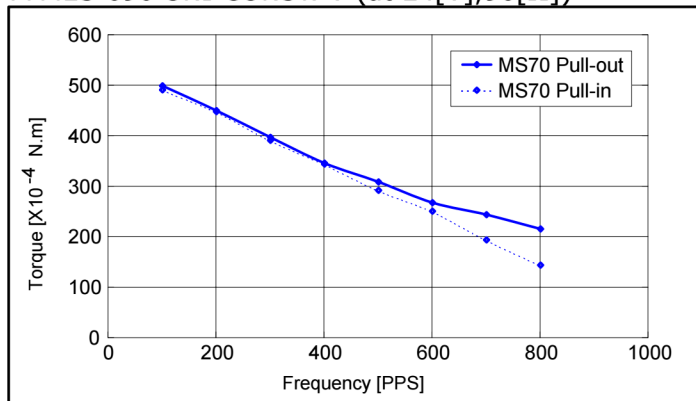

PM42S-096 BI-CHOPPER (at 24[V],10[Ω],500[mA])

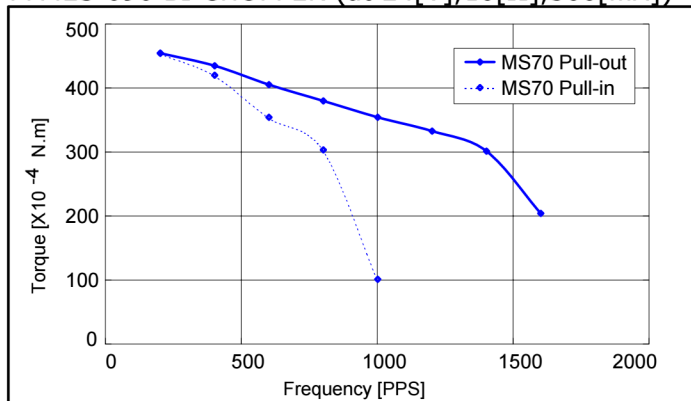

These torque values are reference only. Heat radiation conditions and temperature rise effect by duty are different on each equipment, therefore please select motors after considering the heat conditions in the actual equipment.

Dimensions

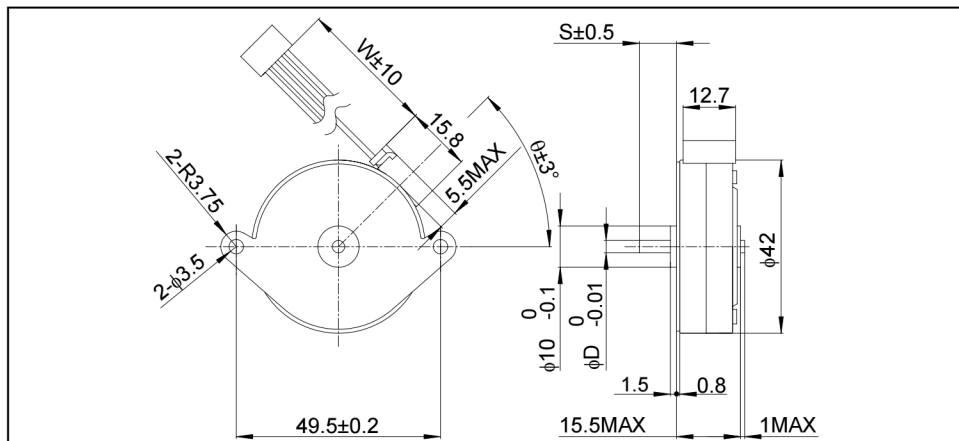

If you would like to know this Dimensions(D,S,W,θ), Please see Standard Dimensions in our Home Page.