



PM8800A

Integrated IEEE 802.3af compliant PoE-PD interface and PWM controller with support of external source

Features

- IEEE 802.3af compliant PD interface
- Works with power supplied from Ethernet LAN cables or from local auxiliary sources
- Integrated 100 V, 0.5 Ω , 800 mA hot-swap MOSFET
- Integrated signature resistor
- Programmable in-rush current limit
- Programmable classification current
- Programmable DC current limit up to 800 mA
- High voltage start-up bias regulator
- Thermal shutdown protection
- Current mode pulse width modulator
- Programmable oscillator frequency
- Programmable soft-start
- Power good indication
- 80 % maximum duty cycle with internal slope compensation
- Supports both isolated and non-isolated Applications.
- HTSSOP16 package

Applications

- VoIP phones, WLAN access points
- Security cameras
- PoE powered device appliances
- High power (>12.95 W) powered devices



Description

The PM8800A integrates a standard power over Ethernet (PoE) interface and a current mode PWM controller to simplify the design of the power supply sections of all powered devices.

The PoE interface incorporates all the functions required by the IEEE 802.3af including detection, classification, under-voltage lockout (UVLO) and in-rush current limitation.

PM8800A specifically targets PD with extended power requirement with respect to the limit imposed by the 802.3af standard, embedding a hot-swap MOSFET capable of sustaining twice the current of the 802.3af standard with a programmable DC current limit.

The integrated switching regulator has been designed to work with power either from the Ethernet cable connection or from an external power source such as AC adapter.

The DC-DC section of the PM8800A features a programmable oscillator frequency, soft-start, slope compensation and embeds a voltage output error amplifier allowing use in both isolated and non isolated configuration.

Table 1. Device summary

Order codes	Package	Packing
PM8800A	HTSSOP16	Tube
PM8800ATR	HTSSOP16	Tape and reel

Contents

1	Typical application circuit and block diagram	4
1.1	Application circuits	4
1.2	Block diagram	5
2	Pins description and connection diagrams	6
2.1	Pin descriptions	6
2.2	Thermal data	8
3	Electrical specifications	9
3.1	Absolute maximum ratings	9
3.2	Electrical characteristic	10
4	Device description and operation	14
5	PD interface	16
5.1	Detection	16
5.2	Classification	17
5.3	Under voltage lock-out	18
5.4	In rush current limit	18
5.5	Continuous current limitation	20
5.6	HV regulator startup	21
5.7	Power good indication	22
6	PWM section	23
6.1	Error amplifier and loop compensation	23
6.2	Oscillator and sync capability	24
6.3	Soft start	25
6.4	PWM comparator / slope compensation	26
6.5	Current limiting	26
6.6	Leading edge blanking	28
6.7	Thermal protection	28

7	Auxiliary sources	29
8	Package mechanical data	32
	8.1 HTSSOP16 mechanical data	33
9	Revision history	34

1 Typical application circuit and block diagram

1.1 Application circuits

Figure 1. Simplified application schematic for powered devices using PM8800A in isolated configuration

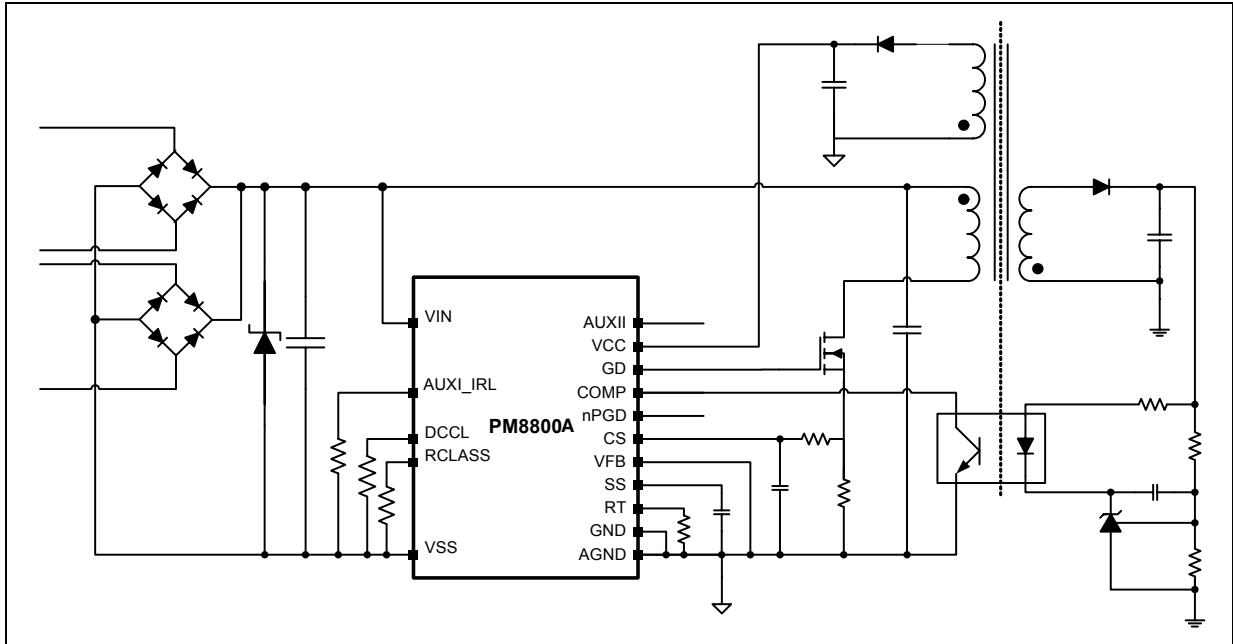
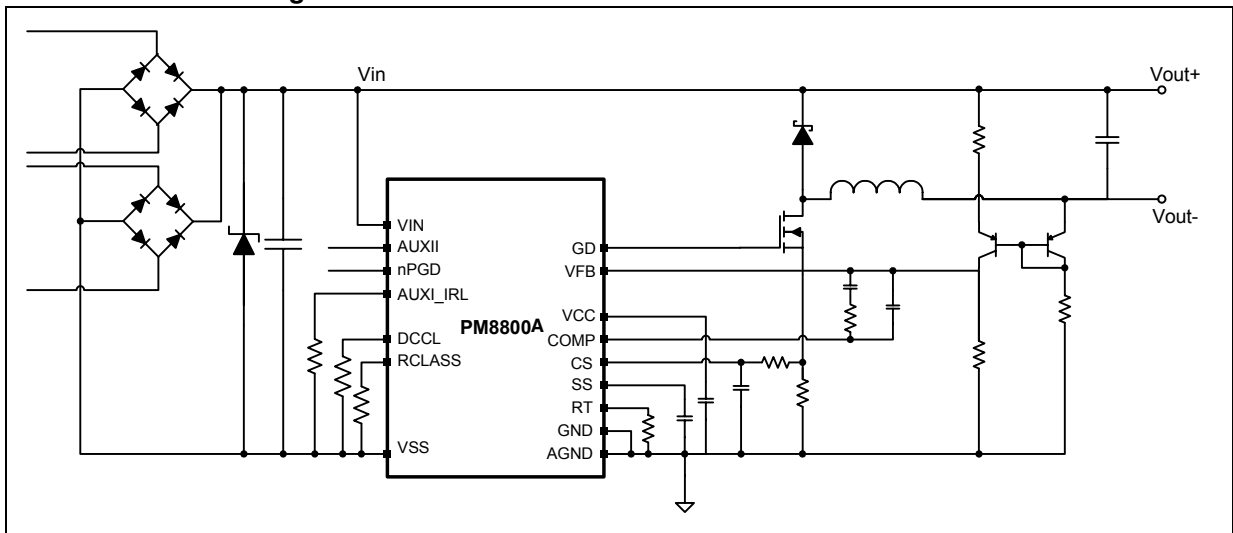

Figure 2. Simplified application schematic for powered device using PM8800A in non-isolated buck configuration



1.2 Block diagram

Figure 3. Block diagram of the PoE PD interface

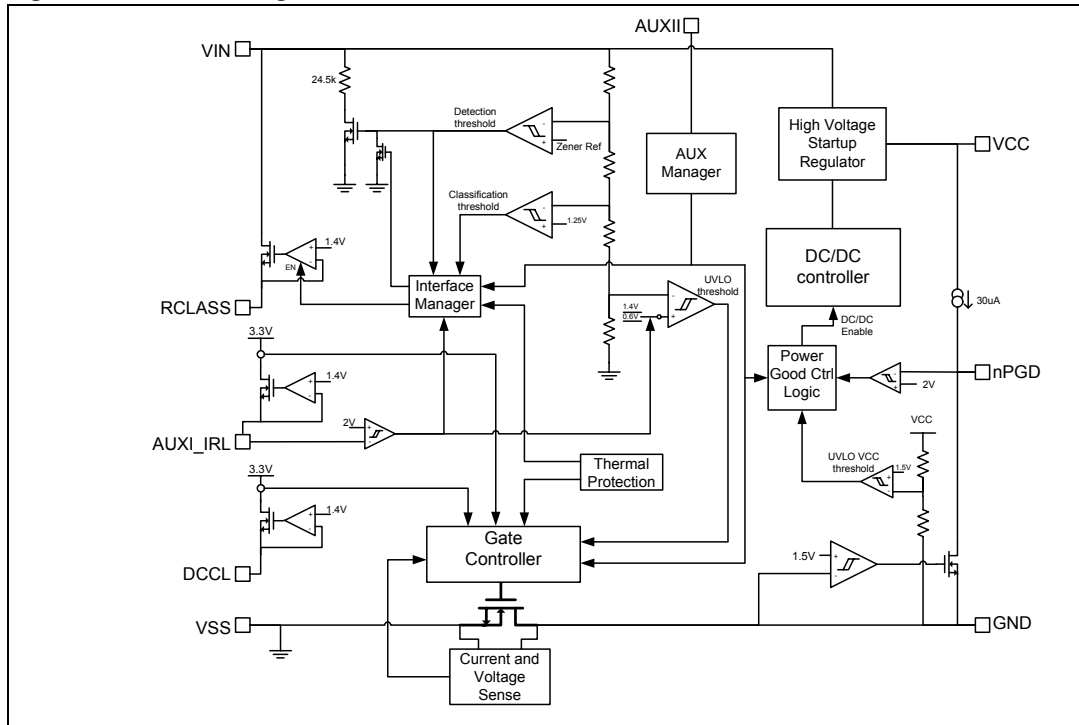
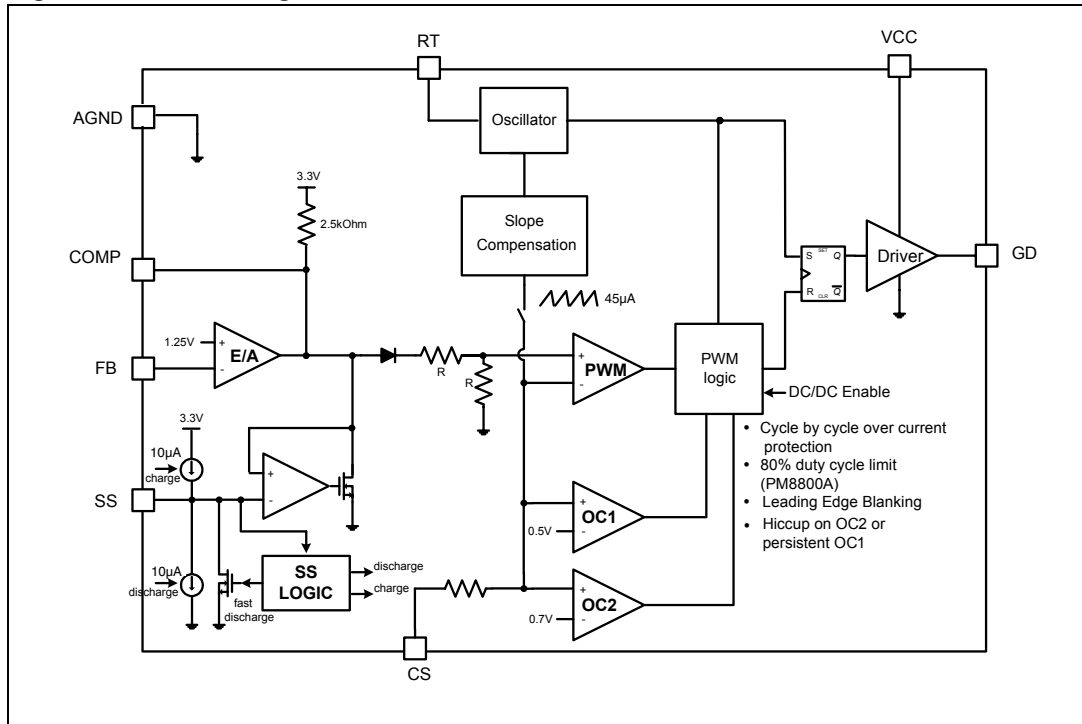
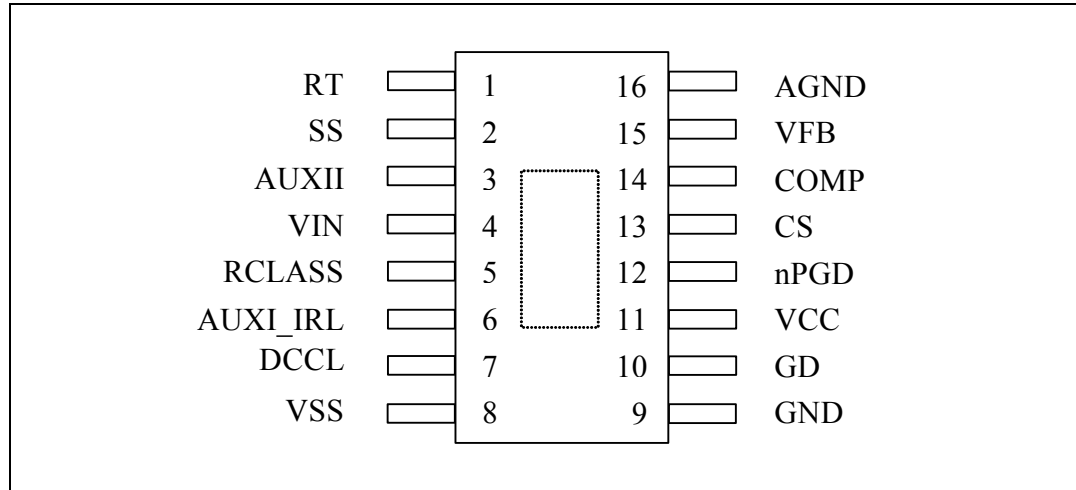

Figure 4. Block diagram of the current mode PWM controller



2 Pins description and connection diagrams

Figure 5. Pins connection (top view)



2.1 Pin descriptions

Table 2. Pin description

Pin#	Name	Function
1	RT	Oscillator timing resistor pin and synchronization input. An external resistor connected from RT to AGND sets the oscillator frequency. This pin will also accept narrow ac-coupled synchronization pulses from an external clock.
2	SS	Soft-start input. An external capacitor connected from SS and AGND and an internal 10 μ A current source set the soft-start ramp rate. this pin is also used to set the hiccup timer in case of overcurrent conditions. See Section 6 for detail.
3	AUXII	Auxiliary source enable pin. Use this pin to power up the DC/DC section only from the external source. The auxiliary source can prevail over the PoE source depending on the value of the resistor between this pin and the external source. See Section 7 for detail.
4	VIN	System high potential input. The diode “OR” of PoE line and auxiliary sources connected to the PD, it is the most positive input potential.
5	RCLASS	Classification resistor pin. Connect a classification programming resistor between this pin and VSS.
6	AUXI_IRL	In-rush current limit and auxiliary source enable pin. Pulling up this pin to the auxiliary source will change the internal UVLO settings and allow PD to be powered with voltage lower than nominal PoE voltages. In this condition inrush current limit is set to default values. See Section 7 for details. A resistance between this pin and VSS will set the level of inrush current limit.

Table 2. Pin description (continued)

Pin#	Name	Function
7	DCCL	DC current limit. A resistor between DCCL and VSS will set the current limit for the interface section of the PM8800A. It can be set to exceed the IEEE802.3af current limit. Leave the pin open for standard IEEE 802.3af applications.
8	VSS	System low potential input.
9	GND	System return for the PWM converter. It is the drain of the internal hot-swap power MOSFET.
10	GD	Output of the PWM controller. External power MOSFET gate driver output.
11	VCC	Output of the internal high voltage regulator. When the auxiliary transformer winding (if used) raises the voltage on this pin above the regulation set point, the internal regulator will be switched off, reducing the controller power dissipation.
12	nPGD	Power good, active low signal. A high to low transition indicates that the inrush current phase has been completed, the internal hot swap MOSFET is fully closed and the SMPS portion of the PM8800A is activated.
13	CS	Current sense input. Current sense input for current mode control and over-current protection. Current limiting is obtained with a dedicated current sense comparator. If the CS pin voltage exceeds 0.5 V the GD pin switches low for cycle-by-cycle current limiting. Leading edge blanking is implemented to mask current spikes.
14	COMP	The output of the error amplifier and input of the Pulse Width Modulator. COMP pull-up is provided by an internal 2.5 k Ω resistor which may be used to bias an opto-coupler transistor.
15	VFB	Feedback signal. Inverting input of the internal error amplifier. The non-inverting input is internally connected to a 1.25 V reference. If not used must be grounded to AGND.
16	AGND	Analog PWM supply return. GND for sensitive analog circuitry including the SMPS current limit circuitry. Must be connected to GND to improve noise immunity.
	EP	Exposed pad. Connect this to a board plane to improve heat dissipation; must be electrically connected to VSS

2.2 Thermal data

Table 3. Thermal data

Symbol	Parameter	Value	Unit
R_{thJA}	Max thermal resistance junction to ambient ⁽¹⁾	50	°C/W
T_{MAX}	Maximum junction temperature	150	°C
T_{STG}	Storage temperature range	-40 to 150	°C
T_J	Junction temperature range	-40 to 125	°C
T_A	Operative temperature range	-40 to 85	°C

1. Package mounted on 4 layers 35 micron demoboard

3 Electrical specifications

3.1 Absolute maximum ratings

Table 4. Absolute maximum ratings

Parameter	Value	Unit
VIN, GND to VSS	-0.3 to 100	V
AUXI_IRL to VSS	-0.3 to 100	V
DCCL, RCLASS to VSS	-0.3 to 3.6	V
AUXII to AGND	-0.3 to 100	V
COMP, SS to AGND	-0.3 to 3.6	V
VFB, RT, CS to AGND	-0.3 to 3.6	V
VCC, GD to AGND	-0.3 to 15	V
nPGD to AGND	-0.3 to 15	V
GND to AGND	-0.3 to 0.3	V

Note: Absolute maximum ratings are limits beyond which damage to the device may occur.

3.2 Electrical characteristic

Table 5. Electrical characteristics - interface section

($V_{IN} = 48\text{ V}$, $V_{CC} = \text{open}$, $T_A = 25\text{ °C}$ unless otherwise specified).

Symbol	Parameter	Test conditions	Min	Typ	Max	Unit
Detection and classification						
	Signature enable	V_{IN} rising			1.5 ⁽¹⁾	V
	Signature resistance		23.5 ⁽¹⁾	24.5	25.5 ⁽¹⁾	k Ω
	Signature disable classification turn on	V_{IN} rising	10.5 ⁽¹⁾	11.5	12.5 ⁽¹⁾	V
	Classification turn on hysteresis			1.40		V
	Classification turn-off	V_{IN} rising	21.5 ⁽¹⁾	23	24.5 ⁽¹⁾	V
	RCLASS voltage during classification		1.37 ⁽¹⁾	1.4	1.43 ⁽¹⁾	V
	Supply current during classification	V_{IN} inside classification range		1.8		mA
Bias current						
IIN	V_{IN} supply current	$V_{IN} = 48\text{ V}$; $V_{CC} = 10\text{ V}$		3		mA
Under Voltage Lock-Out						
V_{UVLO_R}	UVLO release	V_{IN} rising	37	38.5	40 ⁽¹⁾	V
V_{UVLO_F}	UVLO lock-out	V_{IN} falling	30 ⁽¹⁾	31.5	33.5	V
	UVLO hysteresis			7.0		V
Hot swap MOSFET						
R_{DSON}	MOSFET resistance			0.5	1 ⁽¹⁾	Ω
	Default in-rush current limit	$V_{IN} > 30\text{ V}$	120 ⁽¹⁾	140	160 ⁽¹⁾	mA
	Default in-rush current limit	$15\text{ V} < V_{IN} < 30\text{ V}$	220 ⁽¹⁾	250	280 ⁽¹⁾	mA
	Default in-rush current limit	$1.5\text{ V} < V_{IN} < 15\text{ V}$	390 ⁽¹⁾	440	490 ⁽¹⁾	mA
	Adjustable in-rush current limit	$R_{AUXI_IRL} = 82\text{ k}\Omega$	120 ⁽¹⁾	140	160 ⁽¹⁾	mA
	Default DC current limit		390 ⁽¹⁾	440	490 ⁽¹⁾	mA
	Adjustable DC current limit precision	$R_{DCLL} = \text{From } 15.4\text{ k}\Omega \text{ to } 82\text{ k}\Omega$	-15 ⁽¹⁾	-	+15 ⁽¹⁾	%

Table 5. Electrical characteristics - interface section (continued)(V_{IN} = 48 V, VCC = open, T_A = 25 °C unless otherwise specified).

Symbol	Parameter	Test conditions	Min	Typ	Max	Unit
Power good indication						
	Hot-swap V _{DS}	V _{DS} falling	1.45 ⁽¹⁾	1.60	1.75 ⁽¹⁾	V
	Hysteresis			1.45		V
	Hot-swap V _{GS} required for power good	Guaranteed by design		2		V
nPGD	nPGD current source		25 ⁽¹⁾	30	35	μA
	nPGD pull down resistance	nPGD low; I = -5 mA			0.5 ⁽¹⁾	V
	nPGD threshold	nPGD rising	1.7 ⁽¹⁾	2	2.3 ⁽¹⁾	V
Auxiliary power						
AUX I	AUXI_IRL UVLO release	VIN rising	15 ⁽¹⁾	16	17 ⁽¹⁾	V
	AUXI_IRL UVLO lock-out	VIN falling	11.5 ⁽¹⁾	12.5	13.5 ⁽¹⁾	V
	AUXI / IRL switch-over threshold	V _{AUXI_IRL} rising		2		V
AUX II	Bias voltage	I _{AUXII} = 0 to -250 μA	0.85	1.1	1.4	V
	Lower threshold current		20	35	50	μA
	Upper threshold current		80	100	120	μA

Table 6. Electrical characteristics - SMPS section(V_{IN} = 48 V, VCC = open, T_A = 25 °C unless otherwise specified).

Symbol	Parameter	Test conditions	Min	Typ	Max	Unit
Oscillator						
f _{osc}	Free running	R _T = open	85 ⁽¹⁾	100	115 ⁽¹⁾	kHz
	Frequency programmability	R _T = 88 kΩ	210 ⁽¹⁾	240	270 ⁽¹⁾	kHz
		R _T = 33 kΩ	385 ⁽¹⁾	440	495 ⁽¹⁾	kHz
	Ext. synch threshold	50 ns pulse		2.8		V
Error amplifier						
V _{EA}	EA input voltage	FB = COMP	1.21 ⁽¹⁾	1.25	1.29 ⁽¹⁾	V
GBW	Gain bandwidth	Guaranteed by design		10		MHz
G ₀	DC gain	Guaranteed by design		75		dB
COMP	Sink current capability	COMP to GND	-8 ⁽¹⁾	-15		mA
Soft start						
I _{SS}	Soft start current	Charging	7 ⁽¹⁾	10	13 ⁽¹⁾	μA
		Discharging	-7 ⁽¹⁾	-10	-13 ⁽¹⁾	μA
	SS voltage	After soft start	2.1 ⁽¹⁾	2.3	2.5 ⁽¹⁾	V
Current limit						
	Delay to output	Guaranteed by design		20		ns
	Cycle by cycle current limit threshold voltage		0.44 ⁽¹⁾	0.50	0.56 ⁽¹⁾	V
	Leading edge blanking time			80		ns
PWM comparator						
	Delay to output	Guaranteed by design		25		ns
	Minimum duty cycle				0 ⁽¹⁾	%
	Maximum duty cycle			80	83 ⁽¹⁾	%
	COMP to PWM gain	Guaranteed by design		0.5		
Output driver						
	Output high	I _{GD} = 100 mA; guaranteed by design		V _{CC} -0.4	V _{CC} -0.7	V
	Output low	I _{GD} = -100 mA		0.25	0.5	V
	Fall time	C _{LOAD} = 3.3 nF		35		ns
	Rise time	C _{LOAD} = 3.3 nF		35		ns
	Peak source current	C _{LOAD} = 3.3 nF; guaranteed by design		800		mA

Table 6. Electrical characteristics - SMPS section(V_{IN} = 48 V, V_{CC} = open, T_A = 25 °C unless otherwise specified).

Symbol	Parameter	Test conditions	Min	Typ	Max	Unit
	Peak sink current	C _{LOAD} = 3.3 nF; Guaranteed by design		1200		mA
Thermal shutdown						
	Shutdown temp.	1 st level; Inrush phase only; Guaranteed by design		130		°C
		2 nd Level; guaranteed by design		160		°C
	Th. shutdown Hyst.			30		°C
VCC regulation						
VCC	Internal default	V _{IN} = 48 V; V _{CC} = open	8 ⁽¹⁾	8.3	8.6 ⁽¹⁾	V
	Current capability	V _{IN} = 48 V; GD = open			10 ⁽¹⁾	mA
V _{CCUVLO}	Internal default UVLO, release	V _{CC} rising; wrt VCC	-400 ⁽¹⁾		-50	mV
	Internal default; UVLO, lock-out	V _{CC} falling	6.4 ⁽¹⁾	6.7	7.1 ⁽¹⁾	V
ICC	V _{CC} supply current	V _{CC} = 10 V		4		mA
	V _{CC} regulator dropout	ICC = 5 mA; GD = open		2		V

- Note: 1 These values applies over the full operating temperature range.
2 Device thermal limitations could limit useful operating range.
3 The V_{CC} regulator is intended for internal use only as bias supply of PM8800A; any additional external V_{CC} current has to be limited within the specified max current limit.

4 Device description and operation

The PM8800A is a monolithic device embedding an IEEE 802.3af compliant PD interface together with a current mode pulse width modulator to be used in all power over Ethernet powered devices.

In addition to the standard.3af features, PM8800A anticipates some features of the forthcoming.3at standard, specifically targeting appliances or systems requiring higher power with respect to the 12.95 W allowed by standard PSE.

The PD interface integrates the 24.5 kΩ signature resistor used in detection and disabled during the rest of operating modes. Classification is done through an external resistor detached when classification is over, in order to save power.

The PM8800A integrates standard compliant UVLO thresholds to determine normal operating mode (UVLO rising) or recognize disconnection (UVLO falling).

A graphical representation of the voltage thresholds and hysteresis during all the operating phases is depicted in the following figure:

Figure 6. State diagram of the PM8800A interface depending on the input voltage

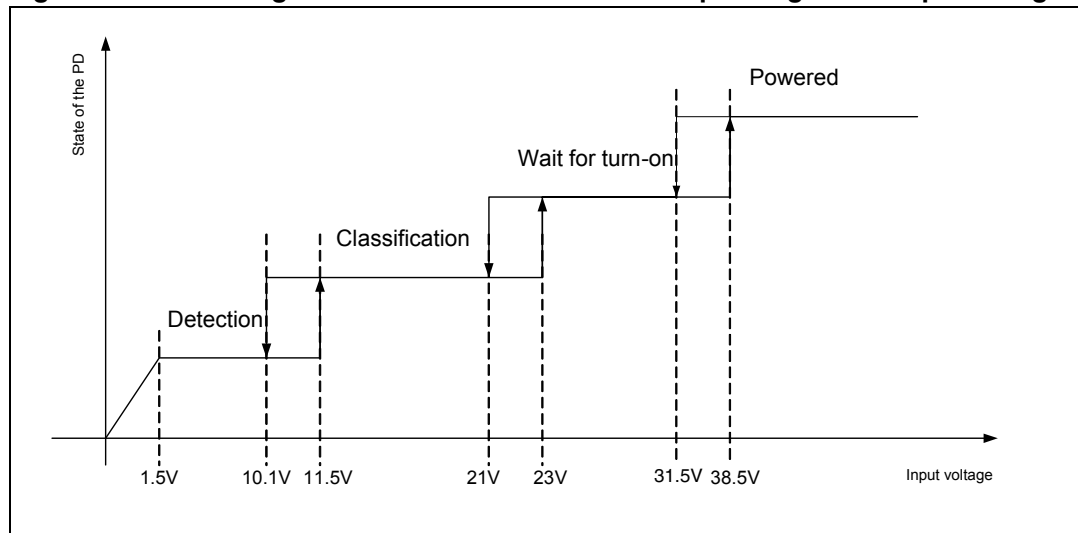

For input voltages in the range 1.5 to 11.5 V, PM8800A exposes a 24.5 kΩ resistance. After detection is over, the internal resistor is disabled and the external classification resistor is presented. When classification is over, the external resistor is disconnected and the PM8800A wait for the input voltage to overpass the UVLO voltage.

The hot-swap MOSFET is specifically designed to have a low R_{DSon} to contain the conduction losses and sustain up to 800 mA. A constant dissipated power method is used to limit the current in the in-rush phase. The integrated in-rush current limit controls in a safe manner the current flowing through the MOSFET, shortening the duration of the hot-swap event itself. Designers have the possibility to further limit the current in the in-rush by acting on the proper programming resistor.

Designers have the possibility to set the limit of the current through the interface during normal operation. For non standard application, this limit exceeds the 350 mA foreseen by the 802.3af and can reach up to 800 mA.

PM8800A can work with power either from PoE networks or from auxiliary sources - like AC adapters -. Alternative sources are present in PoE appliances where devices can work also outside the context of the PoE networks or to ensure normal operation even if PoE becomes unavailable. PM8800A limits the number of external components to handle the coexistence of both PoE and auxiliary supplies.

External sources can be connected so to exploit the in-rush current limitation provided by the MOSFET or enabling the PWM section, bypassing the interface section.

A state-of-the-art current mode pulse with modulator is embedded in the PM8800A to support low side single ended isolated and non isolated topologies. A high gain bandwidth product error amplifier is embedded for non isolated configuration.

PM8800A has a 80 % maximum duty cycle, featuring embedded slope compensation.

The PWM switching frequency of PM8800A is programmable with an appropriate resistor and it is also capable of working with an external clock reference.

5 PD interface

5.1 Detection

In power over Ethernet systems, the PSE senses the connection to detect whether an IEEE 802.3af compatible device is plugged to the cable termination by applying a small voltage (2.7 to 10 V) on the Ethernet cable and measuring in two successive steps the equivalent resistance. During this phase, the Powered Device must present a resistance between 23.75 kΩ and 26.25 kΩ

PM8800A integrates a 24.5 kΩ signature resistor to simplify the design of PoE powered Device appliances and to reduce the overall component count.

Signature resistor is in series to a pass transistor (see [Figure 7](#)) used to disconnect the resistor itself upon completion of the detection phase.

The value of the integrated detection resistance has been selected taking into account also the diode bridges typical voltage drop.

During detection, most of the circuits inside the PM8800A are disabled to minimize the offset current.

Figure 7. PM8800A: reference schematic of the integrated 24.5 kΩ and resistor disable logic

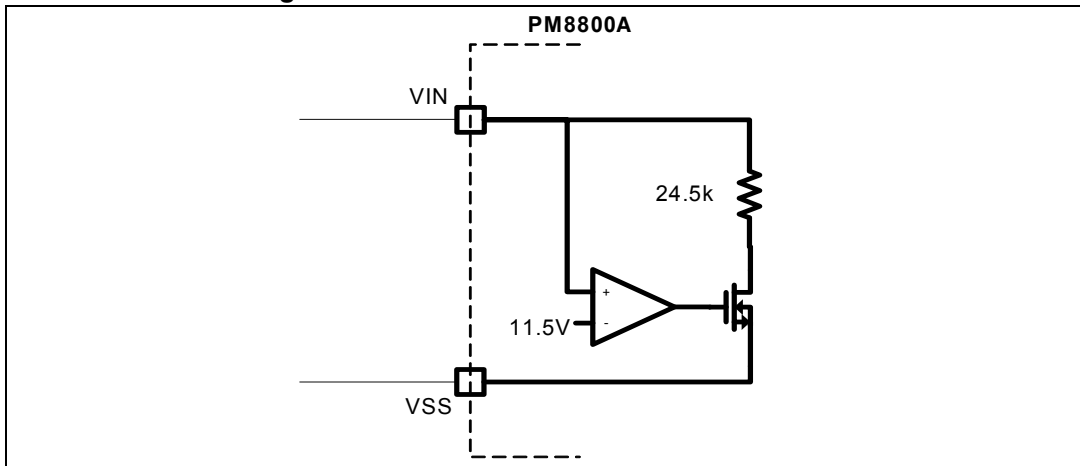

5.2 Classification

Classification process in the IEEE 802.3af standard is optional for the powered device. This feature allows PSE to plan and allocate the available power to the appliances connected to the PoE network. IEEE 802.3af specification groups the need for power of the PD in 5 classes, one is reserved for future use. After successful detection, the PSE sets a constant voltage between 15.5 V and 20.5 V for a maximum duration of 75 ms and senses the current flowing through the cable to determine the PD's class.

The relevant thresholds in PM8800A are 11.5 V and 23 V, with a turn off hysteresis of 1.4 V.

To support the classification function, an equivalent programmable constant current generator has been implemented. The following figure depicts a principle schematic of the classification circuit. Just after the detection phase has been successfully completed, the voltage of the RCLASS pin is set to the 1.4 V voltage reference and a pass transistor connects the VIN pin to RCLASS pin.

Figure 8. PM8800A: reference schematic of the PoE classification logic

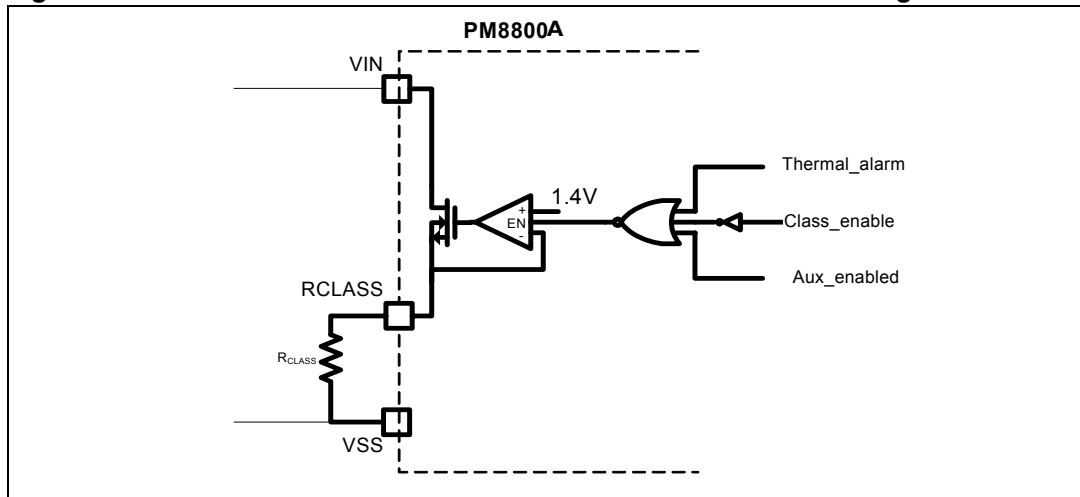

Classification resistor can be detached by three main causes:

- An auxiliary power source (front or rear) has been connected (see [Section 7](#)),
- The device is in thermal protection
- The classification has been successfully completed.

Designers can set the current by changing the value of the external resistor according to the following table.

Table 7. value of the external classification resistor for the different PD class of power

CLASS	PD power (W)	R _{CLASS} (Ω)	IEEE 802.3af Classification current (mA)	
			min	max
0	0.44 - 12.95	Open	0	4
1	0.44 - 3.84	158	9	12
2	3.84 - 6.49	82.5	17	20
3	6.49 - 12.95	52.3	26	30
4	Reserved	36.5	36	44

5.3 Under voltage lock-out

After the classification is completed, the PSE raises the voltage to provide the Power Devices with the negotiated power. During the transition from low to operating voltage, the internal UVLO is released and the hot-swap MOSFET is activated initiating the in-rush sequence.

The IEEE 802.3af standard sets a maximum turn-on voltage (42 V) and the minimum turn-off voltage (30 V) for the PDs and indicates normal voltage drops across the Ethernet cable.

The PM8800A implements the UVLO mechanism by setting 2 internal thresholds on the voltage across the VIN-VSS pins; one is to activate the hot-swap (V_{UVLO_R}), while the other is to switch off the hot-swap MOSFET upon detection of a supply voltage drop (V_{UVLO_F}) from normal operating conditions.

No additional external components are required to comply with the IEEE 802.3af requirements. Thermal protection alarm overrides the gate driving of the MOSFET immediately switching off the MOSFET itself in case of device overheating. The hot-swap is bypassed also in auxiliary source topology supplying directly the PWM and not requiring the hot-swap to be active.

5.4 In rush current limit

Once the detection and classification phases have been successfully completed, the PSE raises the voltage across the Ethernet cable. When the voltage difference between the VIN and VSS is greater than the V_{UVLO_R} threshold, the internal hot-swap MOSFET is switched on and the DC-DC input capacitance is charged in a controlled way.

As depicted in the following figure, the current delivered by the hot-swap MOSFET during inrush period is a function of the voltage drop between GND and VSS (hot-swap drain source terminals). In more detail, the higher the voltage across the internal hot-swap, the lower the current flowing through it, so that the total dissipated power is almost constant throughout the inrush phase, preventing the IC to reach the thermal protection limit.

The lower current limitation is internally set at 140 mA and takes action when the voltage GND-VSS is above 30 V. The second limit is set at 250 mA when GND-VSS voltage is between 30 V and 15 V. When the voltage falls below 15 V, the limit switches to the higher

inrush current level, which is set by default at 440 mA. Connecting a resistor between VSS and AUX_ IRL it's possible to adjust this limit to a lower value.

Figure 9. Relation between the hot-swap drain-source voltage and the default Inrush current.

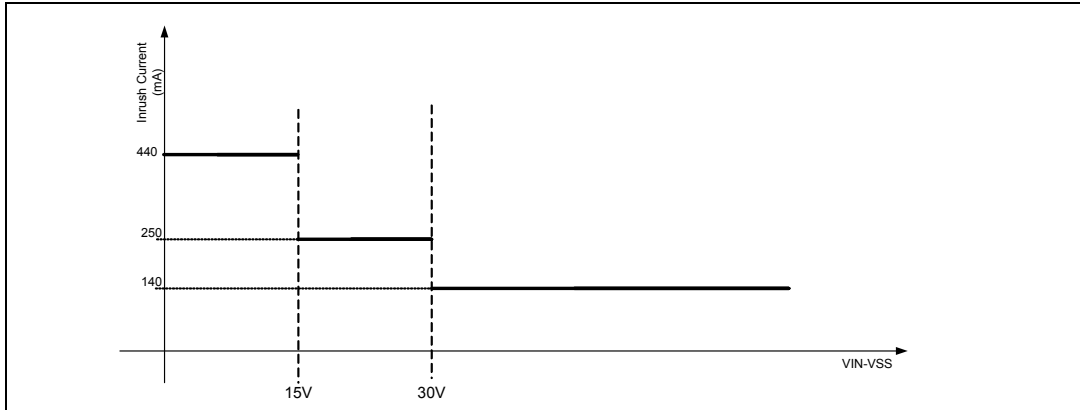

The maximum inrush current can be set by programming the value of the resistor on the AUX_ IRL pin. Depending on the chosen value there could be 3 steps (when the selected max current is between 250 and 400 mA), 2 steps (when the selected max current is between 140 and 250 mA) or a single step.

The formulae to select the desired inrush current is the following:

$$R_{IRL}[\text{k}\Omega] = \frac{11200}{I_{IRL}[\text{mA}]}$$

The PM8800A useful programming range for the inrush current limitation is between 140 mA and 440 mA. Practical resistor value ranges between 25 kΩ and 82 kΩ.

Figure 10. Inrush current limit vs R_{IRL}

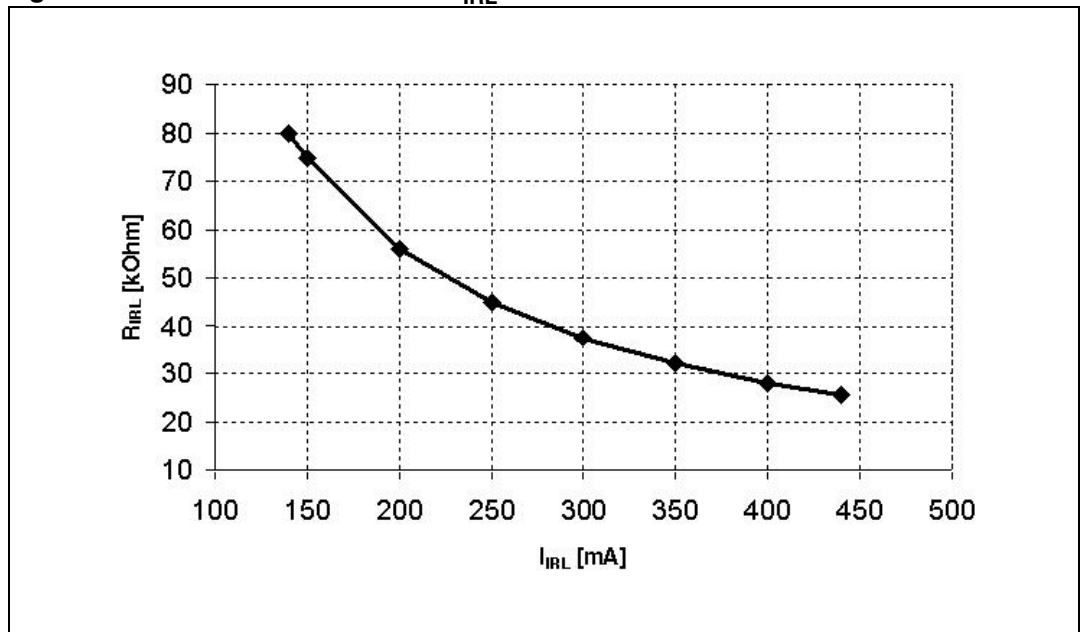

In the following picture a typical start sequence that can be observed in real circuits.

Figure 11. Typical start up sequence

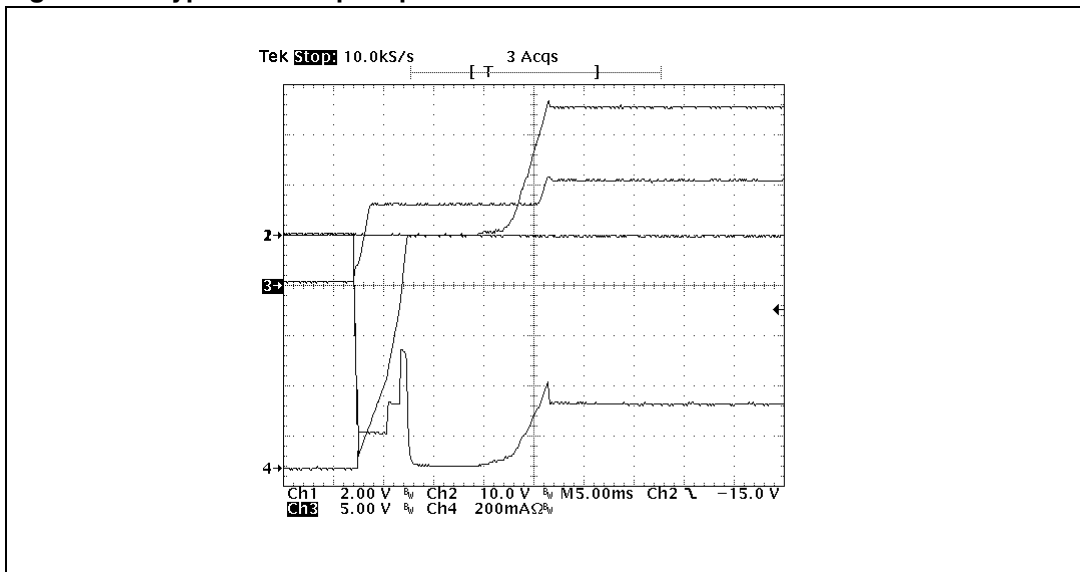

Ch1 = 5 Vout, Ch2 = VSS - GND, Ch3 = Vcc, Ch4 = I input

Depending on the application, care must be put on the choice of the inrush current limit to avoid that the voltage drop on the external Ethernet cable will cause UVLO conditions during the charging phase of the bulk capacitor.

It is recommended to select this voltage drop (20 Ω max for 100 m of cable x I inrush) to be lower than the UVLO hysteresis (7 V) in order to avoid hiccup turn on.

5.5 Continuous current limitation

PM8800A provide a default continuous current limitation of 440 mA. This is achieved by leaving the pin DCCDL floating. A different DC current limit can be set by connecting a resistor between DCCL and VSS whose value can be obtained by the following equation:

$$R_{DC}[k\Omega] = \frac{11200}{I_{DC}[mA]}$$

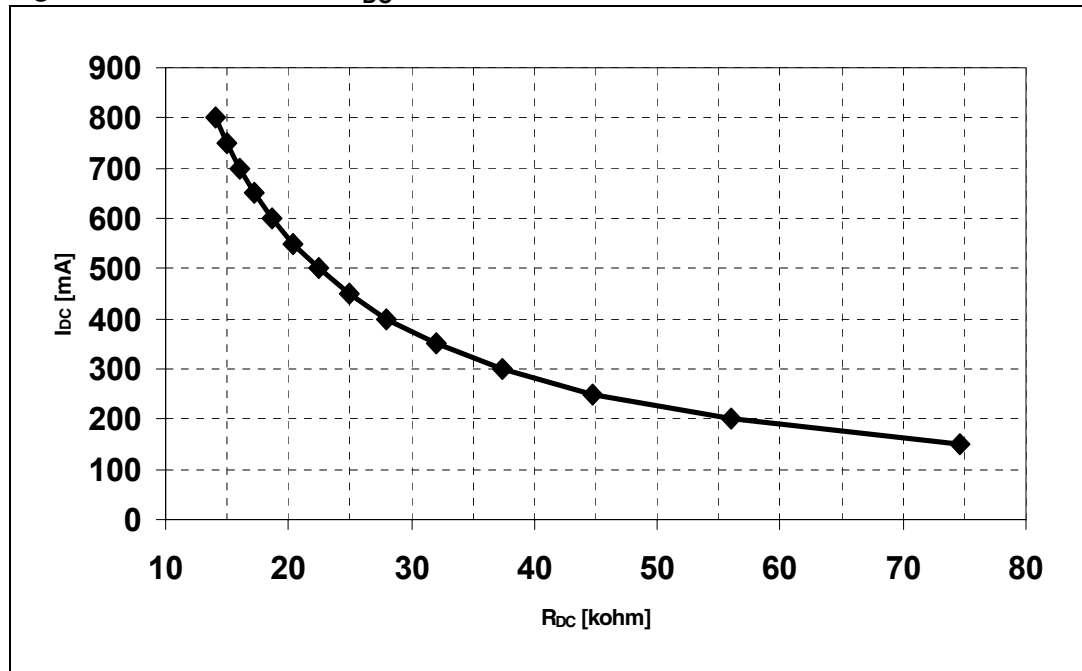
Figure 12. DC current vs R_{DC} 

This limitation is active after nPGD set and when the PD is supplied through the PoE or in the Front connection (see [Section 7](#))

The PM8800A useful programming range for the current limitation is between 150 mA and 800 mA. Practical resistor value ranges between 15 k Ω and 75 k Ω .

5.6 HV regulator startup

PM8800A embeds a high voltage start-up regulator to provide a controlled reference voltage of 8.3 V to the Current mode PWM during its start-up phase.

The regulator output is connected to the VCC pin as well as to the DC DC section

In normal isolated topology, the VCC pin is diode connected to the auxiliary winding of the transformer used for the flyback or forward configuration. When the voltage from the transformer exceeds the regulated voltage, the high voltage regulator is shut off, reducing the amount of power dissipated inside the PM8800A.

The external auxiliary voltage must higher then 8.3 V but must be also lower than 15 V under all working conditions, to avoid the intervent of the internal protection clamp.

A VCC UVLO mechanism monitors the level of voltage on the VCC pin. When VCC voltage exceeds the VCC_{UVLO_R} the PWM controller is enabled and it remains enabled until the VCC voltage drops under its VCC_{UVLO_F} value.

5.7 Power good indication

The PM8800A embeds a power good circuit that is used to indicate that PWM input capacitors are fully charged and that the switching regulator can start operation. The power good circuit monitors the status of the internal hot-swap MOSFET and nPGD, an active low signal is asserted when its V_{DS} voltage falls below 1.5 V and V_{GS} rise above 2 V. The power good circuit includes hysteresis to allow the PM8800A to operate near the current limit point without inadvertently disabling nPGD. The MOSFET voltage must increase to 3 V before nPGD is disabled.

An internal comparator monitors the status of the nPGD pin and the PWM controller will be running until the voltage at this pin goes above 2 V.

The power good indication is exposed at nPGD pin with a open drain, 45 Ω MOSFET so that board designers can put a LED and a series current limiting resistor from the VCC pin to the nPGD pin to indicate that the PD is powered from the PoE network.

Since the power good signal is internally used to activate the PWM controller, to avoid that transients on the input voltage could produce intermittent operation of the PWM controller, board designer can connect a capacitor C_{PGD} between the nPGD pin and GND. This will mask the nPGD signal for a duration that can be estimate by the following equation:

$$\Delta t(\mu s) = \frac{(2V \cdot C_{PGD}(nF))}{(0.03mA + I_{LED}(mA))}$$

where 30 μA is an internal current source that act as pull-up on the nPGD pin and I_{LED} is the current flowing through the external LED, if present.

6 PWM section

6.1 Error amplifier and loop compensation

The PM8800A addresses both isolated and non-isolated configuration by embedding a wide band high gain error amplifier.

In non-isolated topology, the voltage to be regulated is connected to the FB pin - the inverting input of the EA - through a resistor divider. The non inverting input of the EA is set to a fixed reference value of 1.25 V. The output of the error amplifier is connected to the COMP pin which is pulled up internally with a 2.5 kΩ resistor to a fixed reference of 3.3 V; loop compensation can be done connecting an appropriate compensation network between the FB pin and the COMP pin

Figure 13. Non-isolated feedback

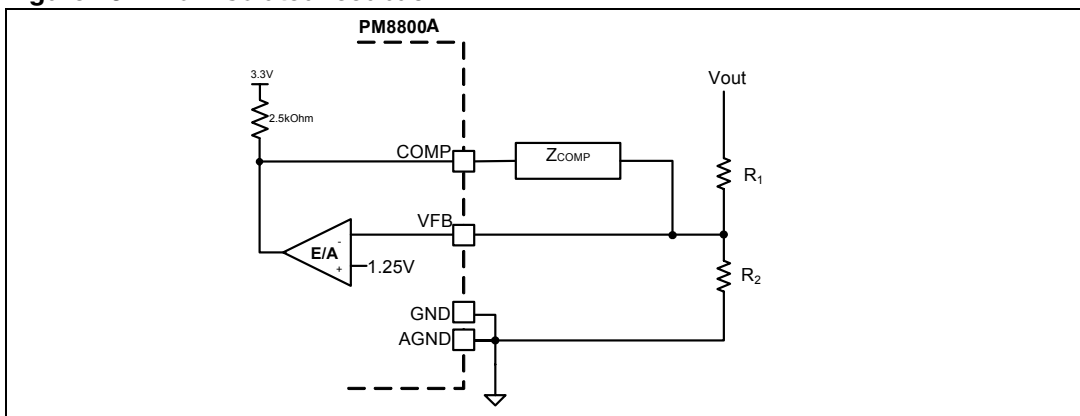

In typical isolated topology, the error amplifier is located outside the IC and the feedback signal is taken on the collector of an opto coupler. The internal error amplifier is to be bypassed connecting the FB pin to AGND. In order to minimize external components count the opto coupler is directly connected to the COMP pin using the internal pull-up resistor as bias for the opto coupler.

Figure 14. Isolated opto coupler feedback.

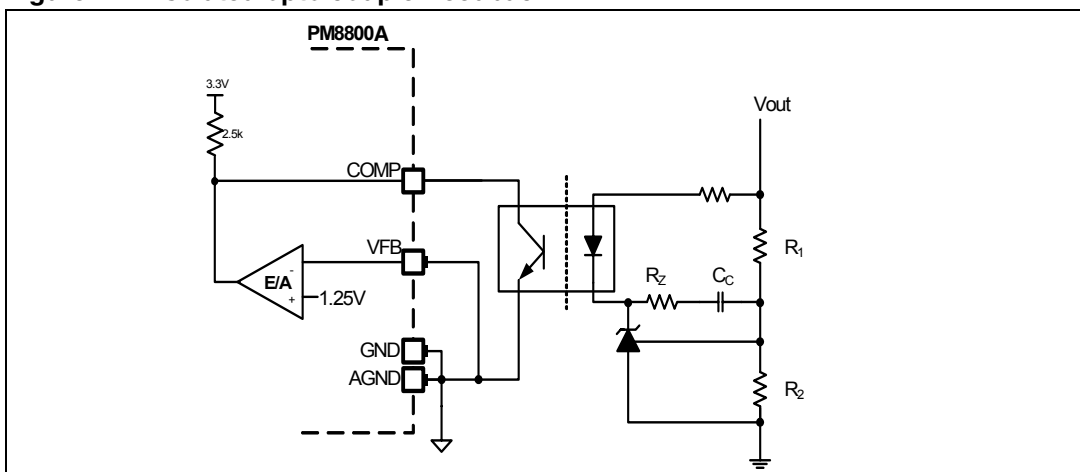

When a shunt regulator is used for output voltage regulation, the output voltage is set by the ratio of resistors R1 and R2, see [Figure 14](#) for details. The output voltage is given by the following equation:

$$V_{out} = V_{REF} \cdot \left(1 + \frac{R_2}{R_1}\right)$$

where V_{REF} is the reference voltage of the shunt regulator chosen for the application.

Loop compensation in typical isolated application is done by connecting an appropriate compensation network around the external error amplifier.

A pull-up current source of few nA is internally connected to FB pin providing a safe switch-off of the DC DC converter in case of feedback disconnection.

6.2 Oscillator and sync capability

The internal oscillator frequency can be programmed by connecting an external resistor between the RT and AGND pins. The relation between the oscillator frequency f_{OSC} and the R_T resistor is:

$$f_{osc}(\text{kHz}) = 100 \cdot \left(1 + \frac{125}{3\text{k}\Omega + R_T(\text{k}\Omega)}\right)$$

Figure 15. PWM frequency vs R_T

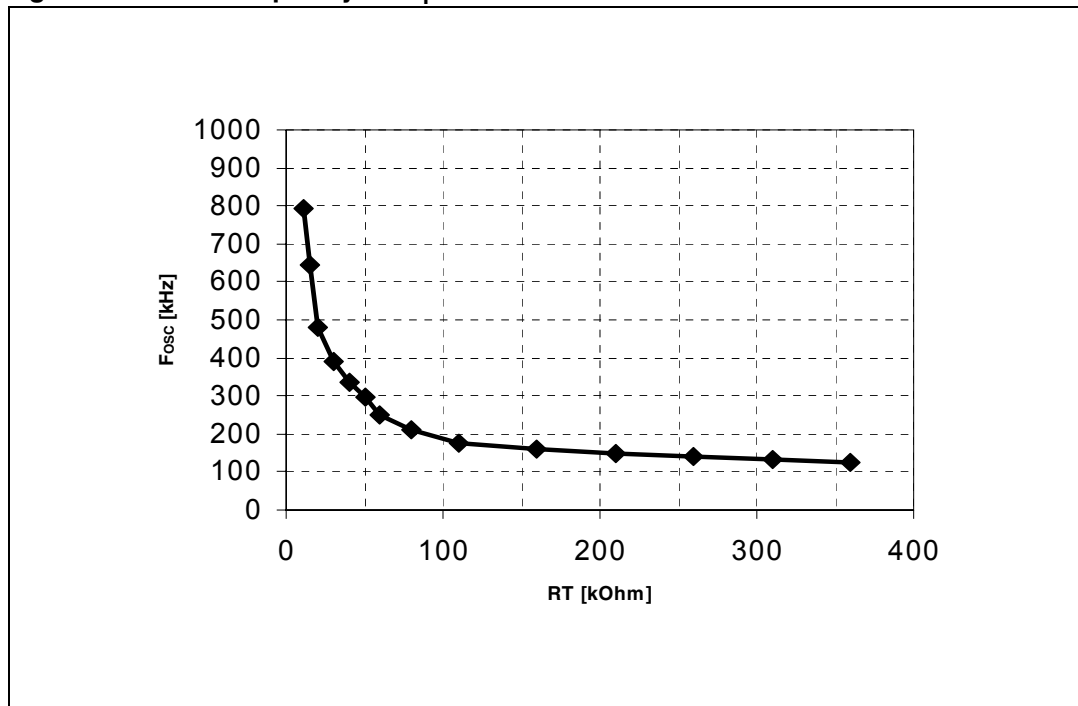

The PWM switching frequency is equal to the programmed oscillator frequency.

The PM8800A can work also with a clock reference provided by an external source whose frequency is higher than the one programmed by the R_T resistor. The presence of the external resistor is mandatory also when the reference is provided from outside the IC.

The external source must be coupled to the R_T with a 100 pF capacitor and have a minimum peak amplitude of 2.8 V. Minimum pulse width of 50 ns has to be assured for proper operation.

When synchronized the PWM frequency is equal to the external clock reference.

6.3 Soft start

The soft-start feature of the PM8800A allows the load voltage to ramp-up in a safe and controlled manner. This is achieved by a 10 μ A internal current source charging an external C_{SS} capacitor connected to the SS pin, which progressively increases the duty cycle of the PWM pulse, since the reference of the error amplifier is clamped with this value. Duration of the start-up time and external capacitor are linked by the following relation:

$$t_{ss}(ms) = 0.23 \cdot C_{SS}(nF)$$

SS voltage is actively kept at 2.3 V by the internal control circuitry, which manages also over-current and fault conditions.

Figure 16. Typical soft start waveform

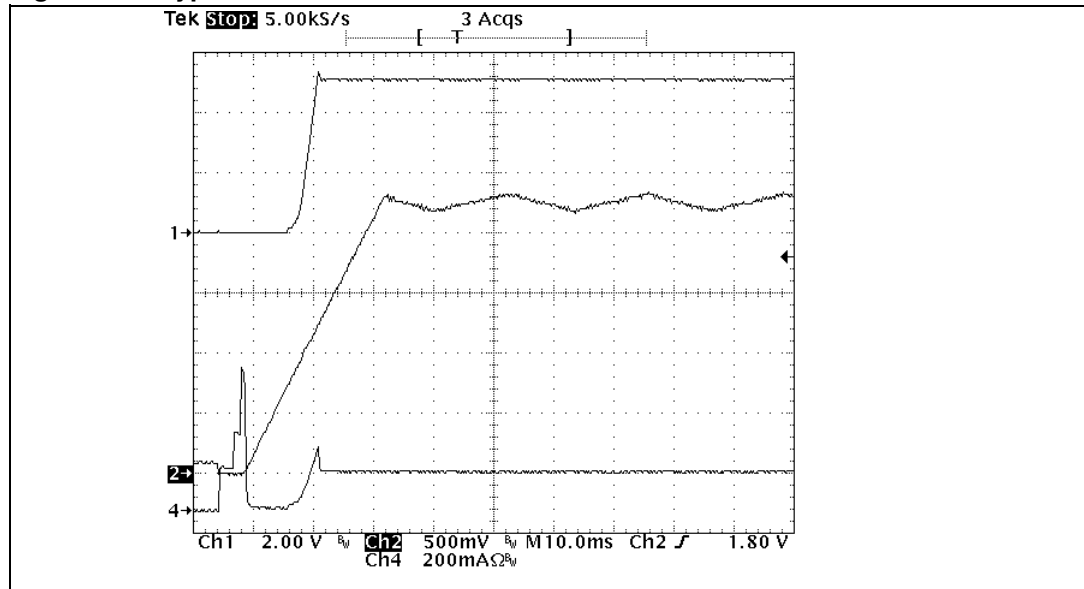

Ch1 = 5Vout, Ch2 = soft start, Ch4 = I input

6.4 PWM comparator / slope compensation

In typical isolated operation, current is sensed on a sense resistor R_s put between the source of the primary side MOSFET and GND pin, while for non-isolated topology it is often sensed on a proper resistor put on the source of a low-side MOSFET.

The PWM comparator produces the PWM duty cycle by comparing the R_s ramp signal on CS with an error voltage derived from the error amplifier output.

The error amplifier output voltage at the COMP pin is offset by 0.7 V and then further attenuated by a 2:1 resistor divider before it is presented to the PWM comparator input.

The PWM duty cycle increases with the voltage at the COMP pin. The controller output duty cycle reduces to zero when the COMP pin voltage drops below approximately 0.7 V.

For duty cycles greater than 50 %, current mode control loops are subject to sub-harmonic oscillation. The PM8800A fixes the maximum duty cycle at 80 % and implements a slope compensation technique consisting on adding an additional fixed slope voltage ramp to the signal at the CS pin. This is achieved by injecting a 45 μA sawtooth current into the current sense signal path on an integrated 2 k Ω resistor.

Additional slope compensation may be added by increasing the source impedance of the current sense signal with an external resistor between the CS pin and the source of the current sense signal. The net effect in this case is to increase the slope of the voltage ramp at the PWM comparator terminals.

6.5 Current limiting

The current sensed through the CS pin is compared to two fixed levels of 0.5 V and 0.7 V.

The lower level is used to perform a cycle-by-cycle current limit, terminating the PWM pulse. In case of recurring overload a timing structure is activated through SS pin, sourcing a small current of about 1 μA on SS capacitor. The voltage on SS rises whenever during a PWM cycle an over current event occurs, while decreases to the default voltage (2.3 V) if it does not.

If SS voltage reaches 2.8 V, a slow hiccup is performed sinking 1 μA from SS, and shutting down the gate driver until the SS capacitor is fully discharged.

Then a new soft-start procedure is performed.

Figure 17. Short circuit on the output

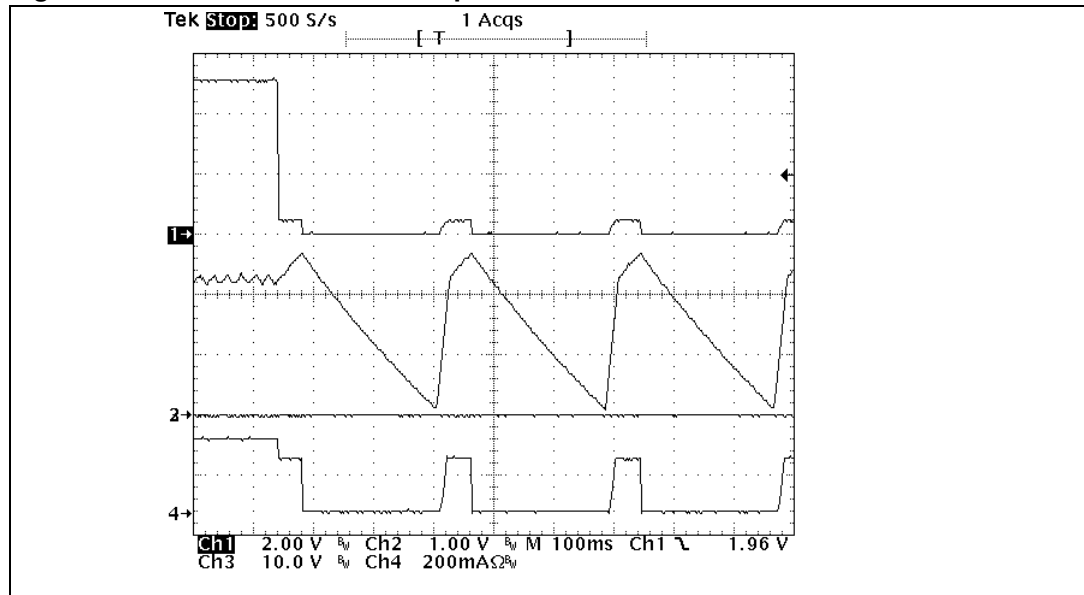

Ch1 = 5Vout, Ch2 = SoftStart, Ch3 = VSS - GND, Ch4 = I input

When a severe over current occurs, like a short circuit of an internal power component, and 0.7 V level is reached on CS, the gate driver is instantaneously shut down and a fast hiccup cycle is performed. When the 10 μ A sink current fully discharges the SS capacitor, a new soft-start procedure is performed.

In case of persistent severe over current, the control logic tries 4 cycles of fast hiccup before shutting down the PWM controller at all.

To restart the device, after removing the cause of over current, VIN must be lowered under UVLO level.

Figure 18. Internal short circuit

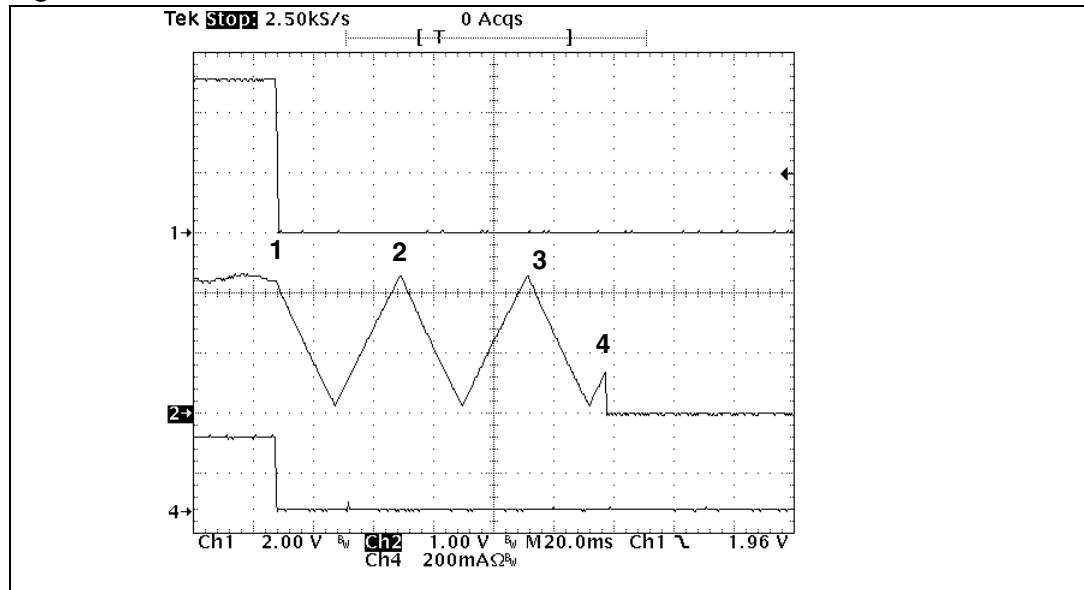

Ch1 = 5 Vout, Ch2 = SoftStart, Ch4= I input

6.6 Leading edge blanking

The sense current waveform often observes large spikes on the leading edge. This is due to rectifier recovery and/or interwinding capacitance in the power transformer. If not attenuated, this transient can prematurely terminate the output pulse. A simple RC filter - whose time constant is approximately equal to the spike duration - is usually adequate to suppress this spike.

An internal blanking time has been anyway integrated in order to prevent false overcurrent detection to terminate the PWM waveform. This is done by a masking logic, active for duration of 70 ns after the turn-on time of the primary side MOSFET.

6.7 Thermal protection

PM8800A has a two level thermal protection referred to the internal junction temperature.

First limit is set to 130 °C and limits the current into the hot-swap MOSFET to 140 mA every time the voltage difference between VSS and GND is higher than 3 V.

The second limit is set to 160 °C and is always active. When this threshold is overtaken, the hot-swap is opened and the PWM controller is switched-off.

7 Auxiliary sources

The majority of powered devices is designed to work with power from either PoE network or auxiliary sources. Even though having both sources simultaneously connected is not the normal operating case, the presence of an auxiliary supply allows PDs to be used also when the PoE is not available or not sufficient. This is particularly true for appliances requiring more than 12.95 W connected to 802.3af compliant PSE.

High degree of flexibility is granted by the PM8800A for designs based on external sources.

As depicted in the following figure there are two available options for connecting auxiliary sources to the PM8800A. One possibility consists in diode O-ring the auxiliary source into the PM8800A PoE pins (VIN and VSS) referred to "Option I". In the second alternative, referred to "Option II" the external supply voltage is diode ORed into the PWM section of the device.

Figure 19. Alternatives for auxiliary source connection

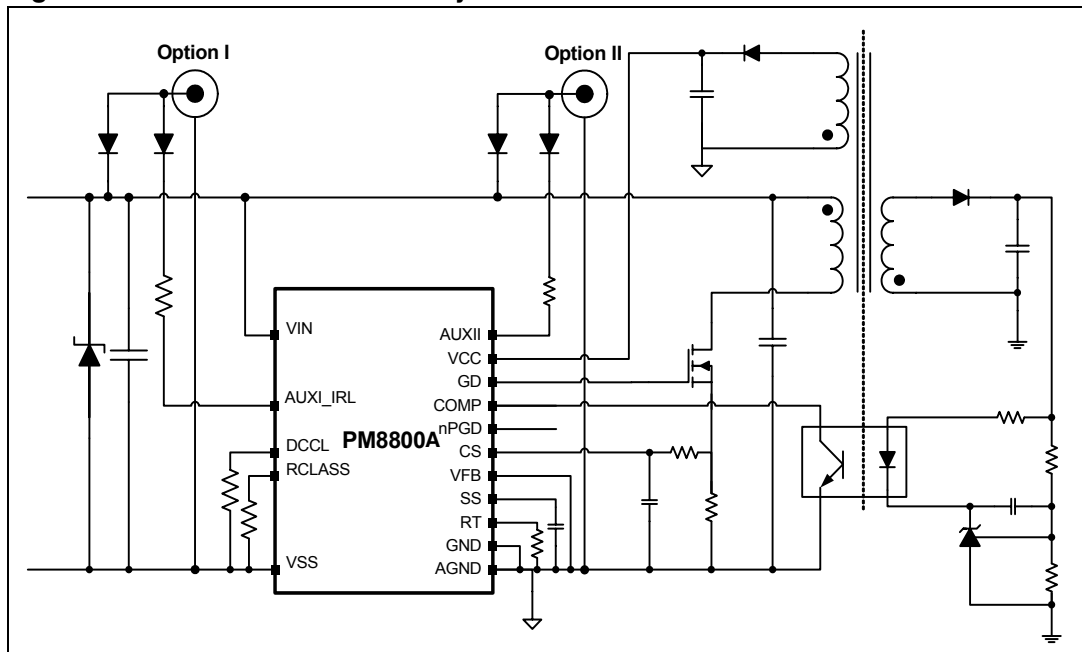

The two options differ for the in-rush and DC current protection, for the allowed auxiliary source voltage range, power sequence and prevalence of the external source with respect to the PoE one.

Option I configuration has been designed to take advantage of the inherent in-rush and DC current protection also when working with voltages from external power supplies.

When the auxiliary source is connected prior to PD detection by the PSE and has a voltage above the V_{UVLO_R} (38-57 V), the internal UVLO is released and the MOSFET is switched on, starting the inrush phase. Inrush and DC current limit can be programmed by respective external resistors see [Section 5.4](#) and [Section 5.5](#).

Internal under voltage lock out threshold can be lowered by connecting the auxiliary source to the AUXI_IRL pin. Wall adapter with supply voltage lower than 38 V can be used, still profiting from the inrush and DC current limit provided by the hot-swap MOSFET.

The minimum external voltage to be used in this configuration is about 16 V.

Option I connection is activated when the voltage at the relevant pin is higher than 2 V and a current I_{AUXI} higher than 70 μA is forced into the pin.

$$I_{AUXI} = \frac{V_{AUXI} - V_D - 2}{R_{AUXI}} \geq 70 \mu\text{A}$$

The AUXI_IRL pin can be connected to the auxiliary source through a diode being the current internally limited to about 300 μA .

It is important to highlight that UVLO override and inrush current limit are mutually exclusive, and when UVLO is overridden, default inrush current limit is provided. The PSE will not detect the presence of a valid PD, since the PoE diode bridges are reversed biased.

When the auxiliary source is connected after the inrush phase, two possibilities arise depending on the voltage of the external power supply. If the voltage is lower than the one from PoE, the diode is reverse biased and PSE will keep on supplying the PD. If the auxiliary source has a voltage greater than the PoE, the PoE diode bridge will be reverse biased and auxiliary source will supply the PD. In case the voltages are comparable, current sharing occurs between the sources according to their respective source resistance.

The **Option II** configuration bypasses the PD interface and connects directly the external source to the PWM section. This type of connection is not limited by the internal current limit circuits and therefore is more suitable for lower auxiliary voltages.

Internal under voltage lock out threshold will be lowered by connecting the auxiliary source to the AUXII pin. The minimum external voltage to be used in this configuration is about 12 V.

Note that inrush current in this case is not limited and an external solution must be found: the simplest solution is to put a low value resistor in series, but this lower the converter efficiency. More efficient solution is the use of a MOSFET as power switch, able to limit the current during the charging phase, and to add only few milliohm in series during normal operation.

Main advantage of this connection is the "prevalence" over PoE voltage, that can be obtained pulling up AUXII pin with a R_{AUXII} resistor and forcing a current into the pin greater than 100 μA (see following equation). In this case the PD interface is switched off regardless the presence of PoE voltage.

$$I_{AUXII} = \frac{V_{AUXII} - V_D - 1.1}{R_{AUXII}} \geq 100 \mu\text{A}$$

AUXII can be connected directly to the auxiliary voltage through a diode. The current in this case is internally limited to about 250 μA .

If a prevalent AUXII is detected the PD interface is switched off, the hot swap MOSFET is opened regardless the PoE voltage level.

If the current forced into AUXII pin is lower than 60 μ A, the internal under voltage lock out threshold will be lowered but AUXII connection will be not prevalent to the PoE; in this case power to the DC/DC converter will be drawn from the source that has been applied first.

In case of very low auxiliary voltage (i.e. lower than 15 V) is recommended to supply VCC directly with the auxiliary voltage through a bypass diode, in order to assure a proper operation of the pwm section of PM8800A.

Figure 20. Switch over between 48 V PoE and 12 V AUXII auxiliary adapter

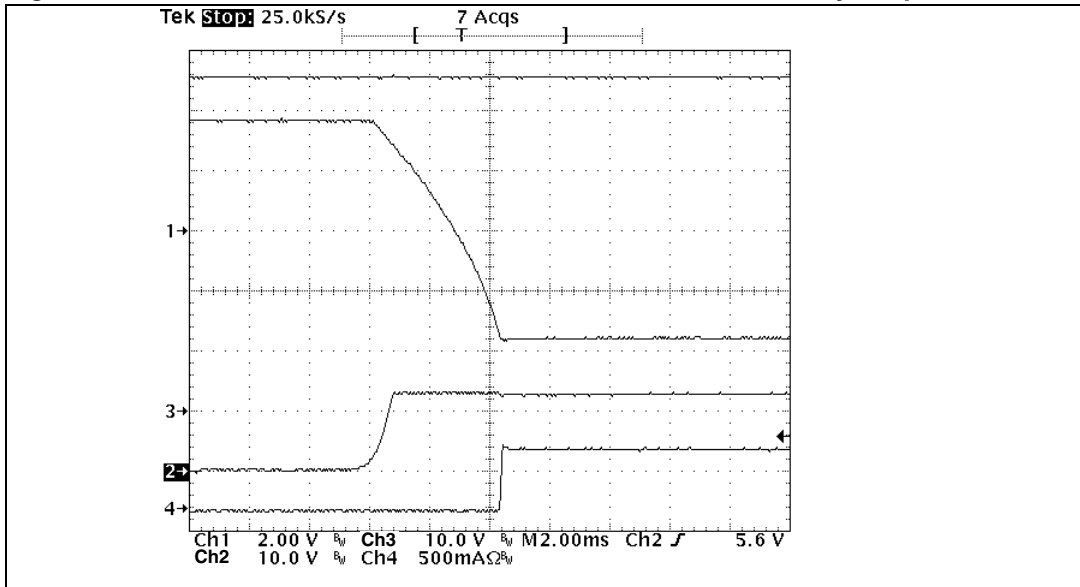

Ch1 = 5 Vout, Ch2 = Aux voltage, Ch3 = internal primary voltage, Ch4 = Aux input current

8 Package mechanical data

In order to meet environmental requirements, ST offers these devices in ECOPACK® packages. These packages have a lead-free second level interconnect. The category of second Level Interconnect is marked on the package and on the inner box label, in compliance with JEDEC Standard JESD97. The maximum ratings related to soldering conditions are also marked on the inner box label. ECOPACK is an ST trademark. ECOPACK specifications are available at: www.st.com.

8.1 HTSSOP16 mechanical data

Figure 21. HTSSOP16 mechanical data and package dimensions

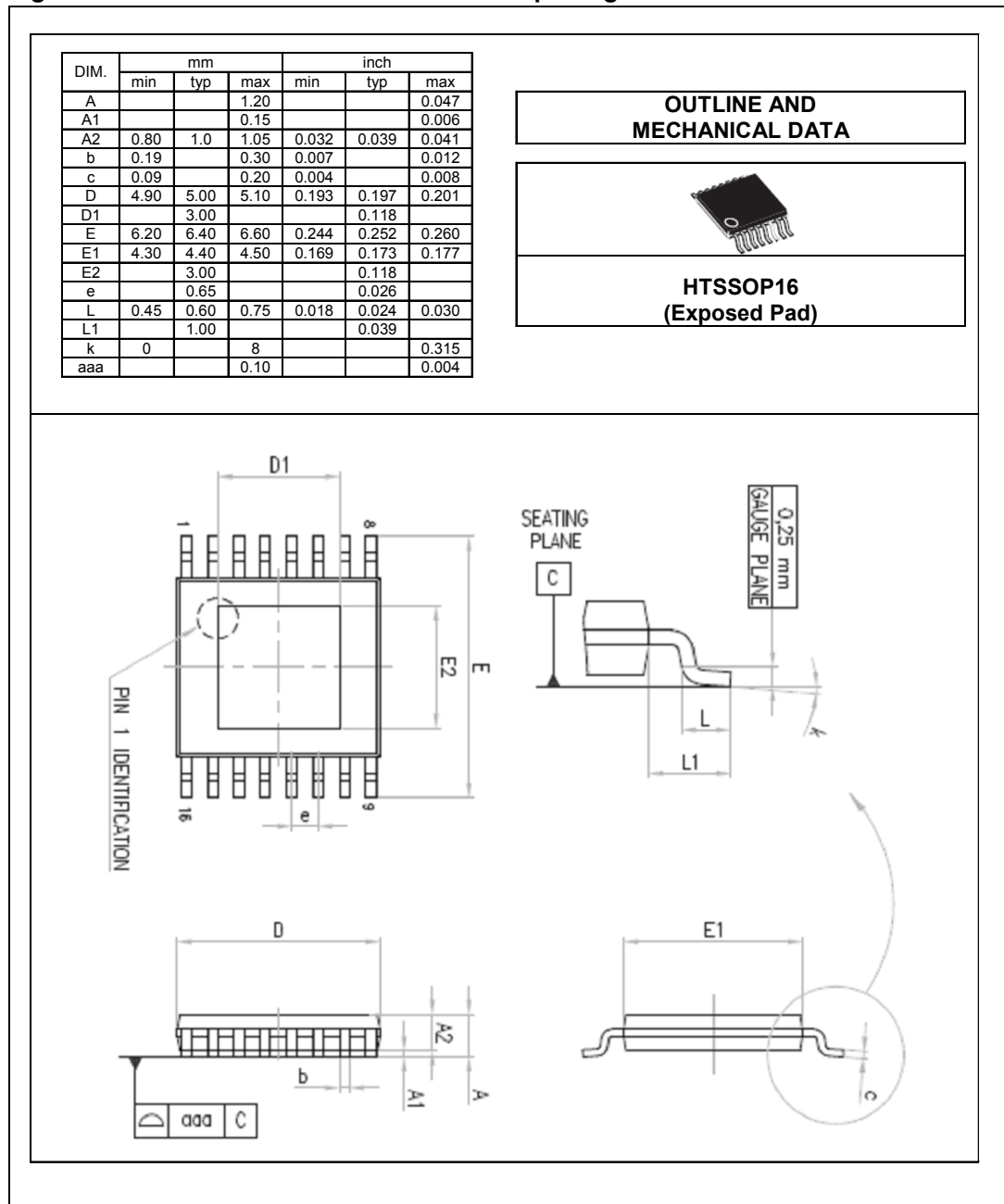

9 Revision history

Table 8. Document revision history

Date	Revision	Changes
17-Sep-2007	1	Initial release
20-Feb-2008	2	Content reworked in order to improve readability

Please Read Carefully:

Information in this document is provided solely in connection with ST products. STMicroelectronics NV and its subsidiaries ("ST") reserve the right to make changes, corrections, modifications or improvements, to this document, and the products and services described herein at any time, without notice.

All ST products are sold pursuant to ST's terms and conditions of sale.

Purchasers are solely responsible for the choice, selection and use of the ST products and services described herein, and ST assumes no liability whatsoever relating to the choice, selection or use of the ST products and services described herein.

No license, express or implied, by estoppel or otherwise, to any intellectual property rights is granted under this document. If any part of this document refers to any third party products or services it shall not be deemed a license grant by ST for the use of such third party products or services, or any intellectual property contained therein or considered as a warranty covering the use in any manner whatsoever of such third party products or services or any intellectual property contained therein.

UNLESS OTHERWISE SET FORTH IN ST'S TERMS AND CONDITIONS OF SALE ST DISCLAIMS ANY EXPRESS OR IMPLIED WARRANTY WITH RESPECT TO THE USE AND/OR SALE OF ST PRODUCTS INCLUDING WITHOUT LIMITATION IMPLIED WARRANTIES OF MERCHANTABILITY, FITNESS FOR A PARTICULAR PURPOSE (AND THEIR EQUIVALENTS UNDER THE LAWS OF ANY JURISDICTION), OR INFRINGEMENT OF ANY PATENT, COPYRIGHT OR OTHER INTELLECTUAL PROPERTY RIGHT.

UNLESS EXPRESSLY APPROVED IN WRITING BY AN AUTHORIZED ST REPRESENTATIVE, ST PRODUCTS ARE NOT RECOMMENDED, AUTHORIZED OR WARRANTED FOR USE IN MILITARY, AIR CRAFT, SPACE, LIFE SAVING, OR LIFE SUSTAINING APPLICATIONS, NOR IN PRODUCTS OR SYSTEMS WHERE FAILURE OR MALFUNCTION MAY RESULT IN PERSONAL INJURY, DEATH, OR SEVERE PROPERTY OR ENVIRONMENTAL DAMAGE. ST PRODUCTS WHICH ARE NOT SPECIFIED AS "AUTOMOTIVE GRADE" MAY ONLY BE USED IN AUTOMOTIVE APPLICATIONS AT USER'S OWN RISK.

Resale of ST products with provisions different from the statements and/or technical features set forth in this document shall immediately void any warranty granted by ST for the ST product or service described herein and shall not create or extend in any manner whatsoever, any liability of ST.

ST and the ST logo are trademarks or registered trademarks of ST in various countries.

Information in this document supersedes and replaces all information previously supplied.

The ST logo is a registered trademark of STMicroelectronics. All other names are the property of their respective owners.

© 2008 STMicroelectronics - All rights reserved

STMicroelectronics group of companies

Australia - Belgium - Brazil - Canada - China - Czech Republic - Finland - France - Germany - Hong Kong - India - Israel - Italy - Japan - Malaysia - Malta - Morocco - Singapore - Spain - Sweden - Switzerland - United Kingdom - United States of America

www.st.com