

Metal Film Resistors, Precision, High Stability

FEATURES



- Special stabilized metal alloy on high quality ceramic
- Very low TC and tight tolerances
- Excellent long term stability
- Suitable for precision measuring techniques and precision control engineering

STANDARD ELECTRICAL SPECIFICATIONS

MODEL	POWER RATING $P_{70^{\circ}\text{C}}$ W	LIMITING ELEMENT VOLTAGE MAX. V_{\cong}	TEMPERATURE COEFFICIENT ppm/K	TOLERANCE %	RESISTANCE RANGE Ω	E-SERIES
PMA0207	0.125 (0.25)* (0.4)*	250	5	0.05	on request	192
				0.1	100R - 100K	192
				0.25	100R - 100K	192
				0.5	100R - 100K	192
PMA0207	0.125 (0.25)* (0.4)*	250	10	0.05	on request	192
				0.1	100R - 100K	192
				0.25	100R - 100K	192
				0.5	100R - 100K	192
PMA0207	0.125 (0.25)* (0.4)*	250	15	0.05	on request	192
				0.1	47R - 511K	192
				0.25	47R - 511K	192
				0.5	47R - 511K	192
PMA0207	0.125 (0.25)*	250	25	0.05	on request	192
				0.1	47R - 511K	192
				0.25	47R - 511K	192
				0.5	47R - 511K	192

* For lower stability requirements

- Coating: green
- Marking: see appropriate catalog or web page

- For $TC \leq 10\text{ppm}/^{\circ}\text{C}$: temperature range - 25°C...+ 85°C
- Further values on request

ORDERING INFORMATION

PMA0207	5	1K87	.25%	A1
MODEL	TC ppm/K	RESISTANCE VALUE Ω	TOLERANCE \pm %	PACKAGING A1-Ammopack 1000 pcs

DIMENSIONS

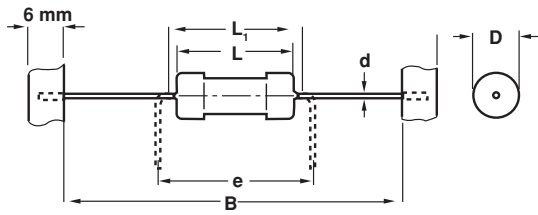

MODEL	DIMENSIONS [in millimeters]					
	D _{max}	L	L ₁ MAX	B	d	e
PMA0207	2.5 _{-0.3}	6.3 _{-0.5}	7.5	53±1	0.6	7.50

- Taping in acc. with IEC60286-1
- D and L measured in acc. with IEC60294
- d according to IEC60301

TECHNICAL SPECIFICATIONS				
PARAMETER	UNIT	PMA0207	PMA0207	PMA0207
Rated Dissipation at 70°C	W	0.125	0.25	0.4
Limiting Element Voltage ¹⁾	V _≧	≤ 250	≤ 250	≤ 250
Insulation Voltage (1min)	V _{eff}	> 500	> 500	> 500
Thermal Resistance	K/W	≤ 140	≤ 140	≤ 140
Insulation Resistance	Ω	≥ 10 ¹¹		
Category Temperature Range	°C	- 25/+ 85	- 55/+ 105	- 55/+ 125
Terminal Strength, axial	N	> 50	> 50	> 50
Failure Rate	10 ⁻⁹ /h	< 1		
Weight	g	0.22	0.22	0.22

¹⁾ Rated Voltage $\sqrt{P \times R}$

PACKAGING						
MODEL	T.C. ppm /°C	REEL		BOX		MIN. ORDER QTY
		PIECES / REEL	CODE	PIECES / BOX	CODE	PACKAGING UNITS
PMA0207	5 - 25	5000	R5	5000	A5	1
				2000	A2	1
				1000	A1	1
				500	AC	1

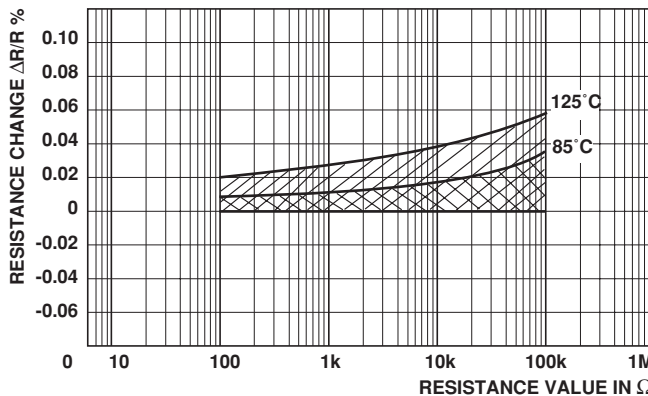
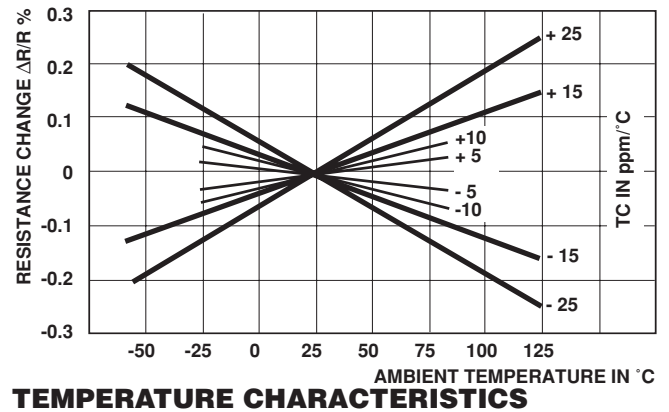
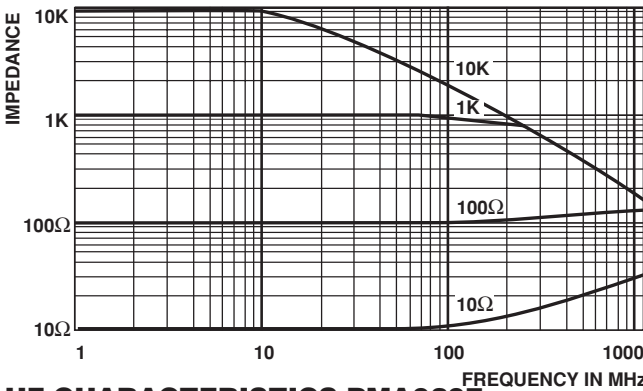
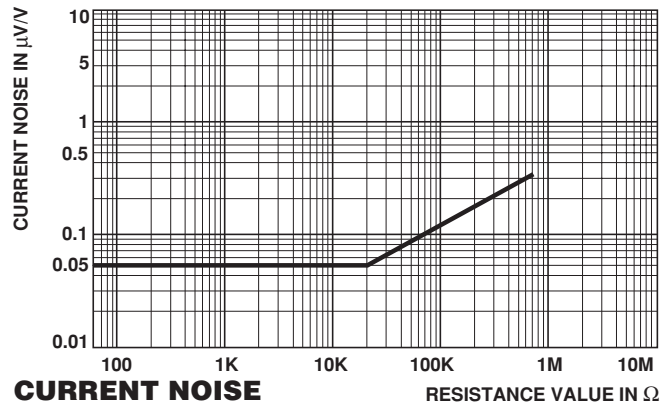
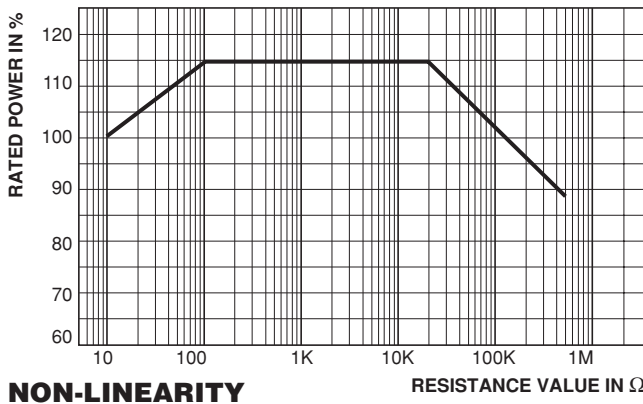
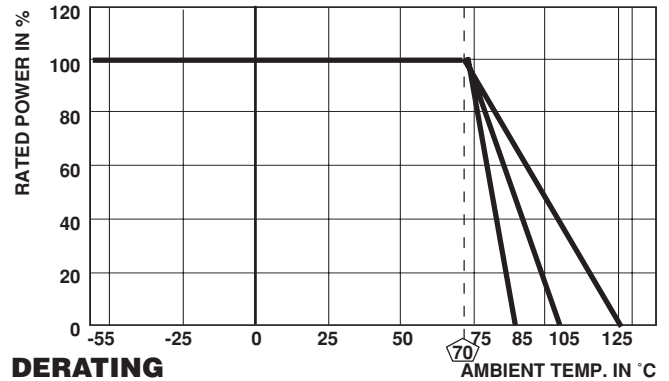
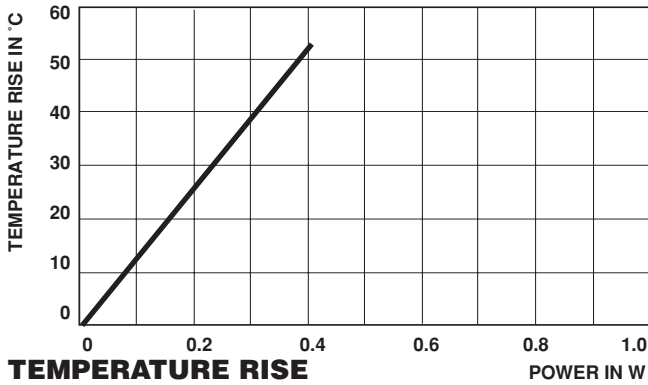

STABILITY NOMOGRAM, TYPICAL VALUES (For handling see General Information)

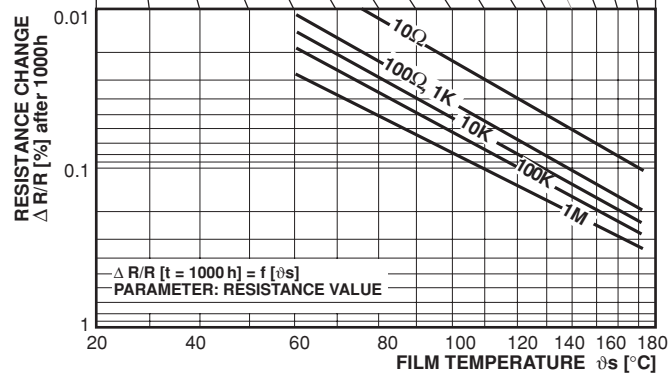
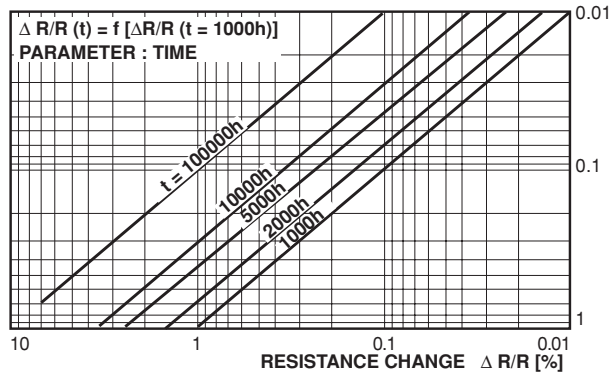
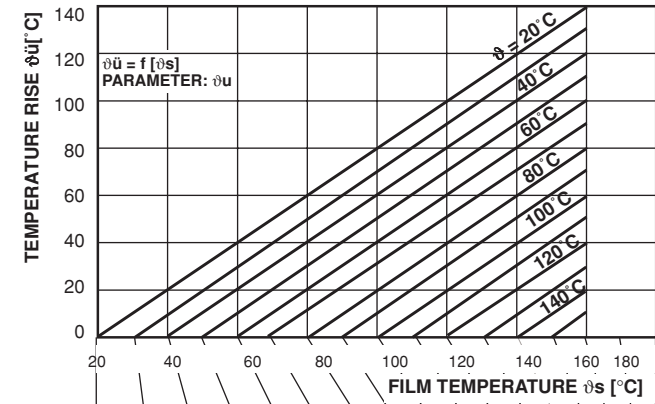
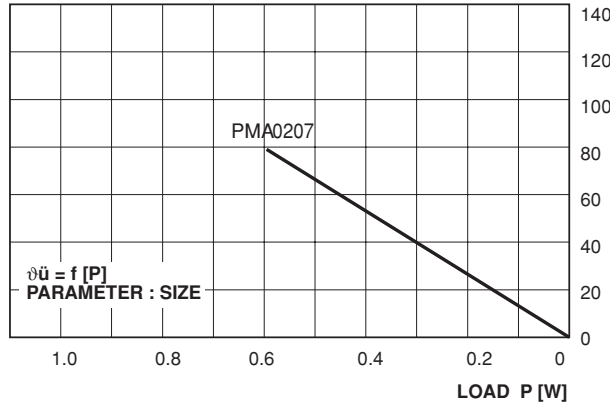

PERFORMANCE		
TEST	CONDITIONS OF TEST	REQUIREMENTS ¹⁾
Endurance Test at 70°C IEC 60115-1 4.25.1	1000 hours at 70°C P=0.25W, 1.5 hours "ON", 0.5 hours "OFF" 1000 hours at 70°C P=0.125W, 1.5 hours "ON", 0.5 hours "OFF"	≤ ± 0.1% ≤ ± 0.05%
Endurance at UCT IEC 60115-1 4.25-3	1000 hours at 85°C without load 8000 hours at 85°C without load	≤ ± 0.05% ≤ ± 0.1%
Overload Test IEC 60115-1 4.13	Short time overload for 5 seconds at 2.5 x rated voltage or ≤ twice the limiting element voltage	≤ ± 0.01%
Thermal Shock IEC 60115-1 4.19; IEC 60068-2-14	Rapid change between upper and lower category temperature	≤ ± 0.01%
Climatic Sequence IEC 60115-1 4.23	Dry heat, damp heat cyclic, cold, low air pressure	≤ ± 0.1%
Damp Heat Steady State IEC 60115-1 4.24; IEC 60068-2-3	56 days at 40°C and 93% relative humidity	≤ ± 0.1%
Resistance to Soldering Heat IEC 60115-1 4.18; IEC 60068-2-20	10 seconds at 260°C solder bath temperature	≤ ± 0.01%
Robustness of Terminations IEC 60115-1 4.16; IEC 60068-2-21	Tensile, bending and torsion	≤ ± 0.01%
Vibration IEC 60115-1 4.22; IEC 60068-2-6	0.75mm or 10g, 10 Hz - 500 Hz 6 hours	≤ ± 0.01%

¹⁾ Over a resistance range 100Ω to 100K, limits for change of resistance at test

APPLICABLE SPECIFICATIONS
<ul style="list-style-type: none"> • CECC40000 / 40300 • EN 140100 / IEC 60115-1