

SIEMENS



ICs for Communications

MIXER

PMB 2331 Version 1.2

Preliminary Data Sheet 02.96
www.DataSheet4U.com

T2331-XV12-P1-7600

PMB 2331		
Revision History:		Current Version: 02.96
Previous Version:		none
Page (in Version)	Page (in new Version)	Subjects (major changes since last revision)

Edition 02.96

**Published by Siemens AG,
Bereich Halbleiter, Marketing-
Kommunikation, Balanstraße 73,
81541 München**

© Siemens AG 1996.
All Rights Reserved.

Attention please!

As far as patents or other rights of third parties are concerned, liability is only assumed for components, not for applications, processes and circuits implemented within components or assemblies.

The information describes the type of component and shall not be considered as assured characteristics.

Terms of delivery and rights to change design reserved.

For questions on technology, delivery and prices please contact the Semiconductor Group Offices in Germany or the Siemens Companies and Representatives worldwide (see address list).

Due to technical requirements components may contain dangerous substances. For information on the types in question please contact your nearest Siemens Office, Semiconductor Group.

Siemens AG is an approved CECC manufacturer.

Packing

Please use the recycling operators known to you. We can also help you – get in touch with your nearest sales office. By agreement we will take packing material back, if it is sorted. You must bear the costs of transport.

For packing material that is returned to us unsorted or which we are not obliged to accept, we shall have to invoice you for any costs incurred.

Components used in life-support devices or systems must be expressly authorized for such purpose!

Critical components¹ of the Semiconductor Group of Siemens AG, may only be used in life-support devices or systems² with the express written approval of the Semiconductor Group of Siemens AG.

1 A critical component is a component used in a life-support device or system whose failure can reasonably be expected to cause the failure of that life-support device or system, or to affect its safety or effectiveness of that device or system.

2 Life support devices or systems are intended (a) to be implanted in the human body, or (b) to support and/or maintain and sustain human life. If they fail, it is reasonable to assume that the health of the user may be endangered.

Table of Contents		Page
1	Overview	4
1.1	Functional Description	4
1.2	Applications:	4
1.3	Pin Configuration	5
1.4	Pin Definitions and Functions	5
1.5	Functional Block Diagram	6
1.6	Circuit Description	7
2	Electrical Characteristics	8
2.1	Operational Range	8
2.2	Absolute Maximum Ratings	8
2.3	AC/DC Characteristics	9
2.4	Test Circuits	11
3	Package Outlines	19

1 Overview

1.1 Functional Description

- New B6HF bipolar technology, 25 GHz f_T
- Reduced external components
- Frequency range up to 2.0 GHz
- 2.7-4.5 V supply voltage
- Mixer current adjustable with external resistors
- 1.6mA current consumption typical (no external resistors used)
- - 40 °C to + 85 °C operational temperature range
- Gilbert cell mixer
- Very highly isolated RF, LO and IF ports
- Good crosstalk performance
- Low noise
- Low spurious signal content

1.2 Applications:

- Cellular radio mixer
- Cordless telephone mixer
- UHF transceiver
- RF data links
- RF/VHF/UHF frequency conversion

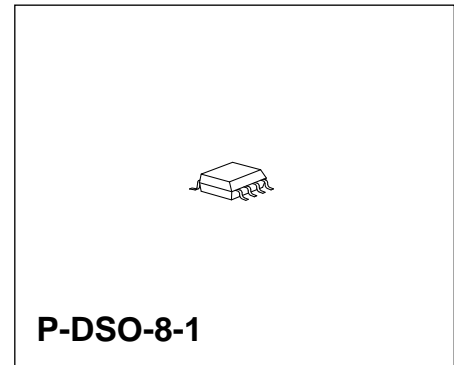

Type	Ordering Code	Package
PMB 2331		P-DSO-8-1

1.3 Pin Configuration
(top view)

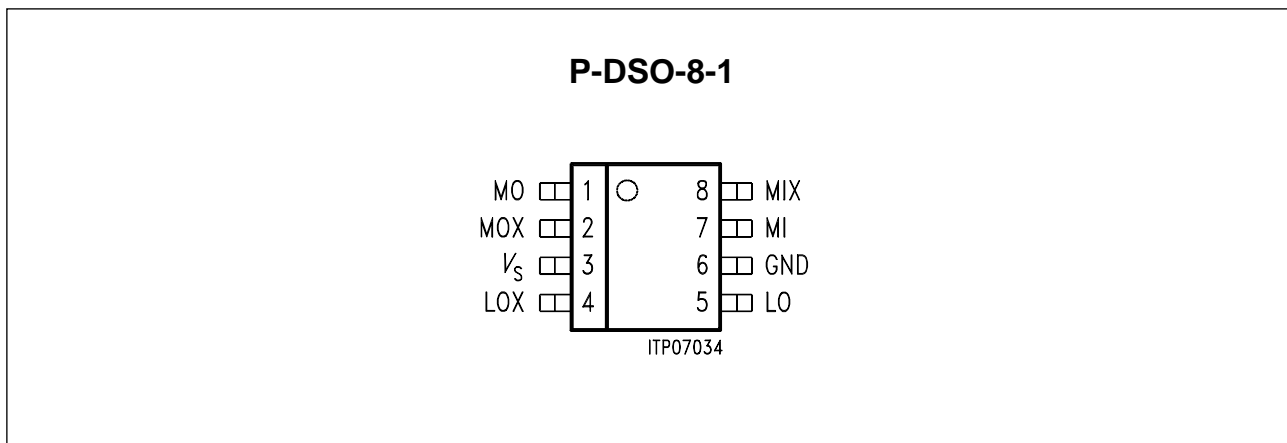
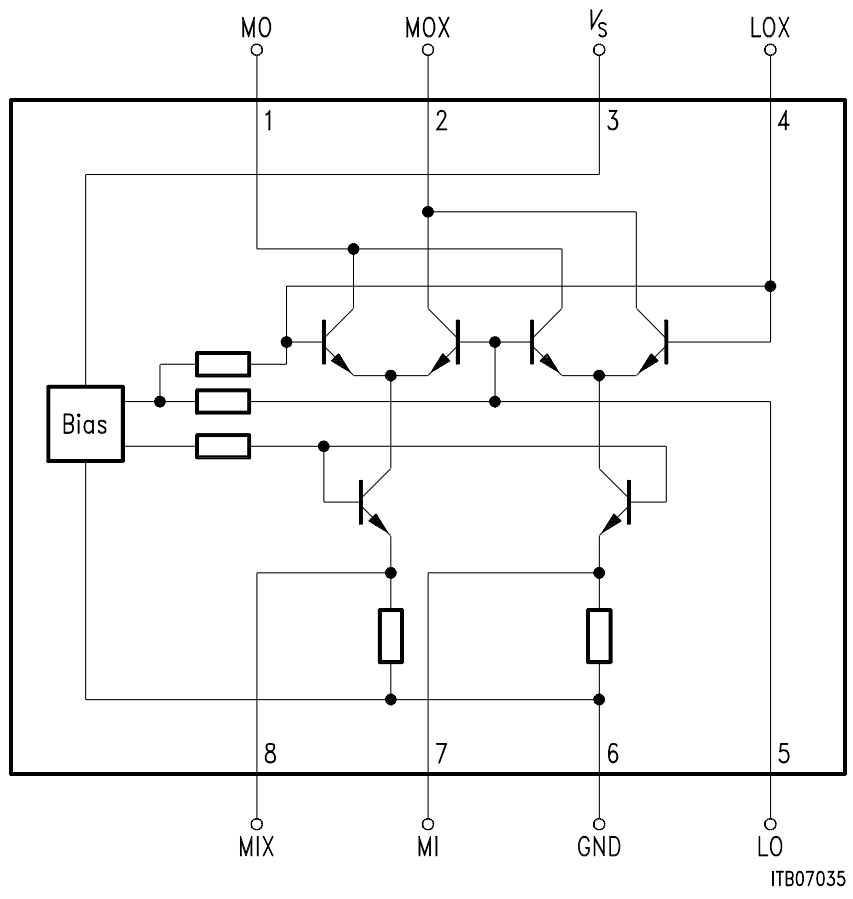

Figure 1

1.4 Pin Definitions and Functions

Pin No.	Symbol	Function
1	MO	Mixer signal output, open collector, not inverted
2	MOX	Mixer signal output, open collector, inverted
3	V_s	Mixer voltage supply
4	LOX	Mixer local oscillator signal base input, inverted
5	LO	Mixer local oscillator signal base input, not inverted
6	GND	Mixer ground
7	MI	Mixer signal emitter input, not inverted
8	MIX	Mixer signal emitter input, inverted

1.5 Functional Block Diagram



ITB07035

www.DataSheet4U.com

Figure 2

1.6 Circuit Description

The mixer used in this design is a general purpose up-/downconversion gilbert cell mixer. An amplified and filtered RF signal enters the IC via the pins MI/MIX. Using an external supplied local oscillator at LO/LOX a converted output signal is created at the open collector output pins MO/MOX, which have to be connected to an external voltage supply. The RF connections to the mixer inputs may be single ended or balanced, capacitive or inductive coupled.

Voltage supply for the mixer has to be connected to the pins V_S and GND. To increase the mixer current resistors need to be connected between the pins MI and GND, and between the pins MIX and GND.

Differential signals and symmetrical circuits are used throughout the IC.

An internal bias driver generates supply voltage and temperature compensated reference voltages.

All pins with the exception of GND are ESD protected.

2 Electrical Characteristics

2.1 Absolute Maximum Ratings

$$T_A = -40\text{ °C to }+85\text{ °C}$$

#	Parameter	Symbol	Limit Values		Unit	Remarks
			min.	max.		
1	Supply voltage	V_S	-0.3	5.5	V	
2a	Input voltage MI/MIX	$V_{MI/MIX}$	-0.3	1.9	V	$V_S = 0\text{ V}$
2b	Input voltage LO/LOX	$V_{LO/LOX}$	0.6	$V_S + 0.3$	V	
3	Open collector output voltage	$V_{MO/MOX}$	1.3	$V_S + 0.3$	V	
4	Differential input voltage	V_{DIFF}		2.0	V_{PP}	
5	Junction temperature	T_j		125	°C	
6	Storage temperature	T_S	-40	125	°C	
7	Thermal resistance	R_{thJA}		185	K/W	

Note: Maximum ratings are absolute ratings; exceeding only one of these values may cause irreversible damage to the integrated circuit.

2.2 Operational Range

Within the operational range the IC operates as described in the circuit description. The AC/DC characteristic limits are not guaranteed.

$$V_{VCC} = 2.7\text{ V...}4.5\text{ V}, T_A = -40\text{ °C to }85\text{ °C}$$

#	Parameter	Symbol	Limit Values		Unit	Remarks
			min.	max.		
1	MI/X Input Frequency	f_{MI}		2000	MHz	
2	LO/X Input Frequency	f_{LO}		2000	MHz	
3	IF Intermediate Frequency	f_{IF}		2000	MHz	

Note: Power levels refer to 50 Ω impedance.

In the operating range the functions given in the circuit description are fulfilled.

2.3 AC/DC Characteristics

$V_{VCC} = 2.7\text{ V to }4.5\text{V}, T_A = 25\text{ }^\circ\text{C}$

#	Parameter	Symbol	Limit Values			Unit	Test Condition	Test Circuit
			min.	typ.	max.			

Supply Current

1	Supply current, total IC	$I_{1,2,3}$		1.6		mA	without external resistors R1,2	1a,b
2	Supply current, total IC	$I_{1,2,3}$		4.6		mA	including external resistors R1,2 1)(=180 Ω)	1a,b

MIXER, Signal Input MI/MIX, Down Conversion, $R_{1,2} = 180\text{ }\Omega$

3	Input impedance	S_{11M}	Diagram 2a					
4	Max. input level, 1 db comp. at MO/MOX, IF = 45 MHz	P_{MI}		- 16		dBm	$f = 0.9\text{ GHz}$	1a
5	Input intercept point, $\Delta f = 800\text{ kHz}$, IF = 45 MHz	$IICP3_{MI}$		- 2		dBm	$f = 0.9\text{ GHz}$	1a
6	Blocking level $\Delta f = 800\text{ kHz}$, IF = 45 MHz	P_{BL}		- 16		dBm	$f = 0.9\text{ GHz}$	1a
7	Noise figure, ssb, (NF _{SSB} ≈ NF _{dsb} + 3 dB) IF = 45 MHz	F_{MI}		9.5		dB	$f = 0.9\text{ GHz}$ ²⁾	1a

MIXER, Local Oscillator Input LO/LOX

8	Input impedance	S_{11LO}	Diagram 2b					
9	Input level	P_{LO}		- 3		dBm	$f = 0.9\text{ GHz}$ ³⁾	1a,b

Notes see page 10.

2.3 AC/DC Characteristics (cont'd)

$V_{VCC} = 2.7 \text{ V to } 4.5\text{V}, T_A = 25 \text{ }^\circ\text{C}$

#	Parameter	Symbol	Limit Values			Unit	Test Condition	Test Circuit
			min.	typ.	max.			

MIXER, Signal Output MO/MOX, Down Conversion, $R_{1,2} = 180 \text{ } \Omega$

10	Output current	I_{MO+} I_{MOX}		4.0		mA	including external resistors R1, R2	1a,b
11	Output resistance	R_{MODiff}		38		k Ω	IF = 45 MHz	1a
12	Output resistance	R_{MODiff}		24		k Ω	IF = 300 MHz	1b
13	Output capacitance	C_{MODiff}		0.34		pF	IF = 45 MHz	1a
14	Output capacitance	C_{MODiff}		0.38		pF	IF = 300 MHz	1b
15	Power gain, IF = 45 MHz	P_{MI}		14		dB	$f = 0.9 \text{ GHz}$	1a
16	Power gain, IF = 300 MHz	P_{MI}		7		dB	$f = 0.9 \text{ GHz}$	1b

MIXER, Isolation Between In-/Output, 0.9 GHz

17	MI to MO	A_{MI-MO}		30		dB	$f_{MI} = 945 \text{ MHz}$ $f_{LO} = 900 \text{ MHz}$	1a
18	LO to MO	A_{LO-MO}		50		dB	"	1a
19	LO to MI	A_{LO-MI}		50		dB	"	1a
20	MO to MI	A_{MO-MI}		50		dB	"	1a
21	MO to LO	A_{MO-LO}		60		dB	"	1a

- 1) Minimum value for $R_{41} = R_2 = 33 \text{ } \Omega$.
- 2) Matching network used.
- 3) Referenced for specified mixer performance.

Note: The listed characteristics are ensured over the operating range of the integrated circuit. Typical characteristics specify mean values expected over the production spread. If not otherwise specified, typical characteristics apply at $T_A = 25^\circ\text{C}$ and the given supply voltage.

2.4 Test Circuits

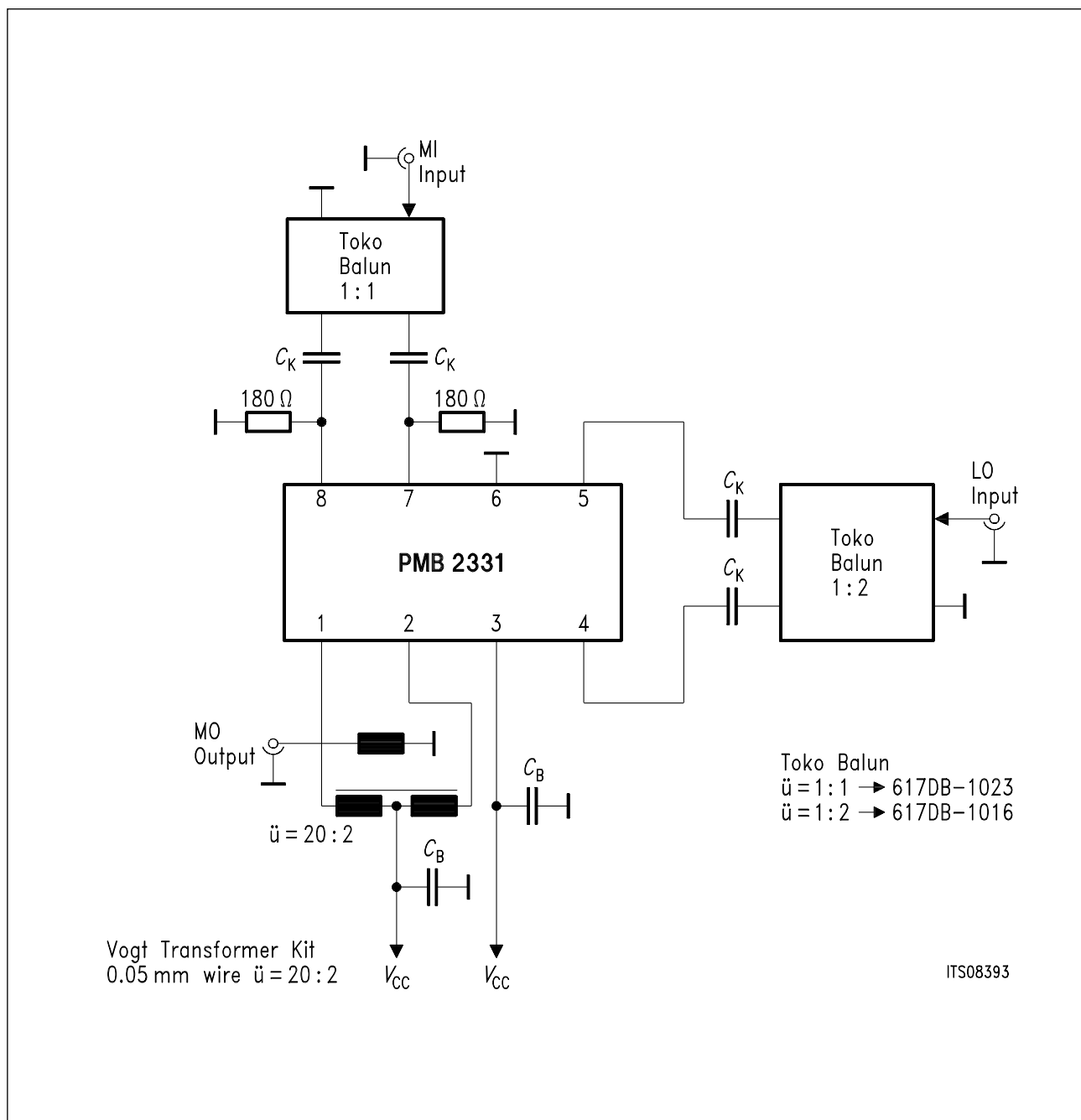

Figure 3
Test Circuit 1a

Test Circuit for 45 MHz Intermediate Frequency

Test Circuit	f_{IF} [MHz]	C_B [pF]	C_K [pF]	X
1a	45	15 p/100 p	15 p	X

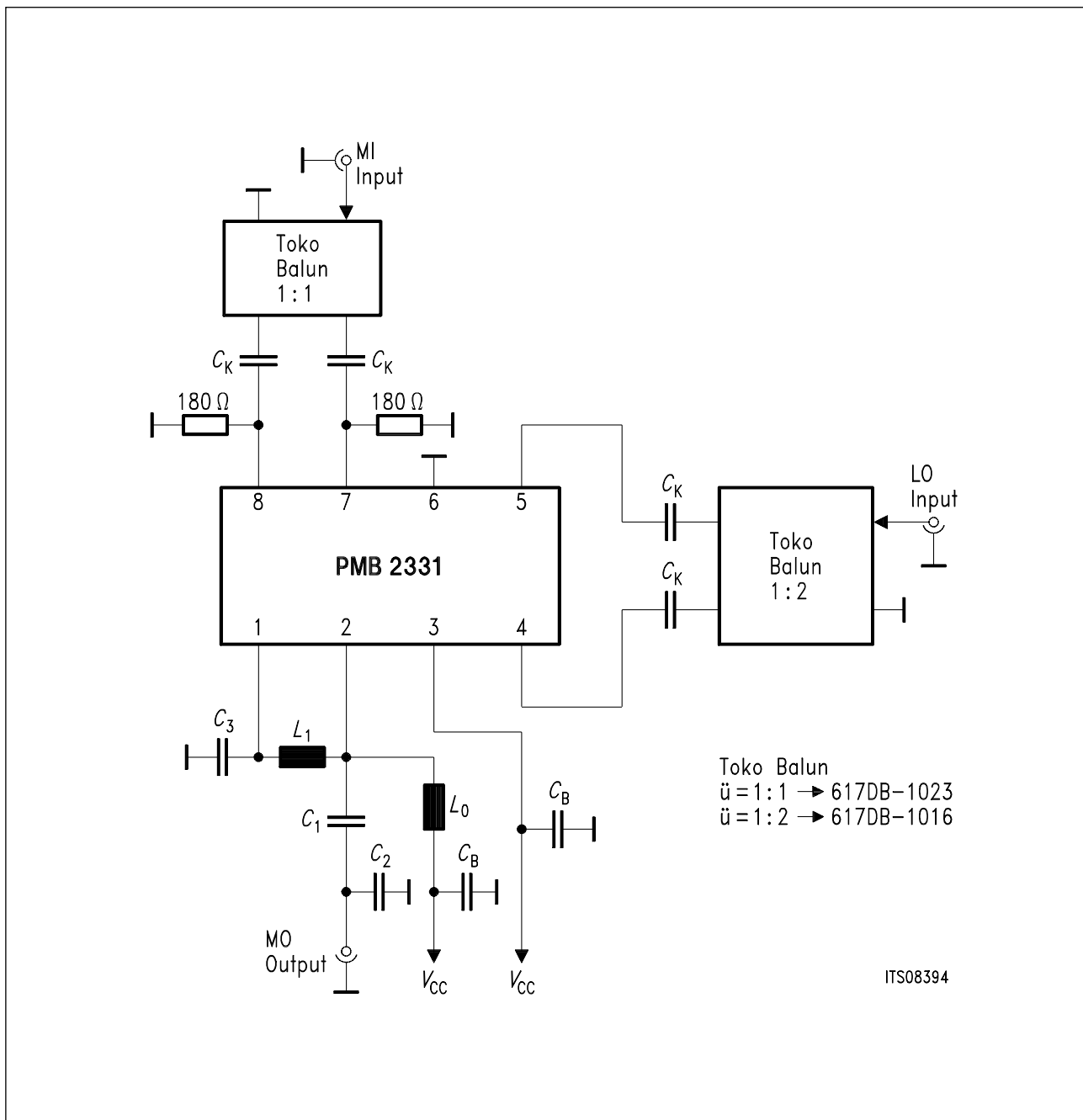

Figure 4
Test Circuit 1b

Test Circuit for 300 MHz Intermediate Frequency

Test Circuit	f_{IF} [MHz]	L0[nH]	L1[nH]	C1[pF]	C2[pF]	C3[pF]	C_K [pF]
1b	≈ 300	680	150	2.7	12	1.8	15p

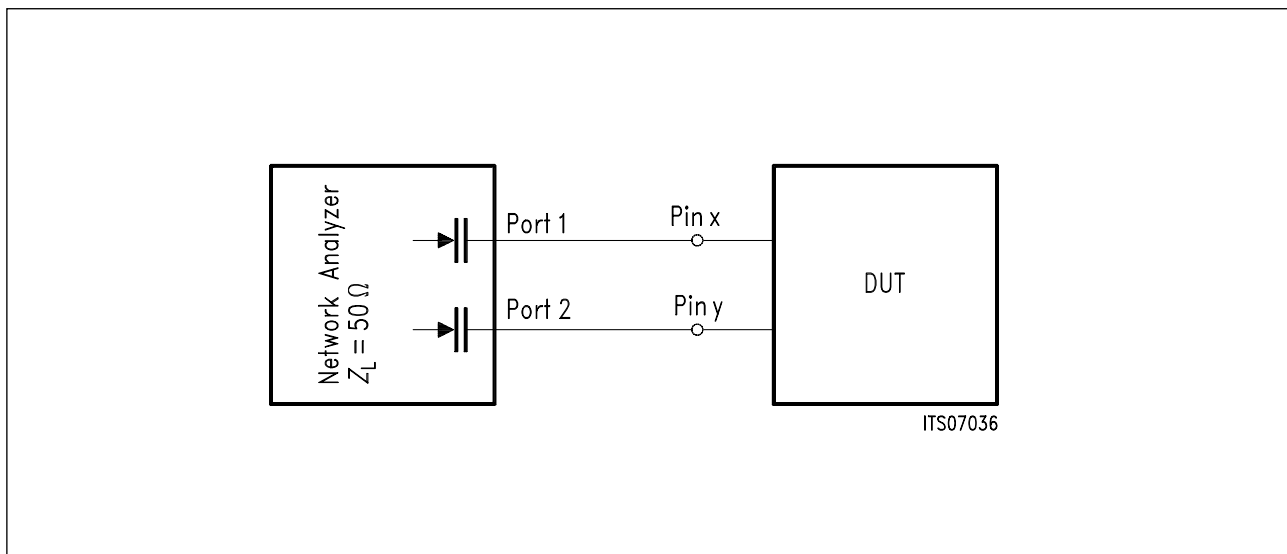

Figure 5
Test Circuit 2
S-Parameter Measurement of Mixer
S11, S12, S21, S2

Test	Test Frequency [GHz]	Pin X	Pin Y
LO-Input impedance	.. - 3.0	4	5
Mi-Input impedance	.. - 3.0	7	8
MO-Output impedance	.. - 3.0	1	2

The S-Parameters are tested at the indicated frequency and the equivalent parallel or series circuit is calculated on this base.

Via the NWA the capacitive coupling is done and the open collector pins are connected to V_{CC} . The output levels at port1 and 2 for pin x and y are – 30 dbm for MI and MO-impedances and – 5 dbm for the LO impedance. S-Parameters have to be considered as design hints and are measured with SIEMENS testboards (RT/Duroid 5880 Teflon, $\epsilon = 2.2$).

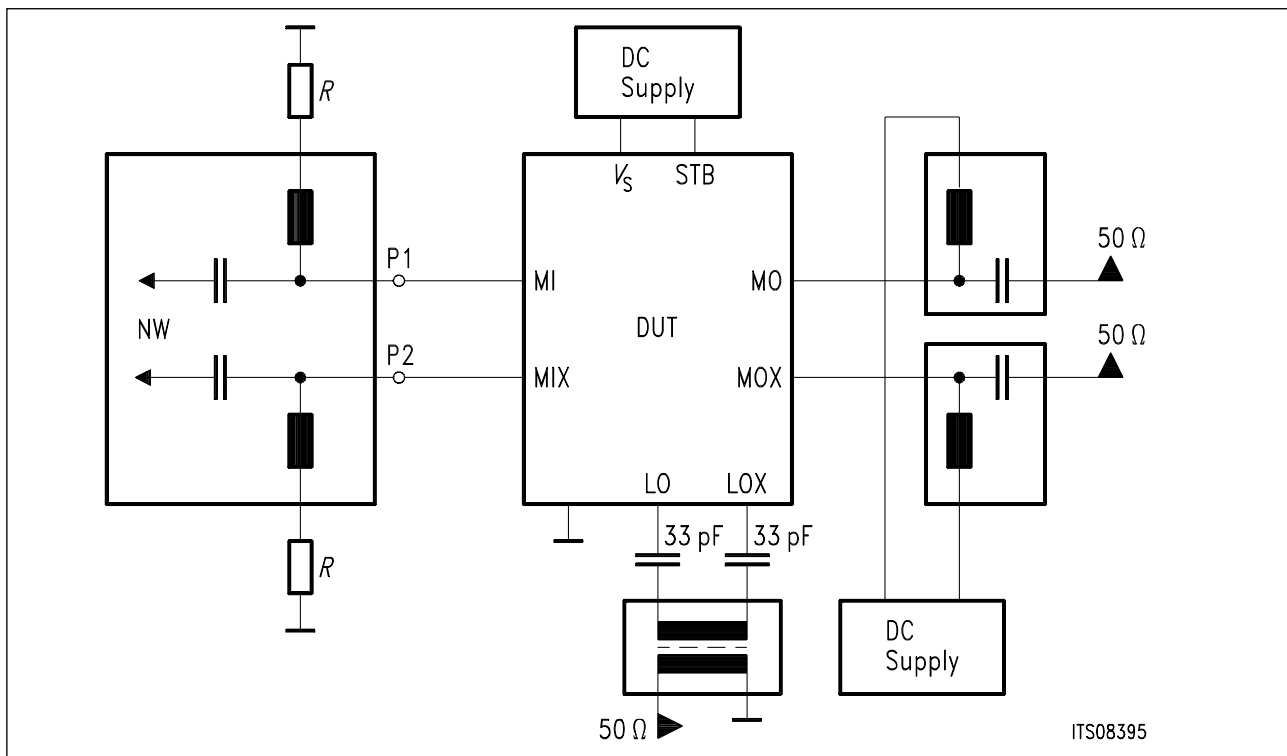

Figure 6
Test Circuit 2a
Mixer Input Impedance Measurement

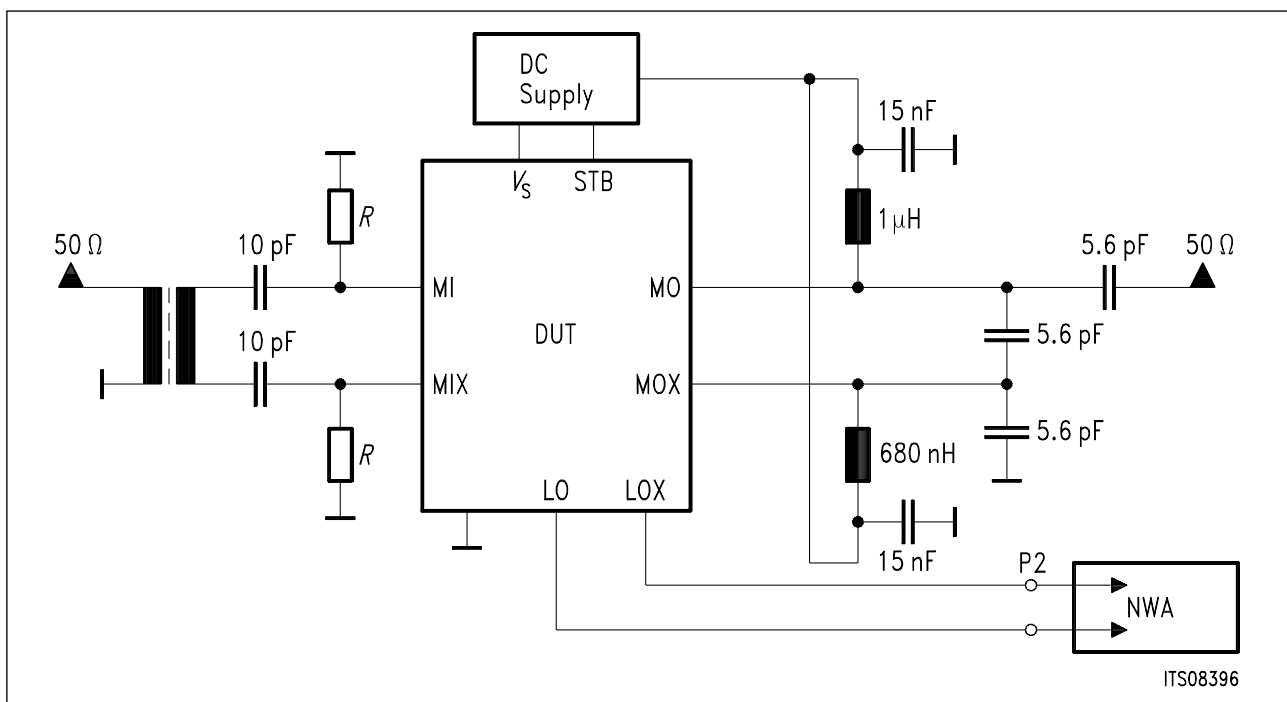

Figure 7
Test Circuit 2b
Mixer Local Oscillator Impedance Measurement

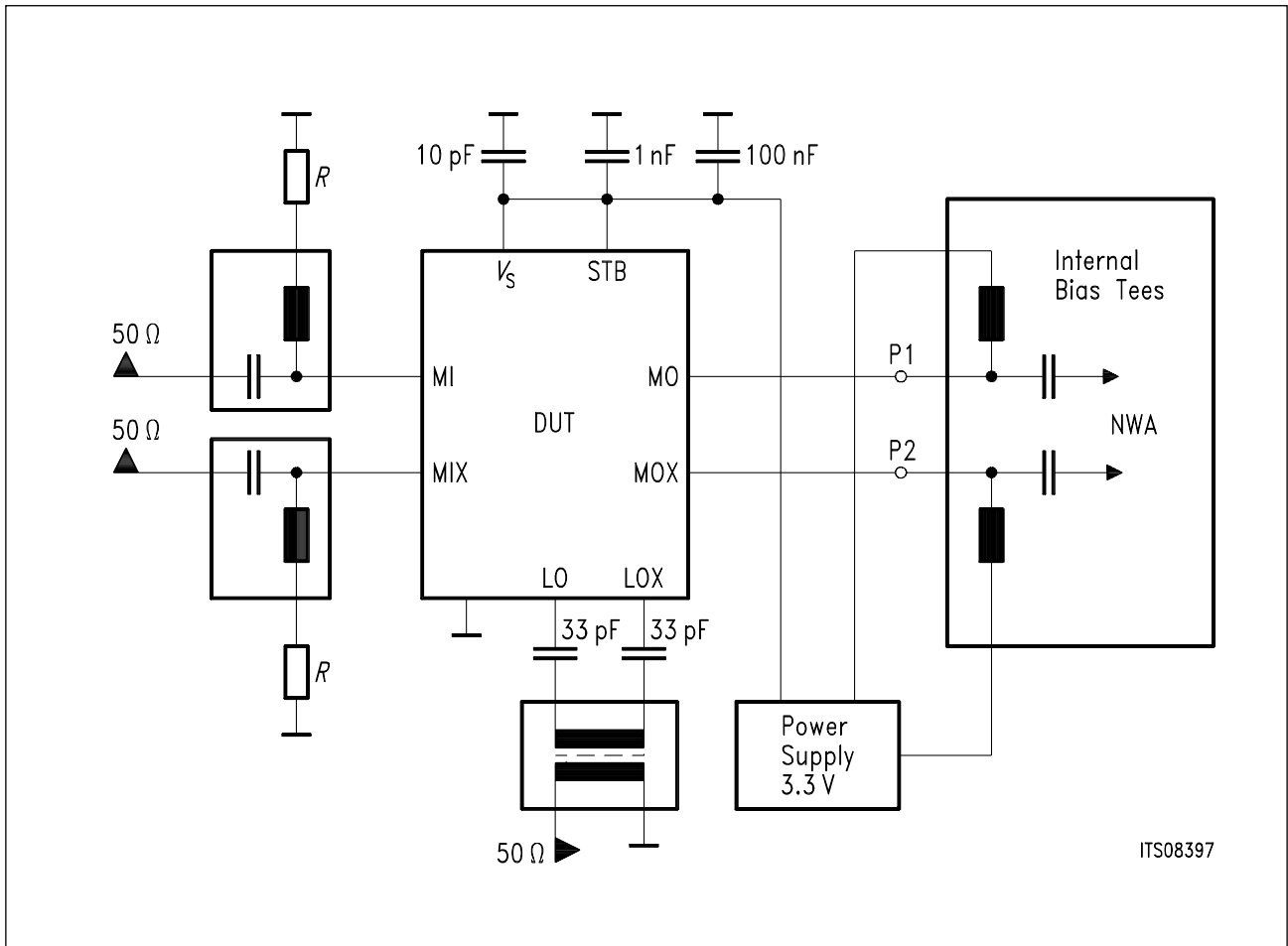
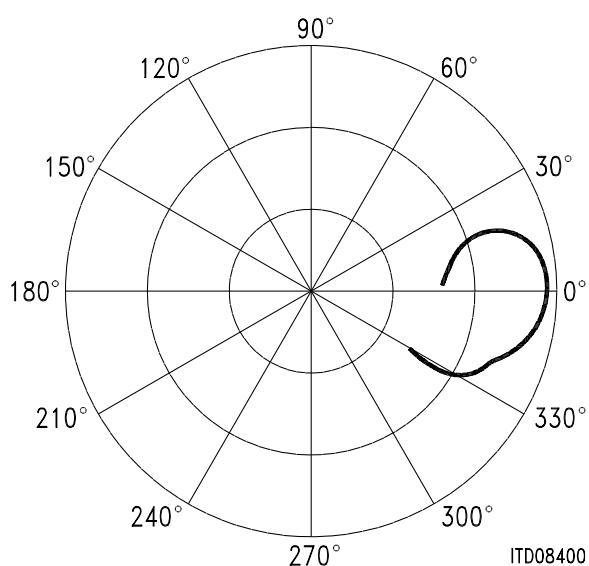
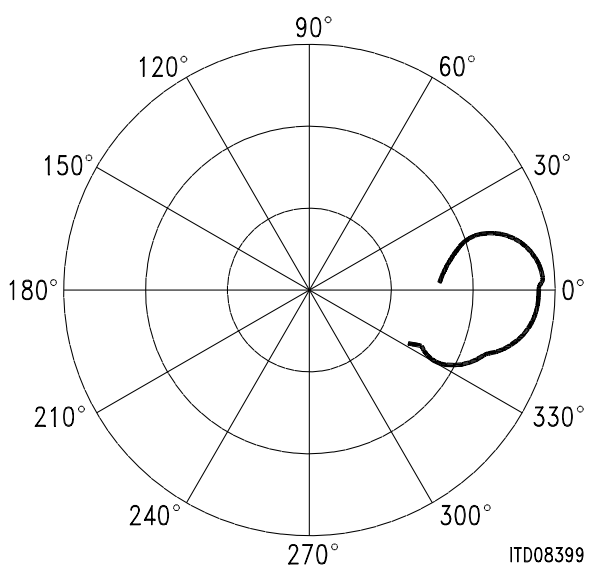
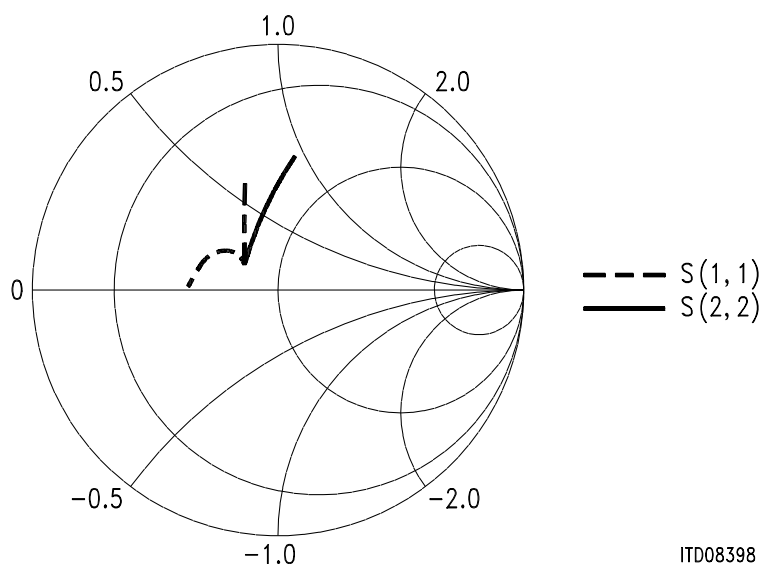

Figure 8
Test Circuit 2c
Mixer Output Impedance Measurement

Electrical Characteristics

Diagram 2a
S-Parameter Mixer Input MI Impedance,
 $I_{MO/MOX} = 4 \text{ mA}; f = .. 3 \text{ GHz}$



Electrical Characteristics

Diagram 2b
S-Parameter Mixer Input LO
 Impedance, $I_{MO/MOX} = 4 \text{ mA}; f = .. 3 \text{ GHz}$

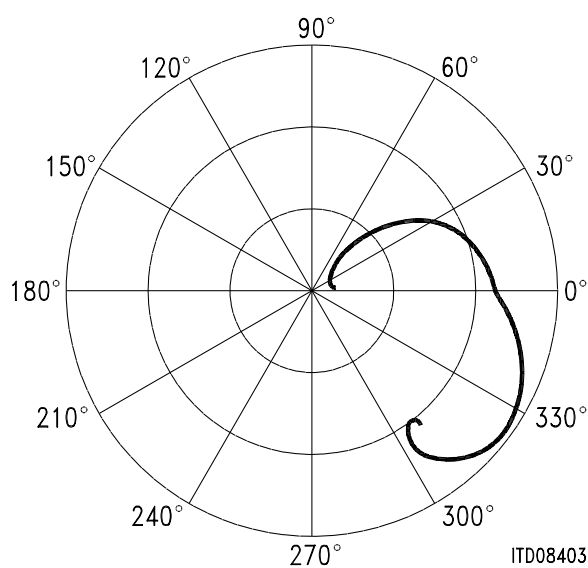
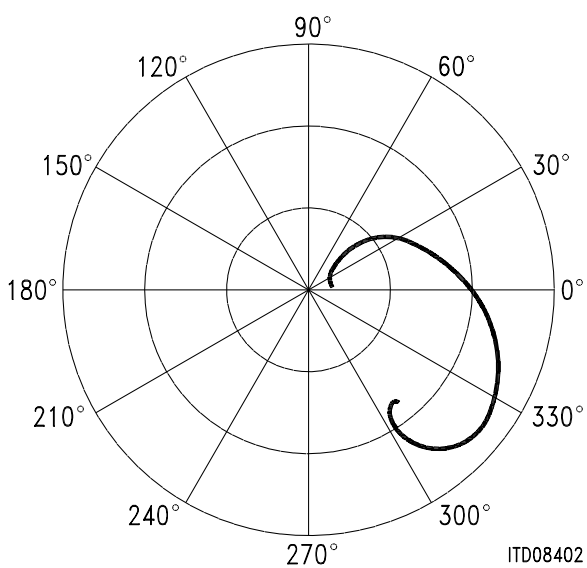
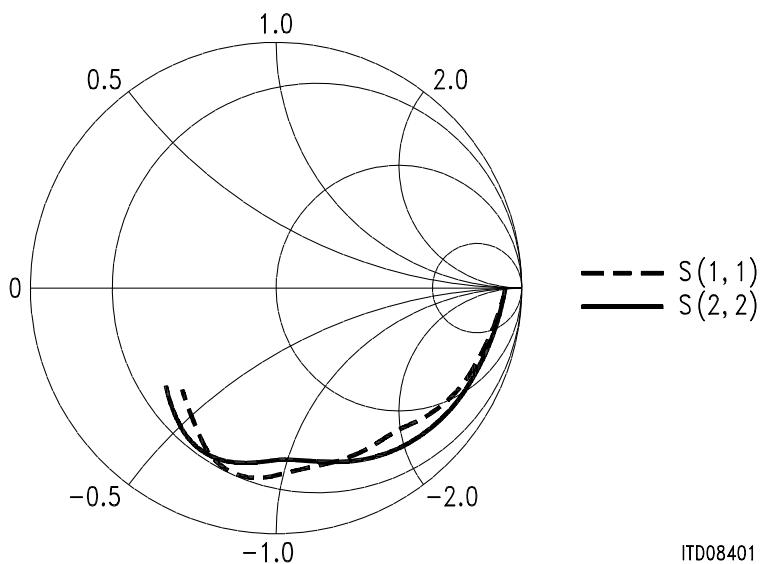

Application Circuit

Application circuit: In evaluation

General applications also refer to the PMB 2330 application note (different values)

3 Package Outlines

P-DSO-8-1
(Plastic Dual Small Outline Package)

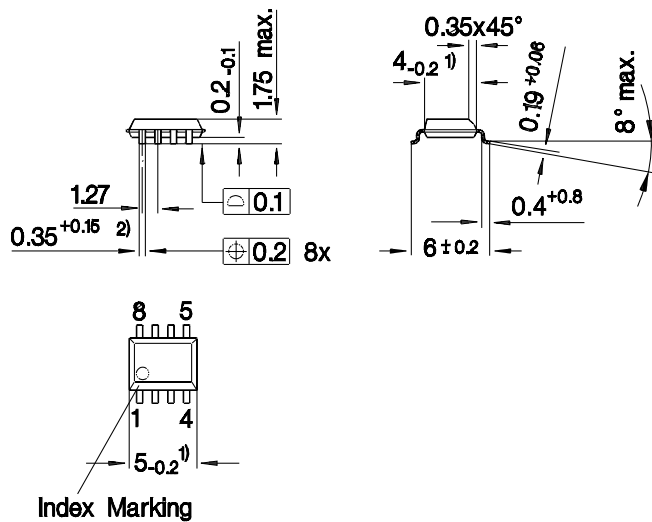

- 1) Does not include plastic or metal protrusion of 0.15 max. per side
- 2) Does not include dambar protrusion

GPS05121

Sorts of Packing

Package outlines for tubes, trays etc. are contained in our Data Book "Package Information".

SMD = Surface Mounted Device

Dimensions in mm

