

PMT9101DM-T2QU: Optical Track Sensor

General Description

The PMT9101DM-T2QU is PixArt Imaging's high performance Optical Track Sensor (OTS) using optical navigation technology that enables high accuracy digital surface tracking. The OTS integrates optical sensor and LED source in a single package, with built-in image recognition engine, which does not require code wheel, code strip or any special marking on tracking surface. The OTS sensor offers a direct SPI output, together with motion interrupt signal, the OTS sensor provides easy integration with the host system.

Key Features

- Integrated 16 pin molded lead-frame DIP package
- Four wire serial port interface (SPI)
- Repeated Error of 1% (typical)
- High speed motion detection 150 ips (typical) and acceleration 30 g (max)
- High resolutions up to 8200 cpi with 100 cpi step size
- External interrupt output for motion detection
- Internal Oscillator – no clock input needed

Applications

- Printers / Handheld Printers
- Scanners / Handheld Scanners
- Media / Multi-Function Printers
- Consumer Product Applications
- Devices that require high accuracy to detect tracking or the presence of surfaces

Key Parameters

Parameter	Value
Interface	4-Wire SPI
Supply Voltage (V)	V _{DD} : 1.8 – 2.1
Resolution (cpi)	8200
Speed (ips)	150 (typical)
Max Frame Rate (fps)	Up to 7500
Package Type	16 pin molded lead-frame DIP package
Optical Lens Magnification	1:1

Ordering Information

Part Number	Package Type
PMT9101DM-T2QU	16-pin DIP Package
LM19-LSI	Lens



For any additional inquiries, please contact us at <http://www.pixart.com/contact.asp>

1.3 Signal Description

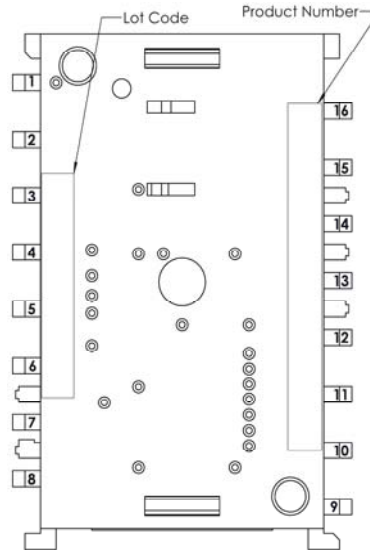

Figure 2. Pin Configuration

Table 1. PMT9101 Signal Pins Description

Pin No.	Signal Name	Type	Description
Functional Group:		Power Supplies	
3	VDDPIX	Output	LDO output for selective analog circuit
4	VDD	Power	Input power supply
5	VDDIO	Power	I/O reference voltage
8	GND	Ground	Ground
Functional Group:		Control Interface	
10	SCLK	Input	Serial data clock
11	MOSI	Input	Serial data input
12	MISO	Output	Serial data output
13	NCS	Input	Chip select (active low)
Functional Group:		Functional I/O	
7	NRESET	Input	Chip reset (active low)
9	MOTION	Output	Motion detect
15	LED_P	Output	LED Anode
Functional Group:		Data Interface	
1	NC	NC	No connection (float)
2	NC	NC	No connection (float)
6	NC	NC	No connection (float)

Pin No.	Signal Name	Type	Description
14	NC	NC	No connection (float)
16	NC	NC	No connection (float)

2.0 Operating Specifications

2.1 Regulatory Requirements

- Passes FCC “Part15, Subpart B, Class B”, “CISPR 22 1997 ClassB” and worldwide analogous emission limits when assembled into a product with shielded cable and following PixArt Imaging’s recommendations.
- Passes IEC 62471: 2006 Photo biological safety of lamps and lamp systems.

2.2 Absolute Maximum Ratings

Table 2. Absolute Maximum Ratings

Parameters	Symbol	Min.	Max.	Unit	Notes
Storage Temperature	T_S	-40	85	°C	
Lead Solder Temperature	T_{SOLDER}		260	°C	For 7 seconds, 1.6mm below seating plane
Supply Voltage	V_{DD}	-0.5	2.1	V	
	V_{DDIO}	-0.5	3.6	V	
Input Voltage	V_{IN}	-0.5	3.6	V	All I/O pins
ESD	ESD_{HBM}		2	kV	All pins (Human Body Model)

Notes:

1. Maximum Ratings are those values beyond which damage to the device may occur.
2. Exposure to these conditions or conditions beyond those indicated may adversely affect device reliability. Functional operation under absolute maximum-rated conditions is not implied.
3. Functional operation should be restricted to the Recommended Operating Conditions.

2.3 Recommended Operating Conditions

Table 3. Recommended Operating Conditions

Description	Symbol	Min.	Typ.	Max.	Unit	Notes
Operating Temperature	T_A	0		40	°C	
Power Supply Voltage	V_{DD}	1.8	1.9	2.1	V	Excluding supply noise
	V_{DDIO}	1.8	1.9	3.6	V	Excluding supply noise ($V_{DDIO} \geq V_{DD}$)
Power Supply Rise Time	t_{RT}	0.15		20.00	ms	0 to VDD min
Supply Noise (Sinusoidal)	V_{NA}			100	mV _{p-p}	10 kHz – 75 MHz
Serial Port Clock Frequency	f_{SCLK}			2	MHz	50% duty cycle
Distance from Lens Reference Plane to Tracking Surface	Z	2.2	2.4	2.6	mm	
Speed	S			150	ips	
Repeated Error	R		1		%	On white paper & photo paper at nominal height of 2.4mm @ 1 ips velocity over 1 inch travel distance @ 10 ips velocity over 6 inch travel distance
Acceleration	A			30	g	In run mode

Note: PixArt does not guarantee the performance if the operating temperature is beyond the specified limit.

2.4 DC Characteristics

Table 4. DC Electrical Specifications

Parameters	Symbol	Min.	Typ.	Max.	Unit	Conditions
Supply Current	I_{DD_RUN}		27.3		mA	Average current consumption, including LED current with 1ms polling.
Power Down Current	I_{PD}		10		uA	
Input Low Voltage	V_{IL}			$0.3 * V_{DDIO}$	V	SCLK, MOSI, NCS
Input High Voltage	V_{IH}	$0.7 * V_{DDIO}$			V	SCLK, MOSI, NCS
Input Hysteresis	V_{I_HYS}		100		mV	SCLK, MOSI, NCS
Input Leakage Current	I_{LEAK}		± 1	± 10	uA	$V_{in} = V_{DDIO}$ or 0V, SCLK, MOSI, NCS
Output Low Voltage	V_{OL}			0.45	V	$I_{OUT} = 1mA$, MISO, MOTION
Output High Voltage	V_{OH}	$V_{DDIO} - 0.45$			V	$I_{OUT} = -1mA$, MISO, MOTION

Note: All the parameters are tested under operating conditions: $V_{DD} = 1.9V$, $V_{DDIO} = 1.9V$, LED current = 12 mA, Internal Clock = 70 MHz, Internal Slow Clock = 1.1 kHz, $T_A = 25^\circ C$.

2.5 AC Characteristics

Table 5. AC Electrical Specifications

Parameters	Symbol	Min.	Typ.	Max.	Unit	Conditions
Motion Delay After Reset	$t_{MOT-RST}$	50			ms	From reset to valid motion, assuming motion is present
Shutdown	t_{STDWN}			500	us	From Shutdown mode active to low current
Wake from Shutdown	t_{WAKEUP}	50			ms	From Shutdown mode inactive to valid motion. Notes: A RESET must be asserted after a shutdown. Refer to section "Notes on Shutdown", also note $t_{MOT-RST}$.
MISO Rise Time	t_{r-MISO}		50		ns	$C_L = 100pF$
MISO Fall Time	t_{f-MISO}		50		ns	$C_L = 100pF$
MISO Delay After SCLK	$t_{DLY-MISO}$			90	ns	From SCLK falling edge to MISO data valid, no load conditions
MISO Hold Time	$t_{hold-MISO}$	200			ns	Data held until next falling SCLK edge
MOSI Hold Time	$t_{hold-MOSI}$	200			ns	Amount of time data is valid after SCLK rising edge
MOSI Setup Time	$t_{setup-MOSI}$	120			ns	From data valid to SCLK rising edge
SPI Time Between Write Commands	t_{SWW}	180			μs	From rising SCLK for last bit of the first data byte, to rising SCLK for last bit of the second data byte.
SPI Time Between Write And Read Commands	t_{SWR}	180			μs	From rising SCLK for last bit of the first data byte, to rising SCLK for last bit of the second address byte.
SPI Time Between Read And Subsequent Commands	t_{SRW} t_{SRR}	20			μs	From rising SCLK for last bit of the first data byte, to falling SCLK for the first bit of the address byte of the next command.
SPI Read Address-Data Delay	t_{SRAD}	160			μs	From rising SCLK for last bit of the address byte, to falling SCLK for first bit of data being read.

SPI Read Address-Data Delay for Burst Mode Motion Read	t_{SRAD_MOTBR}	35			μs	From rising SCLK for last bit of the address byte, to falling SCLK for first bit of data being read. Applicable for Burst Mode Motion Read only.
NCS Inactive After Motion Burst	t_{BEXIT}	500			ns	Minimum NCS inactive time after motion burst before next SPI usage
NCS To SCLK Active	$t_{NCS-SCLK}$	120			ns	From last NCS falling edge to first SCLK rising edge
SCLK To NCS Inactive (For Read Operation)	$t_{SCLK-NCS}$	120			ns	From last SCLK rising edge to NCS rising edge, for valid MISO data transfer
SCLK To NCS Inactive (For Write Operation)	$t_{SCLK-NCS}$	35			μs	From last SCLK rising edge to NCS rising edge, for valid MOSI data transfer
NCS To MISO High-Z	$t_{NCS-MISO}$			500	ns	From NCS rising edge to MISO high-Z state
MOTION Rise Time	$t_{r-MOTION}$		50		ns	$C_L = 100pF$
MOTION Fall Time	$t_{f-MOTION}$		50		ns	$C_L = 100pF$
Input Capacitance	C_{in}		50		pF	SCLK, MOSI, NCS
Load Capacitance	C_L			100	pF	MISO, MOTION
Transient Supply Current	I_{DDT}			70	mA	Max supply current during the supply ramp from 0V to VDD with min 150 μs and max 20ms rise time. (Does not include charging currents for bypass capacitors)
	I_{DDTIO}			60	mA	Max supply current during the supply ramp from 0V to VDDIO with min 150 μs and max 20ms rise time. (Does not include charging currents for bypass capacitors)

Notes:

1. All the parameters are tested under operating conditions: $V_{DD} = 1.9V$, $V_{DDIO} = 1.9V$, $T_A = 25^\circ C$.
2. Refer Figure 10. Write Operation, Figure 11. MOSI Set-up and Hold Time, Figure 12. Read Operation, Figure 13. MISO Delay and Hold Time, Figure 14. Timing between two Write commands, Figure 15. Timing between Write and either Write or subsequent Read commands, and Figure 16. Timing between Read and either Write or subsequent Read commands.

3.0 Mechanical Specifications

3.1 Package Marking

Refer to Figure 2. Pin Configuration for the code marking location on the device package.

Table 6. Code Identification

Code	Marking	Description
Product Number	PMT9101DM-T2QU	Part number label
Lot Code	AYWWXXXXX	A: Assembly House Y: Year WW: Week XXXXX: Reserved as PixArt reference

3.2 Package Outline Drawing

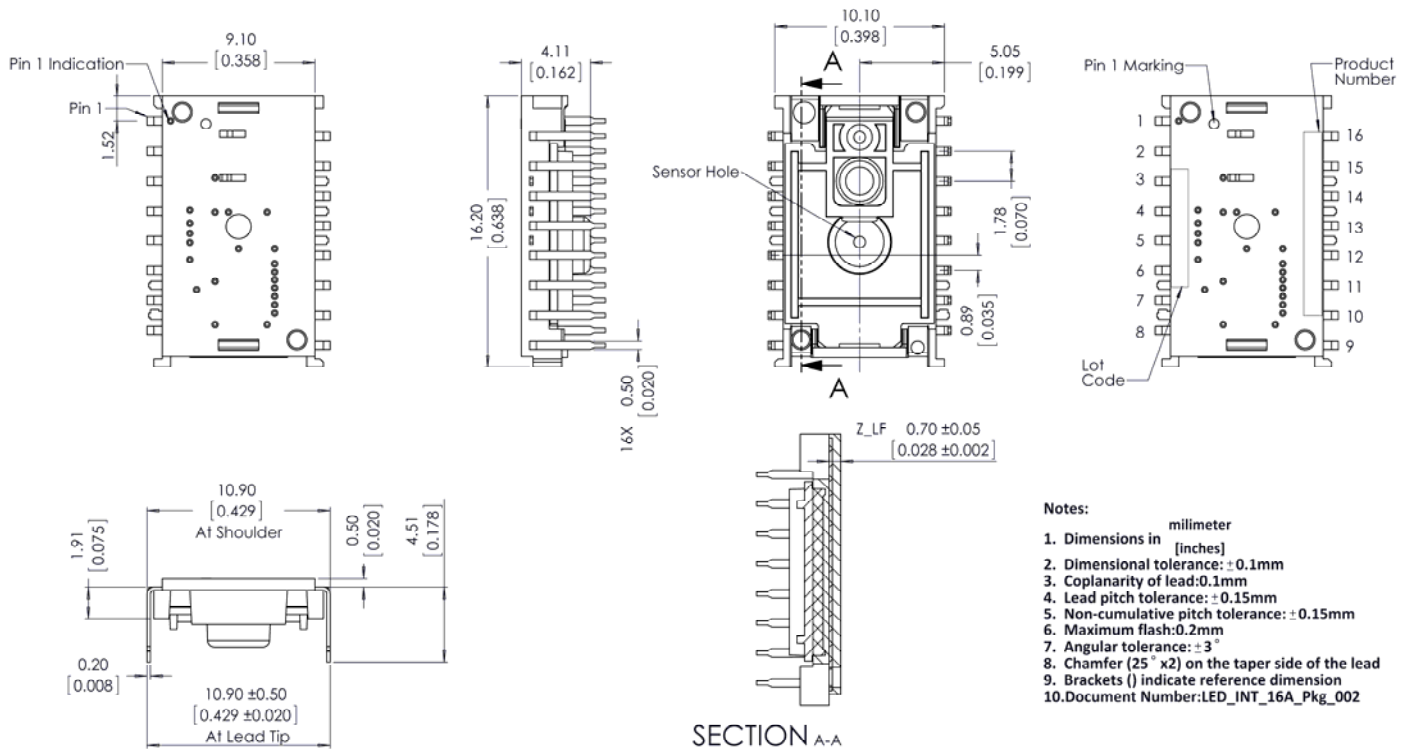

CAUTION: It is advised that normal static discharge precautions be taken in handling and assembling of this component to prevent damage and/or degradation which may be induced by ESD.

Figure 3. Package Outline Drawing

3.3 Assembly Drawings

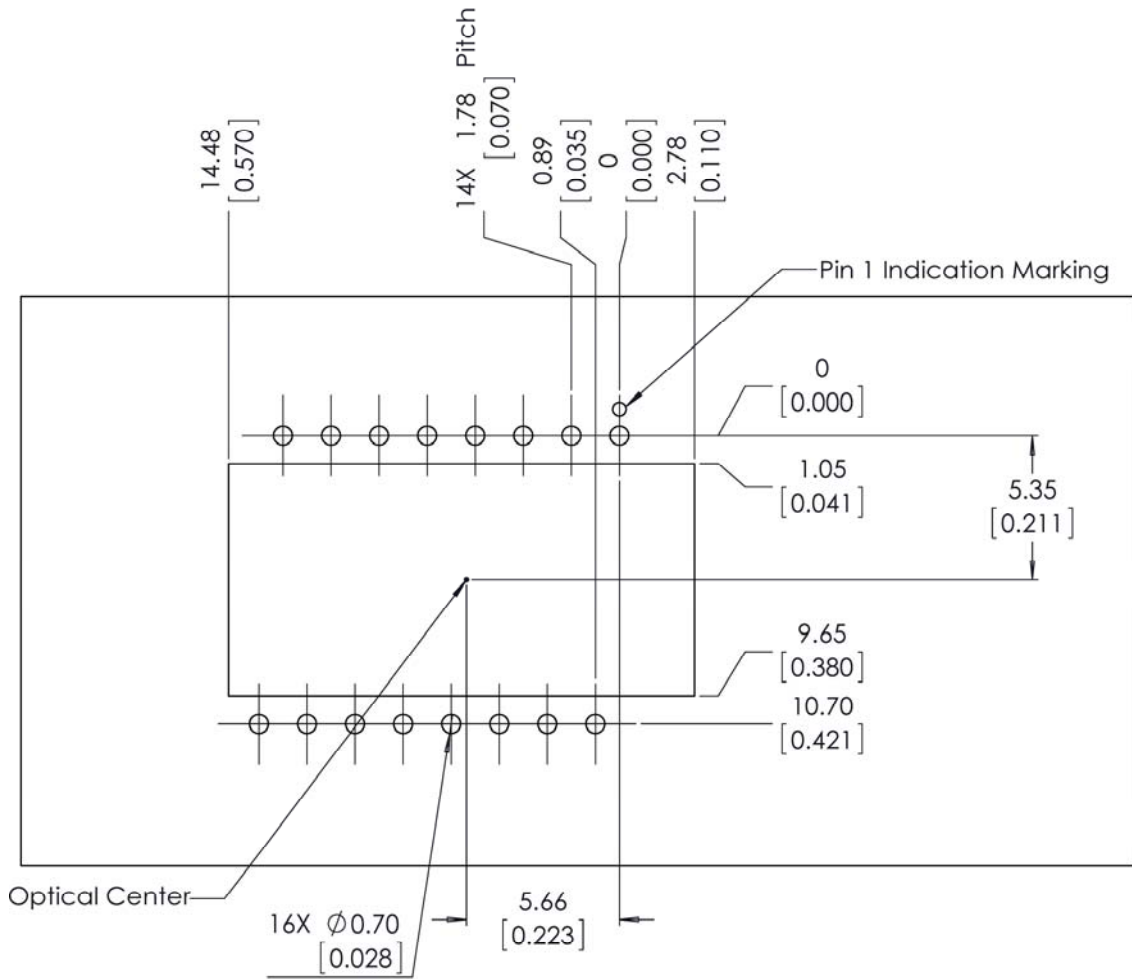

Figure 4. Recommended sensor orientation, mechanical cutouts and spacing (Top View)

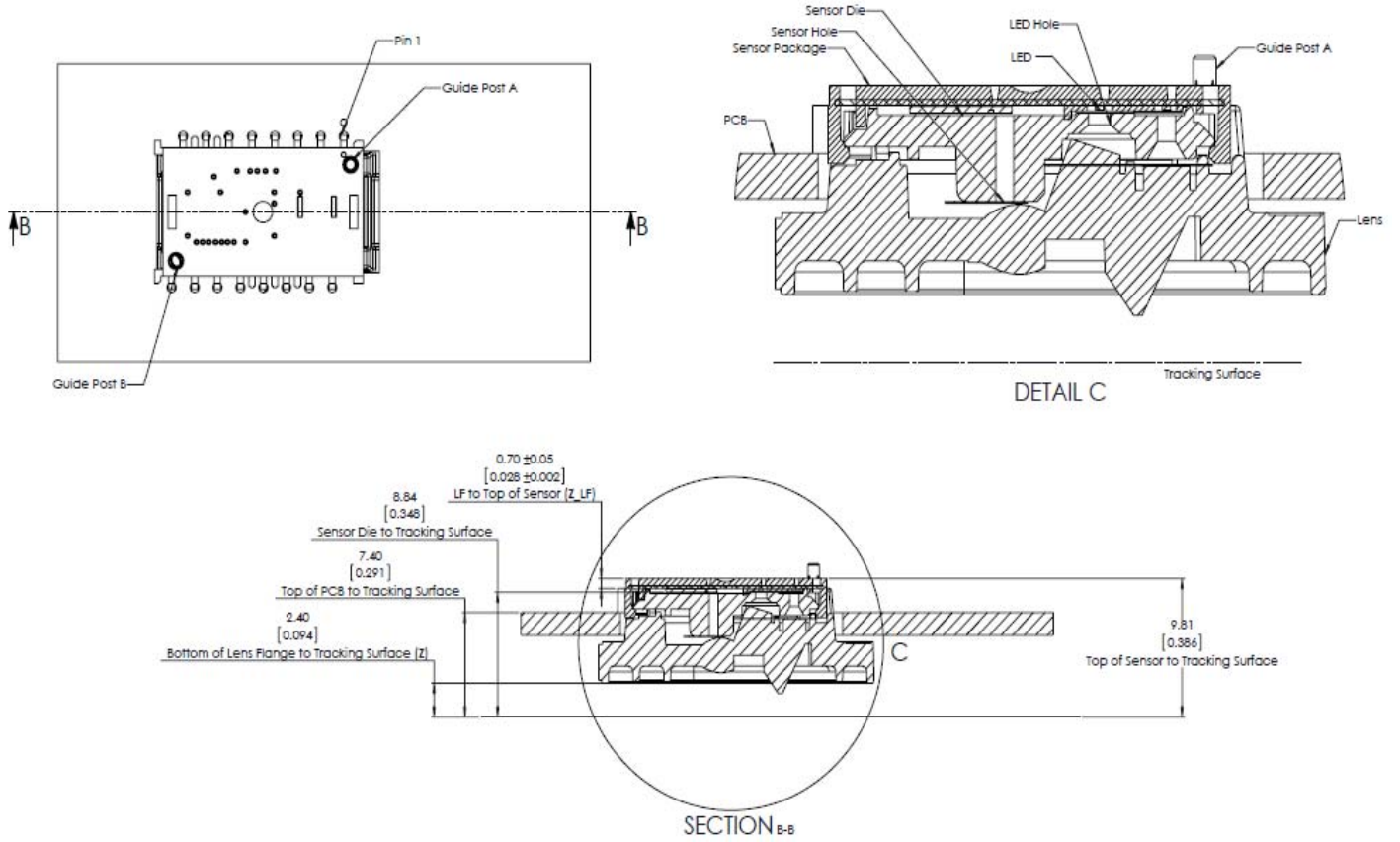

Figure 5. Assembly drawing of PMT9101 and distance from Lens reference plane to Tracking surface (Z)

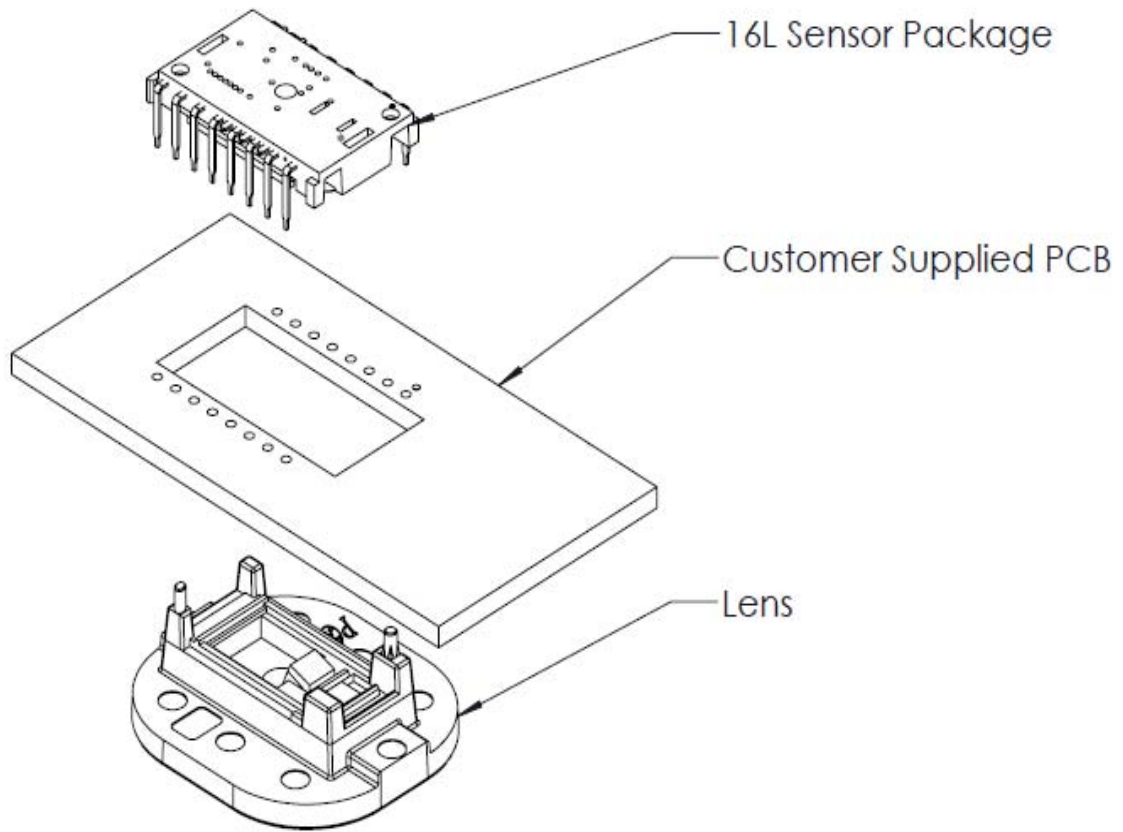

Figure 6. Exploded View of Assembly

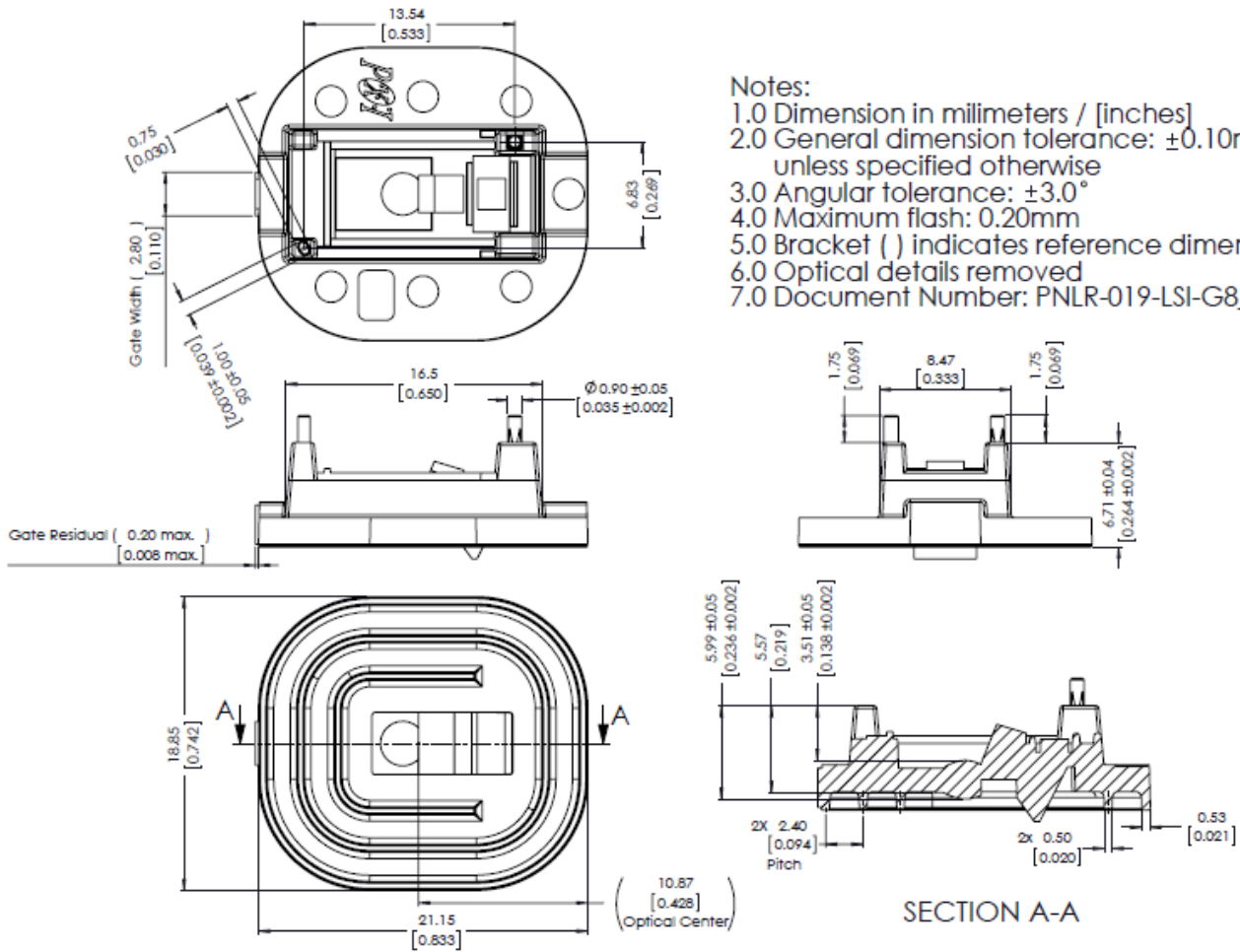

Figure 7. Lens Outline Drawing

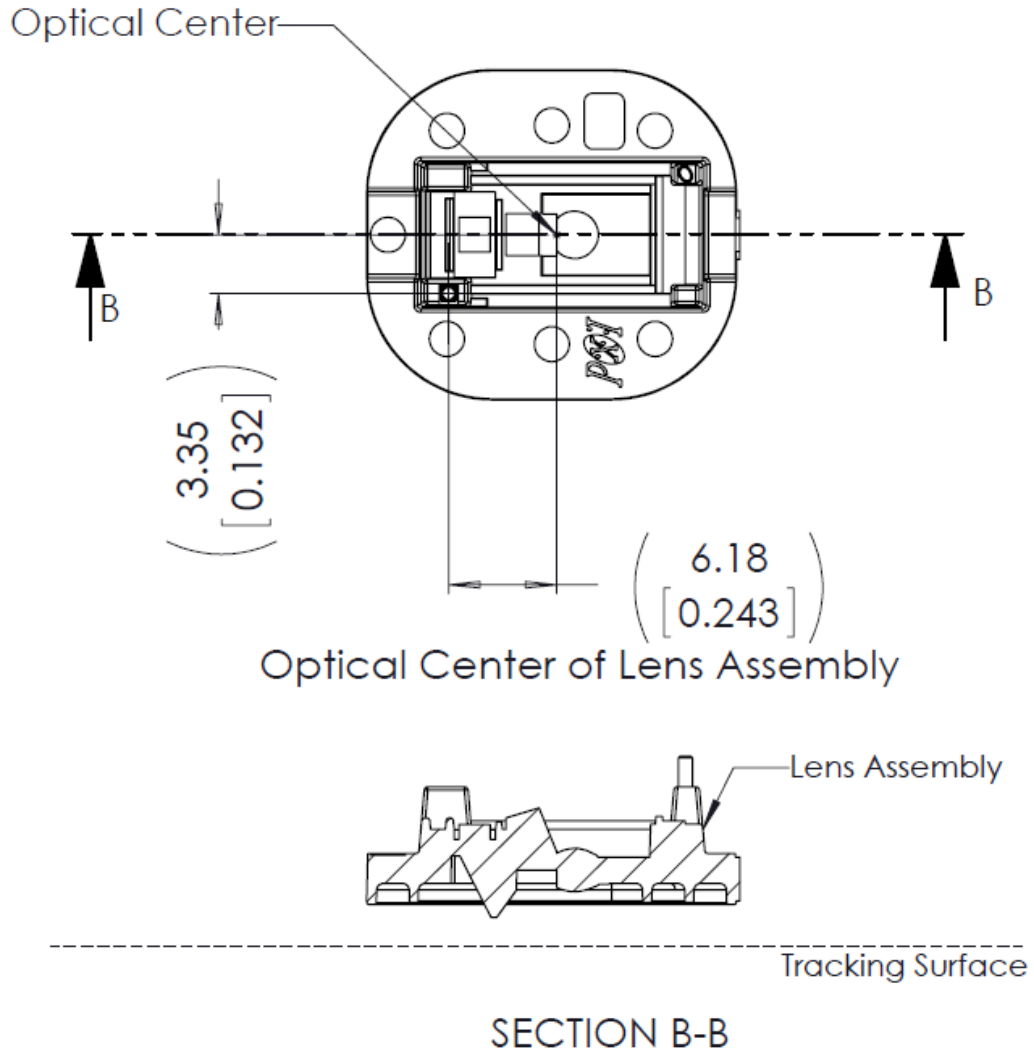
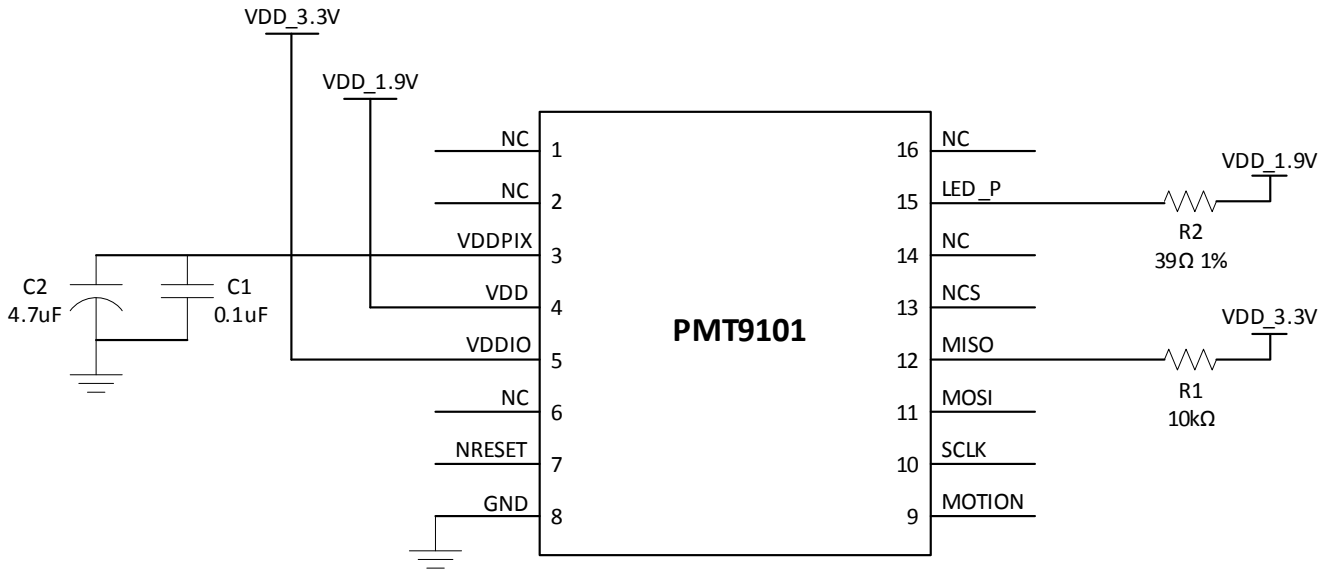

Figure 8. Cross section view of lens assembly

4.0 System Level Description

4.1 Reference Schematic



Note:

1. Capacitors must be placed near sensor.
2. Thicker trace path from VDD_1.9V to LED_P pin.
3. LED's orientation is placed towards the palm of a hand.

External Component Type	Value	Quantity
Capacitor	0.1uF, 4.7uF	2
Resistor	39Ω, 10kΩ	2

Figure 9. PMT9101 Reference Schematics

9.0 Registers

9.1 Registers List

PMT9101 registers are accessible via the serial port. The registers are used to read motion data and status as well as to set the device configuration.

Table 7. Register List

Address	Register Name	Access	Reset	Address	Register Name	Access	Reset
0x01	Product_ID	RO	0x01	0x13	SROM_Enable	WO	N/A
0x02	Motion	R/W	0x20	0x24	Observation	R/W	0x00
0x03	Delta_X_L	RO	0x00	0x25	Data_Out_Lower	RO	0x00
0x04	Delta_X_H	RO	0x00	0x26	Data_Out_Upper	RO	0x00
0x05	Delta_Y_L	RO	0x00	0x2A	SROM_ID	RO	0x00
0x06	Delta_Y_H	RO	0x00	0x2B	Min_SQ_Run	R/W	0x10
0x07	SQUAL	RO	0x00	0x2C	Pixel_Threshold	R/W	0x0A
0x08	Pixel_Sum	RO	0x00	0x2F	Config5	R/W	0x31
0x09	Maximum_Pixel	RO	0x00	0x3A	Power_Up_Reset	WO	N/A
0x0A	Minimum_Pixel	RO	0x00	0x3B	Shutdown	WO	N/A
0x0B	Shutter_Lower	RO	0x12	0x3E	Inverse_Product_ID	RO	0xFE
0x0C	Shutter_Upper	RO	0x00	0x42	Angle_Snap	R/W	0x00
0x0D	Control	R/W	0x02	0x50	Motion_Burst	R/W	0x00
0x0F	Config1	R/W	0x31	0x62	SROM_Load_Burst	WO	N/A
0x10	Config2	R/W	0x00	0x64	Pixel_Burst	RO	0x00
0x12	Frame_Capture	R/W	0x00				