

LM10075B

APPROVED DATE	<b>SHARP</b>	SPEC. No. LM10075B
		FILE No.
		PAGE : 19 pages including cover pages
ISSUED DATE : 2011. 8.11	SPECIFICATIONS	Display Division Business Solutions Promotion Group SHARP CORPORATION

DEVICE SPECIFICATIONS FOR

# TFT-LCD module

MODEL No.PN-MG605

CUSTOMER'S APPROVAL

DATE \_\_\_\_\_

BY \_\_\_\_\_

PRESENTED

Engineering Department

BY *Kenji Tanaka*

Date 2011. 8.11

RECORDS OF REVISION

MODEL NO.PN-MG605

SPEC No.	DATE	REVISED No.	SUMMARY		NOTE
			PAGE		
LM10075	2010. 12.21				Preliminary version
	2011.1. 21	1-2	8		Tsfc, [NOTE4] in Absolute Maximum Rating are added
	2011.2. 3	3	2 13 14 15 16 17		Revision "Weight" was determined. Pallet gross weight and Carton gross weight are added Test temperature and state( [Note] )are added Module Label is added and Material Label explanation is corrected. Packing form are changed Tolerance are added to Outline dimensions. Environmental Impact Substances Information are added.
	2011. 2. 4				authoritative version issued
	2011.6.16	4	13,15		Packing form has been changed
LM10075B	2011.8.11	5	8 9 13 14 15		ICC Max was added. Symbol is changed "LED VCC" →"VLED" VLED –Typ value was deleted. VLED –Min and Max values were added ILED was added. [NOTE 1 to 3] were revised. Shock test condition revised.(by "revised No.4") Module Label revised. Material Label revised. Packing form view revised.(Mis-description)

## 1. Application

This specifications applies to the color 60.0" TFT-LCD module PN-MG605.

\*This document are the proprietary product of SHARP CORPORATION("SHARP") and include materials protected under copyright of SHARP. Do not reproduce or cause any third party to reproduce them in any form or by any means, electronic or mechanical, for any purpose, in whole or in part, without the express written permission of SHARP.

\*The device listed in this document was designed and manufactured for use in information display.

\*In case of using the device for applications such as control and safety equipment for transportation(aircraft, trains, automobiles, etc. ), rescue and security equipment and various safety related equipment which require higher reliability and safety, take into consideration that appropriate measures such as fail-safe functions and redundant system design should be taken.

\*Do not use the device for equipment that requires an extreme level of reliability, such as aerospace applications, telecommunication equipment (trunk lines), nuclear power control equipment and medical or other equipment for life support.

\*SHARP assumes no responsibility for any damage resulting from the use of the device which does not comply with the instructions and the precautions specified in this document.

\*Contact and consult with a SHARP sales representative for any questions about this device.

\* SHARP takes no responsibility for any problems related to any intellectual property right of a third party resulting from the use of products.

## 2. Overview

This module is a color active matrix LCD module incorporating amorphous silicon TFT (Thin Film Transistor). It is composed of a color TFT-LCD panel, driver ICs, control circuit and LED back light system etc. Graphics and texts can be displayed on a 1366×RGB×768 dots panel with about 16.77 million colors by using 8bit LVDS (Low Voltage Differential Signaling) to interface and +12V of DC supply voltages.

And in order to improve the response time of LCD, this LCD module applies the Over Shoot driving (O/S driving) technology for the control circuit. In the O/S driving technology, signals are being applied to the Liquid Crystal according to a pre-fixed process as an image signal of the present frame when a difference is found between image signal of the previous frame and that of the current frame after comparing them.

With this technology, image signals can be set so that liquid crystal response completes within one frame. As a result, motion blur reduces and clearer display performance can be realized.

### 3. Mechanical Specifications

Parameter	Specifications	Unit
Display size	152.439(Diagonal)	cm
	60.0 (Diagonal)	inch
Active area	1328.7765 (H)×747.072 (V)	mm
Pixel format	1366 (H)×768 (V) (1 pixel=R+G+B dots)	pixel
Pixel pitch	0.97275 (H)×0.97275 (V)	mm
Pixel configuration	R, G, B vertical stripe	
Display mode	Normally black	
Unit outline dimensions (*1)	1335.9 (W)×754.2 (H)×104.2 (D)	mm
Weight	$\triangle_3$ 28.2±2.0	kg
Surface treatment	LR coating Hard coating: 2H and more	

(\*1)Outline dimensions are shown in Fig.3

## 4. Input Terminals

### 4-1. TFT-LCD panel driving

CN1 (Interface signals)

Using connectors : FX16S-41S-0.5SH (HIROSE)  
 Mating connectors : FX16M1-41P-HC (HIROSE)

Pin No.	Symbol	Function	Remark
1	Reserved	-	Must be OPEN
2	Reserved	-	Must be OPEN
3	Reserved	-	Must be OPEN
4	Reserved	-	Must be OPEN
5	GND	GND	
6	GND	GND	
7	GND	GND	
8	GND	GND	
9	LVDS_SEL	Select LVDS data order [Note 1]	Pull Up : (+3.3V)
10	Reserved	-	Must be OPEN
11	GND	GND	
12	RX0-	LVDS CH0 differential data input(-)	
13	RX0+	LVDS CH0 differential data input(+)	
14	GND	GND	
15	RX1-	LVDS CH1 differential data input(-)	
16	RX1+	LVDS CH1 differential data input(+)	
17	GND	GND	
18	RX2-	LVDS CH2 differential data input(-)	
19	RX2+	LVDS CH2 differential data input(+)	
20	GND	GND	
21	RXCLK-	LVDS Clock input(-)	
22	RXCLK+	LVDS Clock input(+)	
23	GND	GND	
24	RX3-	LVDS CH3 differential data input(-)	
25	RX3+	LVDS CH3 differential data input(+)	
26	GND	GND	
27	Reserved	-	Must be OPEN
28	Reserved	-	Must be OPEN
29	GND	GND	
30	Reserved	-	Must be OPEN
31	Reserved	-	Must be OPEN
32	Reserved	-	Must be OPEN
33	GND	GND	
34	GND	GND	
35	GND	GND	
36	GND	GND	
37	GND	GND	
38	Reserved	-	Must be OPEN
39	Reserved	-	Must be OPEN
40	Reserved	-	Must be OPEN
41	Reserved	-	Must be OPEN

[Note 1] LVDS Data order

LVDS_SEL		
Data	L(GND) [VESA]	H(3.3V) or Open [JEIDA]
TA0	R0(LSB)	R2
TA1	R1	R3
TA2	R2	R4
TA3	R3	R5
TA4	R4	R6
TA5	R5	R7(MSB)
TA6	G0(LSB)	G2
TB0	G1	G3
TB1	G2	G4
TB2	G3	G5
TB3	G4	G6
TB4	G5	G7(MSB)
TB5	B0(LSB)	B2
TB6	B1	B3
TC0	B2	B4
TC1	B3	B5
TC2	B4	B6
TC3	B5	B7(MSB)
TC4	NA	NA
TC5	NA	NA
TC6	DE(*)	DE(*)
TD0	R6	R0
TD1	R7	R1
TD2	G6	G0
TD3	G7	G1
TD4	B6	B0
TD5	B7	B1
TD6	NA	NA

NA: Not Available

(\*)Since the display position is prescribed by the rise of DE(Display Enable)signal, please do not fix DE signal during operation at "High".

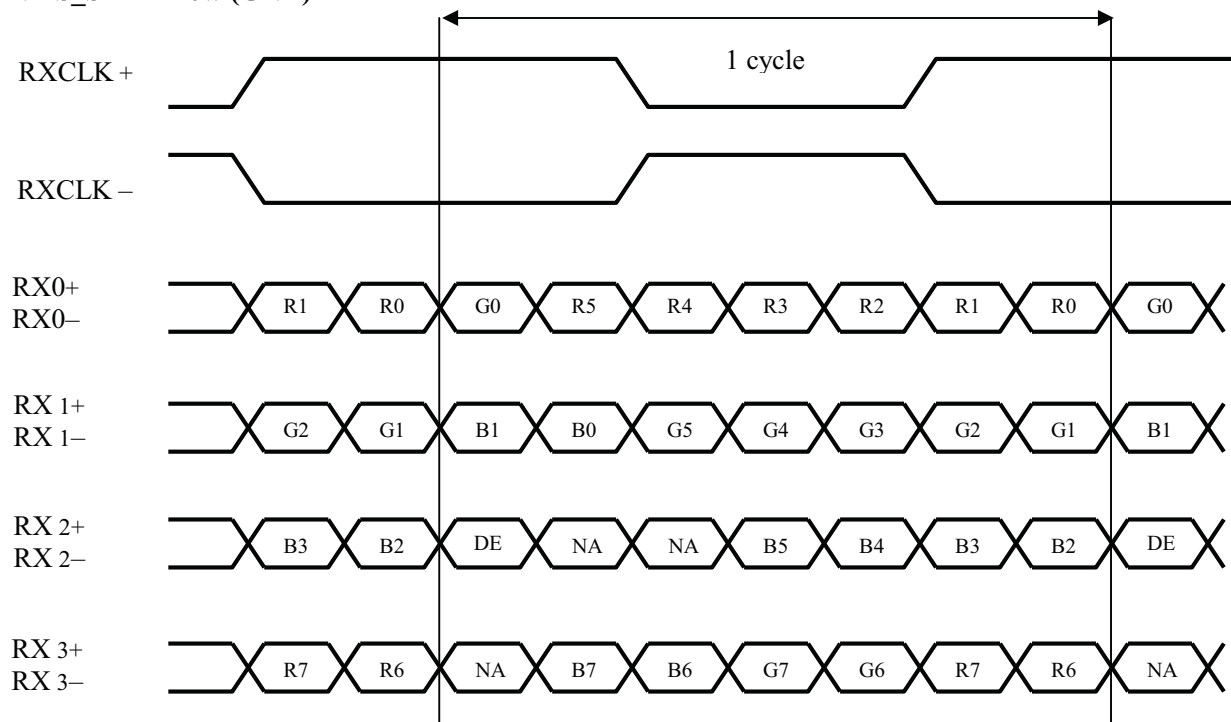
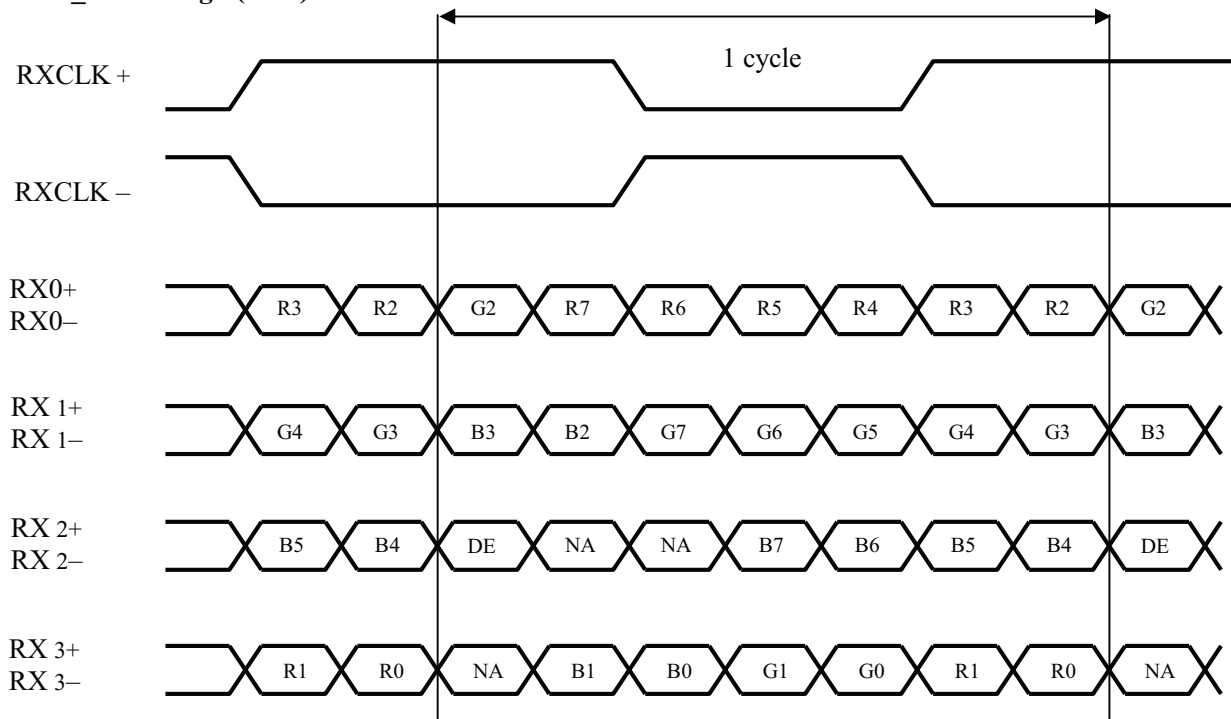
**LVDS\_SEL = Low (GND)****LVDS\_SEL = High (3.3V) or OPEN**

DE: Display Enable, NA: Not Available (Fixed Low)

CN2 (+12V DC power supply)

Using connectors : SM05B-PASS (JST)  
 Mating connectors : PAP-05V-S (JST)

Pin No.	Symbol	Function	Remark
1	VCC	+12V Power Supply	
2	VCC	+12V Power Supply	
3	GND	GND	
4	GND	GND	
5	NC		

LED HARNESS1 - 6 (LED Power supply)

Using connectors : 51284-1000 or 51284-1001 (MOLEX)  
 Mating connectors : 55883-1090 or 55883-1091 (MOLEX)

Pin No.	Symbol	Function	Remark
1	LED 1A	LED Anode1	
2	LED 2A	LED Anode2	
3	LED 3A	LED Anode3	
4	LED 4A	LED Anode4	
5	LED 5A	LED Anode5	
6	LED 1K	LED Cathode1	
7	LED 2K	LED Cathode2	
8	LED 3K	LED Cathode3	
9	LED 4K	LED Cathode4	
10	LED 5K	LED Cathode5	

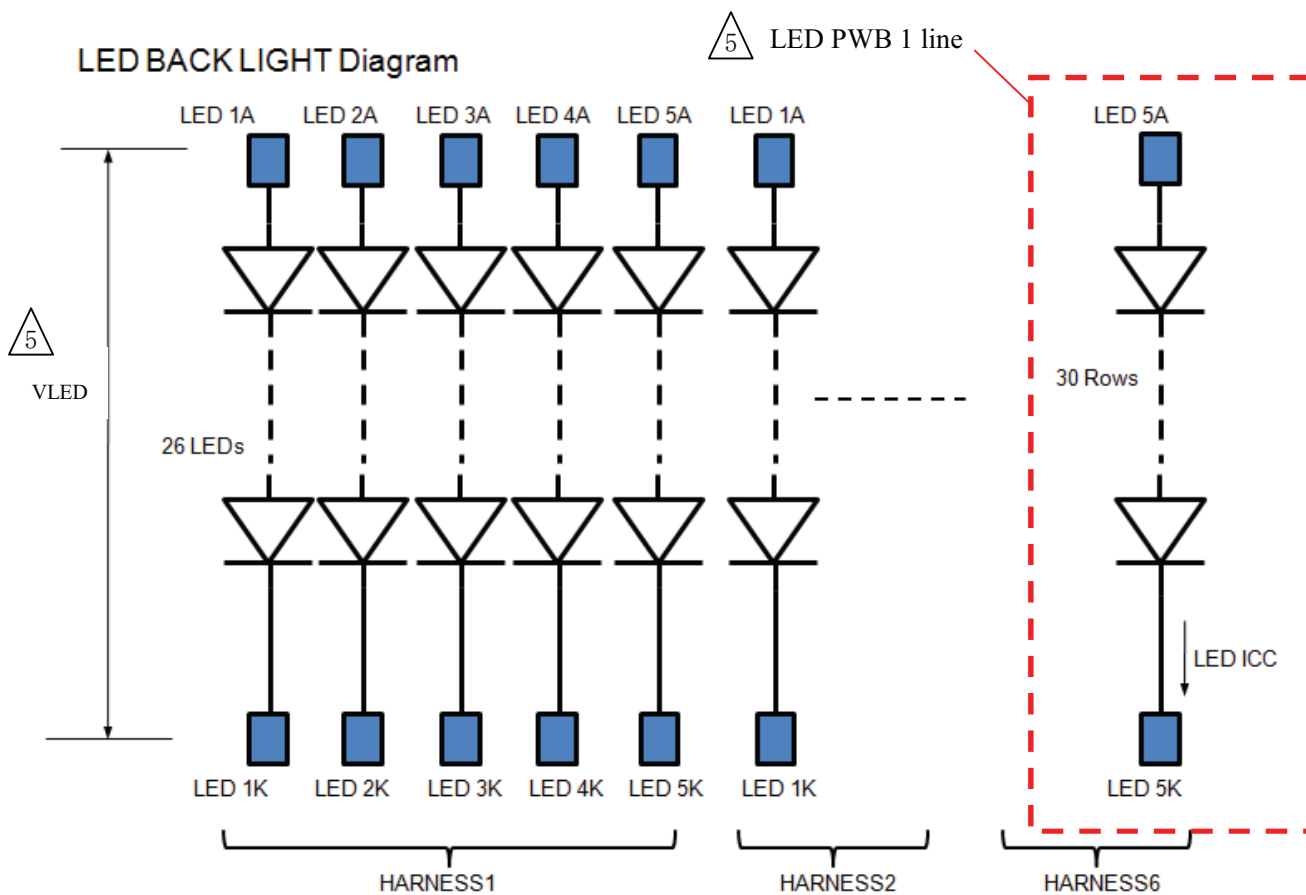



## 4-2. Interface block diagram

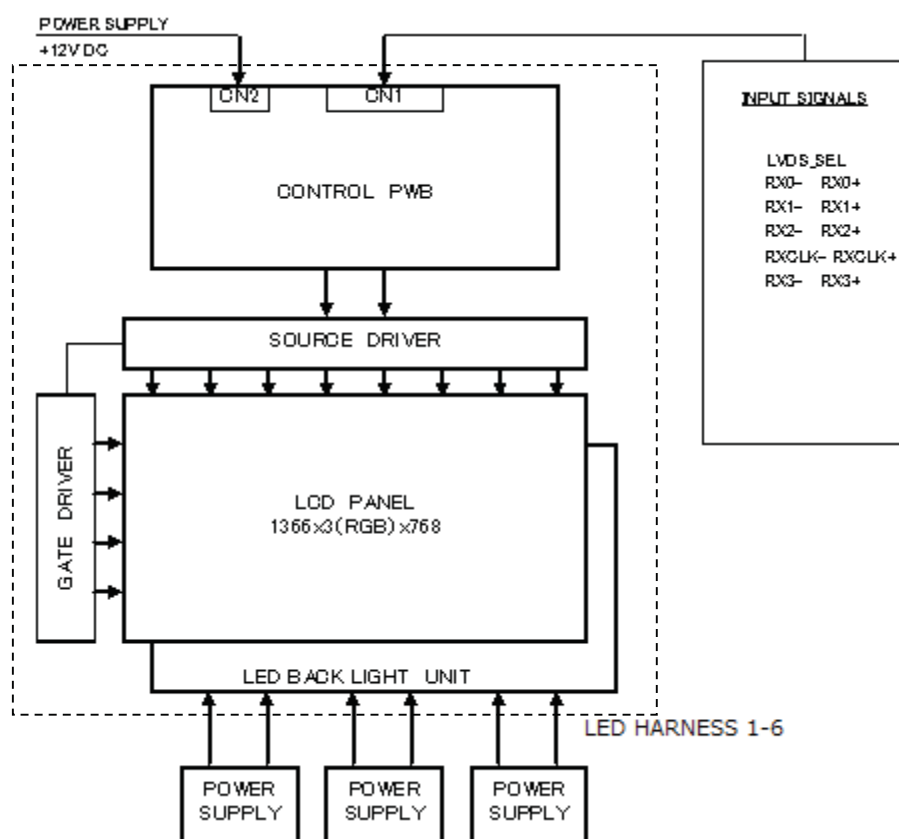

## 4.3. The back light system characteristics

The back light system is direct type with 780 LEDs.

The characteristics of the LED are shown in the following table.

Item	Symbol	Min.	Typ.	Max.	Unit	Remarks
Life time	$T_L$	—	(37000)	—	Hour	[NOTE]

[NOTE]

- LED life time is defined as the time when brightness become 70% of the original value in the continuous operation under the condition of  $T_a=25^\circ\text{C}$

## 5. Absolute Maximum Rating

Parameter	Symbol	Condition	Ratings	Unit	Remark
Input Voltage (for Control)	$V_I$	$T_a=25^\circ\text{C}$	-0.3 ~ 3.6	V	[NOTE1]
12V supply voltage (for Control)	VCC	$T_a=25^\circ\text{C}$	0 ~ 14	V	
Forward current (for LED)	$I_F$	$T_a=25^\circ\text{C}$	80	mA	$T_c \leq 74.1^\circ\text{C}$
Reverse voltage (for LED)	$V_R$	$T_a=25^\circ\text{C}$	130	V	Maximum 5V for each LED
Storage temperature	$T_{\text{stg}}$		-25 ~ 60	$^\circ\text{C}$	
Operation temperature (Ambient)	$T_{\text{opa}}$		0 ~ 50	$^\circ\text{C}$	[NOTE2]
LED terminal temperature	$T_c$		0 ~ 80	$^\circ\text{C}$	[NOTE3], [NOTE4]
 LCD surface temperature	$T_{\text{sf}}c$		0 ~ 60	$^\circ\text{C}$	[NOTE4]

[NOTE1] LVDS\_SEL

[NOTE2] Humidity 95% RH Max ( $T_a \leq 40^\circ\text{C}$ )

Maximum wet-bulb temperature should be less than  $40^\circ\text{C}$ . ( $T_a > 40^\circ\text{C}$ )

No condensation.

[NOTE3] LED terminal temperature should be measured on the LED PWBs.

 [NOTE4]  $T_c$  and  $T_{\text{sf}}c$  in operation must be in the above range on any condition.

## 6. Electrical Characteristics

### 6.1 Control driving

Parameter		Symbol	Min.	Typ.	Max	Unit	Remark
 +12V supply voltage	Supply voltage	VCC	11.4	12.0	12.6	V	
	Current dissipation	ICC		(1)	1.5	A	
Permissible input ripple voltage		$V_{\text{RP}}$	—	—	100	mV	
Differential input threshold voltage	High	$V_{\text{TH}}$	1.3	—	1.8	V	[NOTE2]
	Low	$V_{\text{TL}}$	0.6	—	1.1	V	
Differential input leak current		$I_{\text{Iz}}$	-10		+10	$\mu\text{A}$	
Input Low voltage		$V_{\text{IL}}$	—	—	1.0	V	[NOTE1]
Input High voltage		$V_{\text{IH}}$	2.5	—	3.3	V	
Input leak current (Low)		$I_{\text{IL1}}$	—	—	400	$\mu\text{A}$	$V_I=0\text{V}$ [NOTE1]
Input leak current (High)		$I_{\text{IH1}}$	—	—	TBD	$\mu\text{A}$	$V_I=3.3\text{V}$ [NOTE1]
Terminal resistor		$R_T$	—	100	—	$\Omega$	

[NOTE 1] LVDS\_SEL(10k $\Omega$ pull-up)

[NOTE 2] RXCLK $\pm$ , RX0 $\pm$ , RX1 $\pm$ , RX2 $\pm$ , RX3 $\pm$

## 5 6.2 LED driving

Parameter	Symbol	Min.	Typ.	Max	Unit	Remark
LED Current	LED ICC	—	(45)	60	mA	Each pin of LED HARNESS1 - 6 [NOTE1]
Operating Current	ILED	—	(1.35)	1.8	A	LED ICC × 30 lines [NOTE2]
Operating Voltage	VLED	256	—	290	V	ILED=1.8A [NOTE3]

[NOTE 1] Provided by the constant-current power supply.

LED current (LED ICC) is the value of LED PWB 1 line.

(refer to “LED BACK LIGHT DIAGRAM” for “LED PWB 1 line”)

Please control so that LED current value never exceeds MAX value.

Please keep the temperature of the terminal of LED 80°C or less.

LED Brightness should be controlled by PWM method as shown below.

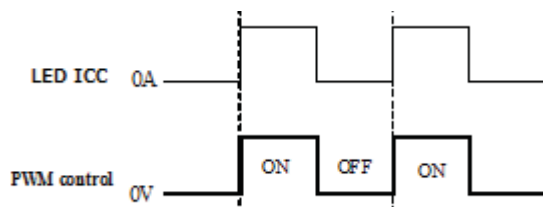

[NOTE 2] ILED is the total value of LED ICC 30 lines.

[NOTE 3] VLED is a potential difference between the anode and the cathode of LED PWB 1 line.

(refer to “LED BACK LIGHT DIAGRAM” for “LED PWB 1 line”)

Measurement after 100ms has passed since power supply was turned on.

## 6.3 Timing characteristics of input signals

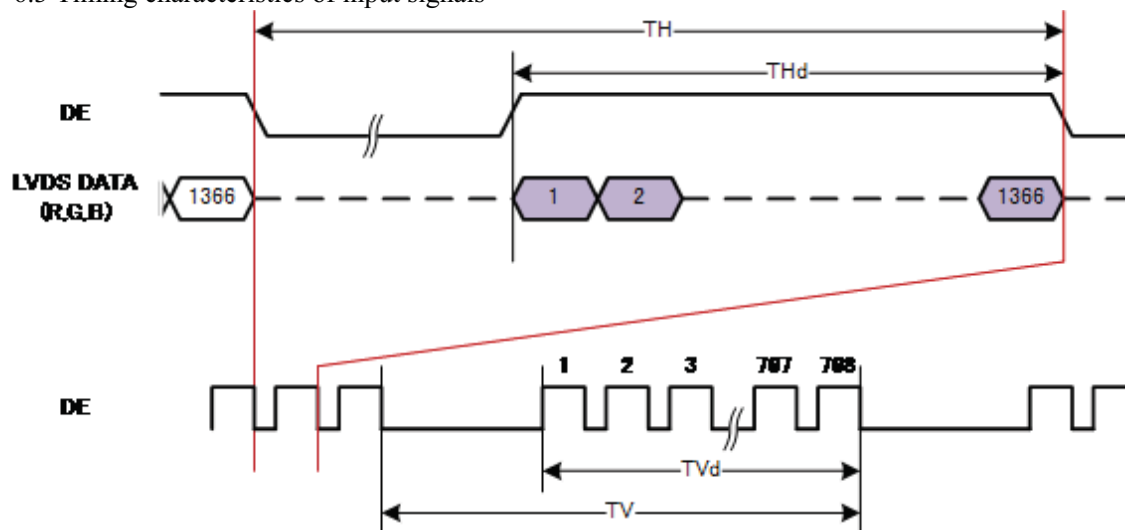

Parameter	Symbol	Min.	Typ.	Max.	单位	備考	
Clock	Frequency	1/Tc	83		MHz		
Data Enable	Horizontal period	TH	1696		clock		
	Horizontal period (High)	THd	20.43		μ sec		
	Horizontal period (Low)	THl	—	1366	—	clock	
	Vertical period	TV		806		line	
	Vertical period (High)	TVd	—	768	—	line	

Fig.1 Timing characteristics of input signals

## 7. Optical characteristics

Ta=25°C, VCC=12.0V, LED ICC=45mA, LED PWM Burst= 99.97% , Timing :60Hz (typ.value)

Parameter	Symbol	Condition	Min.	Typ.	Max.	Unit	Remark
Contrast ratio	CRn	$\theta=0^\circ$		2400		—	[NOTE2,4]
Luminance of white	x	$\theta=0^\circ$		0.292			[NOTE4]
	y			0.307			
Luminance of red	x			0.656			
	y			0.337			
Luminance of green	x			0.306			
	y			0.641			
Luminance of blue	x		0.152				
	y		0.065				
Viewing angle range	Horizontal	$\theta_{21}, \theta_{22}$	CR>10	88		deg	[NOTE1,4]
	Vertical	$\theta_{11}, \theta_{12}$		88		deg	
Luminance	$Y_L$	White		(700)		cd/m <sup>2</sup>	
Luminance uniformity	$\delta w$	$\theta=0^\circ$		(1.25)			[NOTE6]
Response time	$\tau$	$\theta=0^\circ$		6		ms	[NOTE3,4,5]

Measurement condition : Set the LED PWM Burst to maximum

The measurement shall be executed 60 minutes after lighting at rating.

[Note]The optical characteristics are measured using the following equipment.

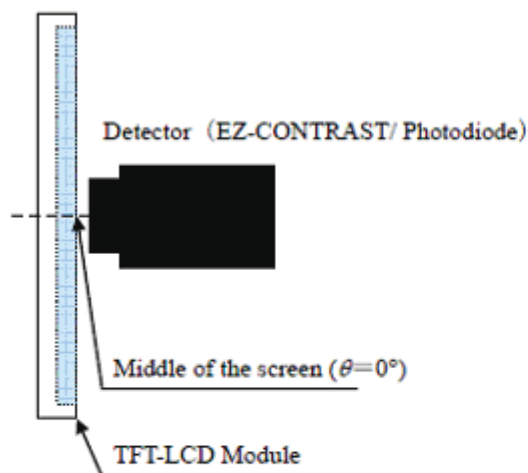

Fig.4-1 Measurement of viewing angle range and Response time.

Viewing angle range: EZ-CONTRAST  
Response time: Photodiode

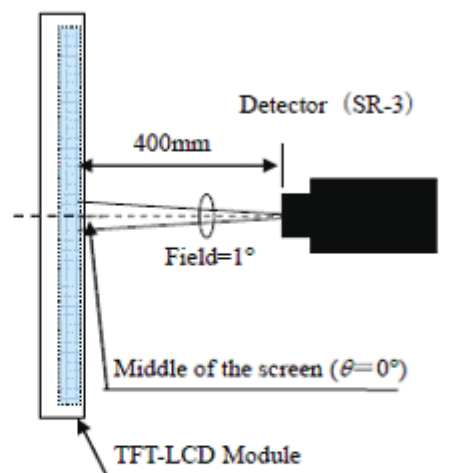
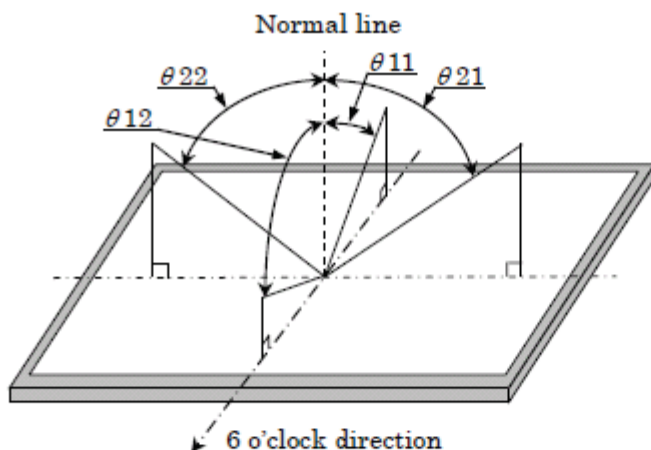

Fig.4-2 Measurement of Contrast, Luminance, Chromaticity.

[Note 1]Definitions of viewing angle range :



[Note 2]Definition of contrast ratio :

The contrast ratio is defined as the following.

$$\text{Contrast Ratio} = \frac{\text{Luminance (brightness) with all pixels white}}{\text{Luminance (brightness) with all pixels black}}$$

[Note 3]Definition of response time

The response time ( $\tau_d$  and  $\tau_r$ ) is defined as the following figure and shall be measured by switching the input signal for “any level of gray (0%, 25%, 50%, 75% and 100%)” and “any level of gray (0%, 25%, 50%, 75% and 100%)”.

	0%	25%	50%	75%	100%
0%		tr:0%-25%	tr:0%-50%	tr:0%-75%	tr:0%-100%
25%	td: 25%-0%		tr: 25%-50%	tr:25%-75%	tr: 25%-100%
50%	td: 50%-0%	td: 50%-25%		tr: 50%-75%	tr: 50%-100%
75%	td: 75%-0%	td: 75%-25%	td: 75%-50%		tr: 75%-100%
100%	td: 100%-0%	td: 100%-25%	td: 100%-50%	td:100%-75%	

t\*:x-y...response time from level of gray(x) to level of gray(y)

$$\tau_r = \Sigma(\text{tr}:x-y)/10, \tau_d = \Sigma(\text{td}:x-y)/10$$

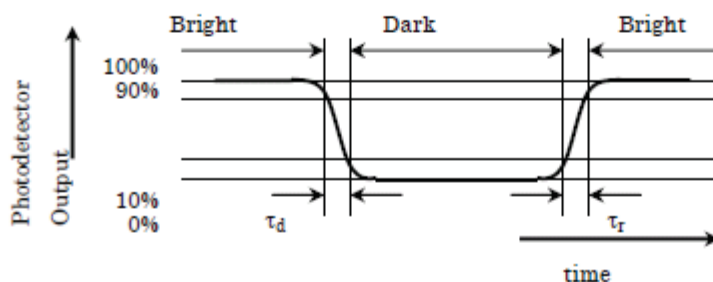

[Note 4]This shall be measured at center of the screen.

[Note 5] This value is valid when O/S driving is used at typical input time value.

[Note 6] Definition of white uniformity ;

White uniformity is defined as the following with five measurements. (A~E)

$$\delta_w = \frac{\text{Maximum luminance of five points (brightness)}}{\text{Minimum luminance of five points (brightness)}}$$

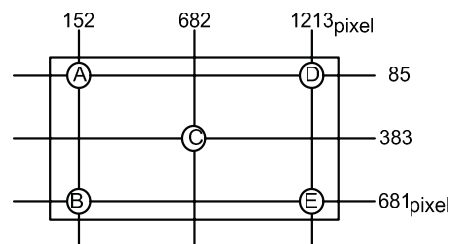

## 8. Handling Precautions of the LCD module

- a) Be sure to turn off the power supply when inserting or disconnecting the cable.
- b) Be sure to design the cabinet so that the LCD module can be installed without any extra stress such as warp or twist.
- c) Since the front polarizer is easily damaged, pay attention not to scratch it.
- d) Since long contact with water may cause discoloration or spots, wipe off water drop immediately.
- e) When the panel surface is soiled, wipe it with absorbent cotton or other soft cloth.
- f) Since the panel is made of glass, it may break or crack if dropped or bumped on hard surface. Handle with care.
- g) Since CMOS LSI is used in this LCD module, take care of static electricity and take the human earth into consideration when handling.
- h) The LCD module has some printed circuit boards (PCBs) on the back side, take care to keep them from any stressor pressure when handling or installing the module; otherwise some of electronic parts on the PCBs may be damaged.
- i) Observe all other precautionary requirements in handling components.
- j) When some pressure is added onto the module from rear side constantly, it causes display non-uniformity issue, functional defect, etc.. So, please avoid such design.
- k) When giving a touch or hit the panel in supplying power, it may cause some kinds of degradation. In that case, once turn off the power supply, and turn on after several seconds again, and that is disappear.
- l) When handling LCD modules or assembling them into cabinets, please be noted that long-term storage in the environment of oxidization or deoxidization gas and the use of such materials as reagent, solvent, adhesive, resin, etc. which generate these gasses, may cause corrosion and discoloration of the LCD modules.
- m) Make sure that the LCD module is operated within specified temperature and humidity. Measures to avoid dust, water, vibration, and heat radiation, etc. are required with cabinet or other way. And image retention may occur if same fixed pattern is displayed for a long time. In some cases, it may not disappear.  
Please consider the design and operating environment

## 9. Packing form

- a) Quantity of LCD Modules in one pallet: 4 LCD Modules  $\triangle_4$   
 $\triangle_4$  b) Piling number of pallet: 1 maximum  
 c) Pallet size: 1480 (W)  $\times$  575 (D)  $\times$  1040(H) mm  $\triangle_4$   
 $\triangle_3$  d) Pallet gross weight : approximately 137.8 kg  $\triangle_4$   
 $\triangle_3$  e) Packing Form are shown in Fig. 2  
 [Note] Pallet transportation is required in mass transportation like Sea, Air, Track, Train or others.

## 10. Reliability test item

No.	Test item	Condition
1	High temperature storage test (in package)	Ta=60 °C 48h
2	Low temperature storage test (in package)	Ta=-25 °C 48h
3	High temperature and high humidity operation test	Ta=40 °C ; 95%RH 48h (Conditions : Assembled in to the SHARP Unit(PN-V601)/ No condensation)
4	High temperature operation test	Ta=40 °C 240h (Conditions :Assembled in to the SHARP Unit(PN-V601)/ No condensation)
5	Low temperature operation test	Ta=0 °C (Conditions : Assembled in to the SHARP Unit(PN-V601)/ No condensation/Operation test after five hours power-off)
6	Vibration test (non-operation / in package) $\triangle_3$	Frequency : 10~50Hz/Acceleration: (9.8 m/s <sup>2</sup> ) Sweep time : 3 minutes Test period : 1.5 hours (1 hour for direction of Z, 15min for each direction of X, Y,) Ta=25 $\pm$ 2 °C
7	Shock test (non-operation / in package) $\triangle_5$	Fall 200mm in height /4 ridges/ (Drop test with support of the other side ridge) Ta=25 $\pm$ 2 °C
8	ESD (operation) $\triangle_3$	At the following conditions, it is a thing without incorrect operation and destruction. (1)Contact electric discharge +/-4kV (2)Non-contact electric discharge +/-8kV Electric discharge point : bezel screws/operation panel Conditions : 150pF, 330ohm Ta=25 $\pm$ 2 °C , Assembled in to the SHARP Unit(PN-V601)

[Result evaluation criteria]

Under the display quality test condition with normal operation state, there shall be no change, which may affect practical display function.

- $\triangle_3$  [Note]  
 In display quality test, LCD module should be put with the surface perpendicular to a level surface like following fig.

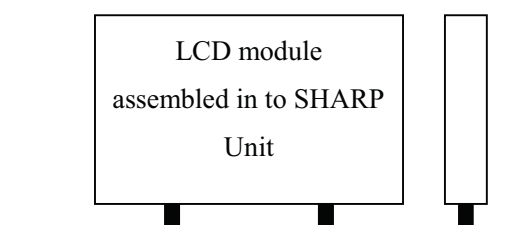

## 10. Others

- 3) 1)-1 Module Label ;  
Module Label is stuck on the back side of the module.

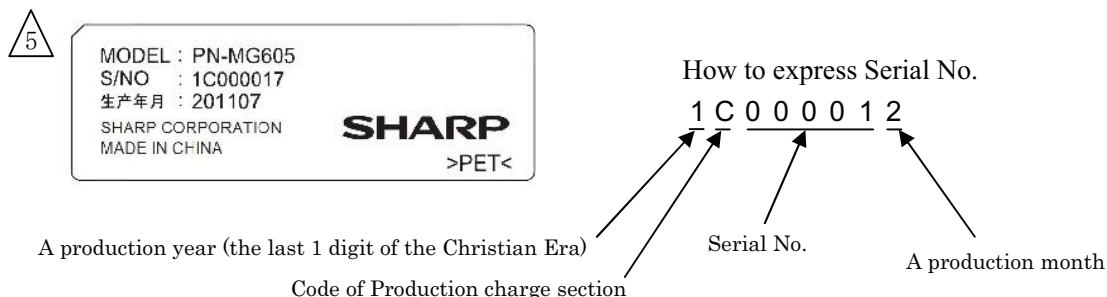

- 3) 1)-2 Material Label ;  
Material Label is stuck on the back side of the module.

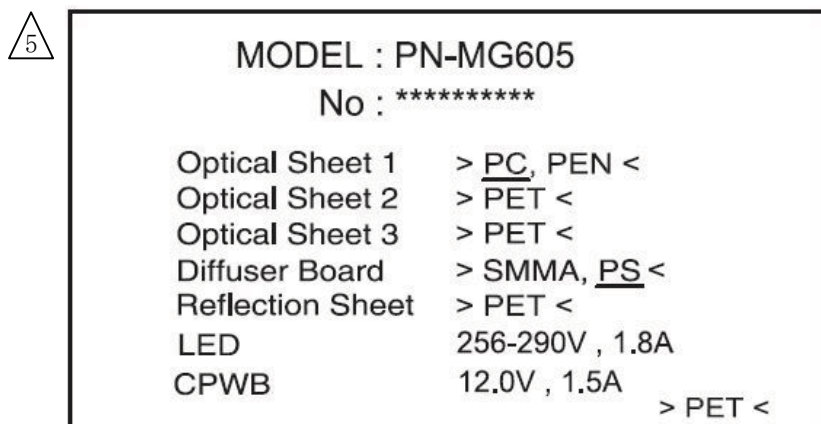

- 2) Disassembling the module can cause permanent damage and should be strictly avoided.
- 3) Please be careful since image retention may occur when a fixed pattern is displayed for a long time.
- 4) Lead-free soldering is applied.
- 5) The chemical compound, which causes the destruction of ozone layer, is not being used.
- 6) Rust on the module is not taken up a problem.
- 7) Ventilation and cooling measurement should be taken to keep away from high temperature.

## 11. Carton storage condition

Temperature	0 °C to 40 °C
Humidity	95%RH or less
Reference condition	: 20 °C to 35 °C, 85%RH or less (summer)
	: 5 °C to 15 °C, 85%RH or less (winter)
Sunlight	Be sure to keep the LCD module away from direct sunlight.
Atmosphere	Harmful gas, such as acid and alkali which bites electronic components and/or wires must not be detected.
Notes	Be sure to keep the LCD module in the carton on palette, don't put it on floor. Please take care of ventilation in storehouse and around cartons, and control changing temperature is within limits of natural environment
Storage life	1 year



3 12. Packing form

4

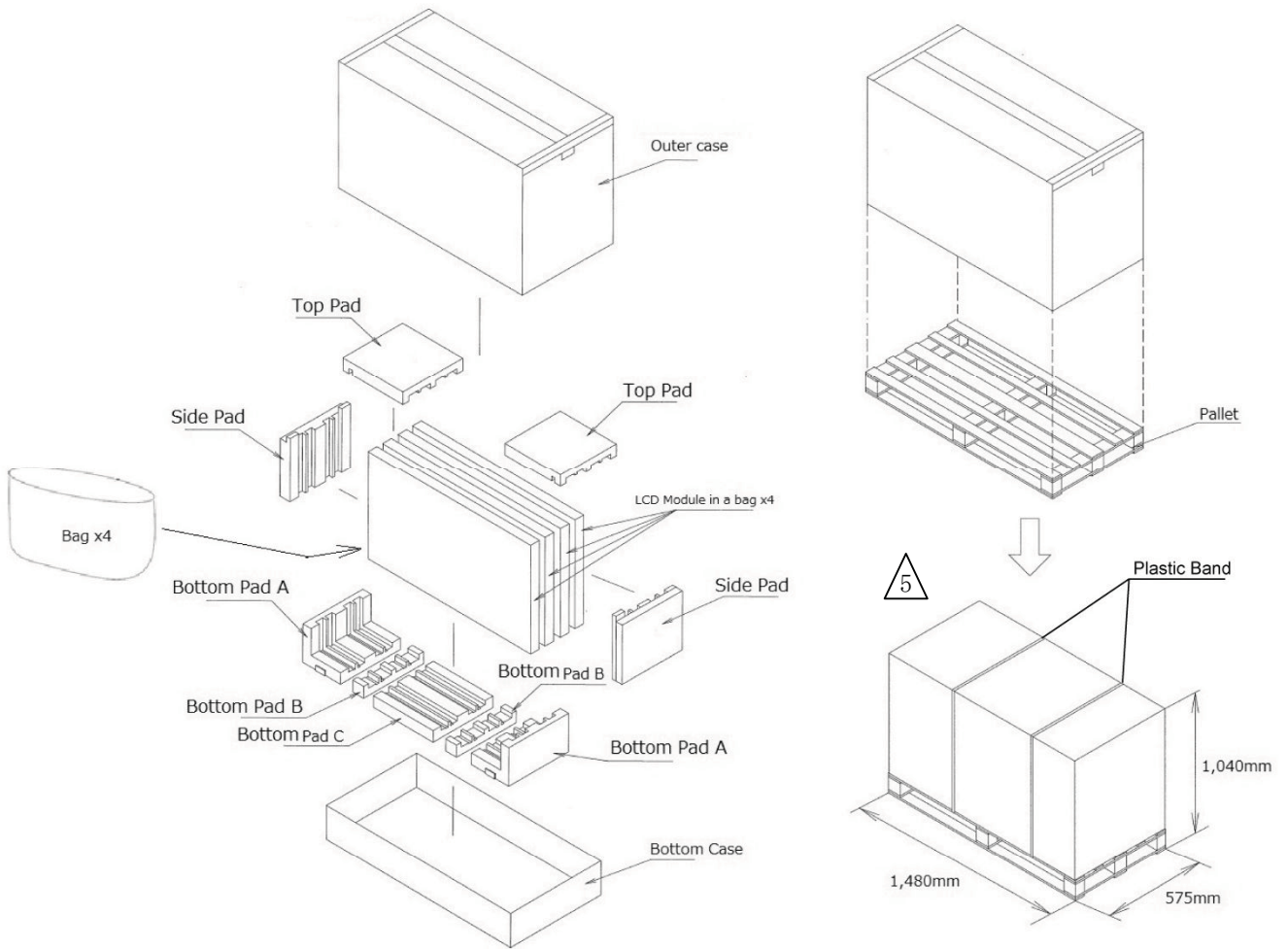

Fig.2 PACKING FORM

3 13. Outline dimensions

Tolerance	
description	
TD 0	±0.50
OVER TO 15 HIG.	±0.70
OVER TO 100 HIG.	±1.00
OVER TO 200 HIG.	±1.50

Unit : mm

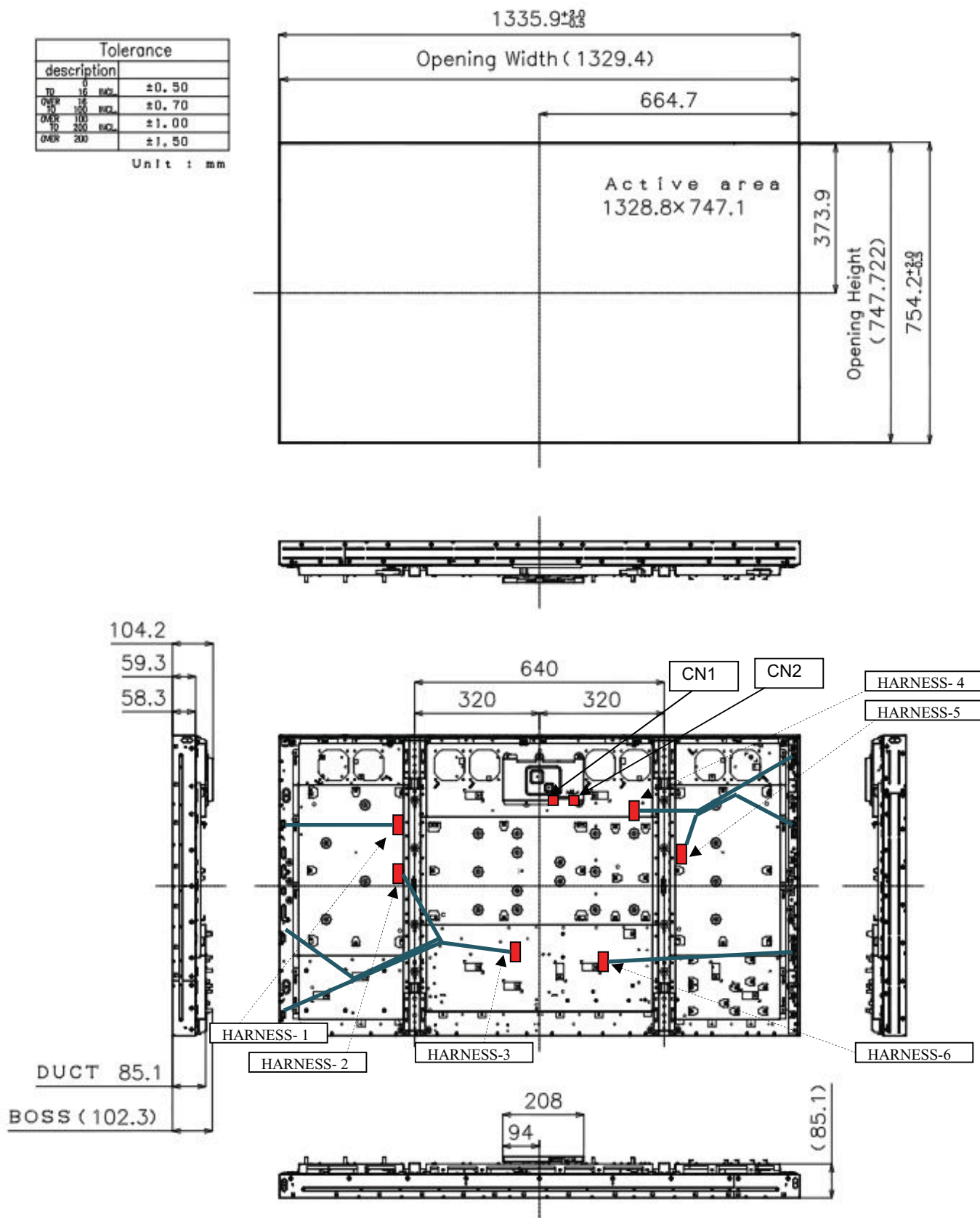

Fig.3 Outline dimensions

### 14. Environmental Impact Substances Information

#### 产品中有毒有害物质或元素的名称及含量

部件名称	有毒有害物质或元素					
	铅 (Pb)	汞 (Hg)	镉 (Cd)	六价铬 (Cr(VI))	多溴联苯 (PBB)	多溴二苯醚 (PBDE)
液晶组件 (LCD module)	×	○	○	○	○	○
<p>○：表示该有毒有害物质在该部件所有均质材料中的含量均在SJ/T 11363-2006 标准规定的限量要求以下。</p> <p>×：表示该有毒有害物质至少在该部件的某一均质材料中的含量超出SJ/T 11363-2006 标准规定的限量要求。</p>						