



PN2222A

NPN SILICON TRANSISTOR

NPN GENERAL PURPOSE AMPLIFIER

■ FEATURES

* This device is for use as a medium power amplifier and switch requiring collector currents up to 500mA.

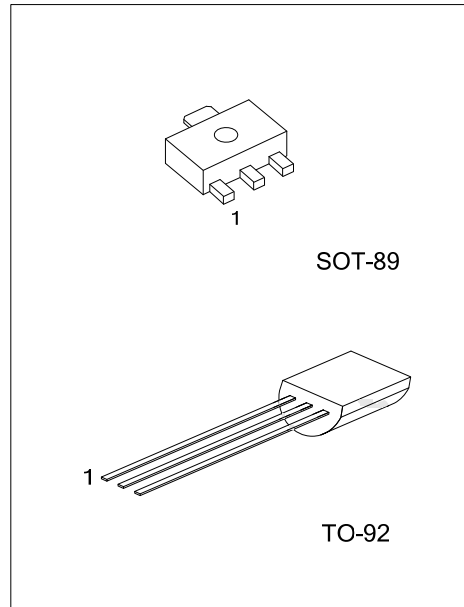

■ ORDERING INFORMATION

Ordering Number		Package	Pin Assignment			Packing
Lead Free	Halogen Free		1	2	3	
PN2222AL-AB3-R	PN2222AG-AB3-R	SOT-89	B	C	E	Tape Reel
PN2222AL-T92-R	PN2222AG-T92-R	TO-92	E	B	C	Tape Reel
PN2222AL-T92-B	PN2222AG-T92-B	TO-92	E	B	C	Tape Box
PN2222AL-T92-K	PN2222AG-T92-K	TO-92	E	B	C	Bulk

PN2222AL-AB3-R 	(1) Packing Type (2) Package Type (3) Lead Plating	(1) R: Tape Reel, B: Tape Box, K: Bulk (2) AB3: SOT-89, T92: TO-92 (3) L: Lead Free, G: Halogen Free
--------------------	--	--

PN2222A

NPN SILICON TRANSISTOR

■ ABSOLUTE MAXIMUM RATING ($T_A=25^{\circ}\text{C}$, unless otherwise specified)

PARAMETER		SYMBOL	RATINGS	UNIT
Collector-Base Voltage		V_{CBO}	75	V
Collector-Emitter Voltage		V_{CEO}	40	V
Emitter-Base Voltage		V_{EBO}	6	V
Collector Current		I_C	0.6	A
Total Device Dissipation	SOT-89	P_C	1.2	W
	TO-92		0.6	
Junction Temperature		T_J	+150	$^{\circ}\text{C}$
Storage Temperature		T_{STG}	-55 ~ +150	$^{\circ}\text{C}$

Note: Absolute maximum ratings are those values beyond which the device could be permanently damaged. Absolute maximum ratings are stress ratings only and functional device operation is not implied.

■ THERMAL DATA ($T_A=25^{\circ}\text{C}$, unless otherwise noted)

PARAMETER		SYMBOL	RATINGS	UNIT
Junction to Ambient	SOT-89	θ_{JA}	104	$^{\circ}\text{C}/\text{W}$
	TO-92		200	
Junction to Case	SOT-89	θ_{JC}	38	$^{\circ}\text{C}/\text{W}$
	TO-92		80	

■ ELECTRICAL CHARACTERISTICS (T_A=25°C, unless otherwise specified)

PARAMETER	SYMBOL	TEST CONDITIONS	MIN	TYP	MAX	UNIT
OFF CHARACTERISTICS						
Collector-Base Breakdown Voltage	BV _{CBO}	I _C =10μA, I _E =0	75			V
Collector-Emitter Breakdown Voltage	BV _{CEO}	I _C =10mA, I _B =0	40			V
Emitter-Base Breakdown Voltage	BV _{EBO}	I _E =10μA, I _C =0	6			V
Collector Cut-off Current	I _{CEO}	V _{CE} =60V, V _{EB(OFF)} =3.0V			10	nA
Collector Cut-Off Current	I _{CBO}	V _{CB} =60V, I _E =0			0.01	μA
Emitter Cut-Off Current	I _{EBO}	V _{EB} =3.0V, I _C =0			10	nA
Base Cut-Off Current	I _{BL}	V _{CE} =60V, V _{EB(OFF)} =3.0V			20	nA
ON CHARACTERISTICS						
DC Current Gain	h _{FE}	I _C =0.1mA, V _{CE} =10V	35			
		I _C =1.0mA, V _{CE} =10V	50			
		I _C =10mA, V _{CE} =10V	75			
		I _C =150mA, V _{CE} =10V (Note)	100		300	
		I _C =150mA, V _{CE} =1.0V (Note)	50			
		I _C =500mA, V _{CE} =10V (Note)	40			
Collector-Emitter Saturation Voltage (Note)	V _{CE(SAT)}	I _C =150mA, I _B =15mA			0.3	V
		I _C =500mA, I _B =50mA			1.0	
Base-Emitter Saturation Voltage (Note)	V _{BE(SAT)}	I _C =150mA, I _B =15mA	0.6		1.2	V
		I _C =500mA, I _B =50mA			2.0	
SMALL SIGNAL CHARACTERISTICS						
Transition Frequency	f _T	I _C =20mA, V _{CE} =20V, f=100MHz	300			MHz
Output Capacitance	C _{obo}	V _{CB} =10V, I _E =0, f=100kHz			8.0	pF
Input Capacitance	C _{ibo}	V _{EB} =0.5V, I _C =0, f=100kHz			25	pF
Collector Base Time Constant	τ _{b'Cc}	I _C =20mA, V _{CB} =20V, f=31.8MHz			150	pS
Noise Figure	NF	I _C =100μA, V _{CE} =10V, R _S =1.0kΩ, f=1.0kHz			4.0	dB
Real Part of Common-Emitter High Frequency Input Impedance	Re(h _{je})	I _C =20mA, V _{CB} =20V, f=300MHz			60	Ω
SWITCHING CHARACTERISTICS						
Delay time	t _D	V _{CC} =30V, V _{BE(OFF)} =0.5V			10	ns
Rise time	t _R	I _C =150mA, I _{B1} =15mA			25	ns
Storage time	t _S	V _{CC} =30V, I _C =150mA			225	ns
Fall time	t _F	I _{B1} = I _{B2} =15mA			60	ns

Note: Pulse test: Pulse Width ≤ 300μs, Duty Cycle ≤ 2.0%

PN2222A

NPN SILICON TRANSISTOR

■ TEST CIRCUIT

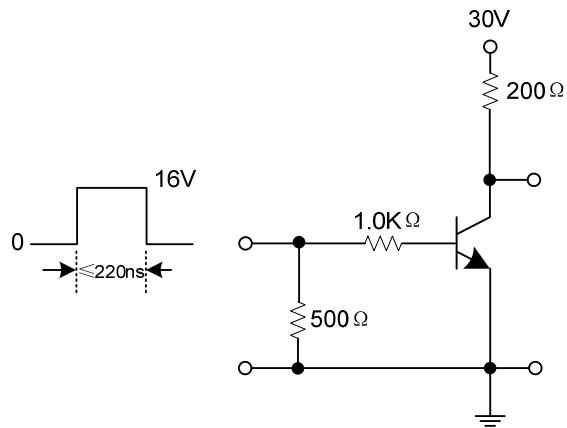

Saturated Turn-On Switching Time

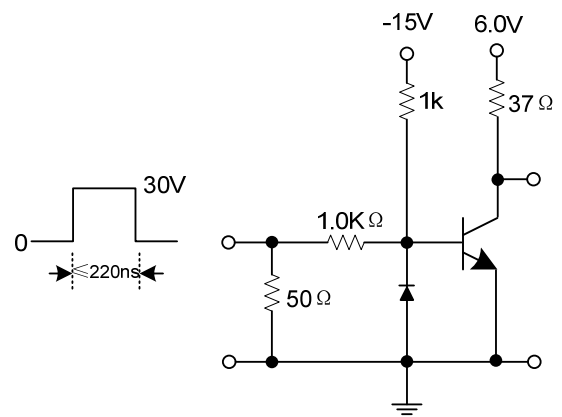

Saturated Turn-Off Switching Time

■ TYPICAL CHARACTERISTICS

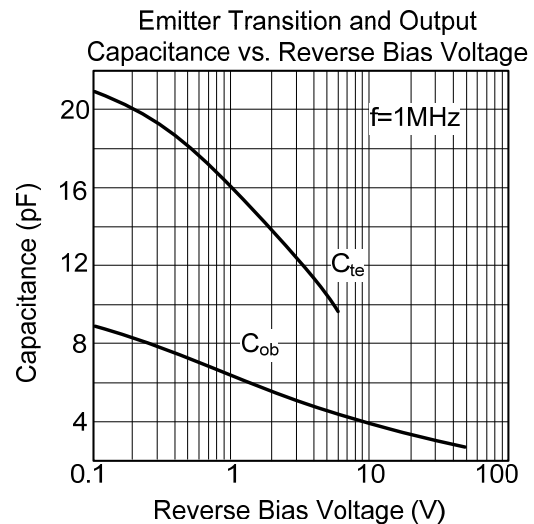
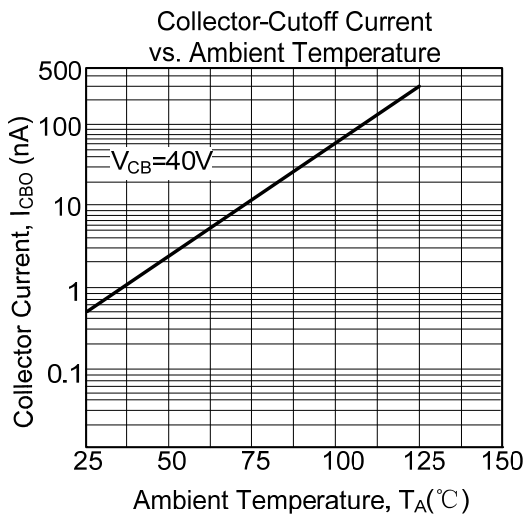
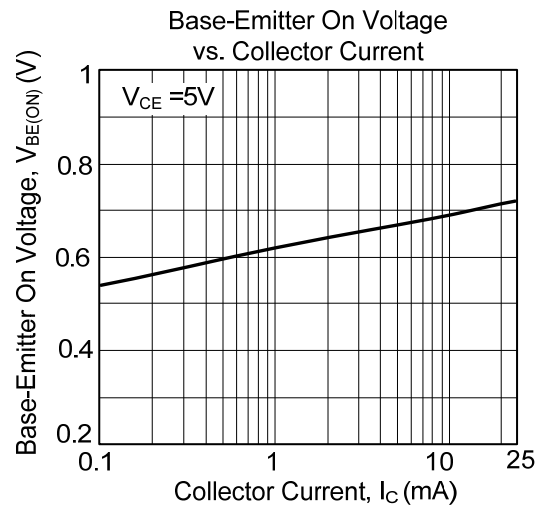
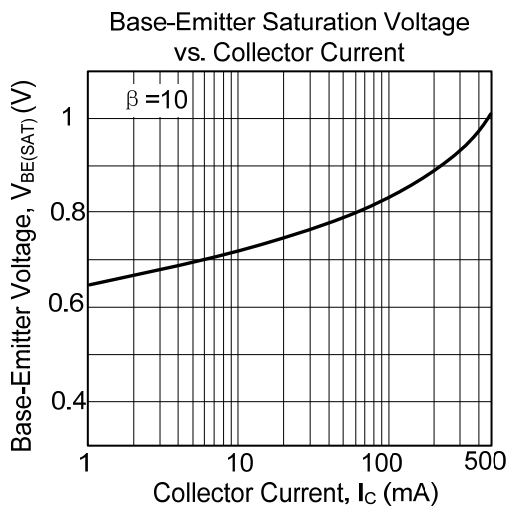
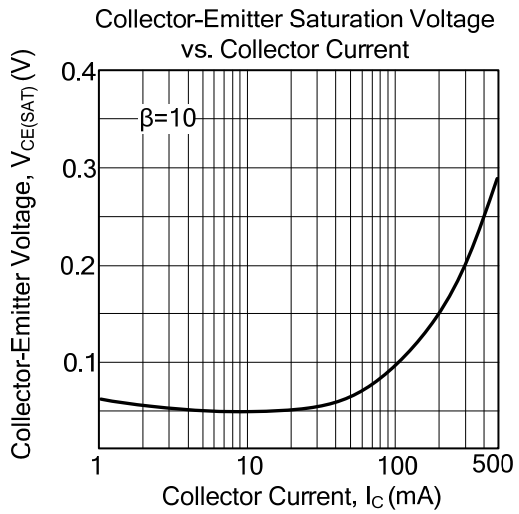
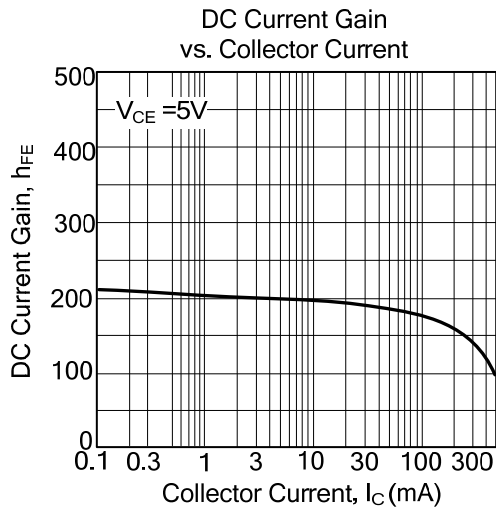

■ TYPICAL CHARACTERISTICS(Cont.)

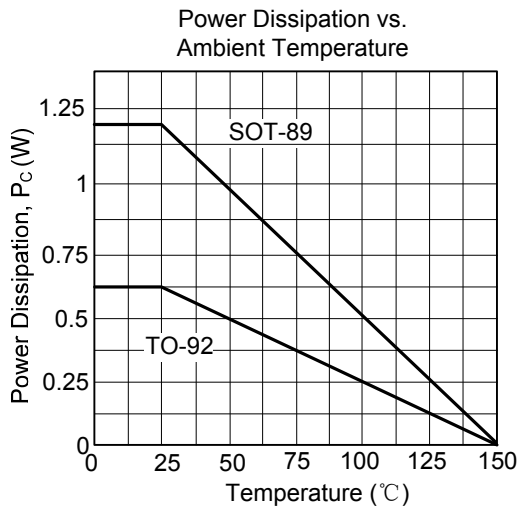
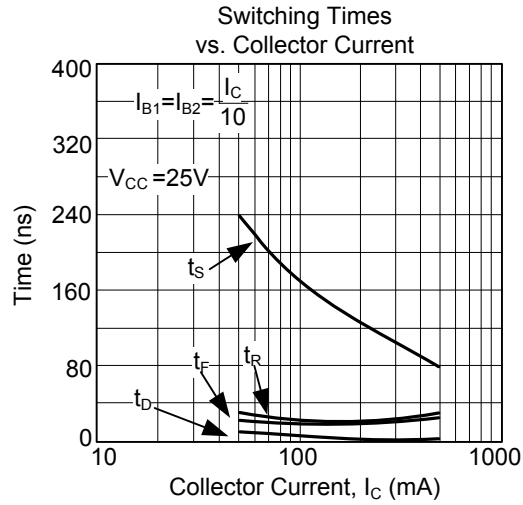
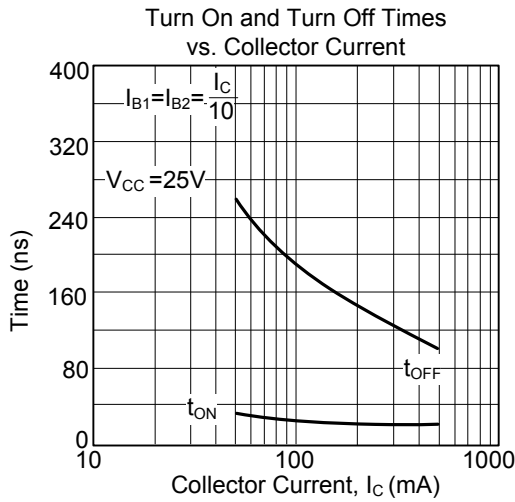

UTC assumes no responsibility for equipment failures that result from using products at values that exceed, even momentarily, rated values (such as maximum ratings, operating condition ranges, or other parameters) listed in products specifications of any and all UTC products described or contained herein. UTC products are not designed for use in life support appliances, devices or systems where malfunction of these products can be reasonably expected to result in personal injury. Reproduction in whole or in part is prohibited without the prior written consent of the copyright owner. The information presented in this document does not form part of any quotation or contract, is believed to be accurate and reliable and may be changed without notice.