

Internal BJT Low Standby-Power QR Primary-side Converter

General description

The PN8571 consists of a Low Standby-Power Quasi-Resonant(QR) Primary-Side controller and BJT, specifically designed for a high performance AC/DC charger or adapter with minimal external components.

PN8571 operates in primary-side sensing and regulation, so opto-coupler and TL431 could be eliminated. In CV mode, multi-mode and quasi resonant technique is utilized to achieve high efficiency, avoid audible noise and make the system meeting Energy star level VI. Good load regulation is achieved by the built-in cable drop compensation. In CC mode, the current and output power setting can be adjusted externally by the sense resistor at CS pin.

PN8571 offers complete protections including Cycle-by-Cycle current limiting protection (OCP), over voltage protection (OVP), open loop protection (OLP), over temperature protection (OTP) and CS open or short protection (CS O/SP) etc.

Application

- Switch AC/DC Adapter
- Battery Charger
- Set-top box power supply

Output Features

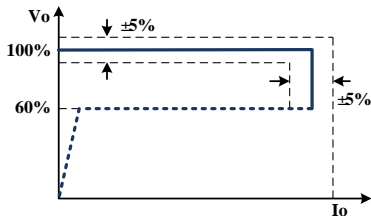

Typical Circuit

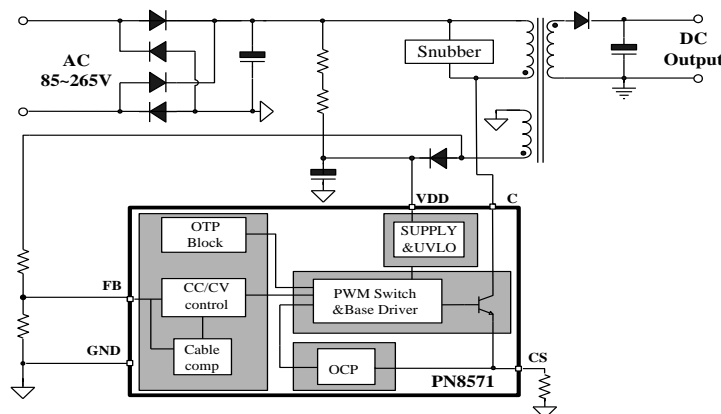

Features

- Internal BJT switch
- Multi-mode and Quasi-Resonant technique
- $\pm 5\%$ CC Regulation at Universal AC input
- Primary-side Sensing and Regulation without TL431 and Opto-coupler
- Programmable Cable Drop Compensation
- No-need Control Loop Compensation Capacitor
- Excellent Protection include:
 - ◇ Over Temperature Protection (OTP)
 - ◇ VDD Under/Over Voltage Protection(UVLO&OVP)
 - ◇ Cycle-by-Cycle Current Limiting (OCP)
 - ◇ CS Short/Open Protection (CS O/SP)
 - ◇ Open Loop Protection(OLP)

Package/Order Information

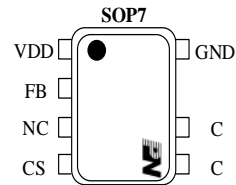

Order code	Package	Typical Power
		85~265V _{AC}
PN8571LSSC-R1	SOP7	5W
PN8571MSSC-R1	SOP7	7.5W
PN8571HSSC-R1	SOP7	10W

Pin Definitions

Pin Name	Pin Number	Pin Function Description
VDD	1	Power supply
FB	2	The voltage feedback from auxiliary winding. Connected to resistor divider from auxiliary winding reflecting output voltage.
NC	3	No connection
CS	4	Current Sense Input
C	5,6	HV BJT collector pin
GND	7	Ground

Typical Power

Part number	Package	Adapter ⁽¹⁾
		85~265V _{AC}
PN8571L	SOP7	5W
PN8571M	SOP7	7.5W
PN8571H	SOP7	10W

Note:

1. Maximum output power is tested in an adapter at 40 °C ambient temperature, with enough cooling conditions.

Block Diagram

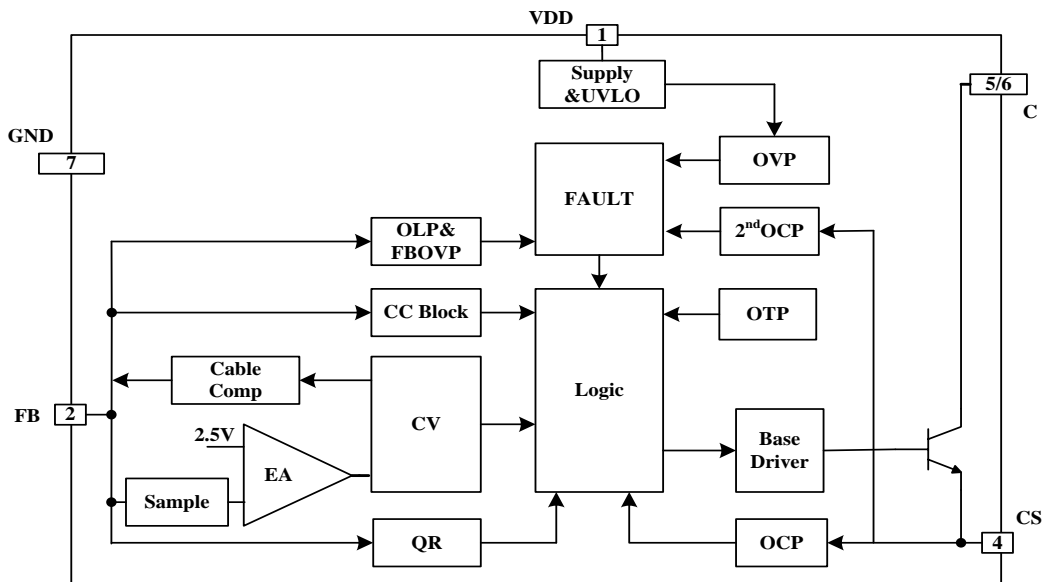

Absolute Maximum Ratings

Supply voltage Pin VDD.....	-0.3~40V
Pin CS	-0.3~5.5V
Pin FB(I _{FB} ≤10mA)	-1~5.5V
CB voltage-PN8571L/M	800V
CB voltage-PN8571H.....	700V

Operating Junction Temperature.....	-40~150 °C
Storage Temperature Range.....	-55~150 °C
Lead Temperature (Soldering, 10Secs).....	260 °C
Package Thermal Resistance θ _{JC} (SOP7)	40 °C /W
HBM ESD Protection ⁽¹⁾	±3kV

Note:

1. Test standard: ANSI/ESDA/JEDEC JS-001-2017.

Electrical Characteristics

(T_A= 25 °C, VDD=21V, unless otherwise specified)

PARAMETER	SYMBOL	CONDITIONS	MIN.	TYP.	MAX.	UNIT
Power Section						
Collector-base breakdown voltage	V _{CBO}	I _C =10mA , PN8571L/M	800			V
		I _C =10mA , PN8571H	700			V
Collector-emitter breakdown voltage	V _{CEO}	I _C =10mA, I _B =0		480		V
Collector Peak Current	I _C	PN8571L			450	mA
		PN8571M			500	mA
		PN8571H			750	mA
Supply Voltage Section						
Operating voltage range	VDD		9.0		30	V
VDD start up threshold	VDD _{on}		14.5	16.5	18.5	V
VDD under voltage shutdown threshold	VDD _{off}		7	8	9	V
VDD over voltage protect	VDD _{ovp}		30	33	36	V
Supply Current Section						
VDD charge current	I _{DD_STARTUP}	VDD=VDD _{on} - 1V		3	5	uA
Operating current, switching	I _{DD}	VDD = VDD _{on} +1V	0.1	0.5	0.8	mA
Operating current after fault	I _{DD_FAULT}	VDD= 15V after fault		0.5		mA
Current Sense Section						
Current sense threshold	V _{TH_OC}		485	500	515	mV
Maximum Current sense threshold	V _{TH_OC_MAX}			560		mV
Minimum CS threshold	V _{cs_min}			170		mV
Leading Edge Blanking time	T _{LEB}			300		ns
Maximum Ton	T _{onmax}		32	40	50	us
OCP propagation delay	T _{D_OC}			100		ns
FB Section						
Reference voltage for feedback threshold	V _{REF_CV}		2.475	2.5	2.54	V
Output over voltage protection threshold	V _{FBOVP}		2.85	3	3.15	V

PARAMETER	SYMBOL	CONDITIONS	MIN.	TYP.	MAX.	UNIT
Output under voltage threshold	V_{UVP}			1.55		V
Maximum cable compensation current	I_{cable}	$V_{FB}=0V$	33	36	39	μA
Minimum Toff	T_{offmin}			5		μs
Maximum Toff	T_{offmax}			2.2		ms
Output under voltage protection Blanking time	T_{UVP}	$F_S=50kHz$	40		64	ms
Thermal Section						
Thermal shutdown temperature threshold	T_{SD}		135	150		$^{\circ}C$
Thermal shutdown hysteresis	T_{HYST}			30		$^{\circ}C$

Typical Characteristics Plots

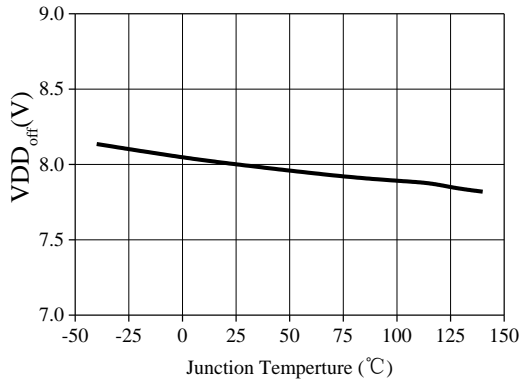

(a) VDD_{off} VS T_j

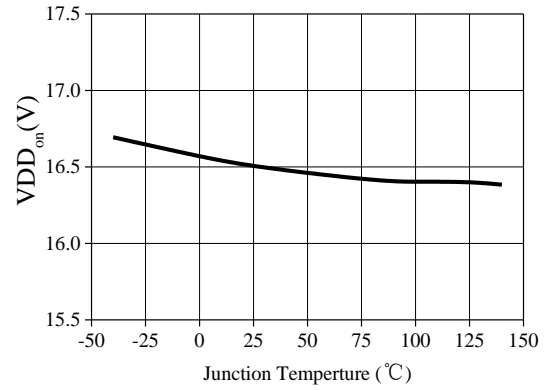

(b) VDD_{on} VS T_j

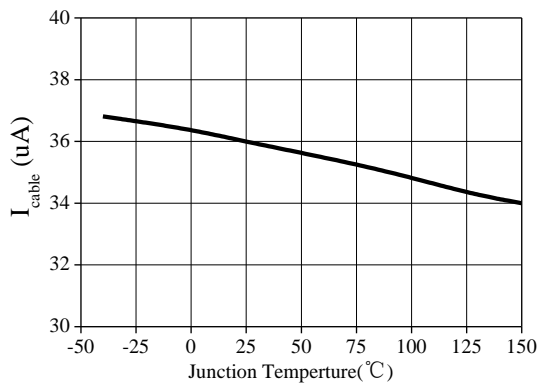

(c) I_{cable} VS T_j

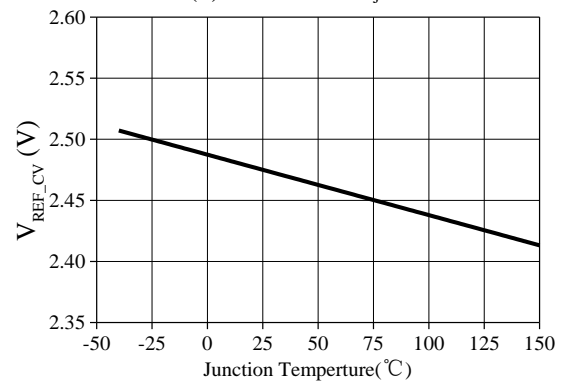

(d) V_{REF_CV} VS T_j

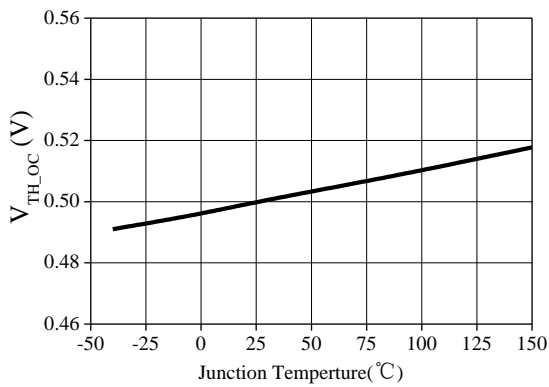

(e) V_{TH_OC} VS T_j

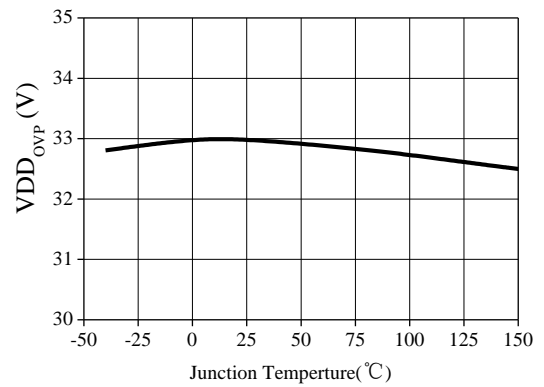

(f) VDD_{OVP} VS T_j

Functional Description

The PN8571 is a high performance CC/CV primary-side controller. PN8571 operates in primary-side sensing and regulation, so opto-coupler and TL431 could be eliminated. Proprietary built-in CV and CC control can achieve high precision CC/CV control meeting most charger and adapter application requirements. Startup current of PN8571 is designed to be very low so a large value startup resistor can be used to minimize the power loss in application.

1. Start up Control

At start up, external startup resistor charges the VDD capacitor via VDD pin. When VDD reaches VDD_{on}, the device starts switching. The device keeps in normal operation provided as long as VDD keeps above VDD_{off}. After startup, the bias is supplied from the auxiliary transformer winding.

2. CC Operation Mode

In CC operation mode, the PN8571 captures the auxiliary flyback signal at FB pin through a resistor dividing-network. The pulse width of the auxiliary flyback signal determines the PN8571 oscillator frequency. The higher the output voltage is, the shorter the pulse width is, and the higher the chip oscillator frequency is, thus the constant output current can be achieved.

The current waveform in DCM mode is shown in Fig.1. During BJT turn-on time, the current in the primary winding (I_{pri}) ramps up. When BJT turns off, the energy stored in the primary winding is transferred to the secondary side, so the peak current in the secondary winding is

$$I_{sec_pk} = I_{pri_pk} \times N_{ps} \quad (1)$$

The output average current is

$$I_O = \frac{I_{sec_pk}}{2} \times \frac{T_{demag}}{T_p} = \frac{1}{2} N_{PS} \frac{V_{CS}}{R_{sense}} \frac{T_{demag}}{T_p} \quad (2)$$

Where R_{sense} means system resistor at CS pin, N_{PS} means primary winding and secondary winding turn ratio.

In CC mode, PN8571 fixes $\frac{T_{demag}}{T_p}$ to be 0.5, and V_{CS} to be

V_{TH_OC} (typically 0.5V, actually about 0.58V considering the affection of system and delay time). Meanwhile, assuming the current coupling ratio is K_c, the output current will be constant as:

$$I_O = \frac{1}{4} N_{PS} \frac{0.58}{R_{sense}} \times K_c \quad (3)$$

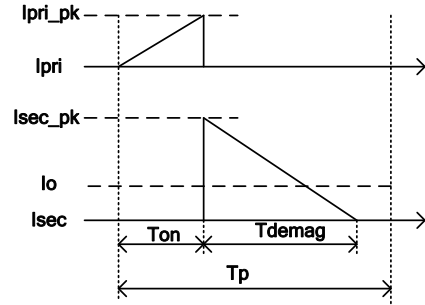

Fig.1 The current waveform in DCM mode

3. CV Operation Mode

In CV mode, PN8571 uses a pulse to sample V_{FB} and holds hold until the next sampling. The sampled voltage is compared with V_{REF_CV} and the error is amplified. The error amplified output reflects the load condition and controls the switching off time to regulate the output voltage, thus constant output voltage can be achieved.

The relationship between the output voltage and V_{REF_CV} is

$$V_O = (V_{REF_CV} \times \frac{R1 + R2}{R2}) \times \frac{N_S}{N_{AUX}} \quad (4)$$

N_S means Secondary winding turns, N_{AUX} means Auxiliary winding turns.

The PN8571 operates in PFM_QR mode during full load mode, since the peak current (I_{peak}) of BJT is constant, the chip frequency decreases while the output current decreases. When the switching frequency approaches to 25kHz, the PN8571 enters PWM_QR mode, the chip frequency decreases slowly while the output current decreases, the I_{peak} decreases while the output current decreases. Therefore the PN8571 can avoid audible noise, while achieving high efficiency at 25% load conditions. When V_{cs} decreases to 170mV, the PN8571 enters Standby mode. In this mode, I_{peak} keeps around constant, the chip oscillator frequency decreases while the output current decreases. Fig.2 illustrates the relations of the switching frequency, I_{peak} and Loading for PN8571.

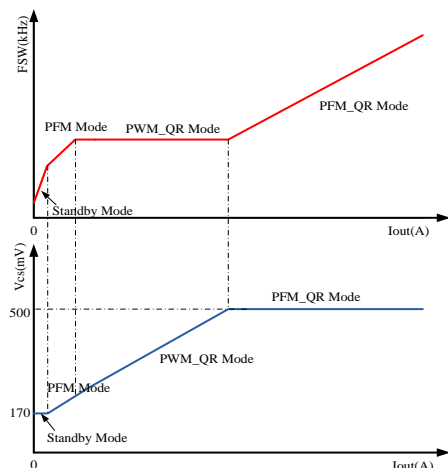

Fig.2 The Switching Frequency, V_{CS} VS. LOAD

4. Current Sensing and Leading Edge Blanking

Cycle-by-Cycle current limiting is offered in PN8571. The switch current is detected by a sense resistor at CS pin. The CC set-point and maximum output power can be externally adjusted by external current sense resistor at CS pin. An internal leading edge blanking circuit chops off the sensed voltage spike at initial power BJT on-state so that the external RC filtering on sense input is no longer needed.

5. Programmable Cable Drop Compensation

In PN8571, an offset voltage is generated at FB pin by an internal current flowing into the divider resistor, as shown in Fig.3. The Cable Drop Compensation block compensates the voltage drop across the cable. As the load current decreases from full load to no load, the voltage drop across the cable decreases. It can be programmed by adjusting the external resistor R2 or R1 at FB pin. The maximum compensation is

$$\frac{V_{cable}}{V_O} = \frac{I_{cable} \times (R2 // R1)}{2.5V} \quad (5)$$

Because of the influence of the chip's sampling position and parameters of the system, the actual maximum compensation may be less than theoretical value.

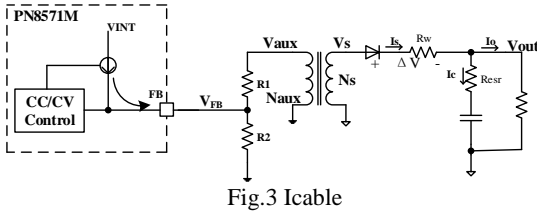

Fig.3 I cable

6. Reference Negative Temperature Compensation

As shown in Fig.3, the voltage of FB pin is

$$V_{FB} = K_R (V_O + \Delta V), \quad K_R = \frac{R2 \times N_{AUX}}{(R1 + R2) \times N_S} \quad (6)$$

Where ΔV has a negative temperature coefficient, K_R is a constant.

In PN8571, the voltage reference uses the negative temperature compensation technology. At room temperature, the voltage reference is 2.5V. The voltage reference (V_{REF_CV}) decreases while the temperature of chip increases. The reference negative temperature compensation block compensates the ΔV represented rectifier diode VF variation, thus the output voltage keeps constant at full range of temperature. The reference negative temperature compensation improves output precision.

7. Quasi-Resonant Switching

The PN8571 incorporates a unique proprietary quasi-resonant switching scheme that achieves valley-mode turn on for every switching cycle in CV mode. This unique feature greatly reduces the switching loss. The actual switching frequency can vary slightly cycle by cycle, providing the additional benefit of reducing EMI.

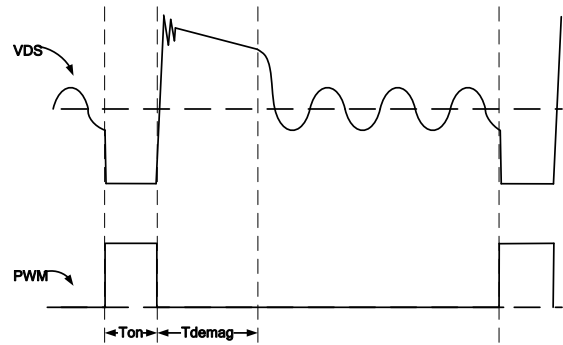
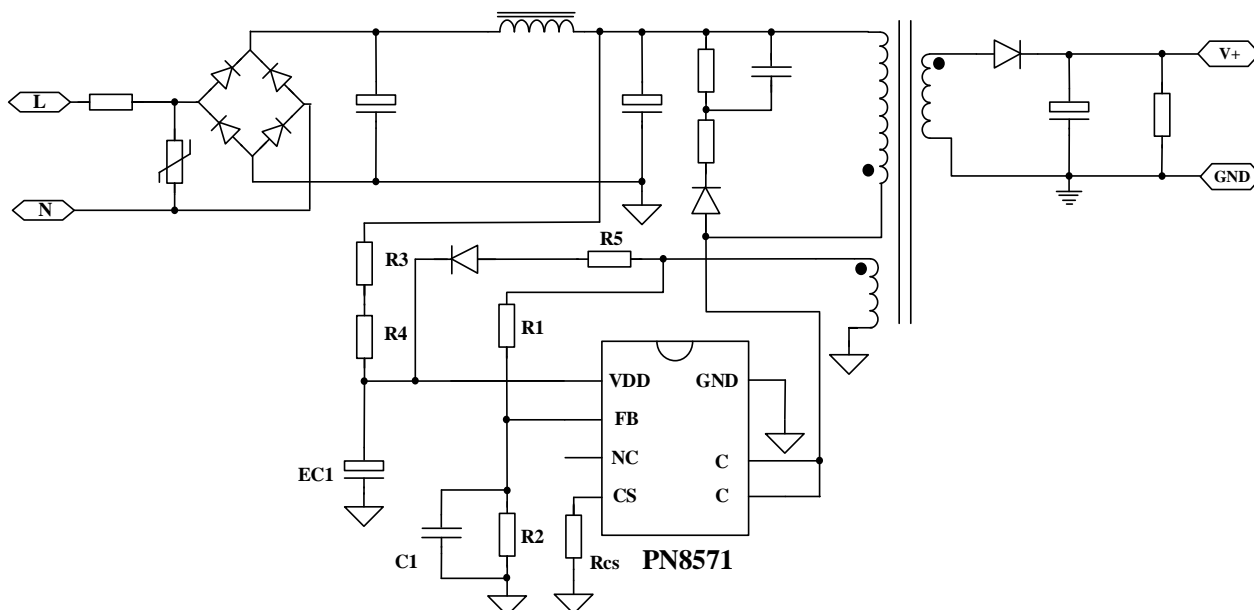

Fig.4 QR Mode

8. Protection Control

The PN8571 has several self-protection functions, such as Cycle-by-Cycle current limiting (OCP), Over-Voltage Protection, Over-Temperature Protection, Feedback Loop open Protection, Output short circuit Protection, CS resistor open/short circuit Protection and Under Voltage Lockout on VDD. All protections are self-recovered.

Typical Application



Component Parameter and Layout Considerations:

1. VDD capacitor EC1 should be placed at the nearest place between the VDD pin and the GND pin.
2. It is suggested that the power supply diode and the R5 should be connected in series in order to improve the safety capability. The recommend value is 4.7ohm.
3. It is suggested that the FB pin and the C1 should be connected in parallel in order to improve the anti-interference of the sampling network. The recommend value is 47pF.
4. Choose CS resistance reasonably to avoid I_C exceeding 0.45A (PN8571L), 0.5A (PN8571M), 0.75A (PN8571H).

Package Information

Package Information SOP7

Symbol	Size	Min. (mm)	Max. (mm)	Symbol	Size	Min. (mm)	Max. (mm)
A		1.45	1.75	E		5.8	6.2
A1		0.05	0.25	E1		3.85	4.05
A2		1.35	1.55	L		0.4	1.27
b		0.3	0.5	θ		0°	8°
D		4.7	5.1	e		1.270(BSC)	

Order codes	Top mark	Package
PN8571LSSC-R1	PN8571L YWWXXXXX	SOP7
PN8571MSSC-R1	PN8571M YWWXXXXX	SOP7
PN8571HSSC-R1	PN8571H YWWXXXXX	SOP7

Note: Y: Year Code; WW: Week Code; XXXX: Internal Code

Notes:

1. This drawing is subjected to change without notice.
2. Body dimensions do not include mold flash or protrusion.

Tape and Reel Information

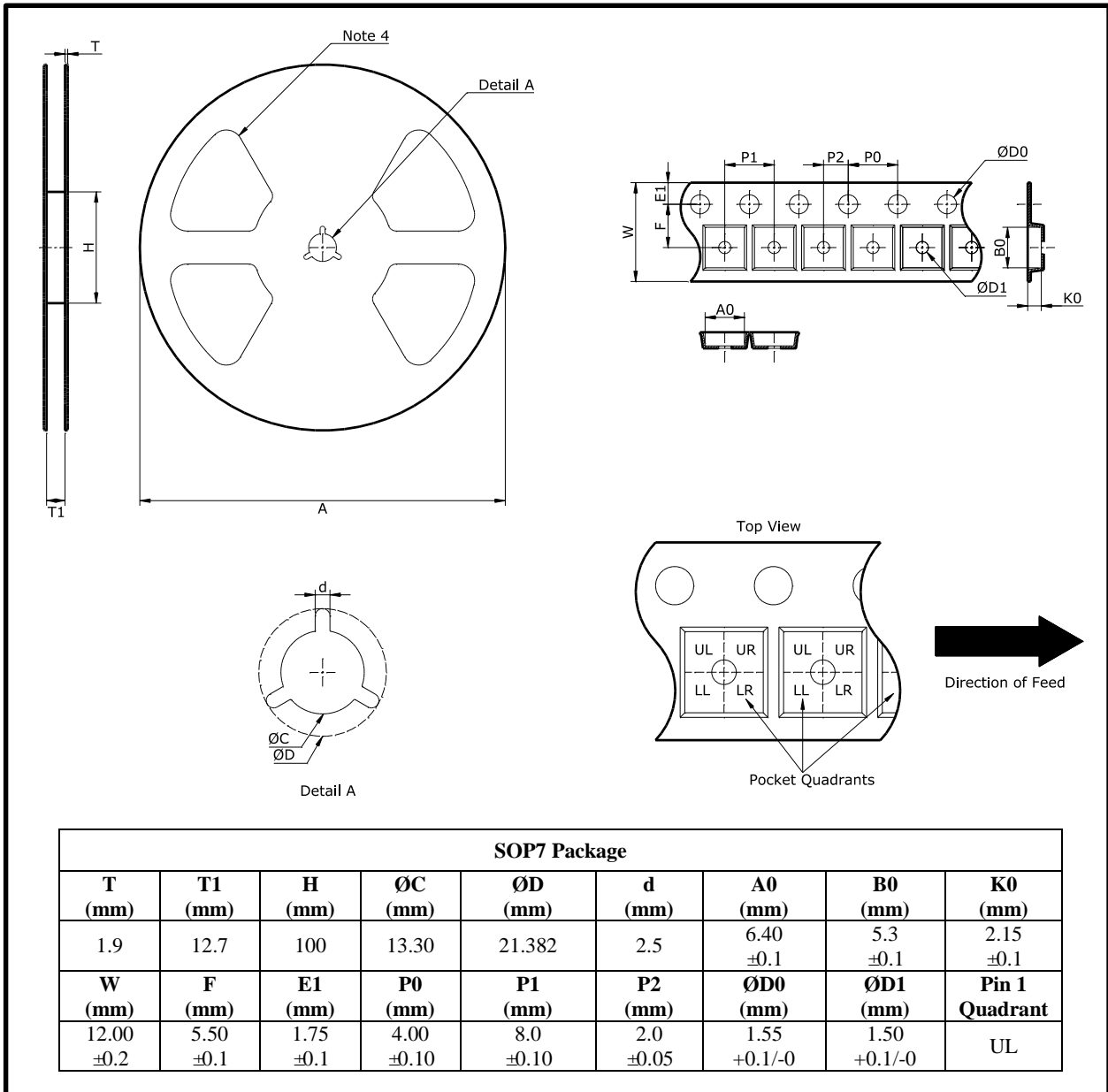

Notes:

1. This drawing is subjected to change without notice.
2. All dimensions are nominal and in mm.
3. This drawing is not in scale and for reference only. Customer can contact Chipown sales representative for further details.
4. The number of flange openings depends on the reel size and assembly site. This drawing shows an example only.

Important Notice

Wuxi Chipown Microelectronics Co. Ltd. reserves the right to make changes without further notice to any products or specifications herein. Wuxi Chipown Microelectronics Co. Ltd. does not assume any responsibility for use of any its products for any particular purpose, nor does Wuxi Chipown Microelectronics Co. Ltd assume any liability arising out of the application or use of any its products or circuits. Wuxi Chipown Microelectronics Co. Ltd does not convey any license under its patent rights or other rights nor the rights of others.