

# SHARP

OPTO-ELECTRONIC DEVICES DIVISION  
ELECTRONIC COMPONENTS GROUP  
SHARP CORPORATION

## SPECIFICATION

DEVICE SPECIFICATION FOR

VOLTAGE REGULATOR

MODEL No.

PQ\*\*RD1BJ00H

Applied model name

	PQ05RD1BJ00H
	PQ09RD1BJ00H
	PQ12RD1BJ00H

Specified for \_\_\_\_\_

Enclosed please find copies of the Specifications which consists of 13 pages including cover.  
After confirmation of the contents, please be sure to send back  copies of the Specifications  
with approving signature on each.

CUSTOMER'S APPROVAL

DATE \_\_\_\_\_

BY \_\_\_\_\_

PRESENTED

DATE \_\_\_\_\_

BY           H. Imanaka          

H.Imanaka,  
Department General Manager of  
Engineering Dept.,II  
Opto-Electronic Devices Div.  
ELECOM Group  
SHARP CORPORATION

Product name : VOLTAGE REGULATOR

Model No. : PQ\*\*RD1BJ00H

Applied Model No. : PQ05RD1BJ00H, PQ09RD1BJ00H, PQ12RD1BJ00H

1. These specification sheets include materials protected under copyright of Sharp Corporation ("Sharp"). Please do not reproduce or cause anyone to reproduce them without Sharp's consent.
2. When using this product, please observe the absolute maximum ratings and the instructions for use outlined in these specification sheets, as well as the precautions mentioned below. Sharp assumes no responsibility for any damage resulting from use of the product which does not comply with the absolute maximum ratings and the instructions included in these specification sheets, and the precautions mentioned below.

(Precautions)

- (1) This product is designed for use in the following application areas ;

( • OA equipment   • Audio visual equipment   • Home appliances  
• Telecommunication equipment (Terminal)   • Measuring equipment  
• Tooling machines   • Computers )

If the use of the product in the above application areas is for equipment listed in paragraphs (2) or (3), please be sure to observe the precautions given in those respective paragraphs.

- (2) Appropriate measures, such as fail-safe design and redundant design considering the safety design of the overall system and equipment, should be taken to ensure reliability and safety when this product is used for equipment which demands high reliability and safety in function and precision, such as ;

( • Transportation control and safety equipment (aircraft, train, automobile etc.)  
• Traffic signals   • Gas leakage sensor breakers   • Rescue and security equipment  
• Other safety equipment )

- (3) Please do not use this product for equipment which require extremely high reliability and safety in function and precision, such as ;

( • Space equipment   • Telecommunication equipment (for trunk lines)  
• Nuclear power control equipment   • Medical equipment )

- (4) Please contact and consult with a Sharp sales representative if there are any questions regarding interpretation of the above three paragraphs.

3. Please contact and consult with a Sharp sales representative for any questions about this product.

1. Application

This specification applies to the outline and characteristics of low power dissipation regulator (linear type), Model No. PQ\*\*RD1BJ00H.

Usage

PQ\*\*RD1BJ00H are the devices for stabilization of positive DC output voltage with built-in ON/OFF function, the over current protection function, the overheat protection function and the ASO protection function.

These devices are possible to be used in power supply circuit up to current capacity 1A.

Block diagram

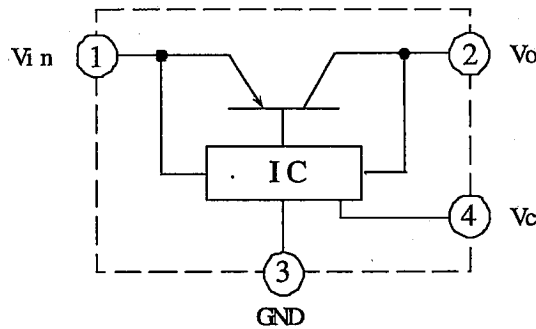

2. Outline : Refer to the attached sheet, Page 3.

3. Ratings and characteristics : Refer to the attached sheet, page 4 to 7.

3.1 Absolute maximum ratings

3.2 Electrical characteristics

3.3 Electrical characteristics measuring circuit

4. Reliability : Refer to the attached sheet, Page 8.

5. Outgoing inspection : Refer to the attached sheet, Page 9.

6. Supplement : Refer to the attached sheet, Page 9, 10.

6.1 Example of application

6.2 Over current protection characteristics (Typical value)

6.3 ODS materials

This product shall not contain the following materials.

Also, the following materials shall not be used in the production process for this product.

Materials for ODS : CFC<sub>s</sub>, Halon, Carbon tetrachloride,

1.1.1-Trichloroethane (Methylchloroform)

6.4 Brominated flame retardants

Specific brominated flame retardants such as the PBBO<sub>s</sub> and PBB<sub>s</sub> are not used in this device at all.

6.5 This product is not designed as electromagnetic and ionized-particle radiation resistant.

7. Notes : Refer to the attached sheet, Page 11, 12.

7.1 External connection

7.2 Mounting

7.3 Thermal protection design

7.4 Static electricity

7.5 For cleaning

7.6 Storage environment

**REFERENCE**

2. Outline

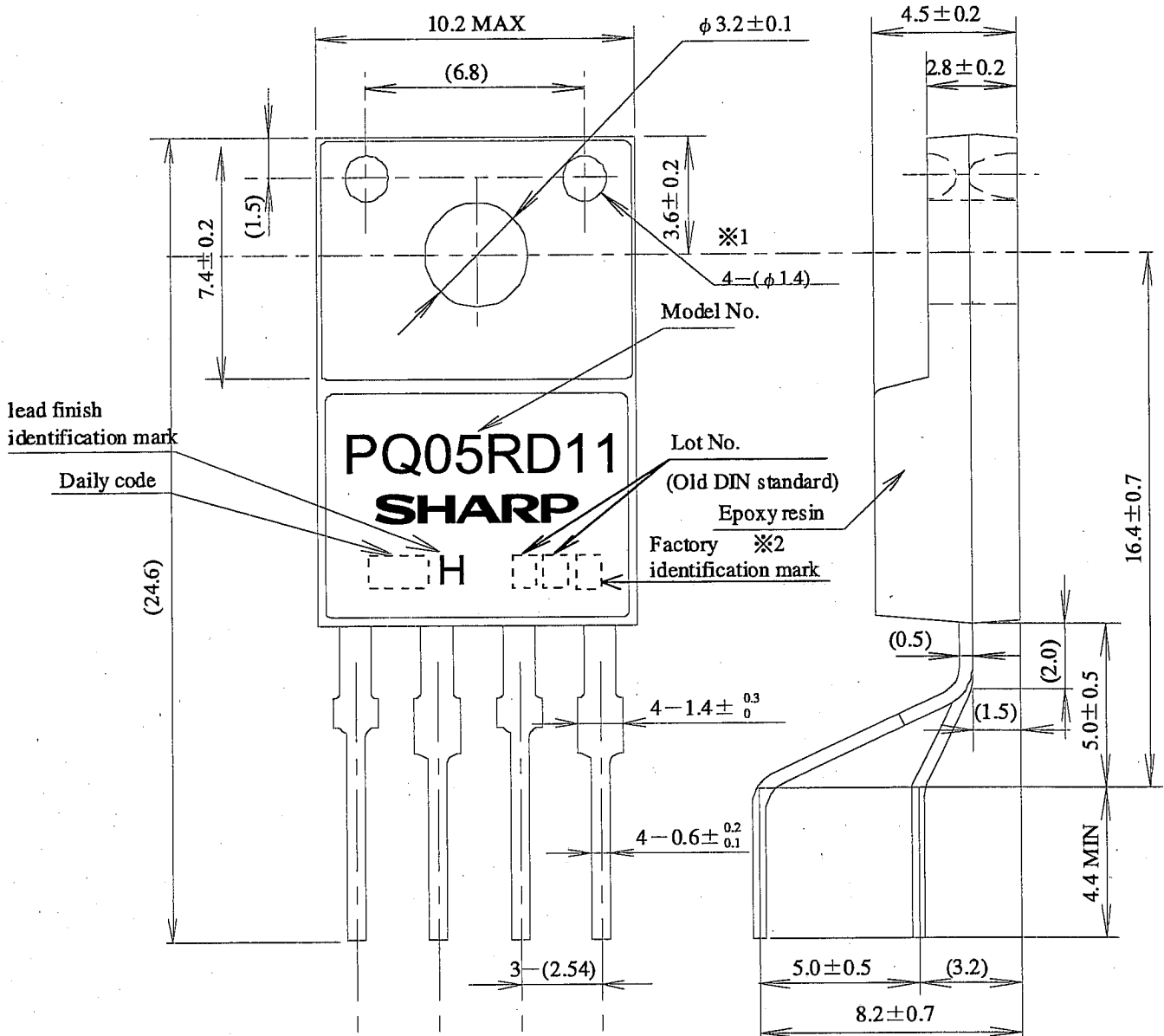

lead finish identification mark  
Daily code

**PQ05RD11**  
**SHARP**

Model No.

Lot No.  
(Old DIN standard)

Epoxy resin  
Factory identification mark

- ( ) : TYP.
- Unit : mm
- Scale : 5/1

- ① : DC input (Vin)
- ② : DC output (Vo)
- ③ : GND
- ④ : ON/OFF control (Vc)

Date	Daily code indication
1	1
2	2
3	3
.	.
.	.
30	30
31	31

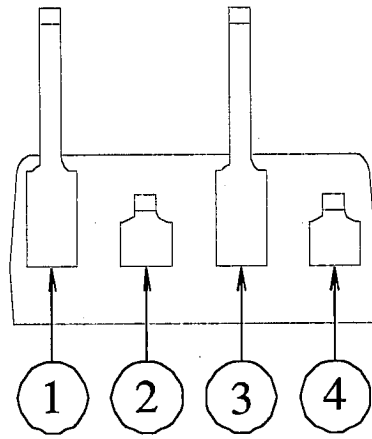

Applied model No.	Marked model No.
PQ05RD1BJ00H	PQ05RD11
PQ09RD1BJ00H	PQ09RD11
PQ12RD1BJ00H	PQ12RD11

- Lead finish : Lead free solder plating (Composition:Sn2Cu)
- Lead material : Cu
- Product mass : 1.5 ± 0.2g

※1 The holes are both the surface and the under surface.  
 ※2 ▲: P.T.SHARP SEMICONDUCTOR INDONESIA  
 Without : Fujimoto Electric. Co., Ltd.

**REFERENCE**

3. Ratings and characteristics

3.1 Absolute maximum ratings

Ta=25°C

Parameter	Symbol	Rating	Unit	Conditions
Input voltage (*1)	Vin	20	V	
ON/OFF control terminal voltage (*1)	Vc	20	V	
Output current	Io	1.0	A	
Powerdissipation (*2)	Pd1	1.4	W	Refer to Fig. 1
	Pd2	15	W	
Junction temperature (*3)	Tj	150	°C	
Operating temperature	Topr	-20 to +80	°C	
Storage temperature	Tstg	-40 to +150	°C	
Soldering temperature	Tsol	260	°C	For 10 s

(\*1) All are open except GND and applicable terminals.

(\*2) Pd1 : No heat sink, Pd2 : With infinite heat sink

(\*3) There is case that over heat protection function operates at the temperature Tj=125 to 150°C, this item cannot be used in this temperature range.

Fig. 1 Pd - Ta rating

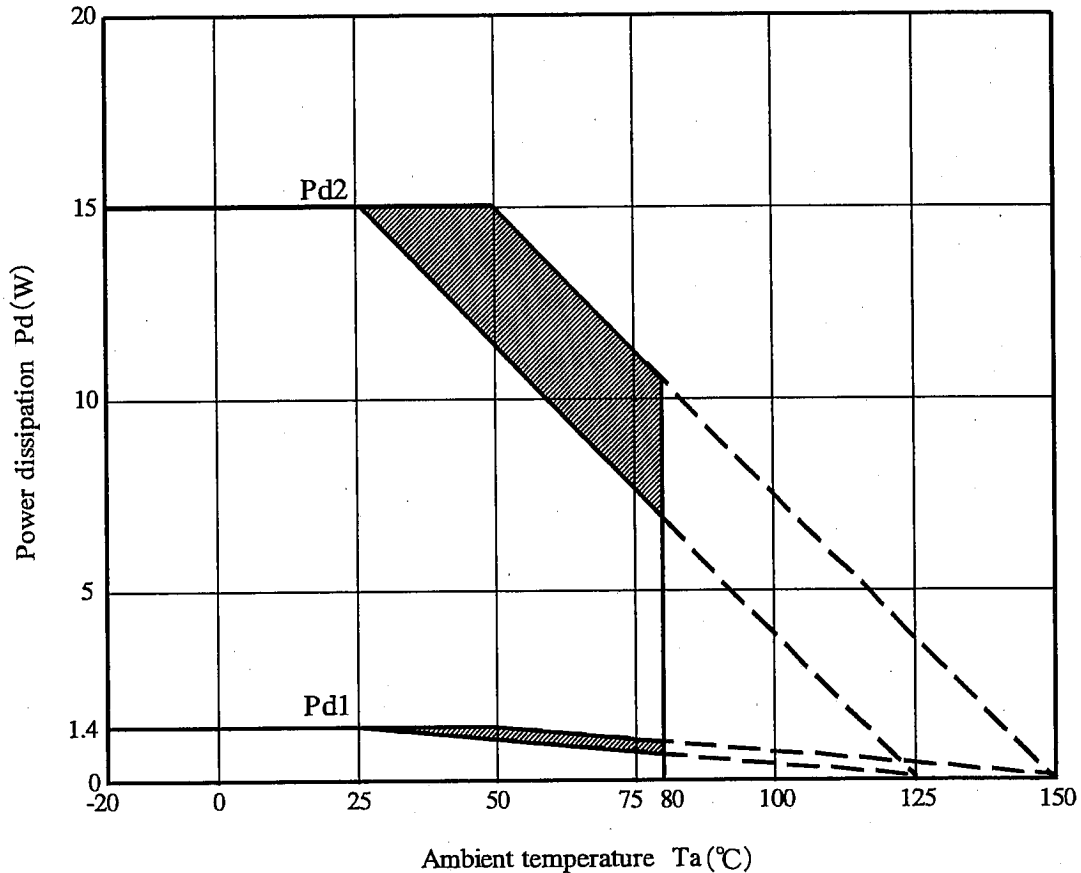

Pd 1 : No heat sink

Pd 2 : With infinite heat sink

(Note) There is case that over heat protection function operates at oblique line portion.

# REFERENCE

### 3.2 Electrical characteristics

#### (1) PQ05RD1BJ00H

Unless otherwise specified condition shall be  $V_{in}=7V$ ,  $I_o=0.5A$

$T_a=25^{\circ}C$

Parameter	Symbol	MIN.	TYP.	MAX.	Unit	Conditions
Output voltage	$V_o$	4.85	5	5.15	V	
Load regulation	RegL	-	0.1	2.0	%	$I_o=5mA$ to 1A
Line regulation	RegI	-	0.5	2.5	%	$V_{in}=6$ to 12V $I_o=5mA$
Temperature coefficient of output voltage	$TcV_o$	-	$\pm 0.02$	-	%/°C	$T_j=0$ to 125°C $I_o=5mA$
Ripple rejection	RR	45	55	-	dB	Refer to Fig.3
Dropout voltage	$V_{i-o}$	-	-	0.5	V	(*4) $I_o=0.5A$
On-state voltage for control (*5)	$V_c$ (on)	2.0	-	-	V	
On-state current for control	$I_c$ (on)	-	-	20	$\mu A$	$V_c=2.7V$
Off-state voltage for control	$V_c$ (off)	-	-	0.8	V	
Off-state current for control	$I_c$ (off)	-	-	-0.4	mA	$V_c=0.4V$
Quiescent current	$I_q$	-	-	10	mA	$I_o=0A$

(\*4) Input voltage shall be the value when output voltage is 95% in comparison with the initial value.

(\*5) In case of opening control terminal (4th pin), output voltage turns ON.

#### (2) PQ09RD1BJ00H

Unless otherwise specified condition shall be  $V_{in}=11V$ ,  $I_o=0.5A$

$T_a=25^{\circ}C$

Parameter	Symbol	MIN.	TYP.	MAX.	Unit	Conditions
Output voltage	$V_o$	8.73	9.0	9.27	V	
Load regulation	RegL	-	0.1	2.0	%	$I_o=5mA$ to 1A
Line regulation	RegI	-	0.5	2.5	%	$V_{in}=10$ to 16V $I_o=5mA$
Temperature coefficient of output voltage	$TcV_o$	-	$\pm 0.02$	-	%/°C	$T_j=0$ to 125°C $I_o=5mA$
Ripple rejection	RR	45	55	-	dB	Refer to Fig.3
Dropout voltage	$V_{i-o}$	-	-	0.5	V	(*4) $I_o=0.5A$
On-state voltage for control (*5)	$V_c$ (on)	2.0	-	-	V	
On-state current for control	$I_c$ (on)	-	-	20	$\mu A$	$V_c=2.7V$
Off-state voltage for control	$V_c$ (off)	-	-	0.8	V	
Off-state current for control	$I_c$ (off)	-	-	-0.4	mA	$V_c=0.4V$
Quiescent current	$I_q$	-	-	10	mA	$I_o=0A$

(\*4) Input voltage shall be the value when output voltage is 95% in comparison with the initial value.

(\*5) In case of opening control terminal (4th pin), output voltage turns ON.

# REFERENCE

## (3) PQ12RD1BJ00H

Unless otherwise specified condition shall be  $V_{in}=14V$ ,  $I_o=0.5A$

$T_a=25^{\circ}C$

Parameter	Symbol	MIN.	TYP.	MAX.	Unit	Conditions
Output voltage	$V_o$	11.64	12.0	12.36	V	
Load regulation	RegL	-	0.1	2.0	%	$I_o=5mA$ to 1A
Line regulation	Regl	-	0.5	2.5	%	$V_{in}=13$ to 19V $I_o=5mA$
Temperature coefficient of output voltage	$TcV_o$	-	$\pm 0.02$	-	%/°C	$T_j=0$ to 125°C $I_o=5mA$
Ripple rejection	RR	45	55	-	dB	Refer to Fig.3
Dropout voltage	$V_{i-o}$	-	-	0.5	V	(*4) $I_o=0.5A$
On-state voltage for control (*5)	$V_c$ (on)	2.0	-	-	V	
On-state current for control	$I_c$ (on)	-	-	20	$\mu A$	$V_c=2.7V$
Off-state voltage for control	$V_c$ (off)	-	-	0.8	V	
Off-state current for control	$I_c$ (off)	-	-	-0.4	mA	$V_c=0.4V$
Quiescent current	$I_q$	-	-	10	mA	$I_o=0A$

(\*4) Input voltage shall be the value when output voltage is 95% in comparison with the initial value.

(\*5) In case of opening control terminal (4th pin), output voltage turns ON.

3.3 Electrical characteristics measuring circuit

Fig. 2 Standard measuring circuit of Regulator portion

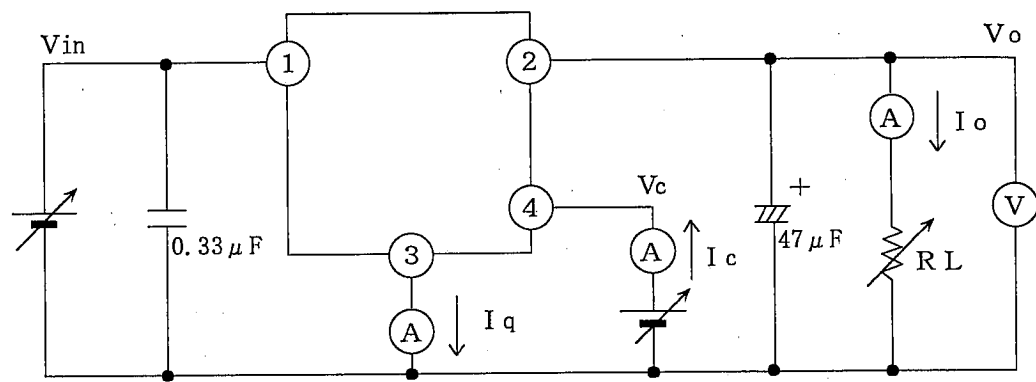
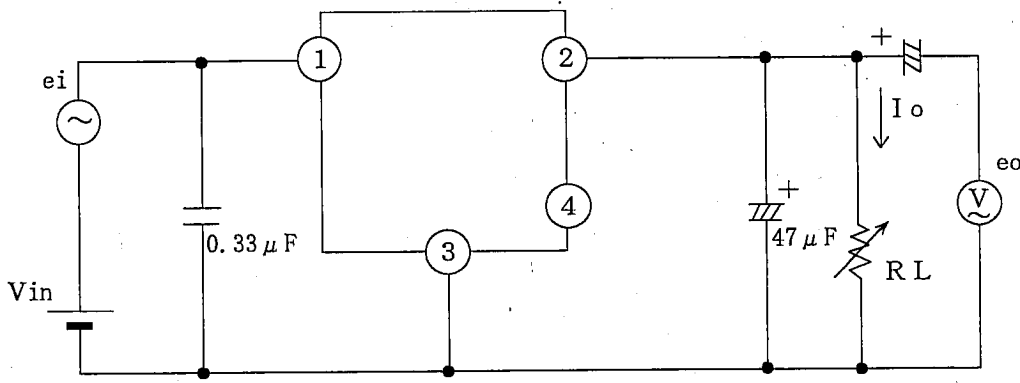

Fig. 3 Standard measuring circuit of critical rate of ripple rejection

- $f=120\text{Hz}$  sine wave
- $e_i(\text{rms})=0.5\text{V}$
- $V_{in}=7\text{V}$  (PQ05RD1BJ00H)
- $=11\text{V}$  (PQ09RD1BJ00H)
- $=14\text{V}$  (PQ12RD1BJ00H)
- $I_o=0.5\text{A}$
- $RR=20 \log(e_i(\text{rms})/e_o(\text{rms}))$





4. Reliability

The reliability of products shall satisfy items listed below.

Confidence level : 90%

LTPD : 10 or 20

Test Items	Test Conditions	Failure Judgement Criteria	Samples (n)
			Defective(C)
Temperature cycling	1 cycle -40°C(30min) to +150°C(30min) 20 cycles test	$V_o < L \times 0.8$ $V_o > U \times 1.2$ $RegL > U \times 1.2$ $RegI > U \times 1.2$ $RR < L \times 0.8$ $Vi-o > U \times 1.2$	n=22, C=0
Humidity (Steady State)	+60°C,90%RH, 1000h		n=22, C=0
Damp Heat cyclic	1 cycle : -20°C (2h) to 70°C(2h) Transfer time between high and low temp. is 1h 40 cycles test, 90%RH		n=22, C=0
High temp. storage	+150°C, 1000h		n=22, C=0
Low temp. storage	-40°C, 1000h		n=22, C=0
Operation life	Ta=25°C, Pd=1.4W, Without radiator plate,1000h		n=22, C=0
Mechanical shock	15km/s <sup>2</sup> , 0.5ms each 3 times/ ±X, ±Y, ±Z		n=11, C=0
Vibration (Variable frequency)	200m/s <sup>2</sup> , 100 to 2000 to 100Hz/4 min each 4 times/ X, Y, Z direction		U: Upper specification limit  L: Lower specification limit  n=11, C=0
Soldering heat	260°C, 10 s, Dip up to 1.5mm from resin portion *3		n=11, C=0
Electrostatic discharge	±250V, 200pF, 0Ω Between GND and each terminal/ each 3 times		n=11, C=0
Robustness of Termination (Tensile test)	Weight: 10N 30 s/ each terminal	Failure if it has breakdown and loosened pin.	n=11, C=0
Robustness of Termination (Bending test)	Weight: 2.5N 0° ~90° ~0° ~-90° ~0° each terminal *2		n=11, C=0
Solderability	245±2°C, 3 s Solder : Sn/3.0Ag/0.5Cu Use EC19S(TAMURA KAKEN Corporation made flux) *3	Failure if solder shall not be adhere at the area of 95% or more A portion.	n=11, C=0

\*1 Although color of terminals may change, this change of color is not included in criteria of failure judgement.

\*2 Terminal bending direction is shown below.

\*3 Soldering area is shown below.

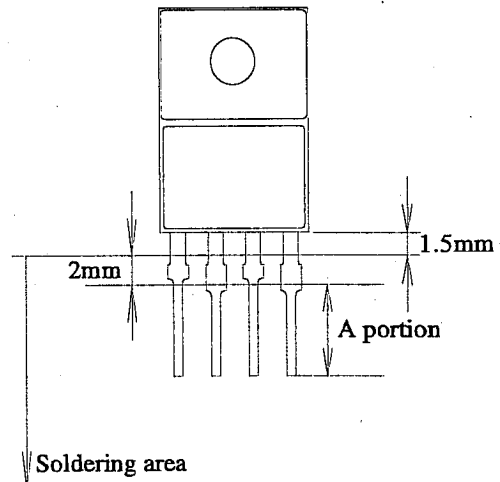
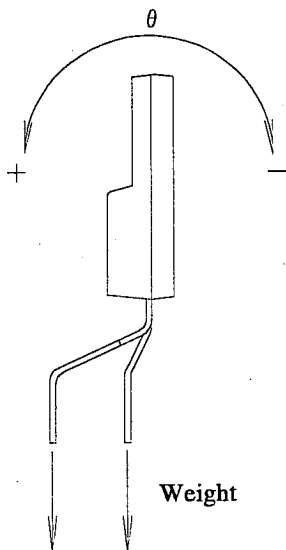

5. Outgoing inspection

TABLE II-A single sampling plans for normal inspection based on ISO 2859 is applied.  
The AQL according to the inspection items are shown below.

Defect	Inspection items	AQL (%)	Judgement criteria
Major defect	Electrical characteristics	0.1	It is based on the contents in the specification.
	Marking		To be recognized.
Minor defect	Dimensions	0.4	It is based on the contents in the specification.
	Appearance		There should not have resin break off and lead bending.

6. Supplement

6.1 Example of application

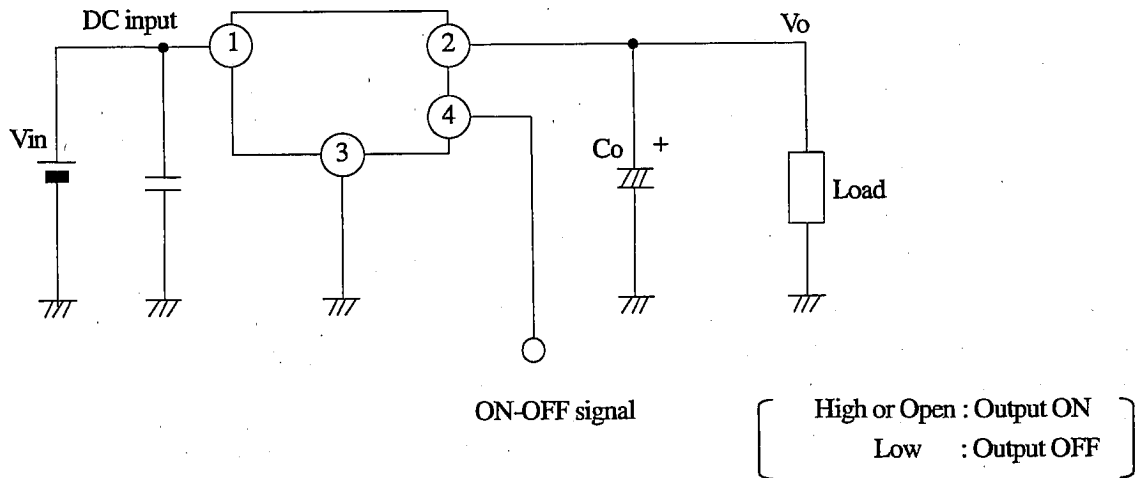

6.2 Overcurrent protection characteristics (Typical value)

(1) PQ05RD1BJ00H

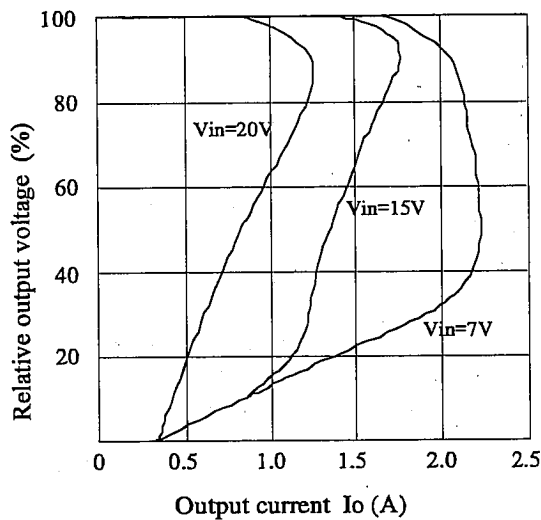

(2) PQ09RD1BJ00H

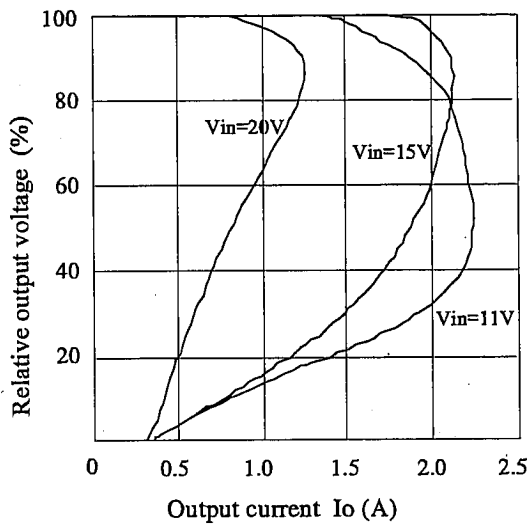

(3) PQ12RD1BJ00H

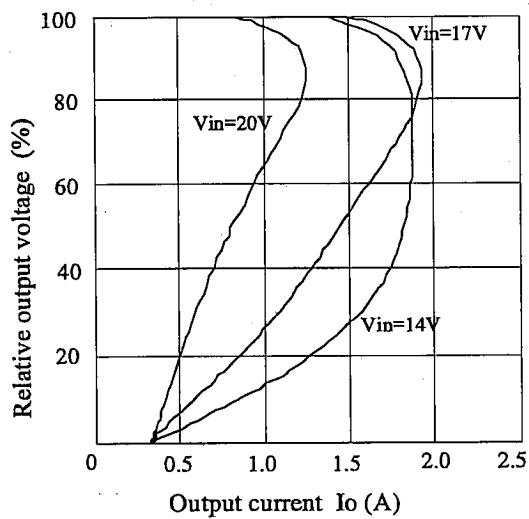

# REFERENCE

## 7. Notes

### 7.1 External connection

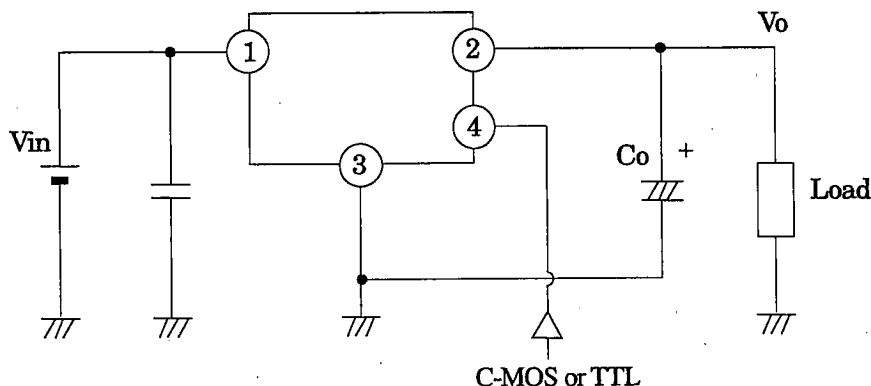

- (1) Please perform the shortest wiring for connection between  $C_o$  and the individual terminal. There is case that oscillation occurs easily by kinds of capacitor capacity and how to wire. Before you use this device, you should confirm output voltage in your actual using conditions.
- (2) The output ON/OFF control input terminal ④ is compatible with LS-TTL, and direct driving by TTL or C-MOS standard logic (RCA 4000 series) is also available. In case that ON/OFF terminal is not used, we recommend to pull up the ON/OFF terminal without resistance to input voltage.
- (3) As voltage application under conditions that the device pin is inserted divergently or reversely, may occur the degradation of characteristics or breakdown of the device, please avoid it absolutely.
- (4) In applying greater voltage to the output terminal ② than the voltage of the DC input terminal ①, breakdown of the device may occur. Especially in the case that the DC input terminal ① is short-circuited with GND, under the normal condition, the charge that is being charged into the output capacitor ( $C_o$ ) flows into the input side. This may cause breakdown of the device. In such case, please connect a silicon diode as shown below in the schematic.

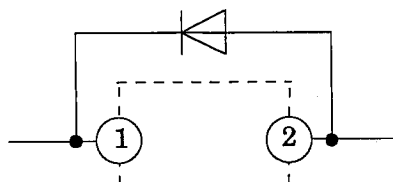

### 7.2 Mounting

- (1) Please perform processing so that mechanical stress shall not be applied to the surface of the terminal and mold resin.
- (2) Please fix the device on the heat sink with tightening torque of  $0.4$  to  $0.5\text{N} \cdot \text{m}$  by using M3 biss. At that time, please perform processing so that mechanical stress shall not be applied to the terminal and mold resin. It is recommended to use flat washer for tightening a screw. Strictly observe the following items to radiate the heat generated in the device inside effectively.
  - (a) Warp and unevenness shall not occur on the contact surface of the heat sink and device.
  - (b) Metal dust and burr shall not be attached to the contact surface of the heat sink and device.
  - (c) Uniformly apply silicon grease on the contact surface of the heat sink and device. Please select the grease having no secular alteration in the operating temperature range. And, grease to be used
    - ① No secular variation in operating temperature range.
    - ② Base oil does not separate and it does not stay in the device.
    - ③ If base oil stay in the device, operation and life time are not given bad affection.

For example, we recommend G-746; Shin-Etsu Chemical Co., Ltd. and SC-102; Toray Dow Coming Silicone Co., Ltd.

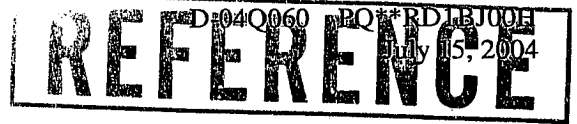

### 7.3 Thermal protection design

Internal power dissipation (Pd) of device is obtained by the following equation.

$$Pd = I_o \times (V_{in} - V_o) + V_{in} \times I_q$$

If the maximum operating temperature and Pd when the element is operating are determined, use such a heat sink as allows the element to operate within the safety operation area specified by the degrading curve in Fig. 1. Insufficient radiation or in case of using exceeding the internal power dissipation curve gives an unfavorable influence to the normal operation and reliability of the device.

In the case of no passage within the safety operational territory illustrated by the degrading curve, the overheat protection circuit operates to let output fall down, please avoid keeping such condition for a long time.

### 7.4 Static electricity

Good caution must be exercised against static electricity since this device consists of a bipolar IC.

Following are some examples of preventive measures against excessive voltages such as caused by static electricity.

- (a) Human body must be grounded to discharge the static electricity from the body or cloth.
- (b) Anything that is in contact with the device such as workbench, inserter, or measuring instrument must be grounded.
- (c) Use a solder dip basin with a minimum leak current (isolation resistance 10M $\Omega$  or more) from the commercial power supply. Also the solder dip basin must be grounded.

### 7.5 For cleaning

- (1) Solvent cleaning : Solvent temperature 45 $^{\circ}$ C or less  
Immersion for 3 min or less
- (2) Ultrasonic cleaning : The effect to device by ultrasonic cleaning differs by cleaning bath size, ultrasonic power output, cleaning time, PCB size or device mounting condition etc.  
Please test it in actual using condition and confirm that doesn't occur any defect before starting the ultrasonic cleaning.
- (3) Applicable solvent : Ethyl alcohol, Methyl alcohol, Isopropyl alcohol  
When the other solvent is used, there are cases that the packaging resin is eroded.  
Please use the other solvent after thorough confirmation is performed in actual using condition.

### 7.6 Storage environment

The products shall be stored at the temperature 5 to 30 $^{\circ}$ C and the humidity lower than 70%RH.  
Regarding the devices stored for long time, there is possibility that deterioration of lead pin color and solderability may occur. Please use the devices after checking the solderability in advance.