

PQ1CY1032ZxH

To-263 Surface Mount Type
Chopper Regulator

■ Features

1. Maximum switching current: 3.5A
2. Built-in ON/OFF control function
3. Built-in soft start function to suppress overshoot of output voltage in power on sequence or ON/OFF control sequence
4. Built-in oscillation circuit (Oscillation frequency: TYP. 150kHz)
5. Built-in overheat protection function, overcurrent shut-down function
6. TO-263 package
7. **PQ1CY1032ZZH**: Sleeve-packaged product
PQ1CY1032ZPH: Tape-packaged product
8. Variable output voltage
(Output variable range: V_{ref} to $35V$ / $-V_{ref}$ to $-30V$)
[Possible to select step-down output/inverting output according to external connection circuit]
9. RoHS directive compliant

■ Applications

1. LCD monitors
2. Car navigation systems
3. Switching power supplies

■ Absolute Maximum Ratings

(Ta=25°C)

Parameter	Symbol	Rating	Unit
*1 Input voltage	V_{IN}	40	V
Error input voltage	V_{ADJ}	7	V
Input - output voltage	V_{I-O}	41	V
*2 Output - COM voltage	V_{OUT}	-1	V
*3 V_{soft} terminal voltage	V_{soft}	-0.3 to +40	V
Switching current	I_{SW}	3.5	A
*4 Power dissipation	P_D	35	W
*5 Junction temperature	T_j	150	°C
Operating temperature	T_{opr}	-20 to +85	°C
Storage temperature	T_{stg}	-40 to +150	°C
Soldering temperature	T_{sol}	260(10s)	°C

*1 Voltage between V_{IN} terminal and COM terminal*2 Voltage between V_{OUT} terminal and COM terminal*3 Voltage between V_{SOFT} terminal and COM terminal*4 P_D : With infinite heat sink*5 There is case that over heat protection function operates at the temperature $T_j=125^{\circ}\text{C}$ to 150°C , so this item cannot be used in this temperature range.

■ Outline Dimensions

(Unit:mm)

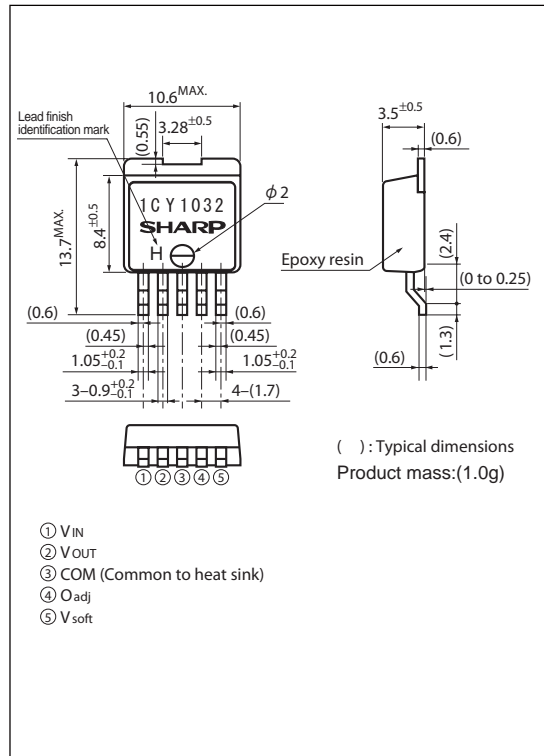
Lead finish: Lead-free solder plating
(Composition: Sn2Cu)

Notice The content of data sheet is subject to change without prior notice.

In the absence of confirmation by device specification sheets, SHARP takes no responsibility for any defects that may occur in equipment using any SHARP devices shown in catalogs, data books, etc. Contact SHARP in order to obtain the latest device specification sheets before using any SHARP device.

Sheet No.: OP06039

www.DataSheet4U.com

Electrical Characteristics

(Unless otherwise specified, condition shall be $V_{IN}=12V, I_o=0.5A, V_o=5V, V_{soft}$ terminal=0.1 μ F, $T_a=25^\circ C$)

Parameter	Symbol	Conditions	MIN.	TYP.	MAX.	Unit
Output saturation voltage	V_{SAT}	$I_{SW}=3A$	—	1.4	1.8	V
Reference voltage	V_{ref}	—	1.235	1.26	1.285	V
Reference voltage temperature fluctuation	ΔV_{ref}	$T_j=0$ to $125^\circ C$	—	± 0.5	—	%
Load regulation	$ R_{regL} $	$I_o=0.5$ to $3A$	—	0.2	1.5	%
Line regulation	$ R_{reg} $	$V_{IN}=8$ to $35V$	—	1	2.5	%
Efficiency	η	$I_o=3A$	—	80	—	%
Oscillation frequency	f_o	—	135	150	165	kHz
Oscillation frequency temperature fluctuation	Δf_o	$T_j=0$ to $125^\circ C$	—	± 2	—	%
Overcurrent detecting level	I_L	Switching current peak	3.6	4.2	5.8	A
Charge current	I_{CHG}	②,④ terminals is open,⑤ terminal	—	-10	—	μA
Input threshold voltage	V_{THL}	Duty ratio=0%,④ terminal=0V,⑤ terminal	—	1.3	—	V
	V_{THH}	Duty ratio=100%,④ terminal is open,⑤ terminal	—	2.3	—	V
ON threshold voltage	$V_{TH(ON)}$	④ terminal=0V,⑤ terminal	0.7	0.8	0.9	V
Overcurrent shutdown threshold voltage	V_{THIL}	⑤ terminal	3.8	4.6	5.5	V
Stand-by current	I_{SD}	$V_{IN}=40V,⑤$ terminal=0V	—	140	400	μA
Output OFF-state dissipation current	I_{QS}	$V_{IN}=40V,⑤$ terminal=0.9V	—	8	16	mA

Fig.1 Test Circuit

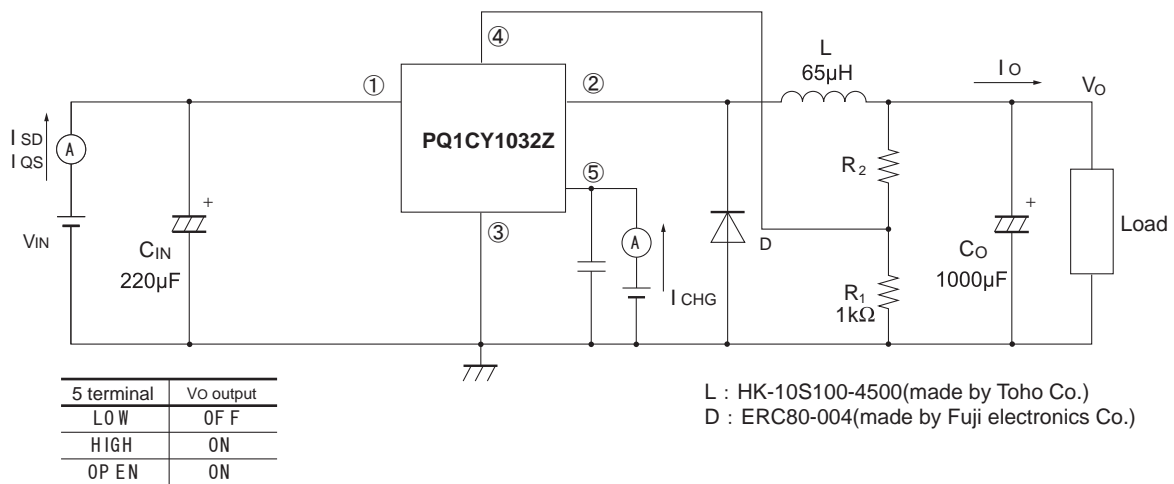
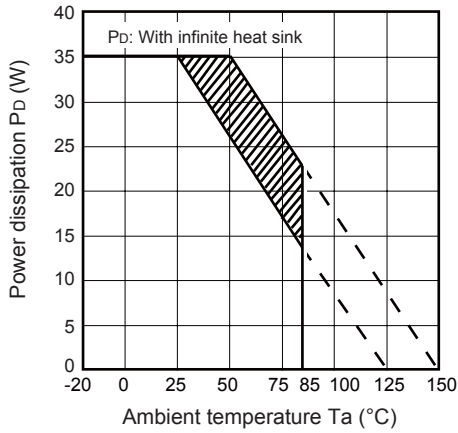

Fig.2 Power Dissipation vs.Ambient Temperature



Note) Oblique line portion:Overheat protection may operate in this area.

Fig.3 Overcurrent Protection Characteristics (Typical Value)

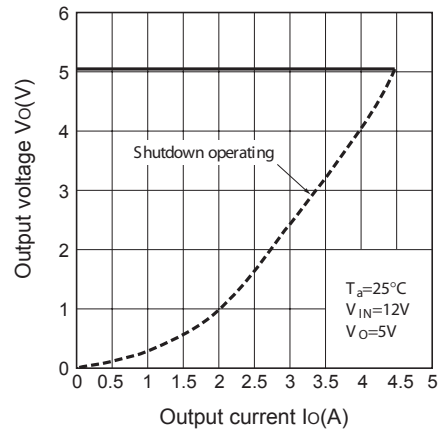

Fig.4 Efficiency vs. Input Voltage

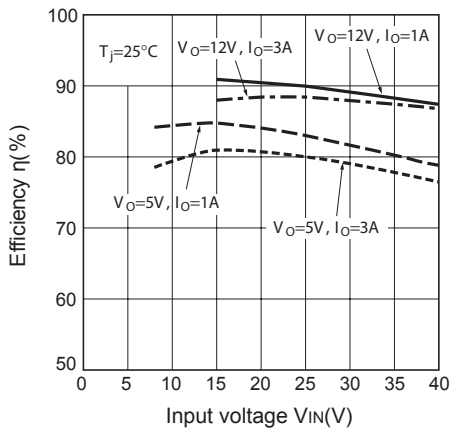

Fig.5 Switching Current vs. Output Saturation Voltage

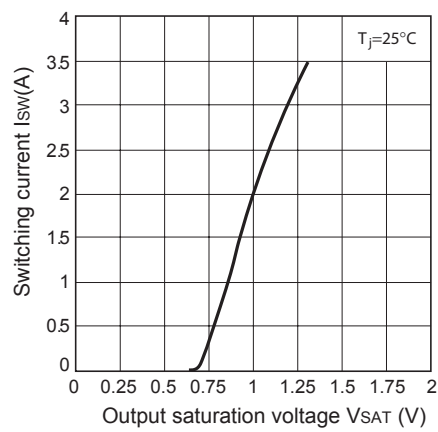

Fig.6 Operating Dissipation Current vs. Input Voltage

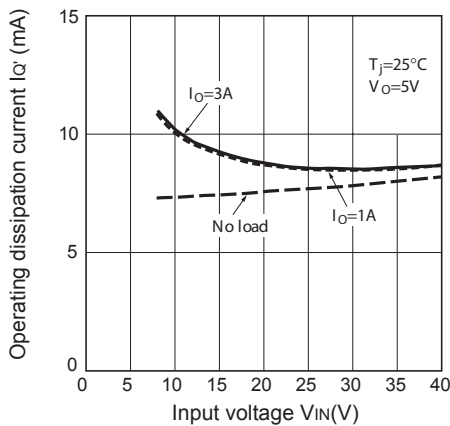

Fig.7 Reference Voltage Fluctuation vs. Junction Temperature

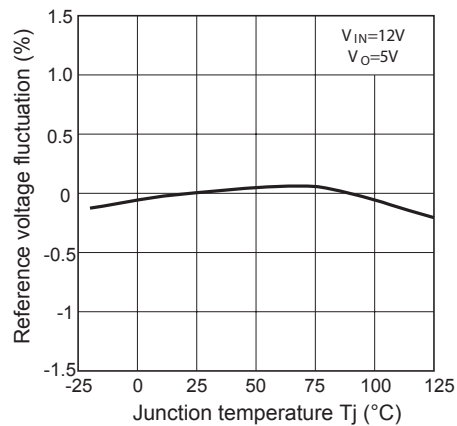

Fig.8 Load Regulation vs. Output Current

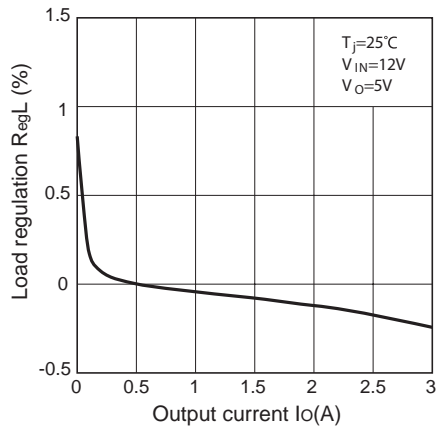

Fig.9 Line Regulation vs. Input Voltage

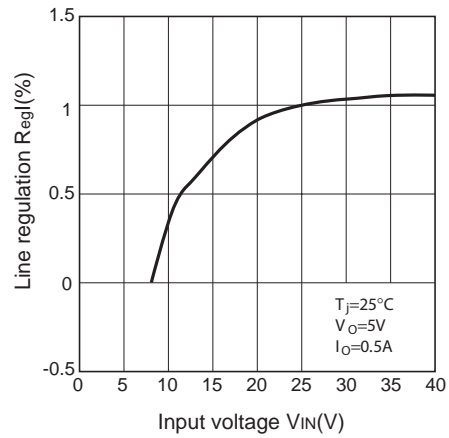

Fig.10 Oscillation Frequency Fluctuation vs. Junction Temperature

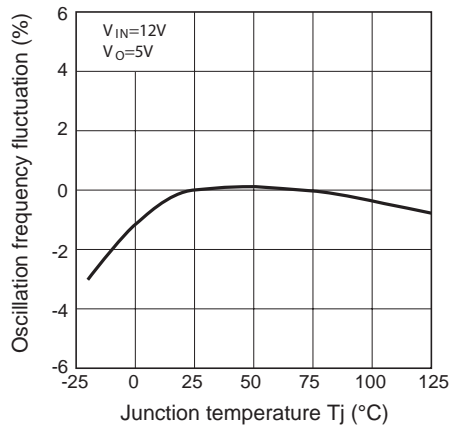

Fig.11 Overcurrent Detecting Level Fluctuation vs. Junction Temperature

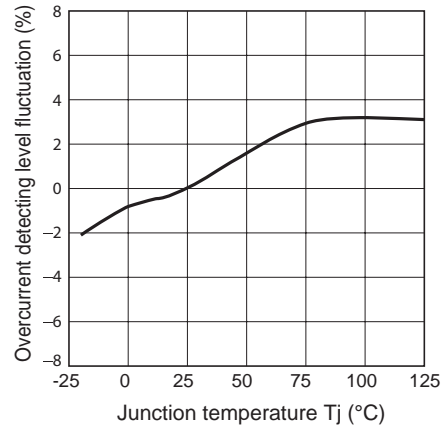

Fig.12 On Threshold Voltage vs. Junction Temperature

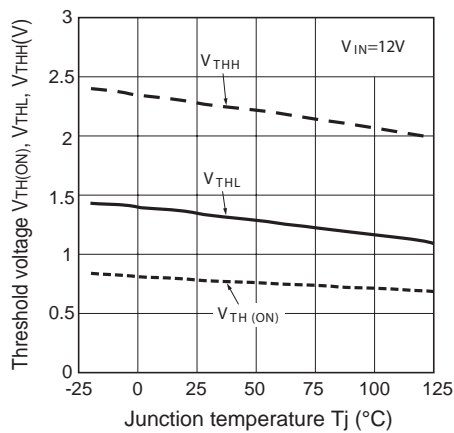

Fig.13 Overcurrent Shutdown Threshold Voltage vs. Junction Temperature

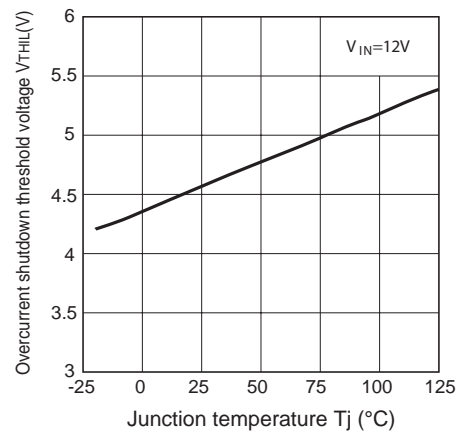

Fig.14 Power Dissipation vs. Ambient Temperature (Typical Value)

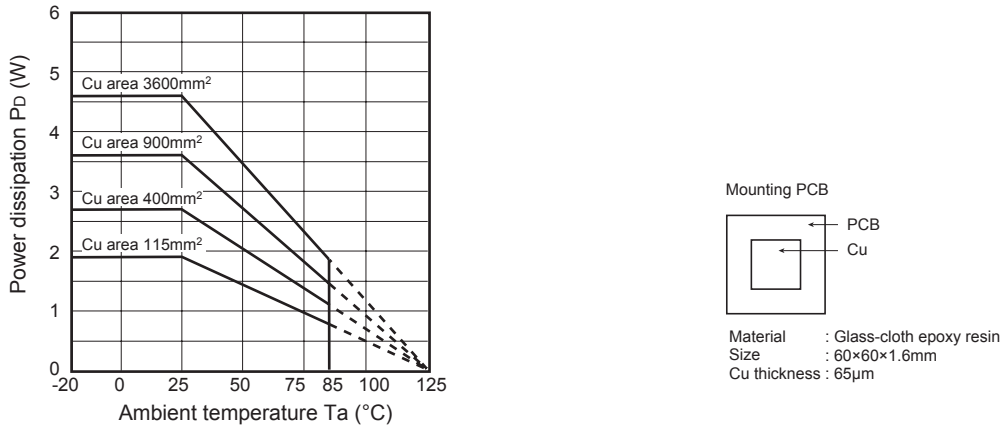

Fig.15 Block Diagram

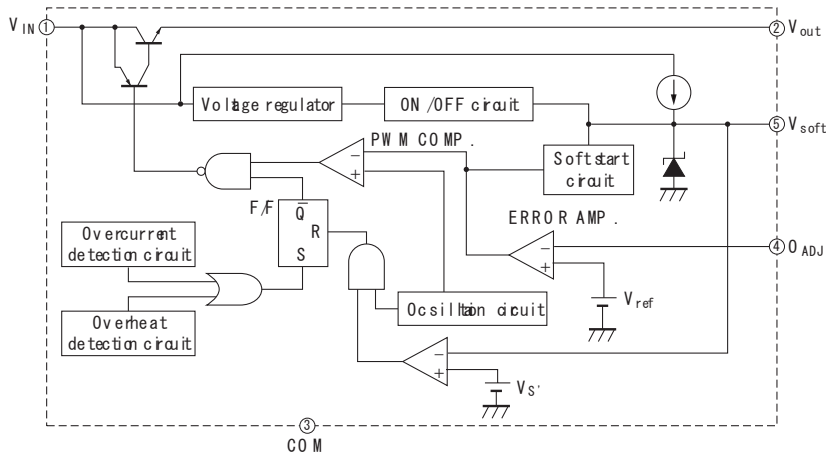

Fig.16 Step Down Type Circuit Diagram

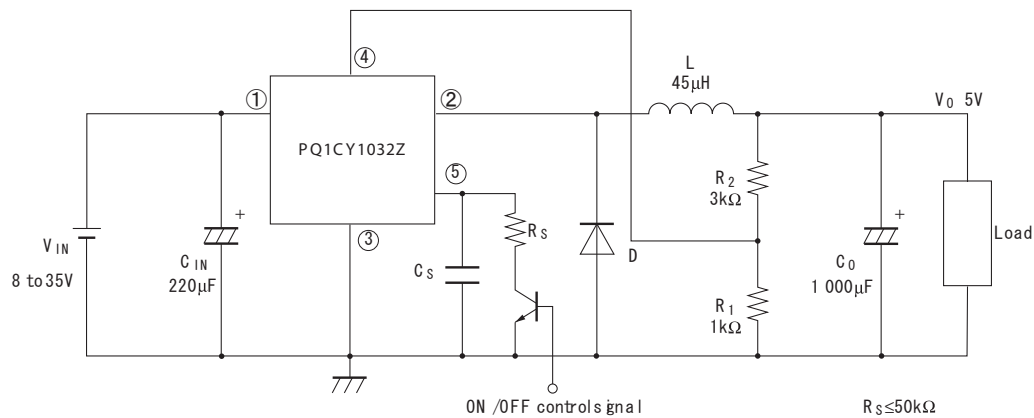
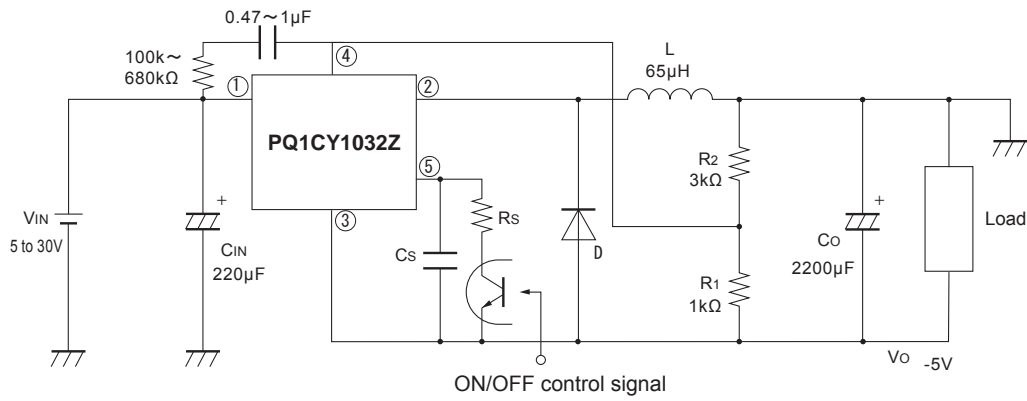

Fig.17 Polarity Inversion Type Circuit Diagram



In case of polarity is reverse, depending on the conditions, there is cases that output voltage can not gain, please use this device after confirming the output voltage at the actual conditions.