

PQ2016 SERIES POWER TRANSFORMER MODULES

PRODUCT OVERVIEW:THT POWER TRANSFORMERS

Characteristics

High insulation type High efficiency
IEC60950 Compatible
Operating temperature range:-40°C to +85°C

Applications

Lighting
CMC
industrial Controls
White Goods
Telecom
DC/DC Converter



Bobbin Winding Area

Width(mm)	Build(mm)	Perimeter(mm)
7.9	3.12	34.5

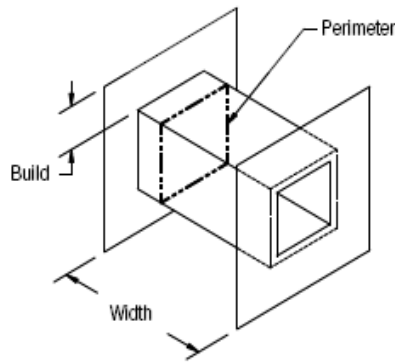

CORE DATA

Ae (mm ²)	Ve (mm ³)	Le (mm)
62	2318.3	37.4

POWER LEVEL (W)

Flyback	Forward	Push-pull
19	28	56

Test frequency:100KHz

THT Vertical

Dimensions & Footprint

