

PQ3220 SERIES POWER TRANSFORMER MODULES

PRODUCT OVERVIEW:THT POWER TRANSFORMERS

Characteristics

High insulation type High efficiency
 IEC60950 Compatible
 Operating temperature range:-40°C to +85°C

Applications

Lighting
 CMC
 industrial Controls
 White Goods
 Telecom
 DC/DC Converter



Bobbin Winding Area

Width (mm)	Build (mm)	Perimeter (mm)
9.08	5.18	50.3

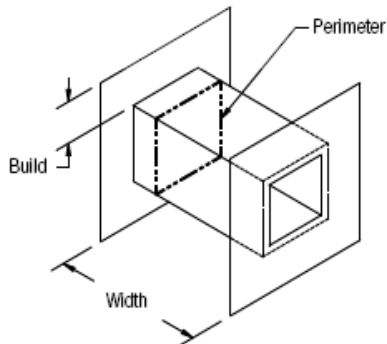

CORE DATA

Ae (mm ²)	Ve (mm ³)	Le (mm)
169	9447	55.9

POWER LEVEL (W)

Flyback	Forward	Push-pull
88	132	264

Test frequency:100KHz

THT Vertical

Dimensions & Footprint

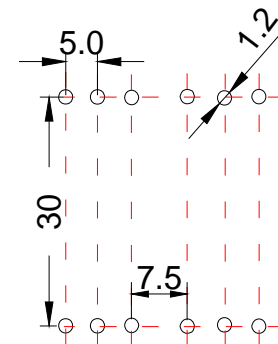
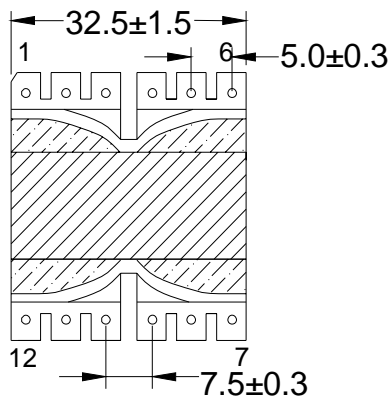
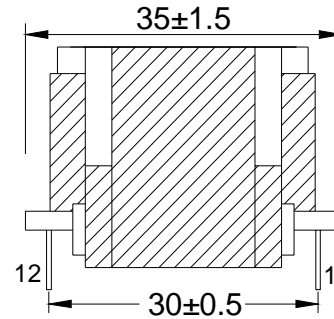
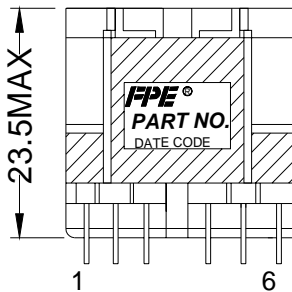

SUGGESTED PAD LAYOUT