

## Low Voltage Boost Driver PR4404 for 0.5W / 1W Power LEDs

The PR4404 is a step-up converter for white LEDs, operating with single battery cell supply (1.2/1.5V) at up to 150mA LED current or dual cell supply (2.4/3.0V) at up to 300mA LED current.

A minimum part count allows compact and cost-efficient solutions.

The converter can be switched on and off with a logic signal, which is useful e.g. for PWM control, timer circuits etc.

### Features

- minimum startup voltage 1.0V
- supply by one or two battery cells
- low number of external components
- battery deep discharge protection

### Applications

- LED torches
- LCD panel backlighting
- home lighting
- toys

### Typical Application Circuit

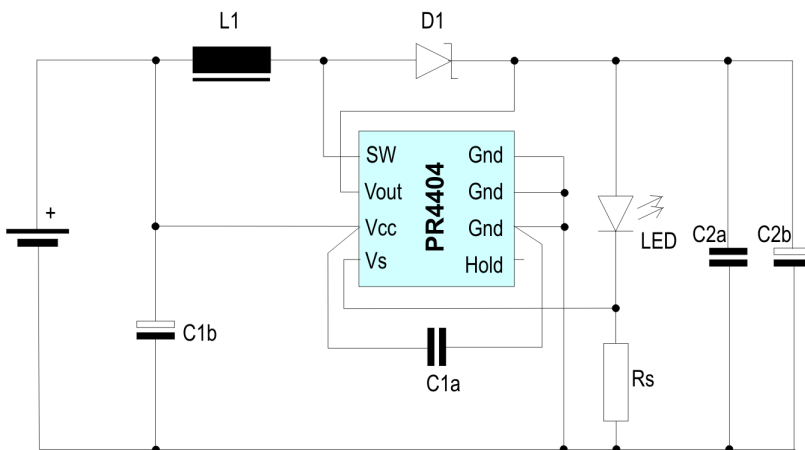

### Pin Description PR4404

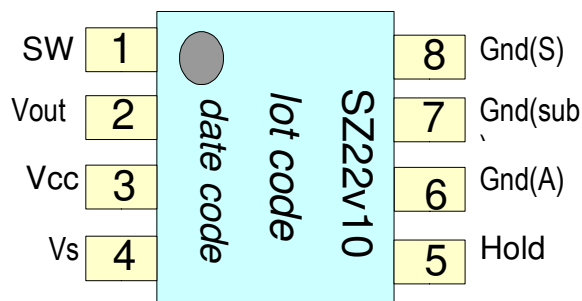

Pin No	Pin Name	Pin Function Description
1	SW	driver output
2	Vout	output voltage, rectified
3	Vcc	battery supply input
4	Vs	LED cathode / current sense resistor
5	Hold	shutdown
6	Gnd (A)	ground (analog)*
7	Gnd (sub)	ground (substrate)*
8	Gnd (S)	ground (power)*

\*Pins 6, 7, 8 must all be connected.

## Block Diagram

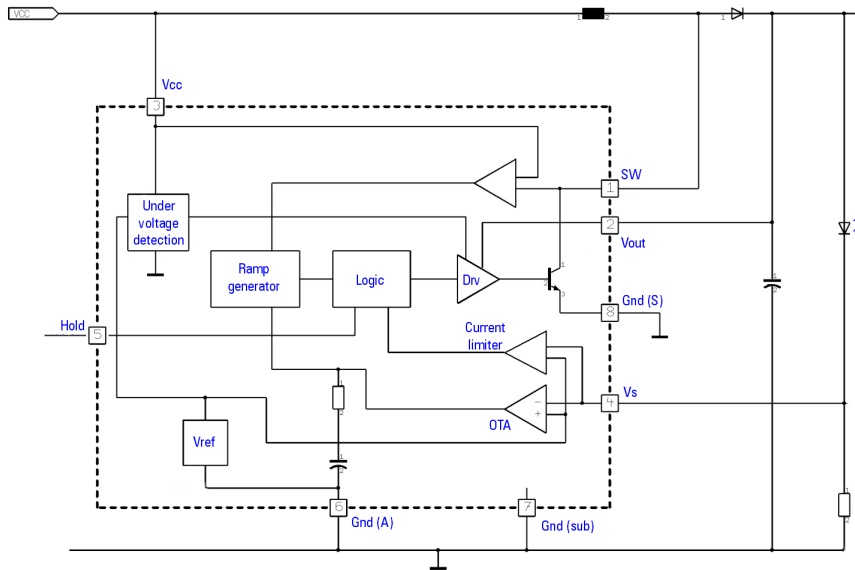

## Absolute Maximum Ratings

Parameter	Min	Typ	Max	Units
V <sub>CC</sub> (no damage)	-0.3		8	V
SW output peak current			1.5	A
Operating junction temperature	-20		125	°C
Storage Temperature Range	-55		150	°C
Electrostatic Discharge (ESD) Protection	2			kV

## Electrical Characteristics

T<sub>a</sub> = 25°C, unless otherwise noted.

Symbol	Parameter	Conditions	Min	Typ	Max	Units
V <sub>CC</sub>	Supply Voltage, min. operating min. startup max. operating		0.89	1.00	1.05 5.0*	V V V
V <sub>sat</sub>	SW output transistor saturation	1.0A			0.4	V
f <sub>sw</sub>	Switching Frequency		300		700	kHz
V <sub>FB</sub>	Feedback voltage threshold at V <sub>s</sub>			200		mV
	Quiescent supply current	Hold = LOW V <sub>CC</sub> > 850mV		2.0	3.0	mA
I <sub>CC</sub>	Supply current	Hold = open V <sub>CC</sub> > 850mV		2.0	3.0	mA
V <sub>SW Clamp</sub>	SW output clamping voltage		14			
Θ <sub>JA</sub>	Thermal resistance junction - ambient	no air convection		160		K/W

\* but V<sub>CC</sub> not higher than V<sub>F</sub> (LED)

## Typical Characteristics

This datasheet presents characteristics for different typical applications:

- A. Supply voltage 1...2V - target current 100mA - one LED
- B. Supply voltage 1...2V - target current 150mA - one LED
- C. Supply voltage 1.5...3V - target current 300mA - one LED
- D. Supply voltage 2...5V - target current 200mA - two LEDs in series

A and B are typical single battery-cell applications, C for two, and D for three cells. The behaviour at many other operating conditions can be estimated by interpolation or extrapolation.

Note that in the following diagrams the peak current through the output switch exceeds the maximum rating.

Also the power dissipation can cause a junction temperature higher than the maximum rating under some operating conditions.

These data should give an impression of the performance over the whole set of parameters, but the fact that they are shown here should not be regarded as an approval for operation under these conditions.

### Test circuit

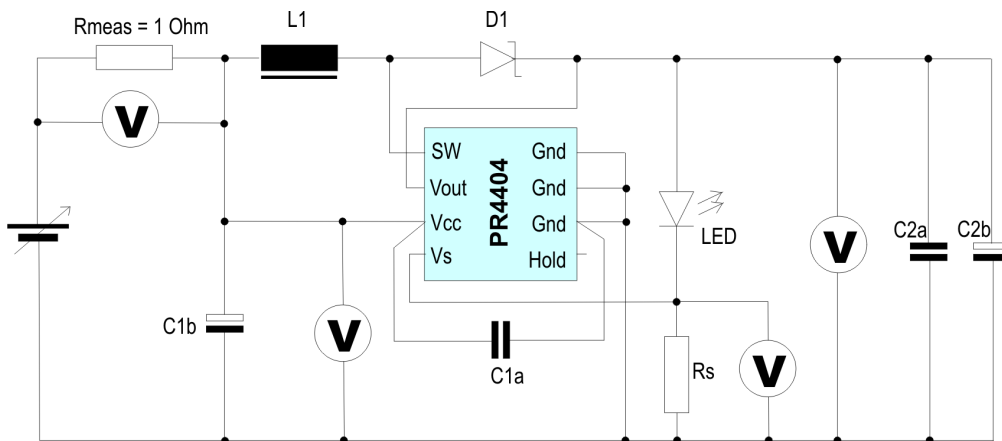

- C1a: 1 $\mu$ F ceramic
- C1b: 100 $\mu$ F tantalum
- L1: Würth WE-PD XS series; inductance see diagrams
- D1: MBR5140
- Rs: see diagrams
- C2a: 1 $\mu$ F ceramic
- C2b: 100 $\mu$ F tantalum

## A. Supply voltage 1...3V - target current 100mA - one LED

$R_s = 2 \Omega$  ,  $L1 = 1.0\mu\text{H} / 1.5\mu\text{H}$  with  $I_{\text{sat}}=2.5\text{A}$

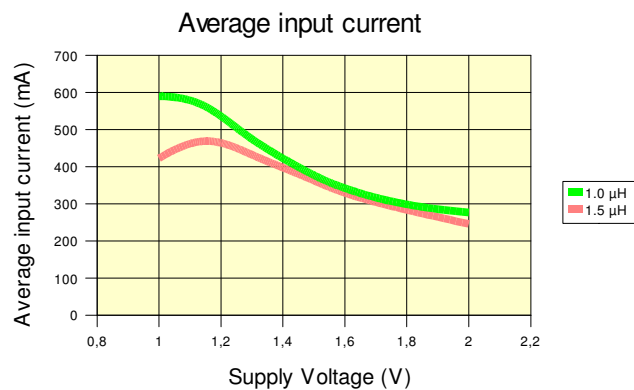
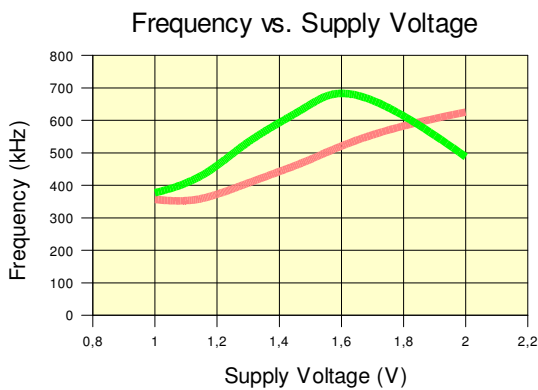
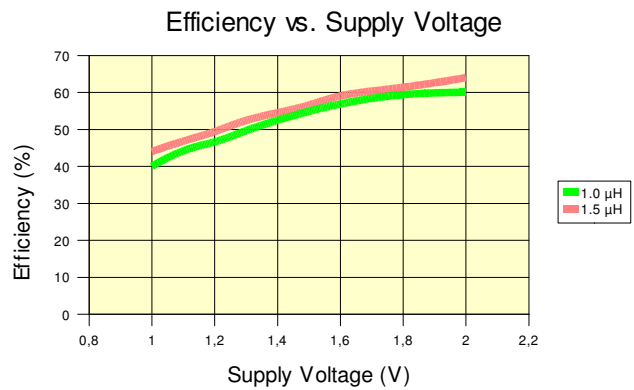
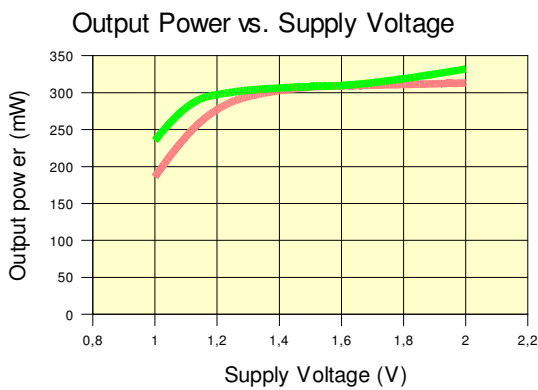
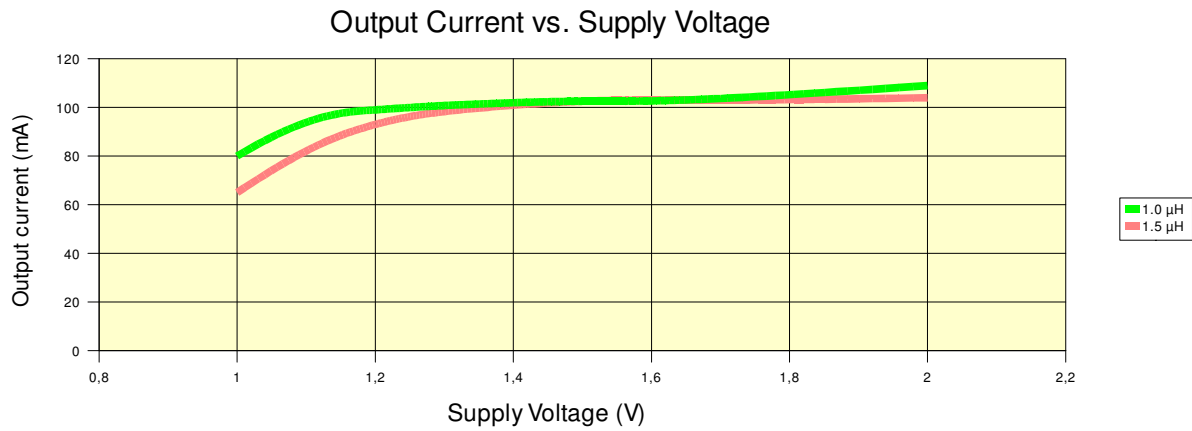

For best operation at supply voltages between 1.0 and 1.6V the 1.0μH inductance is the best choice, while at higher voltages 1.5μH are recommended. Generally, the peak input current is approximately twice the average input current.

## B. Supply voltage 1...2V - target current 150mA - one LED

$R_s = 1.33 \Omega$  ,  $L1 = 1.0\mu\text{H} / 1.5\mu\text{H}$  with  $I_{\text{sat}}=2.5\text{A}$

Output Current vs. Supply Voltage

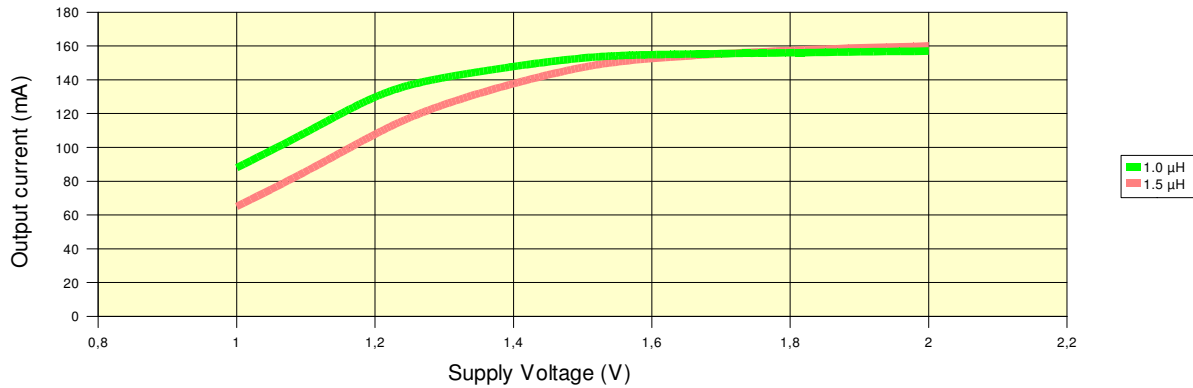

Output Power vs. Supply Voltage

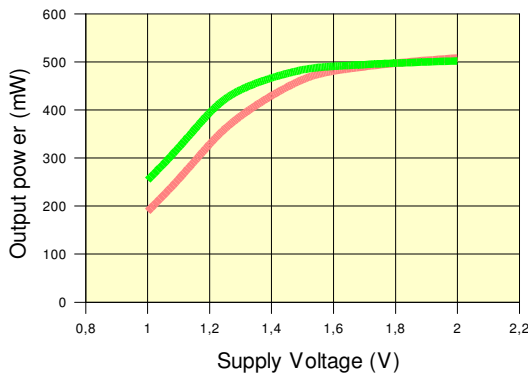

Efficiency vs. Supply Voltage

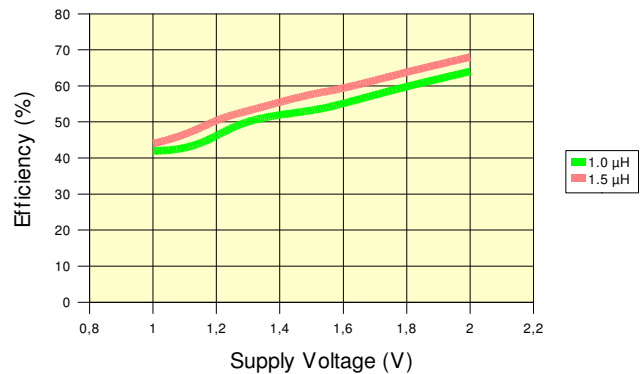

Frequency vs. Supply Voltage

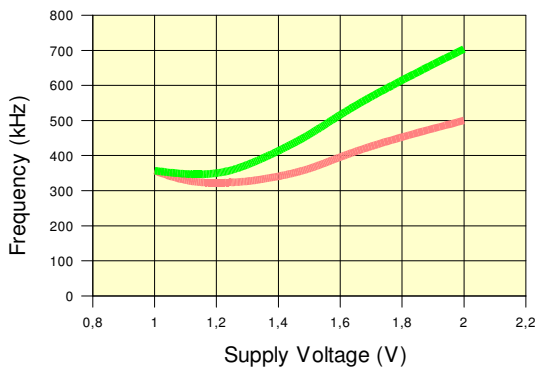

Average input current

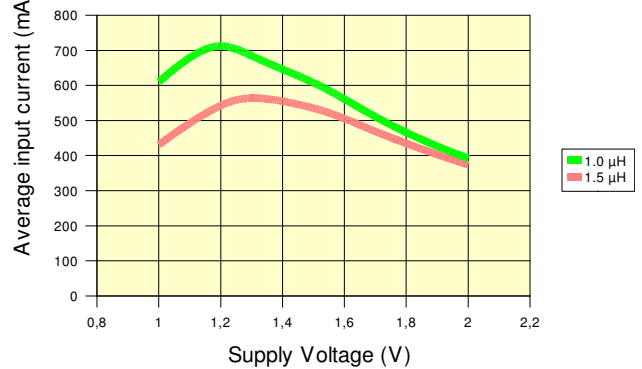

The peak input current is approximately twice the average input current. At some conditions this current is close to the SW current maximum rating. The allowed ambient temperature range is restricted by the maximum junction temperature rating!

## C. Supply voltage 1.5...3V - target current 300mA - one LED

$R_s = 0.67 \Omega$  ,  $L1 = 1.5\mu\text{H} / 2.2\mu\text{H}$  with  $I_{\text{sat}}=2.5\text{A}$

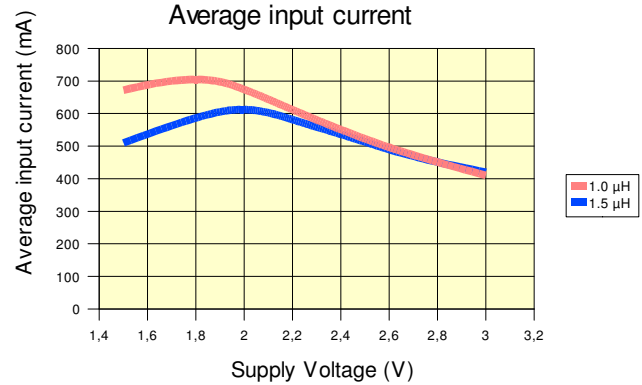
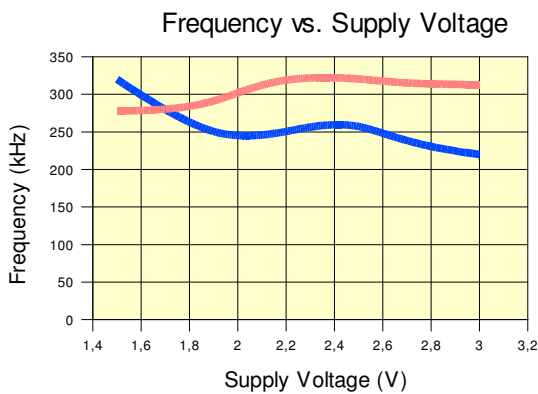
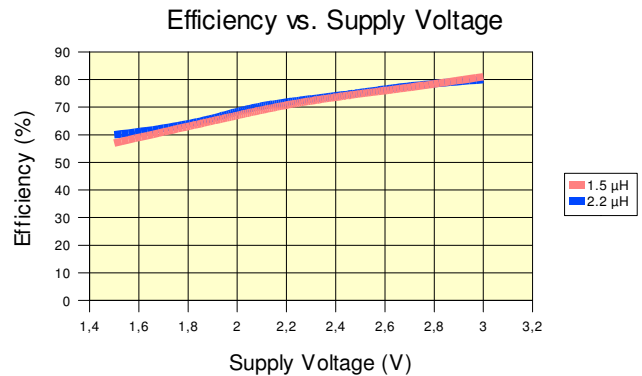
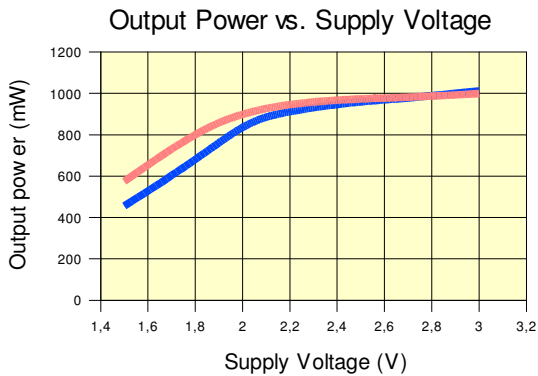
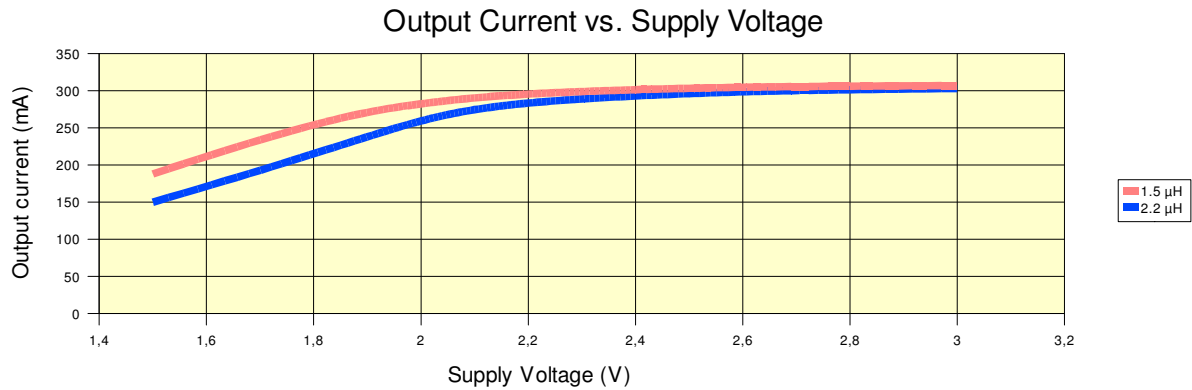

The peak input current is approximately twice the average input current.  
 At some conditions this current is close to the SW current maximum rating.  
 The allowed ambient temperature range is restricted by the maximum junction temperature rating!

## D. Supply voltage 2...5V - target current 200mA - two LEDs in series

$R_s = 1 \Omega$  ,  $L1 = 1.5\mu\text{H} / 2.2\mu\text{H} / 3.3\mu\text{H}$  with  $I_{\text{sat}}=2.5\text{A}$

Output Current vs. Supply Voltage (2 LEDs in series)

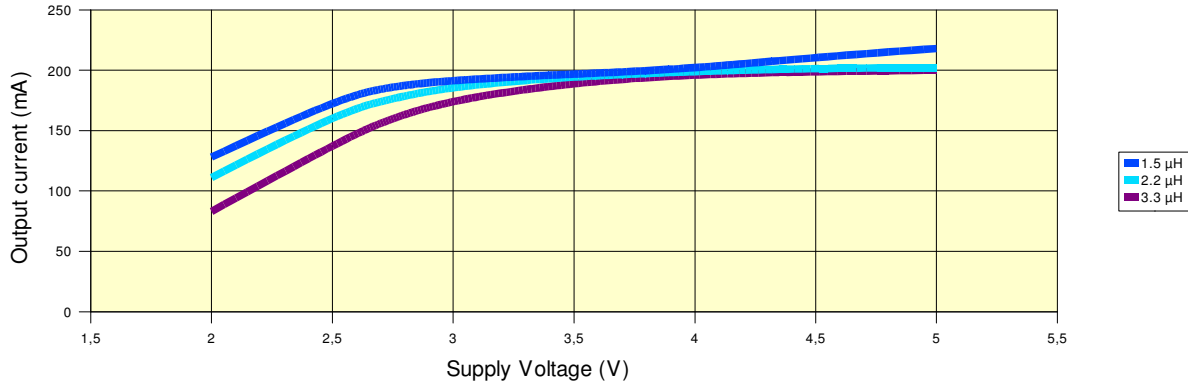

Output Power vs. Supply Voltage

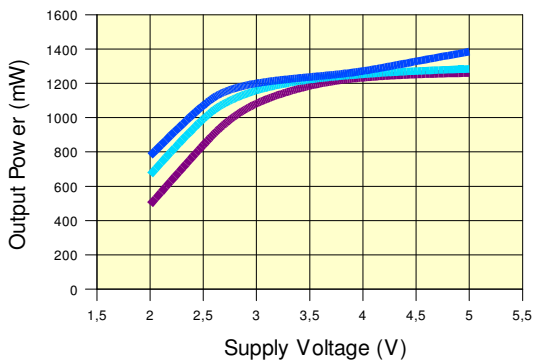

Efficiency vs. Supply Voltage

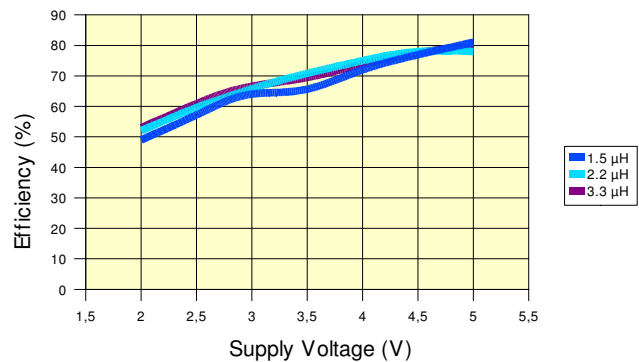

Frequency vs. Supply Voltage

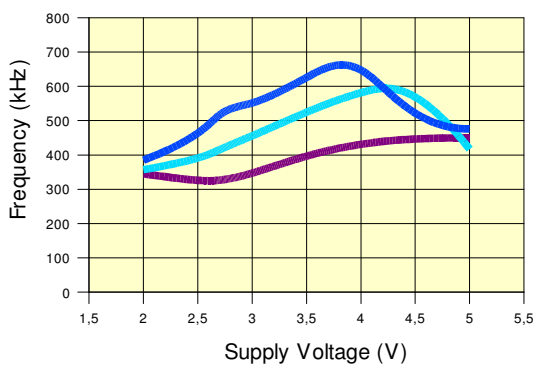

Mean input current

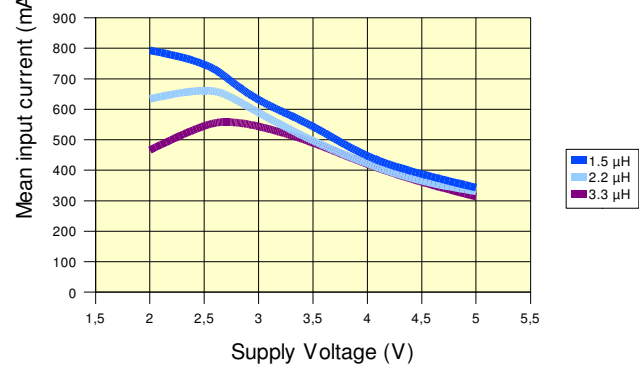

As PR4404 is a boost converter, input voltages higher than the LED forward voltage require two or three LEDs in series at the output. With two LEDs in series, a stable output current of 200mA, or an output power of 1.2W, can be achieved in the voltage range between 3.5V and 5V, which is interesting for three battery cell applications. Operation with a 2.2μH yields optimum results with best margins. High input currents that occur at low input voltages can thermally overload the IC.

## Application Notes

### *General dimensioning guidelines*

#### **Current sense resistor Rs**

Rs sets the peak output current, which is defined by  $I_{\text{peak}} = V_{\text{FB}} / R_s$ .

#### **Inductor L1**

The best inductance depends mainly on the ratio between input and output voltage. A high inductance results in a low frequency, limiting the transferred power at low supply voltages.

A low inductance causes a shorter charging time, allowing a higher power transfer, but resulting in a lower efficiency and eventually in an insufficient current regulation at higher supply voltages.

So a proper balance between behaviour at the low end and high end of the supply voltage range in the respective application should be found.

See diagrams and application examples for some recommendations.

The saturation current of the inductor must be at least equal to the peak current. The peak current is approximately two times the average input current under worst-case conditions, which mostly occur at low supply voltages.

#### **Schottky diode D1**

D1 must be capable driving the peak current, as for the inductor.

A low forward voltage at this current and a fast recovery provide a high efficiency.

Recommended diode types are MBRS140 or 1N5817.

#### **LED**

Any type of LED can be used, as far as specified for the current.

However, the output voltage  $V_{\text{out}}$  must be higher than the input voltage  $V_{\text{cc}}$ ; otherwise the current regulation will not work properly. Therefore it is usually possible to drive one white-light LED with  $V_f = 3.2\text{V}$  from two alkaline batteries with a nominal voltage of  $3.0\text{V}$ , but not from three NiMH cells with  $3.6\text{V}$ .

The voltage at pin SW is internally clamped by a zener diode (for clamping voltage see electrical specification). Therefore operation without output load does not damage the chip. Nevertheless, prolonged operation without load should be avoided.

It is possible to connect two or more LEDs in series at the output. With increasing ratio of  $V_{\text{out}}/V_{\text{cc}}$  the maximum output current decreases.

Mind that the built-in zener diode at SW limits the achievable output voltage and therefore the number of LEDs that can be connected.

#### **Capacitors C1, C2**

C1 is a reservoir capacitor to stabilise the input voltage and prevent regulator oscillations. It usually consists of a ceramic capacitor C1a in parallel to a tantalum capacitor C1b. It is important to connect a ceramic capacitor of approx.  $1\mu\text{F}$  between  $V_{\text{cc}}$  and Gnd very close to the IC.

The size of the tantalum or electrolytic capacitor depends on the application. In some cases it may be even dispensable, but mostly a capacitor of up to  $100\mu\text{F}$  will improve the



performance, as it smoothes out the peak current drain from the power source and allows a battery to be used to a deeper discharge level.

Also C2 consists of a ceramic capacitor C2a and an electrolytic reservoir capacitor C2b at the output, responsible for smoothing the pulsating output current through diode D1. Its value depends on the current level and the allowed ripple height. Find some recommended values in the application example circuits.

## PCB

When designing the PCB layout, keep in mind that currents of up to 2A are involved. All power lines, especially from the battery, inductor and SW input pin, must be sufficiently wide to keep the voltage drop as low as possible.

The ceramic capacitor C1b must be placed close between Vcc and Gnd of the IC.

A large ground plane is helpful for good performance and low EMI.

## Power Flashlight

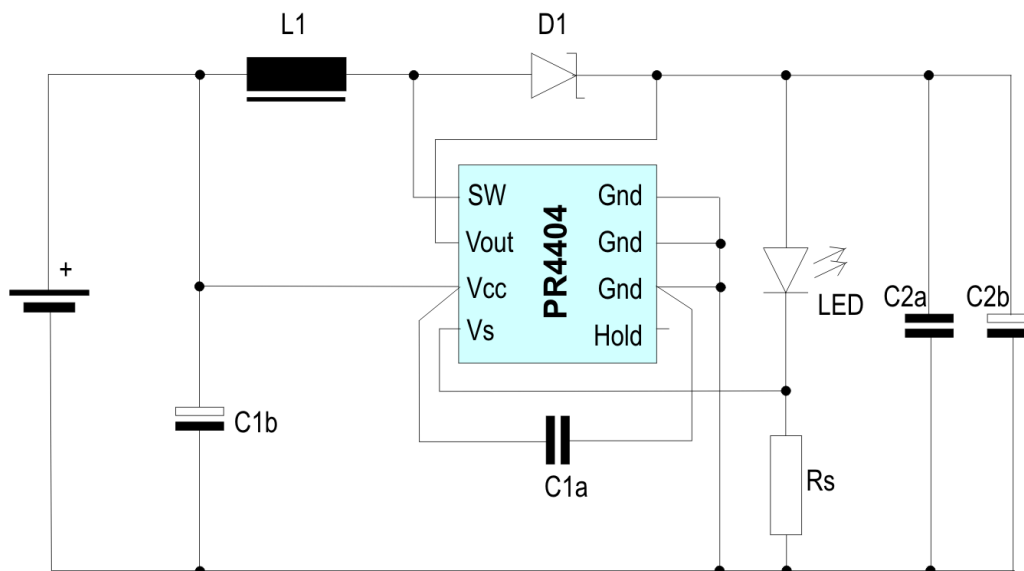

### Components:

for LED current 150mA:

Vcc: 1.2...1.5V (nominal)  
 C1a: 1 $\mu$ F  
 C1b: 100 $\mu$ F/6.3V  
 L1: 1.0 $\mu$ H, Isat  $\geq$  1.2A  
 D1: MBRS140 or 1N5817  
 Rs: 1.3  $\Omega$   
 C2a: 470nF  
 C2b: 22 $\mu$ F/6.3V

for LED current 300mA:

Vcc: 2.4...3.0V (nominal)  
 C1a: 470nF  
 C1b: 100 $\mu$ F/6.3V  
 L1: 1.5 $\mu$ H, Isat  $\geq$  1.6A  
 D1: MBRS140 or 1N5817  
 Rs: 0.67  $\Omega$   
 C2a: 470nF  
 C2b: 22 $\mu$ F/6.3V

## Driving a chain of LEDs

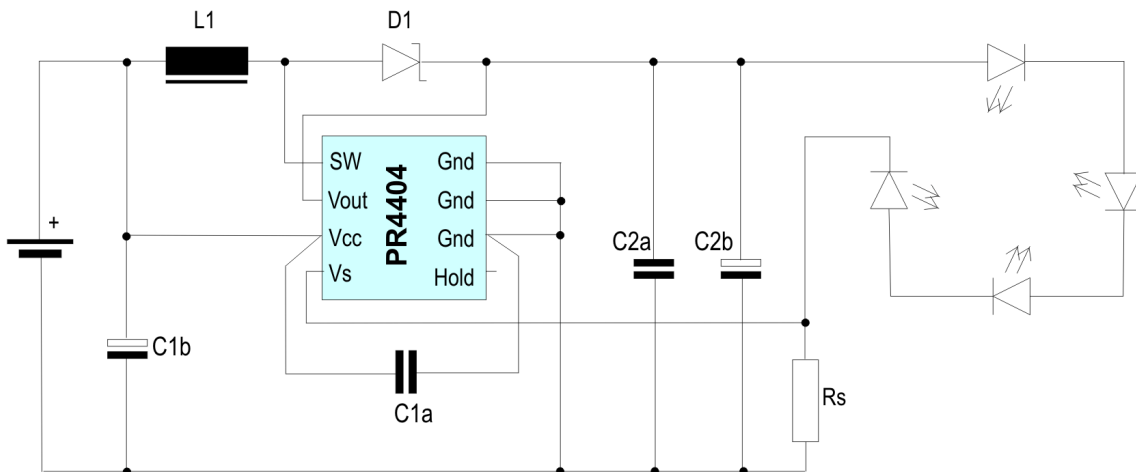

Output voltages up to 16V are possible. As the output power of the circuit is limited, the maximum LED current is lower by a factor roughly equal to the number of LEDs compared with single LED applications.

Recommended dimensions: see power flashlight, except  $R_s$  changed to  $V_{FB}/I_{LED}$ .

## PWM controlled LED

The Hold input allows to switch on and off the LED with a digital circuit, such as a microcontroller or a timer circuit.

This can be used e.g. for a PWM brightness control, for blinker circuits and many other purposes.

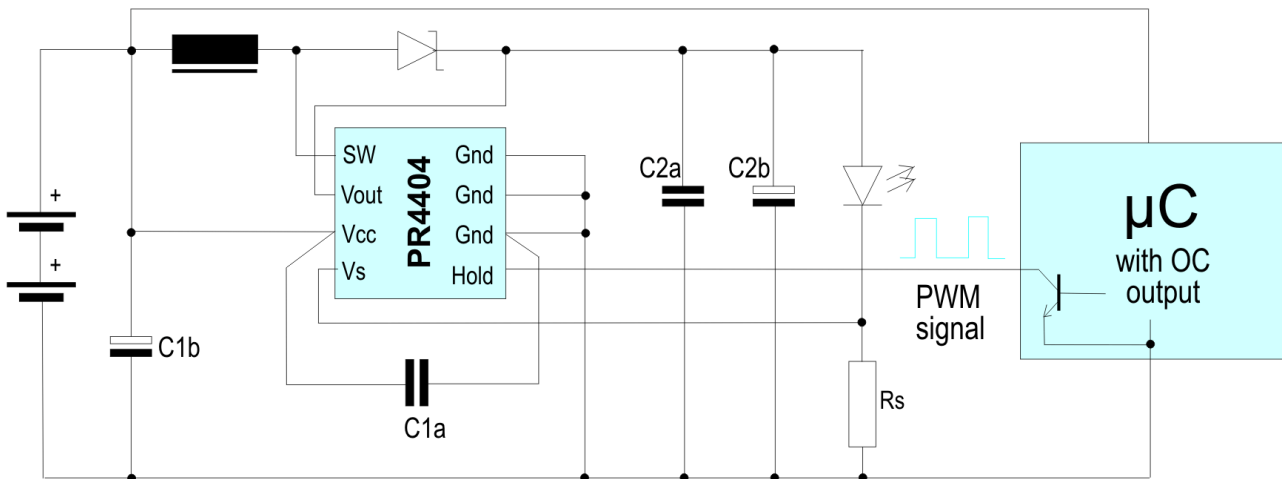

Mind that no voltage must be applied at the Hold pin, but it must only be pulled down to Gnd. Only an open collector or open drain output must be connected to Hold!

Due to the remaining quiescent current this feature is not recommended for soft-switching battery-operated lamps on and off.

## Calculation of maximum ambient temperature

Under some operating conditions, especially at high voltage transfer ratios and with low inductances, the IC can get into thermally critical states.

The following formula gives a rough estimation of the maximum temperature at which the circuit can be operated.

$P_{out}$ : output power (measured, or estimated from diagram)

$\eta$ : efficiency (measured, or estimated from diagram)

$P_{IC}$ : total power dissipation in IC

$$P_{IC} \approx \frac{(1-\eta)}{\eta} \cdot P_{out} - I_{out} \cdot V_{sense}$$

This formula assumes that the power loss occurs inside the IC and the current sense resistor, but neglects the losses in the inductor, Schottky diode, wiring and capacitors.

$T_{Amax}$ : maximum ambient temperature

$T_{Jmax}$ : maximum junction temperature (see Absolute Maximum Ratings)

$\Theta_{JA}$ : thermal resistance of package (see Electrical Characteristics)

$T_{Amax}$ : maximum ambient temperature

$$T_{Amax} = T_{Jmax} - \Theta_{JA} \cdot P_{total}$$

### Example:

According to the diagrams, with a target current of 300mA, a 1.5 $\mu$ H inductor and one LED at the output, at  $V_{CC}=2.2V$  the actual output power is 950mW, and the efficiency is 70%.

The power dissipated inside the IC can be estimated to

$$P_{IC} \approx 0.43 \cdot 0.95W - 0.3A \cdot 0.2V = 0.40W - 0.06W = 0.34W$$

Then the maximum ambient temperature is

$$T_{Amax} = 125^{\circ}C - 160K/W \cdot 0.34W = 70^{\circ}C$$

For highest reliability a permanent operation near the thermal limits should be avoided.

Actual operating limits will depend on many factors. E.g. a PCB design with good heat spreading and forced air convection may improve the situation, but a thermally sealed casing or heating from the LED or battery will make it worse.

Also the efficiency in the actual application may differ from the values given in the diagrams.

With decreasing supply voltage the voltage transfer ratio and therefore the input current rises, and the efficiency falls. As a consequence, the thermal load on the IC increases as the supply voltage falls.

Therefore battery operated circuits must be designed that while discharging the battery no critical state can occur.

## Available Package

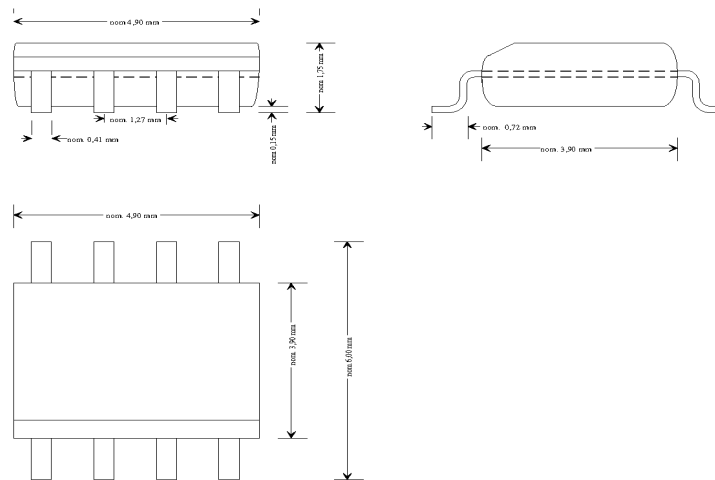

Package type: 8L SOIC (150 mils)

All parts delivered comply with RoHS. Finish is pure tin.



Pb-free



pure tin

### Disclaimer

Information provided by PREMA is believed to be accurate and correct. However, no responsibility is assumed by PREMA for its use, nor for any infringements of patents or other rights of third parties which may result from its use. PREMA reserves the right at any time without notice to change circuitry and specifications.

### Life Support Policy

PREMA Semiconductors products are not authorized for use as critical components in life support devices or systems without the express written approval of PREMA Semiconductor. As used herein:

1. Life support devices or systems are devices or systems which, (a) are intended for surgical implant into the body, or (b) support or sustain life, and whose failure to perform when properly used in accordance with instructions for use provided in the labeling, can be reasonably expected to result in a significant injury to the user.
2. A critical component is any component of a life support device or system whose failure to perform can be reasonably expected to cause the failure of the life support device or system, or to affect its safety or effectiveness.

## PREMA Semiconductor GmbH

Robert-Bosch-Str. 6

55129 Mainz Germany

Phone: +49-6131-5062-0

Fax: +49-6131-5062-220

Email: [prema@prema.com](mailto:prema@prema.com) Web site: [www.prema.com](http://www.prema.com)