

# PS2001 photomultiplier power supply for equipment manufacturers

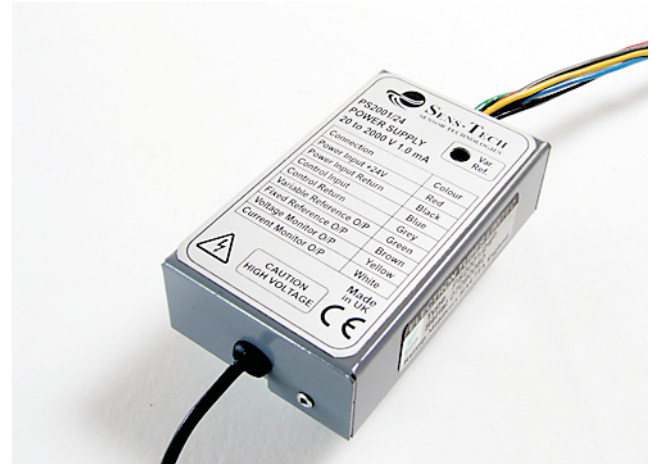

## 1 description

The PS2001P and N have been designed with the particular needs of the instrument manufacturer in mind. The modular power supply has the option of 12V or 24V input with a fully adjustable output from 0V to 2000V, via an analogue remote control or a user accessible multiturn potentiometer. A special feature is the precision 1000:1 output voltage monitor point. The PS2001 range is compatible with the PS2001 range, which it supersedes



## 2 features

- Variable output voltage to 2.0 kV
- Ultra low output ripple
- Precision output monitor point
- 24V or 12V input versions
- Precision reference output

## 3 specification

### electrical

input voltage range	
24V option	+22V to +28V dc
12V option	+11V to +15V dc
input current at full load	
24V option	250 mA
12V option	400 mA
output voltage	<20 to 2000V dc
output current	0 to 1mA 20
polarity	positive or negative, factory set
load regulation	20 ppm no load to full load
line regulation	20 ppm/V
HF ripple	1mV p-p typical
LF noise	4mV p-p typical
temperature coefficient	50 ppm °C <sup>-1</sup>

### stability

short term	<15 ppm
in any 15 minute period after 1 hour warm-up	
long term	<50 ppm
in any 8 hour period, after 1 hour warm-up	

### temperature

operating range	0 to +50 °C
storage range	-5 to +70 °C

### protection

the unit is protected against

- input polarity reversal
- output overload
- output flashover
- output short circuit

### reference

temperature coefficient	50 ppm/°C
-------------------------	-----------

24V option	
fixed	+10V ± 0.05%, 3mA max.
adjustable	0 to +5V, multiturn potentiometer

12V option	
fixed	+5V ± 0.05%, 3mA max.
adjustable	0 to +5V, multiturn potentiometer

### voltage and current monitor

voltage monitor	1000 : 1
24V option current monitor	10V for 100%
12V option current monitor	5V for 100%

accuracy ±1%, source impedance 10k

### voltage control

24V option	(blue) 10V for 100%
12V option	(orange) 10V for 100%
12V option	(blue) 5V for 100%
input impedance	1M
output slew rate	50V/ms typical

## 4 connections

### flying leads

input	red	power input +ve
	black	power input return
	grey	signal 0V
	brown	fixed reference
	green	adjustable reference
	pink	voltage monitor
	white	current monitor
24V option	blue	control input 0V to 10V
12V option	blue	control input to 5V
12V option	orange	control input to 10V

(all leads 0.5 metres long)

### HV output

unterminated coaxial cable RG174 (0.5 metres long)

## 5 outline drawing (mm)

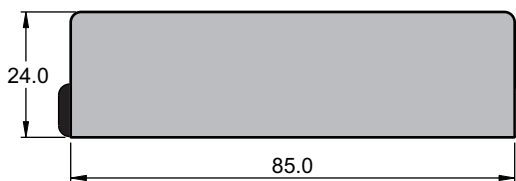

Cables not shown in this view

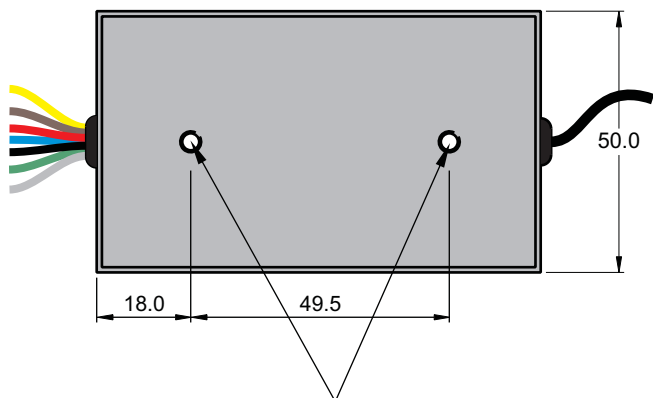

M4 threaded mounting points

View of underside

weight

150g

## 6 ordering information

Item	Order code
PS2001, 24V, positive output	PS2001/24P
PS2001, 24V, negative output	PS2001/24N
PS2001, 12V, positive output	PS2001/12P
PS2001, 12V, negative output	PS2001/12N

## 7 application note

The output voltage is controlled by the application of an external voltage using one of the following three methods.

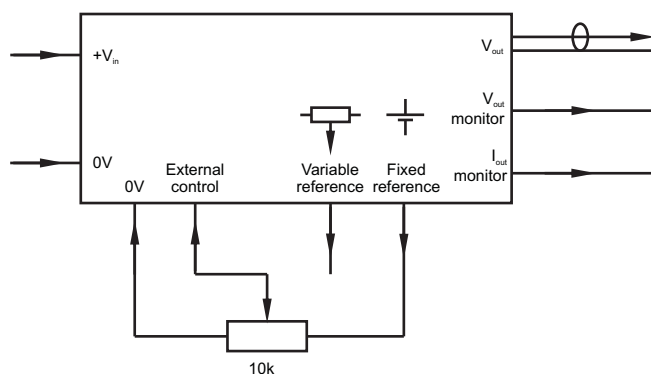
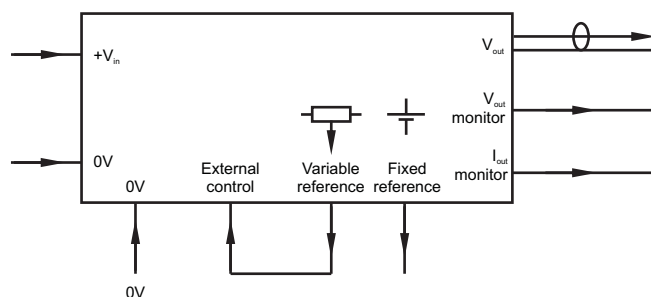
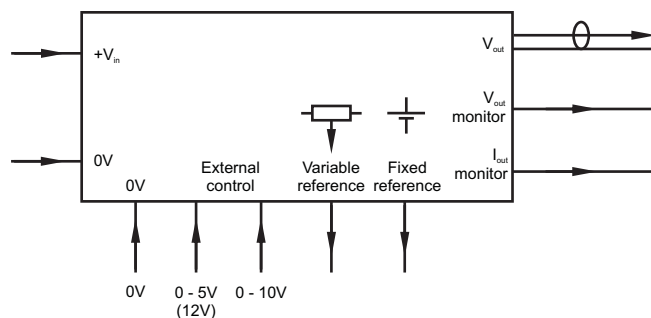

It is important to connect any voltage monitoring instrumentation between the pink and grey leads. The use of any other return can result in error.

## 8 warning

High voltages generated by these products present an electrical shock hazard and appropriate precautions must be taken. They must be installed by qualified personnel and operated within the specified ratings.

Do not operate outside the ratings limit. This may result in loss of performance or permanent damage to the PS2001.