

PS21961-4S

TRANSFER-MOLD TYPE
INSULATED TYPE

PS21961-4S



INTEGRATED POWER FUNCTIONS

600V/3A low-loss RC-IGBT inverter bridge with N-side three phase output DC-to-AC power conversion.
Open emitter type.

INTEGRATED DRIVE, PROTECTION AND SYSTEM CONTROL FUNCTIONS

- For upper-leg IGBTs : Drive circuit, High voltage high-speed level shifting, Control supply under-voltage (UV) protection.
- For lower-leg IGBTs : Drive circuit, Control supply under-voltage protection (UV), Short circuit protection (SC).
- Fault signaling : Corresponding to an SC fault (Lower-leg IGBT) or a UV fault (Lower-side supply).
- Input interface : 3V, 5V line (High Active).
- UL Approved : Yellow Card No. E80276

APPLICATION

AC100V~200V inverter drive for small power motor control.

Fig. 1 PACKAGE OUTLINES

Dimensions in mm

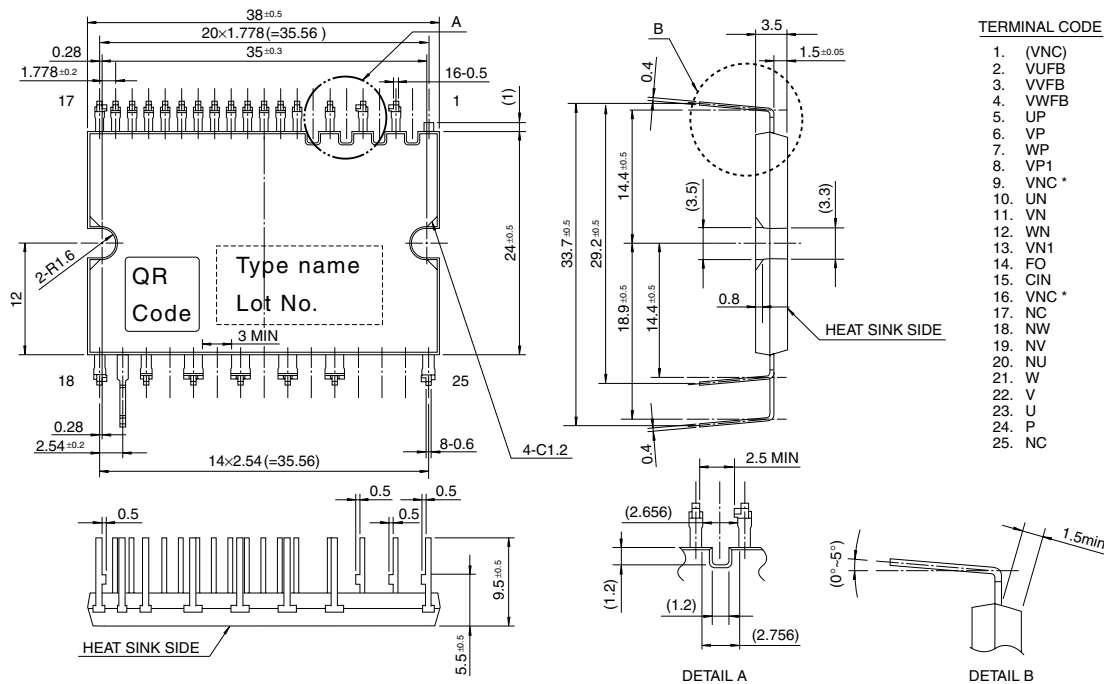

*) Two VNC terminals (9 & 16 pin) are connected inside DIP-IPM, please connect either one to the 15V power supply GND outside and leave another one open.

PS21961-4S

TRANSFER-MOLD TYPE
INSULATED TYPE

MAXIMUM RATINGS ($T_j = 25^\circ\text{C}$, unless otherwise noted)

INVERTER PART

Symbol	Parameter	Condition	Ratings	Unit
V _{CC}	Supply voltage	Applied between P-NU, NV, NW	450	V
V _{CC(surge)}	Supply voltage (surge)	Applied between P-NU, NV, NW	500	V
V _{CES}	Collector-emitter voltage		600	V
±I _C	Each IGBT collector current	T _C = 25°C	3	A
±I _{CP}	Each IGBT collector current (peak)	T _C = 25°C, less than 1ms	6	A
P _C	Collector dissipation	T _C = 25°C, per 1 chip	21.3	W
T _j	Junction temperature	(Note 1)	-20~+125	°C

Note 1 : The maximum junction temperature rating of the power chips integrated within the DIP-IPM is 150°C (@ T_C ≤ 100°C). However, to ensure safe operation of the DIP-IPM, the average junction temperature should be limited to T_{j(ave)} ≤ 125°C (@ T_C ≤ 100°C).

CONTROL (PROTECTION) PART

Symbol	Parameter	Condition	Ratings	Unit
V _D	Control supply voltage	Applied between VP1-VNC, VN1-VNC	20	V
V _{DB}	Control supply voltage	Applied between VUFB-U, VVFB-V, VWFB-W	20	V
V _{IN}	Input voltage	Applied between UP, VP, WP, UN, VN, WN-VNC	-0.5~V _D +0.5	V
V _{FO}	Fault output supply voltage	Applied between FO-VNC	-0.5~V _D +0.5	V
I _{FO}	Fault output current	Sink current at FO terminal	1	mA
V _{SC}	Current sensing input voltage	Applied between CIN-VNC	-0.5~V _D +0.5	V

TOTAL SYSTEM

Symbol	Parameter	Condition	Ratings	Unit
V _{CC(PROT)}	Self protection supply voltage limit (short circuit protection capability)	V _D = 13.5~16.5V, Inverter part T _j = 125°C, non-repetitive, less than 2μs	400	V
T _C	Module case operation temperature	(Note 2)	-20~+100	°C
T _{stg}	Storage temperature		-40~+125	°C
V _{iso}	Isolation voltage	60Hz, Sinusoidal, 1 minute, Between pins and heat-sink plate	1500	V _{rms}

Note 2: T_C measurement point

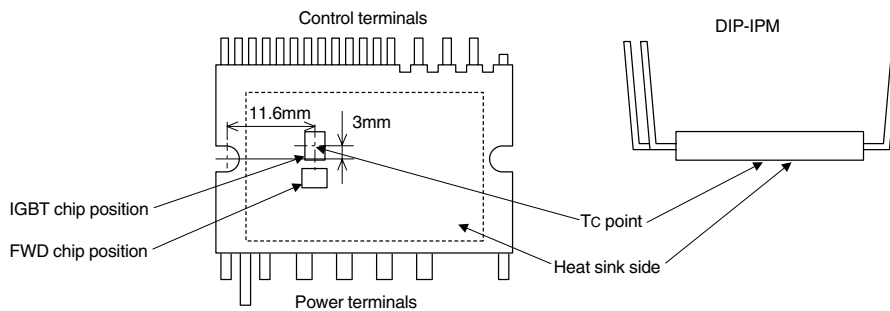

PS21961-4S

TRANSFER-MOLD TYPE
INSULATED TYPE

THERMAL RESISTANCE

Symbol	Parameter	Condition	Limits			Unit
			Min.	Typ.	Max.	
$R_{th(j-c)Q}$	Junction to case thermal resistance (Note 3)	Inverter RC-IGBT part (per 1/6 module)	—	—	4.7	°C/W

Note 3 : Grease with good thermal conductivity should be applied evenly with about +100 μ m~+200 μ m on the contacting surface of DIP-IPM and heat-sink.

The contacting thermal resistance between DIP-IPM case and heat sink ($R_{th(c-f)}$) is determined by the thickness and the thermal conductivity of the applied grease. For reference, $R_{th(c-f)}$ (per 1/6 module) is about 0.3°C/W when the grease thickness is 20 μ m and the thermal conductivity is 1.0W/m·k.

ELECTRICAL CHARACTERISTICS ($T_j = 25^\circ\text{C}$, unless otherwise noted)

INVERTER PART

Symbol	Parameter	Condition	Limits			Unit
			Min.	Typ.	Max.	
$V_{CE(sat)}$	Collector-emitter saturation voltage	$V_D = V_{DB} = 15\text{V}$ $V_{IN} = 5\text{V}$	—	1.70	2.20	V
		$I_C = 3\text{A}, T_j = 25^\circ\text{C}$ $I_C = 3\text{A}, T_j = 125^\circ\text{C}$	—	1.80	2.30	
V_{EC}	FWD forward voltage	$T_j = 25^\circ\text{C}, -I_C = 3\text{A}, V_{IN} = 0\text{V}$	—	1.50	2.00	V
t_{on}	Switching times	$V_{CC} = 300\text{V}, V_D = V_{DB} = 15\text{V}$ $I_C = 3\text{A}, T_j = 125^\circ\text{C}, V_{IN} = 0 \leftrightarrow 5\text{V}$ Inductive load (upper-lower arm)	0.50	0.95	1.50	μs
t_{tr}			—	0.30	—	μs
$t_{c(on)}$			—	0.35	0.60	μs
t_{off}			—	1.40	2.00	μs
$t_{c(off)}$			—	0.50	0.80	μs
I_{CES}			Collector-emitter cut-off current	$V_{CE} = V_{CES}$	—	—
		$T_j = 25^\circ\text{C}$ $T_j = 125^\circ\text{C}$	—	—	10	

CONTROL (PROTECTION) PART

Symbol	Parameter	Condition	Limits			Unit	
			Min.	Typ.	Max.		
I_D	Circuit current	$V_D = V_{DB} = 15\text{V}$ $V_{IN} = 5\text{V}$	Total of V_{P1-VNC}, V_{N1-VNC}	—	—	2.80	mA
			$V_{UFB-U}, V_{VFB-V}, V_{WFB-W}$	—	—	0.55	
		$V_D = V_{DB} = 15\text{V}$ $V_{IN} = 0\text{V}$	Total of V_{P1-VNC}, V_{N1-VNC}	—	—	2.80	
			$V_{UFB-U}, V_{VFB-V}, V_{WFB-W}$	—	—	0.55	
V_{FOH}	Fault output voltage	$V_{SC} = 0\text{V}, F_O$ terminal pull-up to 5V by 10k Ω	4.9	—	—	V	
V_{FOL}		$V_{SC} = 1\text{V}, I_{FO} = 1\text{mA}$	—	—	0.95	V	
$V_{SC(ref)}$	Short circuit trip level	$T_j = 25^\circ\text{C}, V_D = 15\text{V}$ (Note 4)	0.43	0.48	0.53	V	
I_{IN}	Input current	$V_{IN} = 5\text{V}$	0.70	1.00	1.50	mA	
UV_{DBt}	Control supply under-voltage protection	$T_j \leq 125^\circ\text{C}$	Trip level	10.0	—	12.0	V
UV_{DBr}			Reset level	10.5	—	12.5	V
UV_{Dt}			Trip level	10.3	—	12.5	V
UV_{Dr}			Reset level	10.8	—	13.0	V
t_{FO}	Fault output pulse width	(Note 5)	20	—	—	μs	
$V_{th(on)}$	ON threshold voltage	Applied between UP, VP, WP, UN, VN, WN-VNC	—	2.1	2.6	V	
$V_{th(off)}$	OFF threshold voltage		0.8	1.3	—	V	
$V_{th(hys)}$	ON/OFF threshold hysteresis voltage		0.35	0.65	—	V	

Note 4 : Short circuit protection is functioning only for the lower-arms. Please select the external shunt resistance such that the SC trip-level is less than 1.7 times of the current rating.

5 : Fault signal is asserted corresponding to a short circuit or lower side control supply under-voltage failure.

PS21961-4S

TRANSFER-MOLD TYPE
INSULATED TYPE

MECHANICAL CHARACTERISTICS AND RATINGS

Parameter	Condition		Limits			Unit
			Min.	Typ.	Max.	
Mounting torque	Mounting screw : M3 (Note 6)	Recommended : 0.69 N·m	0.59	—	0.78	N·m
Weight			—	10	—	g
Heat-sink flatness	(Note 7)		-50	—	100	μm

Note 6 : Plain washers (ISO 7089~7094) are recommended.

Note 7 : Flatness measurement position

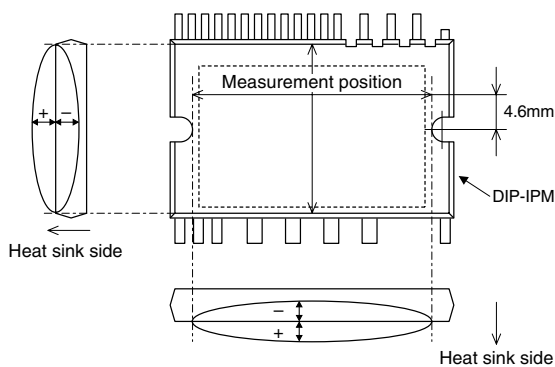

RECOMMENDED OPERATION CONDITIONS

Symbol	Parameter	Condition	Limits			Unit	
			Min.	Typ.	Max.		
VCC	Supply voltage	Applied between P-NU, NV, NW	0	300	400	V	
VD	Control supply voltage	Applied between VP1-VNC, VN1-VNC	13.5	15.0	16.5	V	
VDB	Control supply voltage	Applied between VUFB-U, VVFB-V, VWFB-W	13.0	15.0	18.5	V	
ΔVD, ΔVDB	Control supply variation		-1	—	1	V/μs	
t _{dead}	Arm shoot-through blocking time	For each input signal, T _c ≤ 100°C	1.5	—	—	μs	
f _{PWM}	PWM input frequency	T _c ≤ 100°C, T _j ≤ 125°C	—	—	20	kHz	
I _O	Allowable r.m.s. current	V _{CC} = 300V, V _D = V _{DB} = 15V, P.F = 0.8, sinusoidal PWM, T _j ≤ 125°C, T _c ≤ 100°C (Note 8)	f _{PWM} = 5kHz	—	—	2.0	Arms
			f _{PWM} = 15kHz	—	—	1.5	
P _{WIN(on)}	Allowable minimum input pulse width	(Note 9)		0.5	—	—	μs
P _{WIN(off)}				0.5	—	—	
V _{NC}	V _{NC} variation	Between V _{NC} -NU, NV, NW (including surge)	-5.0	—	5.0	V	

Note 8 : The allowable r.m.s. current value depends on the actual application conditions.

9 : IPM might not make response if the input signal pulse width is less than the recommended minimum value.

PS21961-4S

TRANSFER-MOLD TYPE
INSULATED TYPE

Fig. 2 THE DIP-IPM INTERNAL CIRCUIT

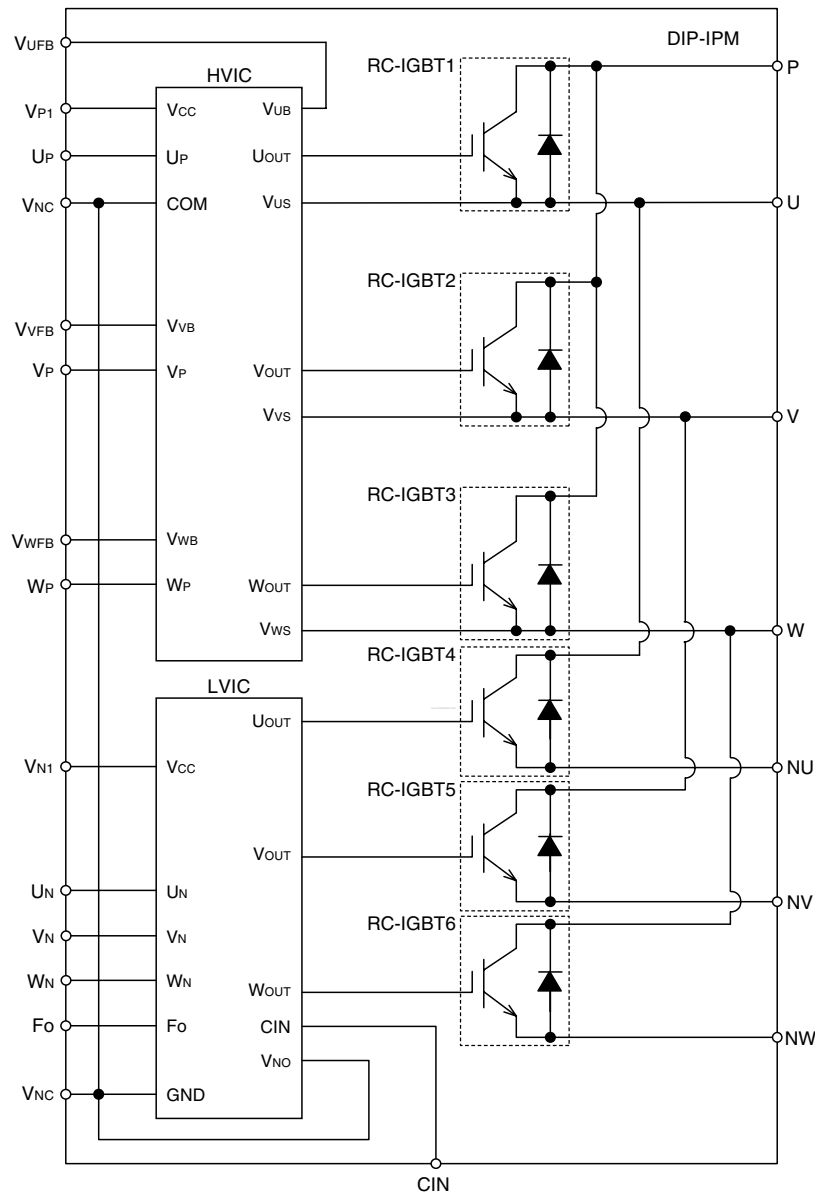
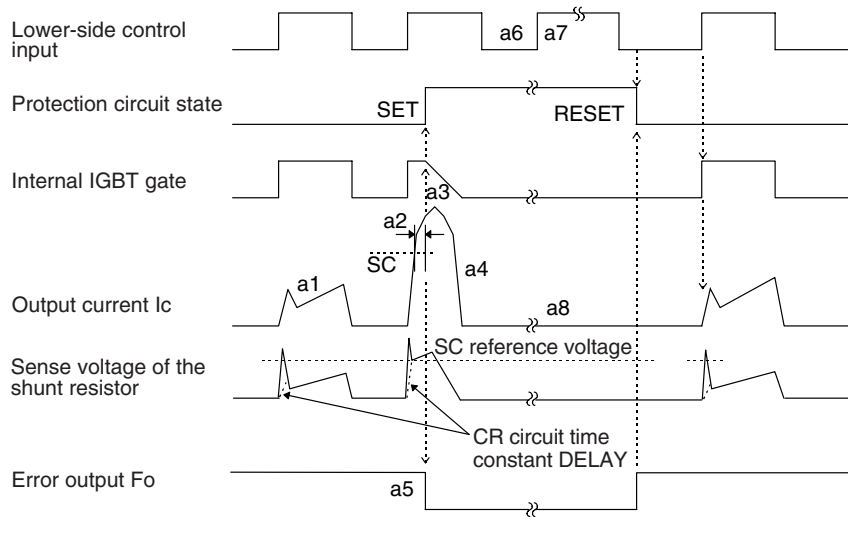

Fig. 3 TIMING CHART OF THE DIP-IPM PROTECTIVE FUNCTIONS

[A] Short-Circuit Protection (Lower-side only with the external shunt resistor and CR filter)

- a1. Normal operation : IGBT ON and carrying current.
- a2. Short circuit detection (SC trigger).
- a3. IGBT gate hard interruption.
- a4. IGBT turns OFF.
- a5. FO outputs ($t_{FO(min)} = 20\mu s$).
- a6. Input "L" : IGBT OFF.
- a7. Input "H" : IGBT ON.
- a8. IGBT OFF in spite of input "H".



[B] Under-Voltage Protection (Lower-side, UVd)

- b1. Control supply voltage rising : After the voltage level reaches UV_{Dr} , the circuits start to operate when next input is applied.
- b2. Normal operation : IGBT ON and carrying current.
- b3. Under voltage trip (UV_{Dt}).
- b4. IGBT OFF in spite of control input condition.
- b5. FO outputs ($t_{FO} \geq 20\mu s$ and Fo outputs continuously during UV period).
- b6. Under voltage reset (UV_{Dr}).
- b7. Normal operation : IGBT ON and carrying current.

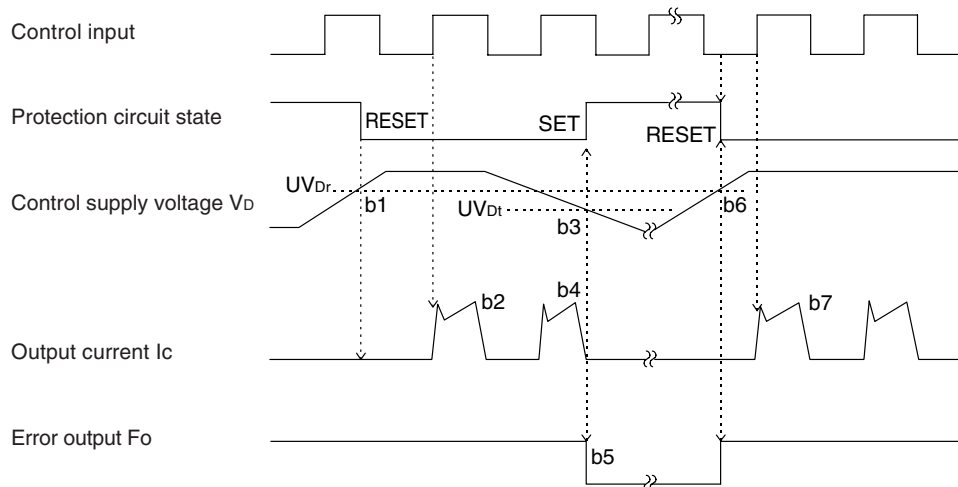

PS21961-4S

TRANSFER-MOLD TYPE
INSULATED TYPE

[C] Under-Voltage Protection (Upper-side, UVDB)

- c1. Control supply voltage rising : After the voltage level reaches UVDBr, the circuits start to operate when next input is applied.
- c2. Normal operation : IGBT ON and carrying current.
- c3. Under voltage trip (UVDBt).
- c4. IGBT OFF in spite of control input signal level, but there is no Fo signal outputs.
- c5. Under voltage reset (UVDBr).
- c6. Normal operation : IGBT ON and carrying current.

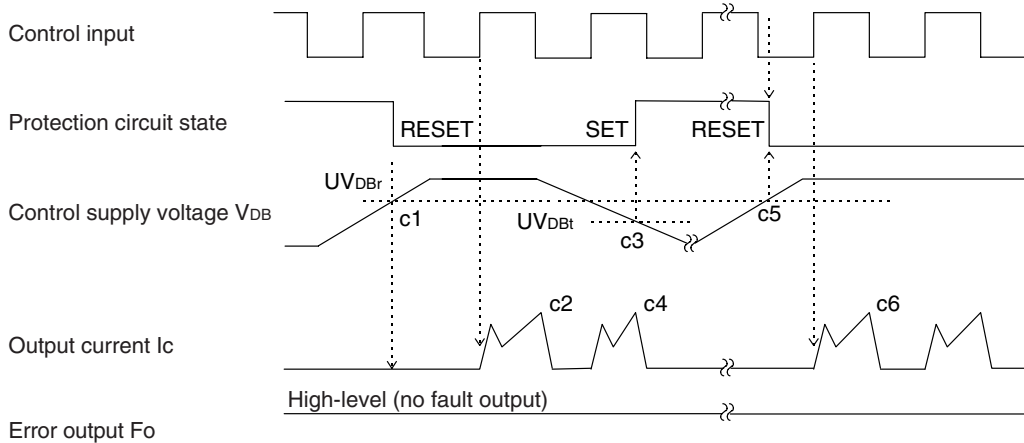
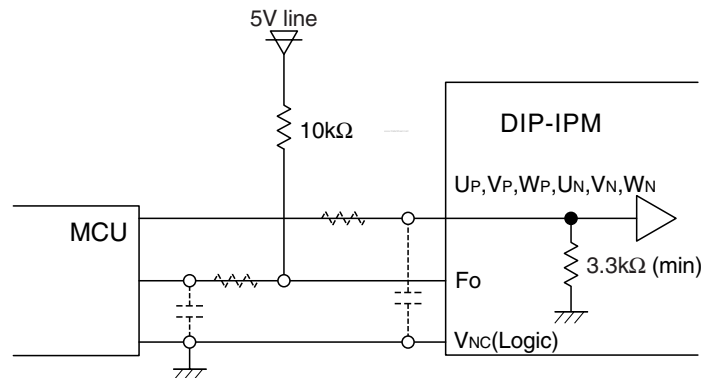

Fig. 4 RECOMMENDED MCU I/O INTERFACE CIRCUIT



Note : The setting of RC coupling at each input (parts shown dotted) depends on the PWM control scheme and the wiring impedance of the printed circuit board.
The DIP-IPM input section integrates a 3.3kΩ (min) pull-down resistor. Therefore, when using an external filtering resistor, pay attention to the turn-on threshold voltage.

Fig. 5 WIRING CONNECTION OF SHUNT RESISTOR

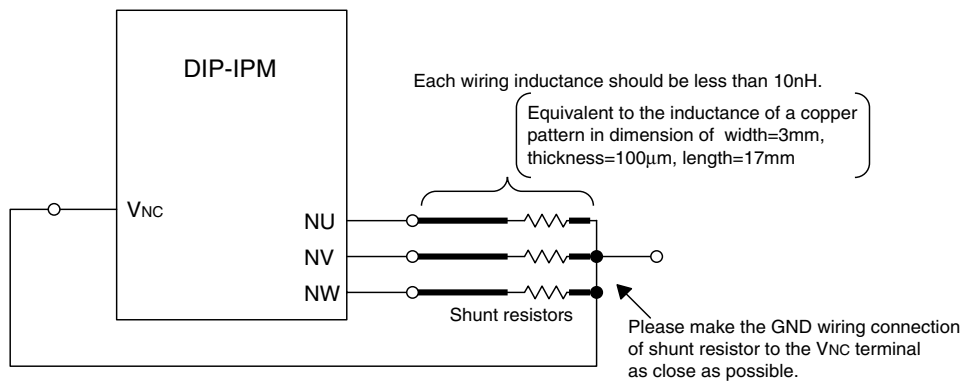
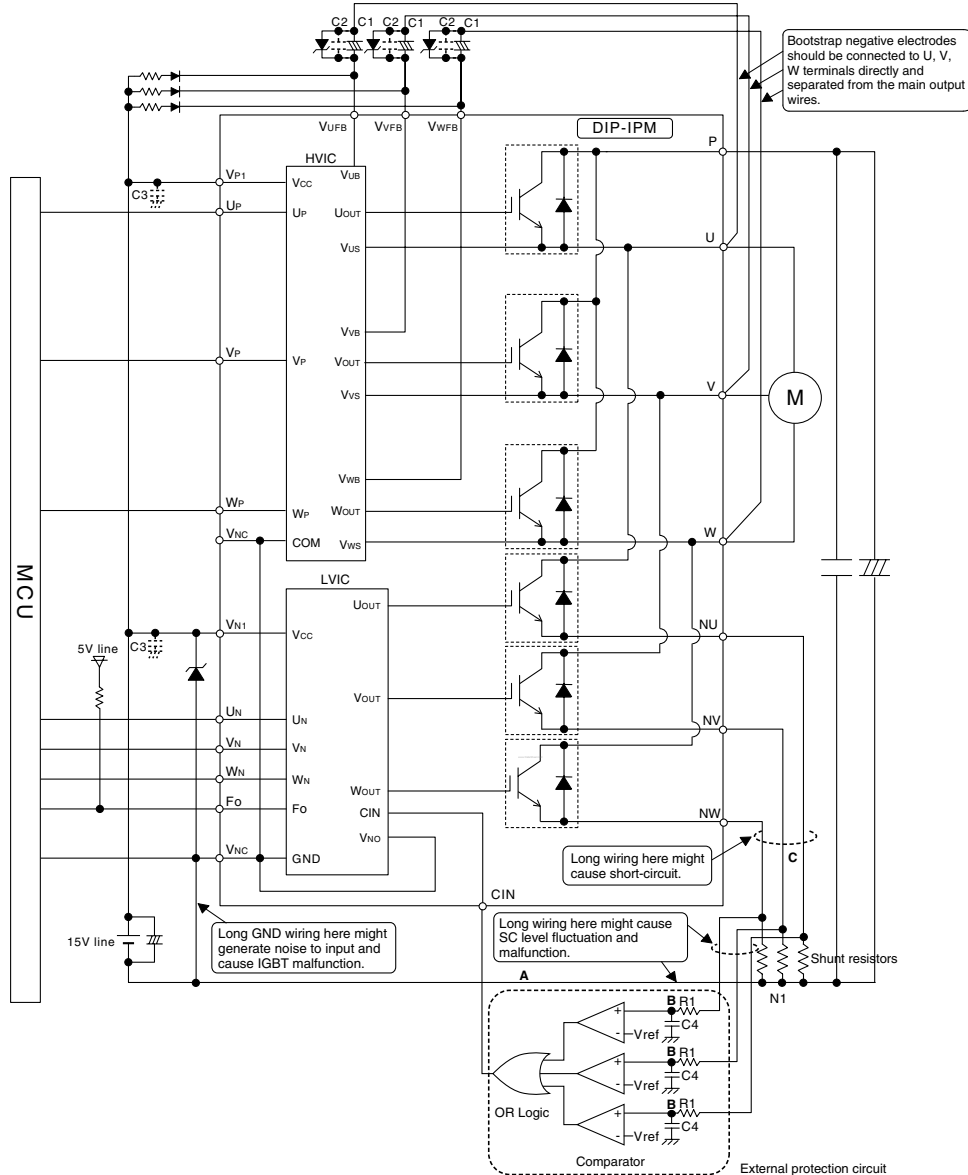

Fig. 6 AN EXAMPLE OF TYPICAL DIP-IPM APPLICATION CIRCUIT

C1: Electrolytic capacitor with good temperature characteristics C2,C3: 0.22~2μF R-category ceramic capacitor for noise filtering



- Note 1** : Input drive is High-Active type. There is a 3.3kΩ(min.) pull-down resistor integrated in the IC input circuit. To prevent malfunction, the wiring of each input should be as short as possible. When using RC coupling circuit, make sure the input signal level meet the turn-on and turn-off threshold voltage.
- 2** : Thanks to HVIC inside the module, direct coupling to MCU without any opto-coupler or transformer isolation is possible.
- 3** : Fo output is open drain type. It should be pulled up to the positive side of a 5V power supply by a resistor of about 10kΩ.
- 4** : To prevent erroneous protection, the wiring of A, B, C should be as short as possible.
- 5** : The time constant R1C4 of the protection circuit should be selected in the range of 1.5~2μs. SC interrupting time might vary with the wiring pattern. Tight tolerance, temp-compensated type is recommended for R1, C4.
- 6** : All capacitors should be mounted as close to the terminals of the DIP-IPM as possible. (C1: good temperature, frequency characteristic electrolytic type, and C2, C3: good temperature, frequency and DC bias characteristic ceramic type are recommended.)
- 7** : To prevent surge destruction, the wiring between the smoothing capacitor and the P, N1 terminals should be as short as possible. Generally a 0.1~0.22μF snubber between the P-N1 terminals is recommended.
- 8** : Two VNC terminals (9 & 16 pin) are connected inside DIP-IPM, please connect either one to the 15V power supply GND outside and leave another one open.
- 9** : It is recommended to insert a Zener diode (24V/1W) between each pair of control supply terminals to prevent surge destruction.
- 10** : If control GND is connected to power GND by broad pattern, it may cause malfunction by power GND fluctuation. It is recommended to connect control GND and power GND at only a point.
- 11** : The reference voltage Vref of comparator should be set up the same rating of short circuit trip level (Vsc(ref): min.0.43V to max.0.53V).
- 12** : OR logic output high level should exceed the maximum short circuit trip level (Vsc(ref): max.0.53V).