

PS21962-S

TRANSFER-MOLD TYPE
INSULATED TYPE

PS21962-S



INTEGRATED POWER FUNCTIONS

600V/5A low-loss 5th generation IGBT inverter bridge for three phase DC-to-AC power conversion.
Open emitter type.

INTEGRATED DRIVE, PROTECTION AND SYSTEM CONTROL FUNCTIONS

- For upper-leg IGBTs : Drive circuit, High voltage isolated high-speed level shifting, Control supply under-voltage (UV) protection.
- For lower-leg IGBTs : Drive circuit, Control supply under-voltage protection (UV), Short circuit protection (SC).
- Fault signaling : Corresponding to an SC fault (Lower-leg IGBT) or a UV fault (Lower-side supply).
- Input interface : 3V, 5V line (High Active).

APPLICATION

AC100V~200V inverter drive for small power motor control.

Fig. 1 PACKAGE OUTLINES

Dimensions in mm

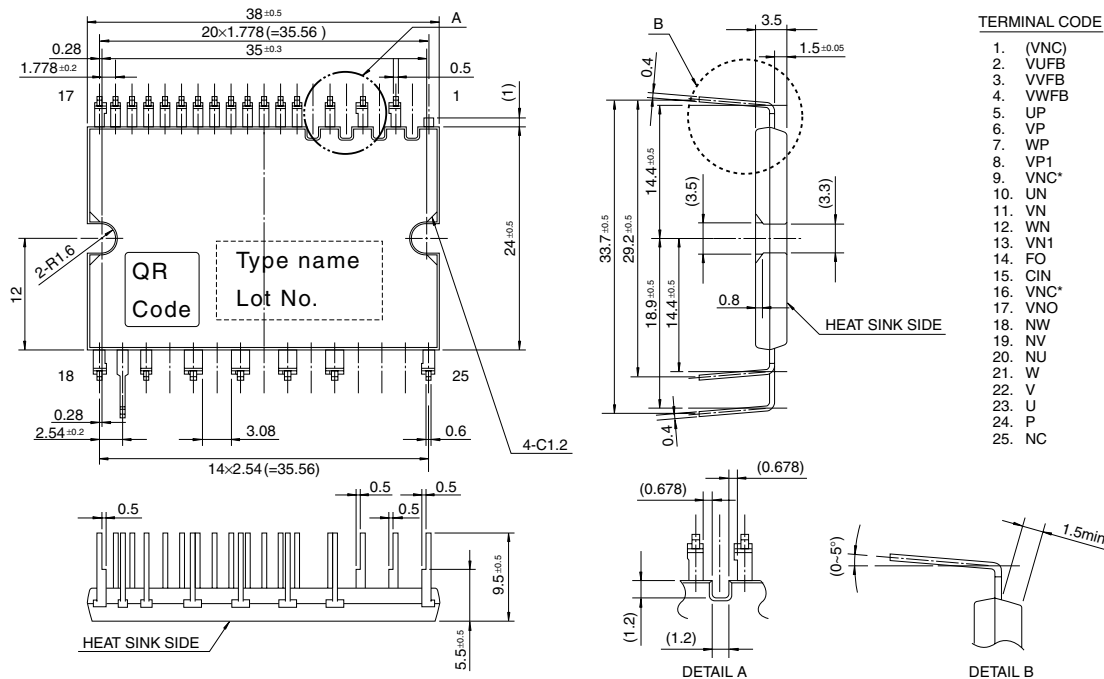

*) Two Vnc terminals (9 & 16 pin) are connected inside DIP-IPM, please connect either one to the 15V power supply GND outside and leave another one open.

PS21962-S

TRANSFER-MOLD TYPE
INSULATED TYPE

MAXIMUM RATINGS ($T_j = 25^\circ\text{C}$, unless otherwise noted)

INVERTER PART

Symbol	Parameter	Condition	Ratings	Unit
VCC	Supply voltage	Applied between P-NU, NV, NW	450	V
VCC(surge)	Supply voltage (surge)	Applied between P-NU, NV, NW	500	V
VCEs	Collector-emitter voltage		600	V
$\pm I_C$	Each IGBT collector current	$T_c = 25^\circ\text{C}$	5	A
$\pm I_{CP}$	Each IGBT collector current (peak)	$T_c = 25^\circ\text{C}$, less than 1ms	10	A
PC	Collector dissipation	$T_c = 25^\circ\text{C}$, per 1 chip	21.3	W
T_j	Junction temperature	(Note 1)	-20~+125	$^\circ\text{C}$

Note 1 : The maximum junction temperature rating of the power chips integrated within the DIP-IPM is 150°C (@ $T_c \leq 100^\circ\text{C}$). However, to ensure safe operation of the DIP-IPM, the average junction temperature should be limited to $T_{j(\text{ave})} \leq 125^\circ\text{C}$ (@ $T_c \leq 100^\circ\text{C}$).

CONTROL (PROTECTION) PART

Symbol	Parameter	Condition	Ratings	Unit
V _D	Control supply voltage	Applied between VP1-VNC, VN1-VNC	20	V
V _{DB}	Control supply voltage	Applied between VUFB-U, VVFB-V, VWFB-W	20	V
V _{IN}	Input voltage	Applied between UP, VP, WP, UN, VN, WN-VNC	-0.5~V _D +0.5	V
V _{FO}	Fault output supply voltage	Applied between FO-VNC	-0.5~V _D +0.5	V
I _{FO}	Fault output current	Sink current at FO terminal	1	mA
V _{SC}	Current sensing input voltage	Applied between CIN-VNC	-0.5~V _D +0.5	V

TOTAL SYSTEM

Symbol	Parameter	Condition	Ratings	Unit
V _{CC(Prot)}	Self protection supply voltage limit (short circuit protection capability)	V _D = 13.5~16.5V, Inverter part $T_j = 125^\circ\text{C}$, non-repetitive, less than 2 μs	400	V
T _C	Module case operation temperature	(Note 2)	-20~+100	$^\circ\text{C}$
T _{stg}	Storage temperature		-40~+125	$^\circ\text{C}$
V _{iso}	Isolation voltage	60Hz, Sinusoidal, 1 minute, All connected pins to heat-sink plate	1500	V _{rms}

Note 2: T_C measurement point

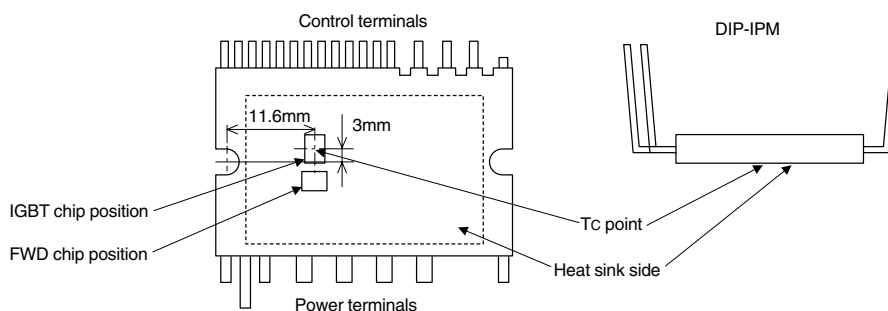

PS21962-S

**TRANSFER-MOLD TYPE
INSULATED TYPE**

THERMAL RESISTANCE

Symbol	Parameter	Condition	Limits			Unit
			Min.	Typ.	Max.	
$R_{th(j-c)Q}$	Junction to case thermal resistance (Note 3)	Inverter IGBT part (per 1/6 module)	—	—	4.7	°C/W
$R_{th(j-c)F}$		Inverter FWD part (per 1/6 module)	—	—	5.4	°C/W

Note 3 : Grease with good thermal conductivity should be applied evenly with about +100 μ m~+200 μ m on the contacting surface of DIP-IPM and heat-sink.

The contacting thermal resistance between DIP-IPM case and heat sink ($R_{th(c-f)}$) is determined by the thickness and the thermal conductivity of the applied grease. For reference, $R_{th(c-f)}$ (per 1/6 module) is about 0.3°C/W when the grease thickness is 20 μ m and the thermal conductivity is 1.0W/m.k.

ELECTRICAL CHARACTERISTICS ($T_j = 25^\circ\text{C}$, unless otherwise noted)

INVERTER PART

Symbol	Parameter	Condition	Limits			Unit
			Min.	Typ.	Max.	
$V_{CE(sat)}$	Collector-emitter saturation voltage	$V_D = V_{DB} = 15\text{V}$ $V_{IN} = 5\text{V}$	—	1.70	2.20	V
		$I_C = 5\text{A}, T_j = 25^\circ\text{C}$ $I_C = 5\text{A}, T_j = 125^\circ\text{C}$	—	1.80	2.30	
V_{EC}	FWD forward voltage	$T_j = 25^\circ\text{C}, -I_C = 5\text{A}, V_{IN} = 0\text{V}$	—	1.70	2.20	V
t_{on}	Switching times	$V_{CC} = 300\text{V}, V_D = V_{DB} = 15\text{V}$ $I_C = 5\text{A}, T_j = 125^\circ\text{C}, V_{IN} = 0 \leftrightarrow 5\text{V}$ Inductive load (upper-lower arm)	0.50	1.00	1.60	μs
t_{tr}			—	0.30	—	μs
$t_{c(on)}$			—	0.30	0.50	μs
t_{off}			—	1.40	2.00	μs
$t_{c(off)}$			—	0.50	0.80	μs
I_{CES}			Collector-emitter cut-off current	$V_{CE} = V_{CES}$	—	—
	$T_j = 25^\circ\text{C}$ $T_j = 125^\circ\text{C}$	—		—	10	

CONTROL (PROTECTION) PART

Symbol	Parameter	Condition	Limits			Unit	
			Min.	Typ.	Max.		
I_D	Circuit current	$V_D = V_{DB} = 15\text{V}$ $V_{IN} = 5\text{V}$	Total of VP1-VNC, VN1-VNC	—	—	2.80	mA
			VUFB-U, VVFB-V, VWFB-W	—	—	0.55	
		$V_D = V_{DB} = 15\text{V}$ $V_{IN} = 0\text{V}$	Total of VP1-VNC, VN1-VNC	—	—	2.80	
			VUFB-U, VVFB-V, VWFB-W	—	—	0.55	
V_{FOH}	Fault output voltage	$V_{SC} = 0\text{V}$, FO terminal pull-up to 5V by 10k Ω	4.9	—	—	V	
V_{FOL}		$V_{SC} = 1\text{V}, I_{FO} = 1\text{mA}$	—	—	0.95	V	
$V_{SC(ref)}$	Short circuit trip level	$T_j = 25^\circ\text{C}, V_D = 15\text{V}$ (Note 4)	0.43	0.48	0.53	V	
I_{IN}	Input current	$V_{IN} = 5\text{V}$	0.70	1.00	1.50	mA	
UV_{DBt}	Control supply under-voltage protection	$T_j \leq 125^\circ\text{C}$	Trip level	10.0	—	12.0	V
UV_{DBr}			Reset level	10.5	—	12.5	V
UV_{Dt}			Trip level	10.3	—	12.5	V
UV_{Dr}			Reset level	10.8	—	13.0	V
t_{FO}	Fault output pulse width	(Note 5)	20	—	—	μs	
$V_{th(on)}$	ON threshold voltage	Applied between UP, VP, WP, UN, VN, WN-VNC	—	2.1	2.6	V	
$V_{th(off)}$	OFF threshold voltage		0.8	1.3	—	V	
$V_{th(hys)}$	ON/OFF threshold hysteresis voltage		0.35	0.65	—	V	

Note 4 : Short circuit protection is functioning only for the lower-arms. Please select the external shunt resistance such that the SC trip-level is less than 1.7 times of the current rating.

5 : Fault signal is asserted corresponding to a short circuit or lower side control supply under-voltage failure.

PS21962-S

TRANSFER-MOLD TYPE
INSULATED TYPE

MECHANICAL CHARACTERISTICS AND RATINGS

Parameter	Condition		Limits			Unit
			Min.	Typ.	Max.	
Mounting torque	Mounting screw : M3 (Note 6)	Recommended : 0.69 N·m	0.59	—	0.78	N·m
Weight			—	10	—	g
Heat-sink flatness	(Note 7)		-50	—	100	μm

Note 6 : Plain washers (ISO 7089~7094) are recommended.

Note 7 : Flatness measurement position

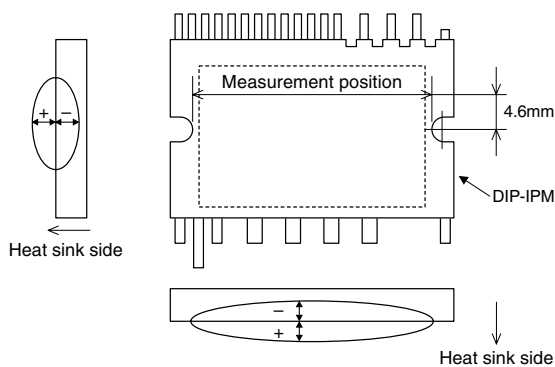

RECOMMENDED OPERATION CONDITIONS

Symbol	Parameter	Condition	Recommended value			Unit	
			Min.	Typ.	Max.		
VCC	Supply voltage	Applied between P-NU, NV, NW	0	300	400	V	
VD	Control supply voltage	Applied between VP1-VNC, VN1-VNC	13.5	15.0	16.5	V	
VDB	Control supply voltage	Applied between VUFB-U, VVFB-V, VWFB-W	13.0	15.0	18.5	V	
ΔVD, ΔVDB	Control supply variation		-1	—	1	V/μs	
t _{dead}	Arm shoot-through blocking time	For each input signal, T _c ≤ 100°C	1.5	—	—	μs	
I _o	Allowable r.m.s. current	V _{CC} = 300V, V _D = V _{DB} = 15V, P.F = 0.8, sinusoidal output, T _j ≤ 125°C, T _c ≤ 100°C (Note 8)	f _{PWM} = 5kHz	—	—	2.5	Arms
			f _{PWM} = 15kHz	—	—	1.5	
PWIN(on)	Allowable minimum input pulse width	(Note 9)		0.5	—	—	μs
PWIN(off)				0.5	—	—	
VNC	VNC variation	Between VNC-NU, NV, NW (including surge)	-5.0	—	5.0	V	

Note 8 : The allowable r.m.s. current value depends on the actual application conditions.

9 : IPM might not make response if the input signal pulse width is less than the recommended minimum value.

PS21962-S

TRANSFER-MOLD TYPE
INSULATED TYPE

Fig. 2 THE DIP-IPM INTERNAL CIRCUIT

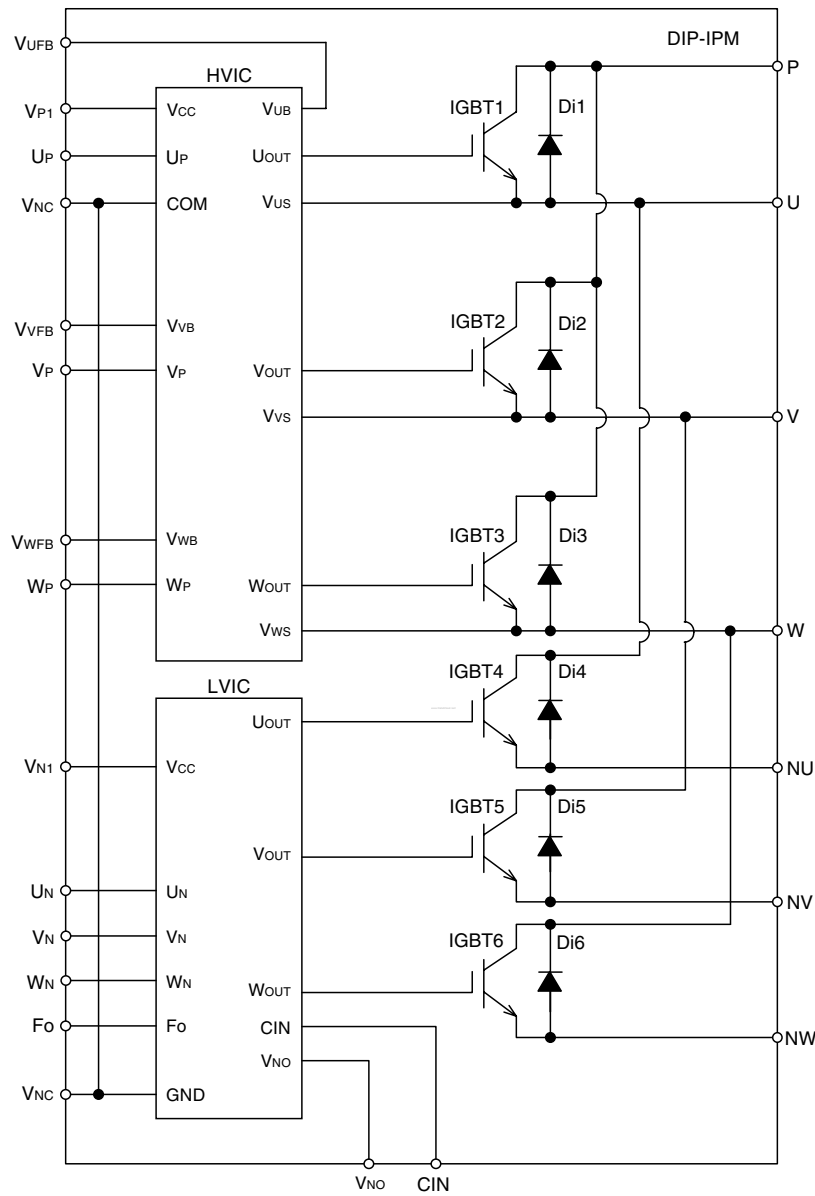
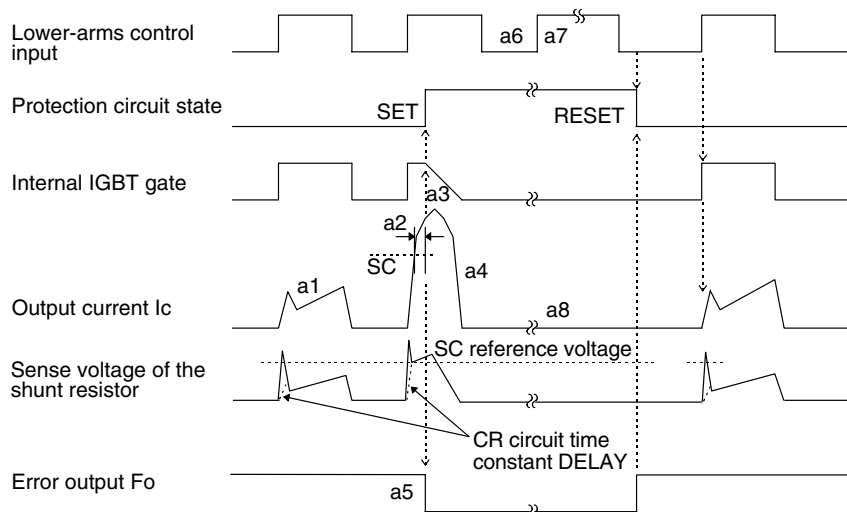

Fig. 3 TIMING CHART OF THE DIP-IPM PROTECTIVE FUNCTIONS

[A] Short-Circuit Protection (Lower-arms only with the external shunt resistor and CR filter)

- a1. Normal operation : IGBT ON and carrying current.
- a2. Short circuit detection (SC trigger).
- a3. IGBT gate hard interruption.
- a4. IGBT turns OFF.
- a5. Fo output ($t_{FO(min)} = 20\mu s$).
- a6. Input "L" : IGBT OFF.
- a7. Input "H" : IGBT ON.
- a8. IGBT OFF in spite of input "H".



[B] Under-Voltage Protection (Lower-arm, UVd)

- b1. Control supply voltage rises : After the voltage level reaches UV_{Dr} , the circuits start to operate when next input is applied.
- b2. Normal operation : IGBT ON and carrying current.
- b3. Under voltage trip (UV_{Dt}).
- b4. IGBT OFF in spite of control input condition.
- b5. Fo output ($t_{FO} \geq 20\mu s$ and Fo output continuously during UV period).
- b6. Under voltage reset (UV_{Dr}).
- b7. Normal operation : IGBT ON and carrying current.

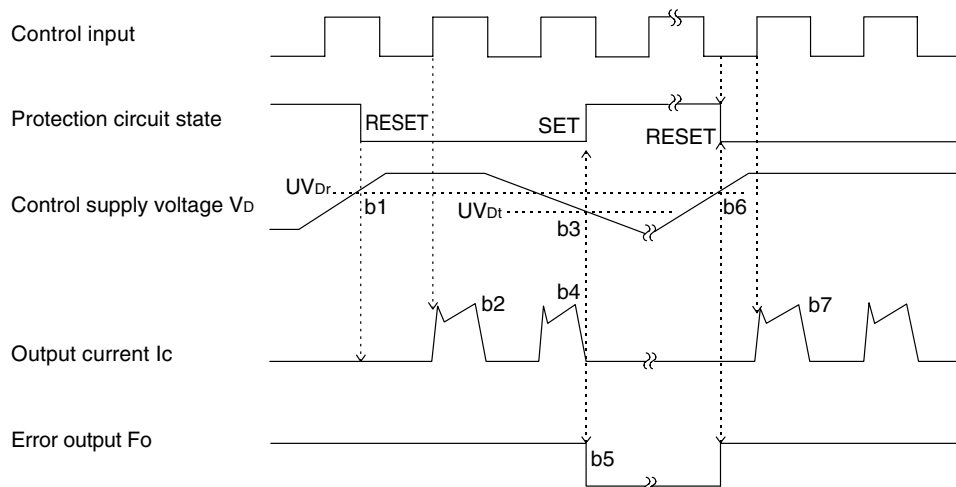

[C] Under-Voltage Protection (Upper-arm, UVDB)

- c1. Control supply voltage rises : After the voltage reaches UVDBr, the circuits start to operate when next input is applied.
- c2. Normal operation : IGBT ON and carrying current.
- c3. Under voltage trip (UVDBt).
- c4. IGBT OFF in spite of control input signal level, but there is no Fo signal output.
- c5. Under voltage reset (UVDBr).
- c6. Normal operation : IGBT ON and carrying current.

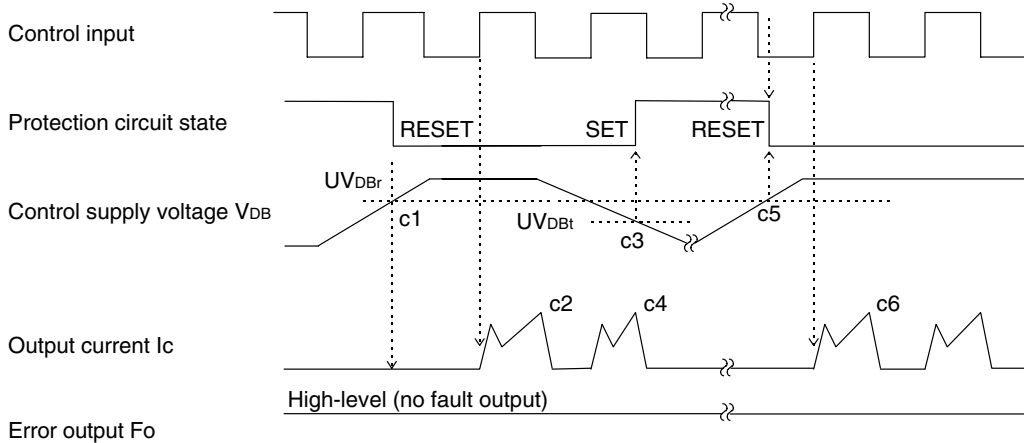
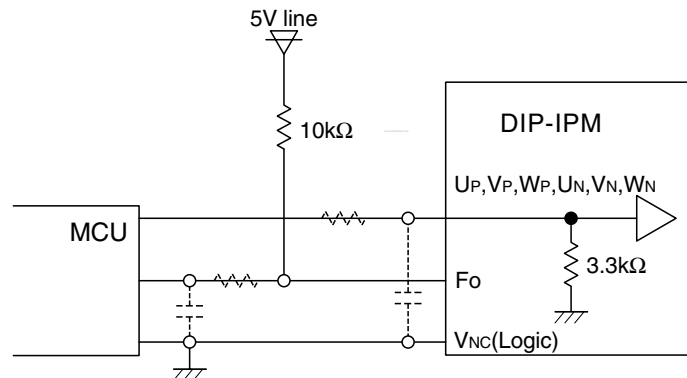

Fig. 4 RECOMMENDED MCU I/O INTERFACE CIRCUIT



Note : The setting of RC coupling at each input (parts shown dotted) depends on the PWM control scheme and the wiring impedance of the printed circuit board.
The DIP-IPM input section integrates a 3.3kΩ (min) pull-down resistor. Therefore, when using an external filtering resistor, pay attention to the turn-on threshold voltage.

Fig. 5 WIRING CONNECTION OF SHUNT RESISTOR

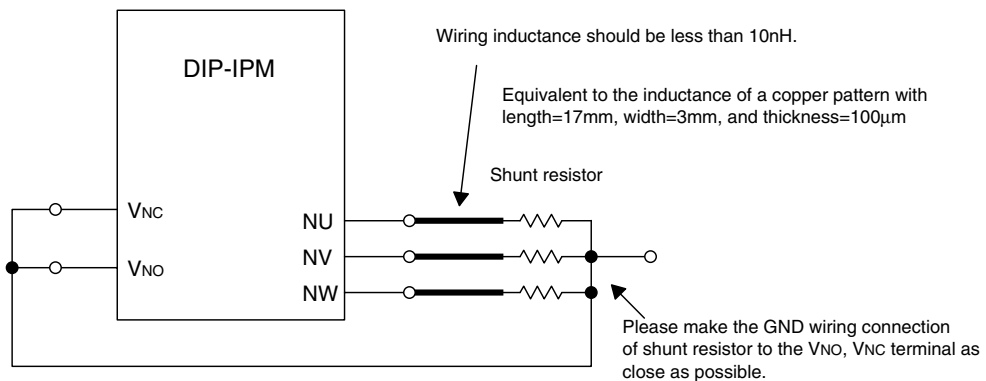
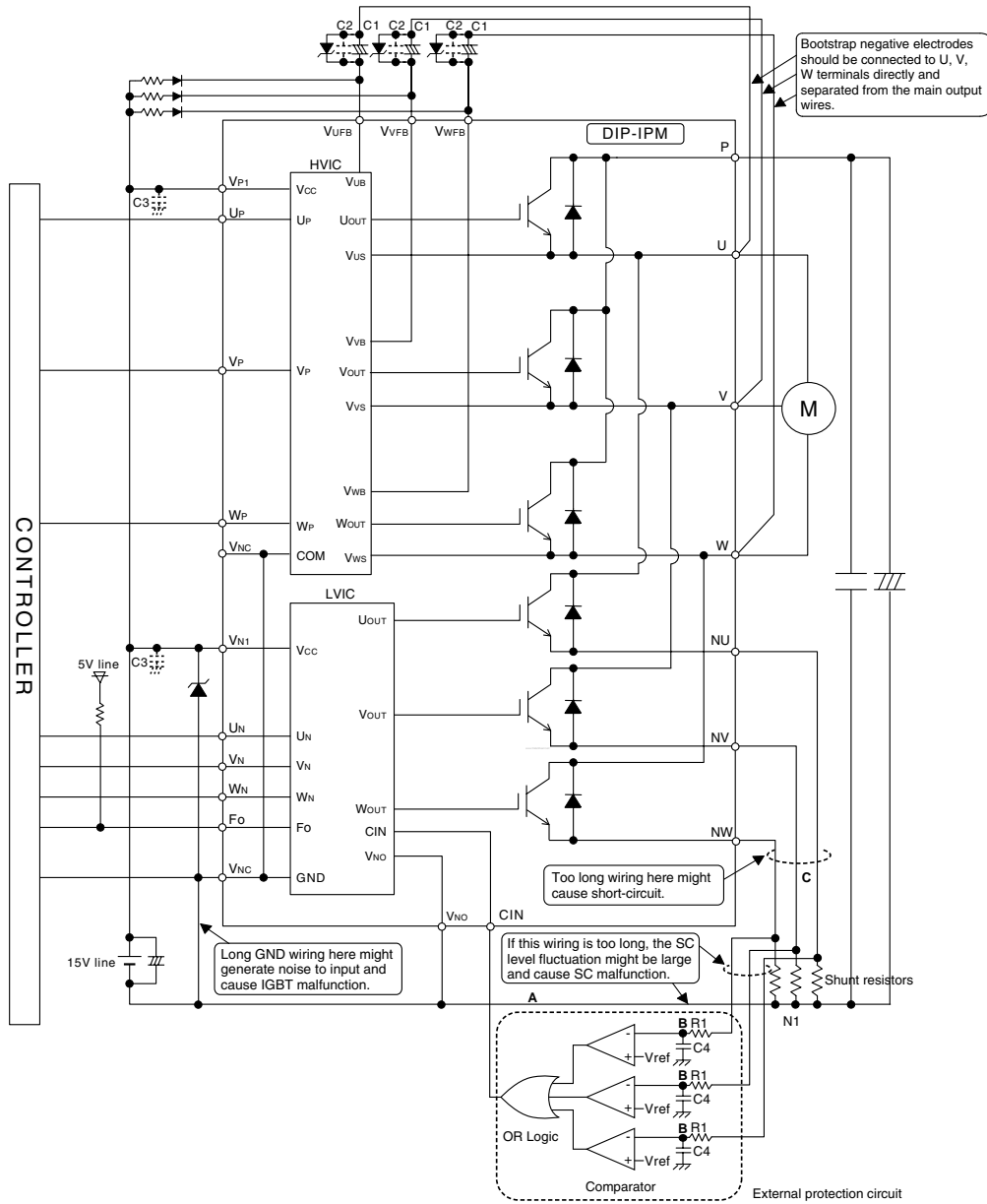

Fig. 6 TYPICAL DIP-IPM APPLICATION CIRCUIT EXAMPLE

C1:Tight tolerance temp-compensated electrolytic type C2,C3: 0.22~2μF R-category ceramic capacitor for noise filtering



- Note 1** : To prevent malfunction, the wiring of each input should be as short as possible (2~3cm).
- 2** : By virtue of integrating HVIC inside, direct coupling to MCU without opto-coupler or transformer isolation is possible.
- 3** : FO output is open drain type. It should be pulled up to a 5V supply with an approximately 10kΩ resistor.
- 4** : The logic of input signal is high-active. The DIP-IPM input signal section integrates a 3.3kΩ (min) pull-down resistor. If using external filtering resistor, ensure the voltage drop of ON signal not below the threshold value.
- 5** : To prevent malfunction of protection, the wiring of A, B, C should be as short as possible.
- 6** : Please set the filter R1•C4 time constant such that the IGBT can be interrupted within 2μs.
- 7** : Each capacitor should be located as nearby the pins of the DIP-IPM as possible.
- 8** : To prevent surge destruction, the wiring between the smoothing capacitor and the P-N1 pins should be as short as possible. Approximately a 0.1~0.22μF snubber capacitor between the P-N1 pins is recommended.
- 9** : Make external wiring connection between VNO and VNC terminals as shown in Fig.5.
- 10** : Two VNC terminals (9 & 16 pin) are connected inside DIP-IPM, please connect either one to the 15V power supply GND outside and leave another one open.
- 11** : To prevent ICs from surge destruction, it is recommended to insert a Zener diode (24V, 1W) between each control supply terminals.
- 12** : The reference voltage Vref of comparator should be set up the same rating of short circuit trip level (Vsc(ref): min.0.43V to max.0.53V).
- 13** : OR logic output level should be set up the same rating of short circuit trip level (Vsc(ref): min.0.43V to max.0.53V).