

### FEATURES

- **HIGH ISOLATION VOLTAGE (BV)**  
5000 Vr.m.s.: normal specification products
- **HIGH COLLECTOR TO EMITTER VOLTAGE**  
 $V_{CE0} = 80 \text{ V MIN}$
- **HIGH CURRENT TRANSFER RATIO**  
CTR: 200% TYP
- **HIGH SPEED SWITCHING**  
 $t_r = 3 \mu\text{s}$ ,  $t_f = 5 \mu\text{s}$  TYP
- **ISOLATED CHANNELS PER EACH PACKAGE**

### DESCRIPTION

NEC's PS2561-1, -2 and -4 and PS2561L-1, -2 and -4 are optically coupled isolators containing a GaAs light emitting diode and a NPN silicon phototransistor. PS2561-1, -2 and -4 are in a plastic DIP (Dual In-line Package) and PS2561L-1, -2 and -4 are in a lead bending type (Gull-wing) for surface mount.

### APPLICATIONS

Interface circuit for various instrumentations, and control equipment.

- AC LINE / DIGITAL LOGIC
- DIGITAL LOGIC / DIGITAL LOGIC
- TWISTED PAIR LINE RECEIVER
- TELEPHONE / TELEGRAPH LINE RECEIVER
- HIGH FREQUENCY POWER SUPPLY  
FEEDBACK CONTROL
- RELAY CONTACT MONITOR
- POWER SUPPLY MONITOR

### ELECTRICAL CHARACTERISTICS (TA = 25°C)

		PART NUMBER		PS2561-1, -2, -4 PS2561L-1, -2, -4			
		SYMBOLS	PARAMETERS	UNITS	MIN	TYP	MAX
Diode		V <sub>F</sub>	Forward Voltage, I <sub>F</sub> = 10 mA	V		1.17	1.4
		I <sub>R</sub>	Reverse Current, V <sub>R</sub> = 5 V	μA			5
		C	Junction Capacitance, V = 0, f = 1.0 MHz	pF		50	
Transistor		I <sub>CEO</sub>	Collector to Emitter Dark Current, V <sub>CE</sub> = 40 V, I <sub>F</sub> = 0	nA			100
		BV <sub>CEO</sub>	Collector to Emitter Breakdown Voltage, I <sub>C</sub> = 1 mA, I <sub>B</sub> = 0	V	40	60	
		BV <sub>ECO</sub>	Emitter to Collector Breakdown Voltage, I <sub>E</sub> = 100 μA, I <sub>B</sub> = 0	V	7	9	
Coupled		CTR	Current Transfer Ratio <sup>1</sup> , I <sub>F</sub> = 5 mA, V <sub>CE</sub> = 5 V	%	80	200	400
		V <sub>CE(sat)</sub>	Collector Saturation Voltage, I <sub>F</sub> = 10 mA, I <sub>C</sub> = 2 mA	V			0.3
		R <sub>1-2</sub>	Isolation Resistance, V <sub>in-out</sub> = 1 k V	Ω	10 <sup>11</sup>		
		C <sub>1-2</sub>	Isolation Capacitance, V = 0, f = 1.0 MHz	pF		0.5	
		t <sub>r</sub>	Rise Time <sup>2</sup> , V <sub>CC</sub> = 10 V, I <sub>C</sub> = 2 mA, R <sub>L</sub> = 100 Ω	μs		3	
	t <sub>f</sub>	Fall Time <sup>2</sup> , V <sub>CC</sub> = 10 V, I <sub>C</sub> = 2 mA, R <sub>L</sub> = 100 Ω	μs		5		

Note:

1. CTR Rank (PS2561-1, PS2561L-1 Only)  
L: 200 to 400 %  
M: 80 to 240 %  
D: 100 to 300 %  
H: 80 to 160 %  
W: 130 to 260 %

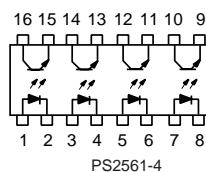
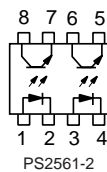
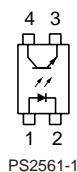

2. Test Circuit for Switching Time

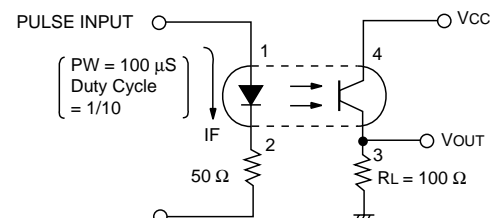

**ABSOLUTE MAXIMUM RATINGS<sup>1</sup>** (T<sub>A</sub> = 25°C)

SYMBOLS	PARAMETERS	UNITS	RATINGS	
			PS2561 -1 PS2561L -1	PS2561 -2,-4 PS2561L -2,-4
Diode				
V <sub>R</sub>	Reverse Voltage	V	6	6
I <sub>F</sub>	Forward Current (DC)	mA	80	80
P <sub>D</sub>	Power Dissipation	mW/Ch	150	120
I <sub>F</sub> (PEAK)	Peak Forward Current (PW = 100 μs, Duty Cycle 1%)	A	1	1
Transistor				
V <sub>CEO</sub>	Collector to Emitter Voltage	V	80	80
V <sub>ECO</sub>	Emitter to Collector Voltage	V	7	7
I <sub>C</sub>	Collector Current	mA	50	50
P <sub>C</sub>	Power Dissipation	mW/Ch	150	120
Coupled				
BV	Isolation Voltage <sup>2</sup> normal spec	V <sub>r.m.s.</sub>	5000	5000
BV	Isolation Voltage <sup>2</sup> VDE0884 spec	V <sub>r.m.s.</sub>	3750	3750
P <sub>T</sub>	Total Power Dissipation	mW/Ch	250	200
T <sub>STG</sub>	Storage Temperature	°C	-55 to +150	-55 to +150
T <sub>OP</sub>	Operating Temperature	°C	-55 to +100	-55 to +100
T <sub>SOL</sub>	Lead Temperature (Soldering 10 s)	°C	260	260

Notes:

1. Operation in excess of any one of these parameters may result in permanent damage.
2. AC voltage for 1 minute at T<sub>A</sub> = 25 °C, RH = 60 % between input and output.

**TYPICAL PERFORMANCE CURVES** (T<sub>A</sub> = 25°)

**DIODE POWER DISSIPATION vs. AMBIENT TEMPERATURE**

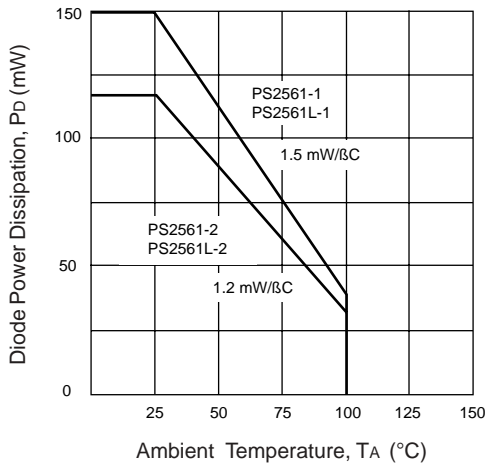

**TRANSISTOR POWER DISSIPATION vs. AMBIENT TEMPERATURE**

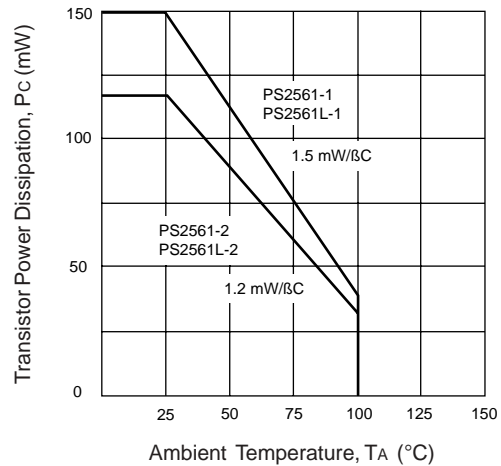

**FORWARD CURRENT vs. FORWARD VOLTAGE**

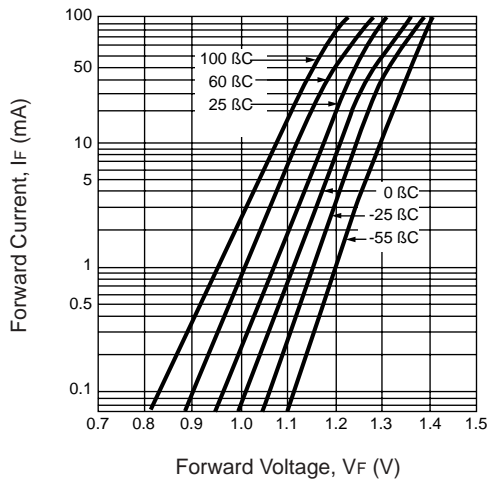

**COLLECTOR CURRENT vs. COLLECTOR to EMITTER VOLTAGE**

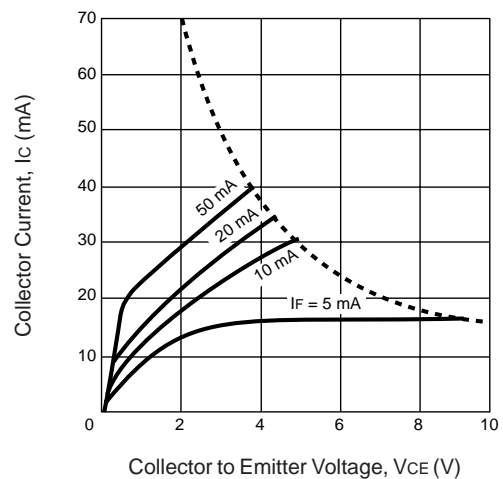

**TYPICAL PERFORMANCE CURVES** ( $T_A = 25^\circ\text{C}$ )

**COLLECTOR TO EMITTER DARK CURRENT vs. AMBIENT TEMPERATURE**

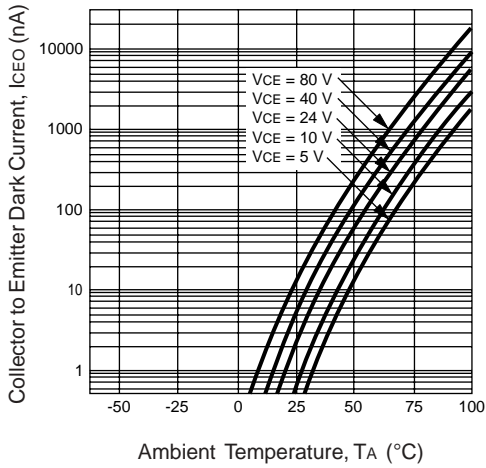

**COLLECTOR CURRENT vs. COLLECTOR SATURATION VOLTAGE**

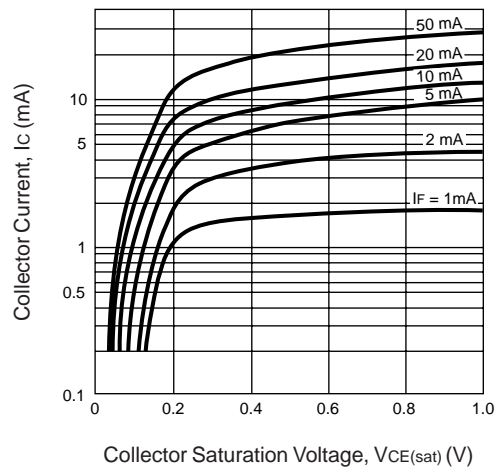

**NORMALIZED OUTPUT CURRENT vs. AMBIENT TEMPERATURE**

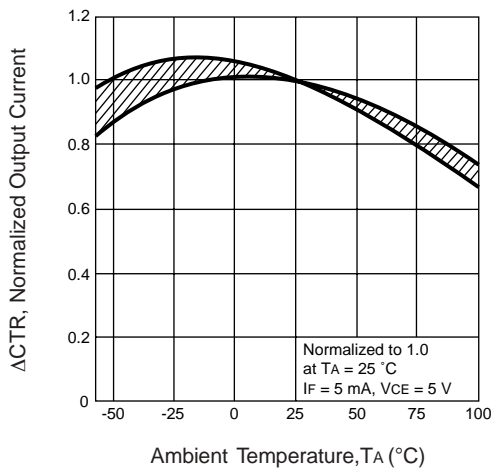

**CURRENT TRANSFER RATIO (CTR) vs. FORWARD CURRENT**

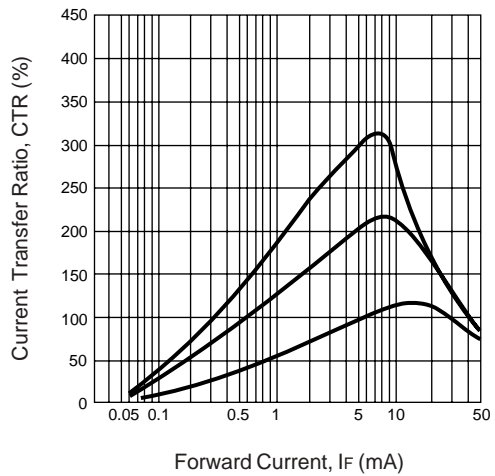

**SWITCHING TIME vs. LOAD RESISTANCE**

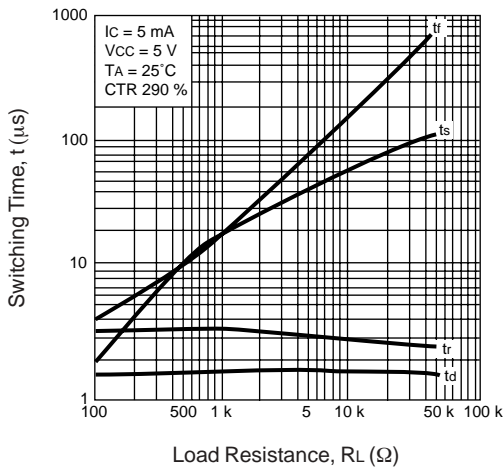

**SWITCHING TIME vs. LOAD RESISTANCE**

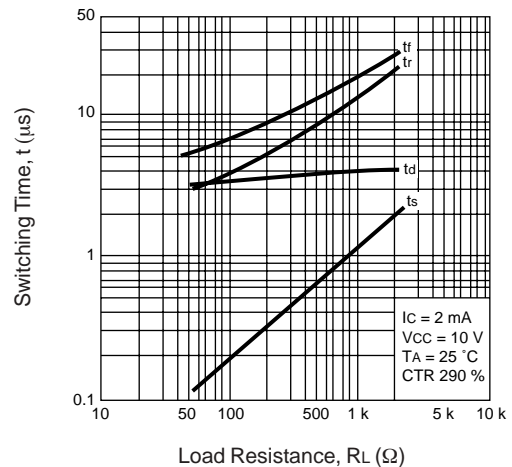

# PS2561-1, -2, -4 PS2561L-1, -2, -4

## TYPICAL PERFORMANCE CURVES (TA = 25°)

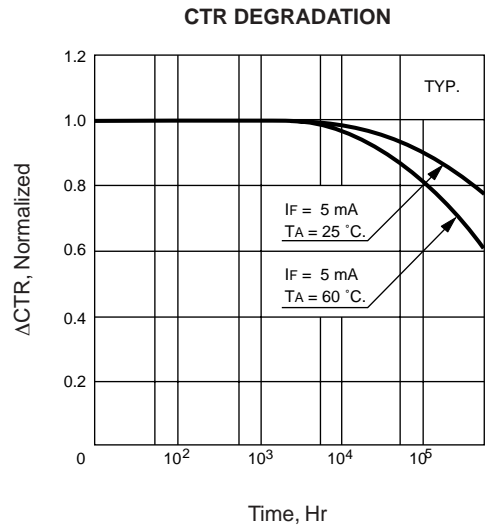
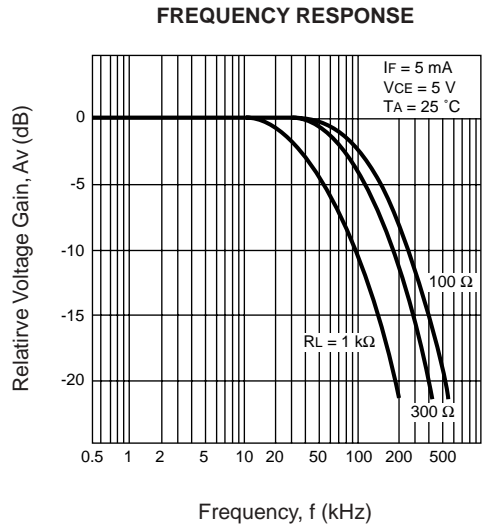

## OUTLINE DIMENSIONS (Units in mm) DIP (Dual In-Line Package)

PS2561-1

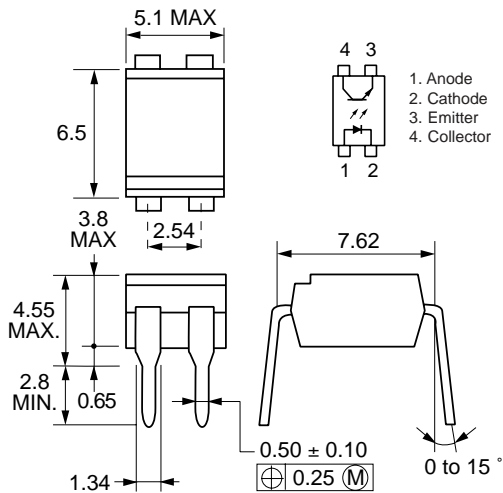

PS2561-2

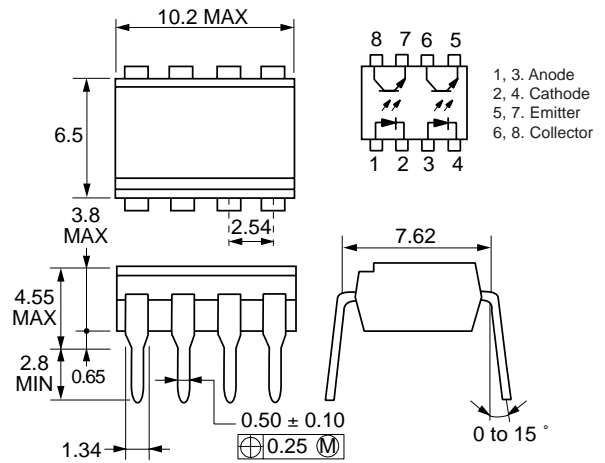

PS2561-4

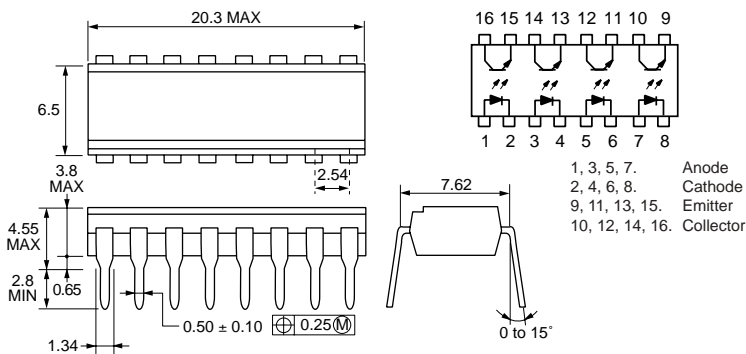

**OUTLINE DIMENSIONS** (Units in mm) Lead Bending type (Gull-Wing)

PS2561L-1

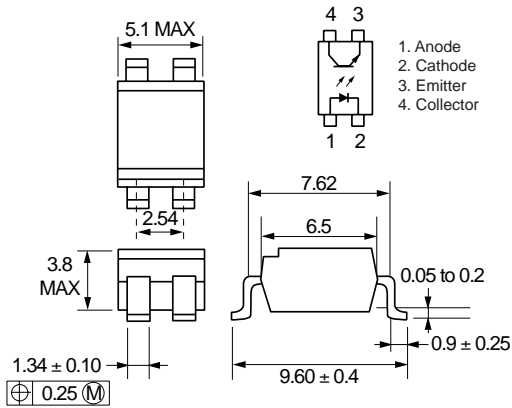

PS2561L-2

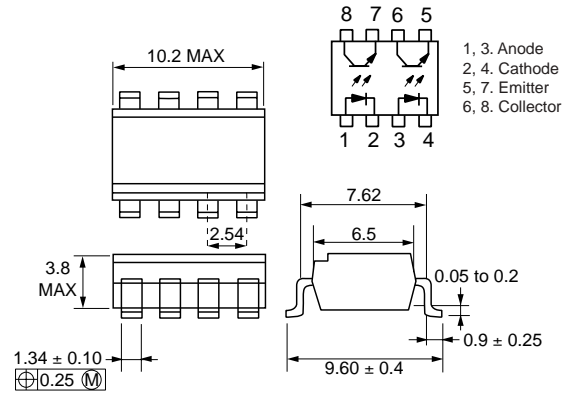

PS2561L-4

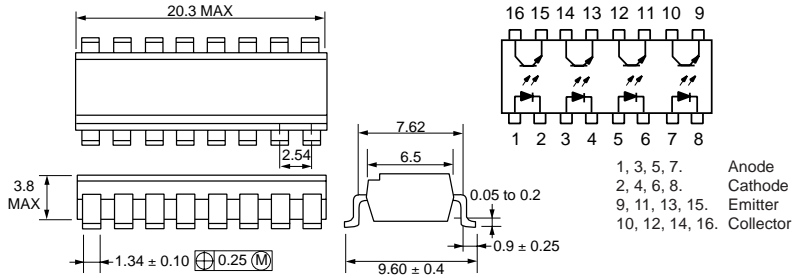

**OUTLINE DIMENSIONS** (Units in mm) DIP (Lead-Bending Type)

PS2561L1-1

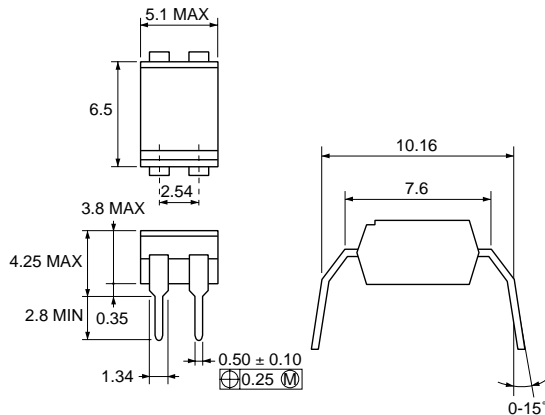

PS2561L2-1

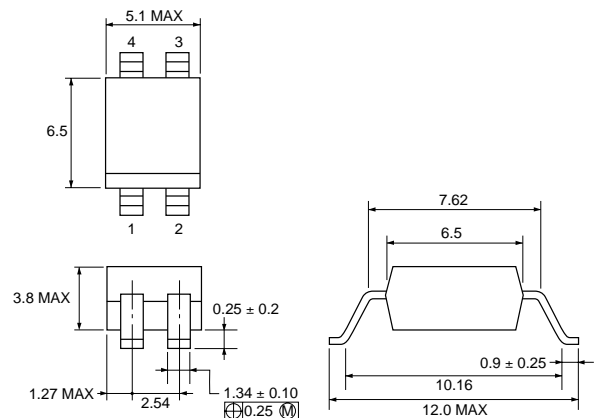

Life Support Applications

These NEC products are not intended for use in life support devices, appliances, or systems where the malfunction of these products can reasonably be expected to result in personal injury. The customers of CEL using or selling these products for use in such applications do so at their own risk and agree to fully indemnify CEL for all damages resulting from such improper use or sale.

**CEL** California Eastern Laboratories, Your source for NEC RF, Microwave, Optoelectronic, and Fiber Optic Semiconductor Devices.

4590 Patrick Henry Drive • Santa Clara, CA 95054-1817 • (408) 988-3500 • FAX (408) 988-0279 • [www.cel.com](http://www.cel.com)

DATA SUBJECT TO CHANGE WITHOUT NOTICE

10/14/2003