

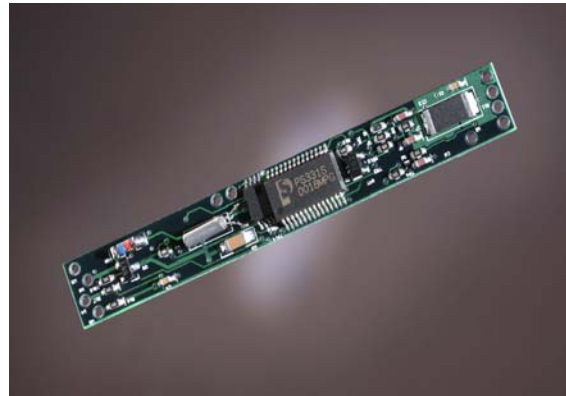

### Features

- Standard sized modules for assembly into custom and standard sized battery packs
- Designed to work with 2-4 cell series Li Ion or 6-10 cell series Ni pack configurations
  - Contains patented core calculation and battery control algorithms for Li Ion and NiMH chemistries
- Can be programmed with application specific cell parameters for NiMH and Li Ion chemistries
- Fully compliant with industry standard Smart Battery Data Specification V1.1a
  - SMBus V1.1 with PEC / CRC-8 communication with system host
- High accuracy measurement of charge / discharge current, voltage, and temperature with on-chip 14-bit integrating A/D
- Precise capacity reporting using PowerSmart patented algorithms and 3D battery cell models
- 3D models and “learned” parameters stored in on board EEPROM; fully field re-programmable via SMBus interface
- Extremely low power operation:
  - Sleep Mode: < 10 uA typical
  - Run Mode: < 500 uA typical
  - Sample Mode < 250 uA typical
- Complete hardware and software development tools available
- ESD protection – passes 8kV contact and 15kV air without capacity reset

### PCB Assembly



### Ordering Information

Pre-tested, fully assembled modules are available:

PS3110 – NiMH module  
PS3120 – Li Ion module

Please specify number of series cells when ordering.

### Quick Start

Follow these directions to assemble a pack with the PS3100 module.

- Use standard precautions when handling static sensitive devices.
- Modules should be connected to battery cells in the order indicated below to insure proper start-up and operation. Wires should be attached to the modules first and then connected to the battery cells as instructed.
- **The connection sequence is critical to successful use of the PS331 family of CMOS ASICs. The negative cell string connection should always be connected first, followed by the cell string positive connection. The remaining connections can then be made after the pack negative and pack positive are securely connected to the module.**

**Step 1)** Configure the module jumpers according to the following chart:

	<b>NiMH</b>	<b>Li Ion 2-cell</b>	<b>Li Ion 3-cell</b>	<b>Li Ion 4-cell</b>
<b>R12</b>	N/A	<b>Installed</b>	<b>Installed</b>	Removed
<b>R13</b>	N/A	<b>Installed</b>	Removed	Removed
<b>R14</b>	N/A	Removed	Removed	Removed
<b>R2</b>	Same as R1 (10K ohm @ 25°C)	365 ohms	365 ohms	365 ohms

**Step 2)** Connect wires to module. Use large diameter wire (18AWG-20 AWG) for current carrying lines from W1 and W2. All others are signal only lines (24 to 22 AWG).

**Step 3)** Connect W1 (BN) to the most negative point on the battery cell stack.

**Step 4)** Connect W6 (BP) to the most positive point on the battery cell stack.

**Step 5)** Li Ion Only: Connect cell voltage pickups at W3, W4, W5 as required (see diagrams).

**Step 6)** Connect external connector to W7, W8, W9.

**Step 7)** Li Ion Only: Connect safety electronics between W2 and external connector OR between the most positive point on the battery cell stack and the external connector.

**Step 8)** NiMH Only: Connect W2 to external connector. Connect most positive point on the battery stack to the external connector.

**Step 9)** Program the assembled pack using PowerSmart's SBTool software and calibration board or info board hardware and your \*.p3I file. Default \*.p3I files are available on the website ([www.powersmart.com](http://www.powersmart.com)).

**Step 10)** Calibrate the pack using the SBTool software and calibration board hardware. The pack is now ready for use.

### Connection Diagrams : Li Ion

A Li Ion safety circuit can be attached in either the positive (high-side) or negative (low-side) power path. **The only requirement is that the safety circuit is on the "connector" side of the module.** Each diagram contains an example but 4-cell can also use high-side safety and 3-cell can use low-side.

#### Li Ion 4-cell Connection Example

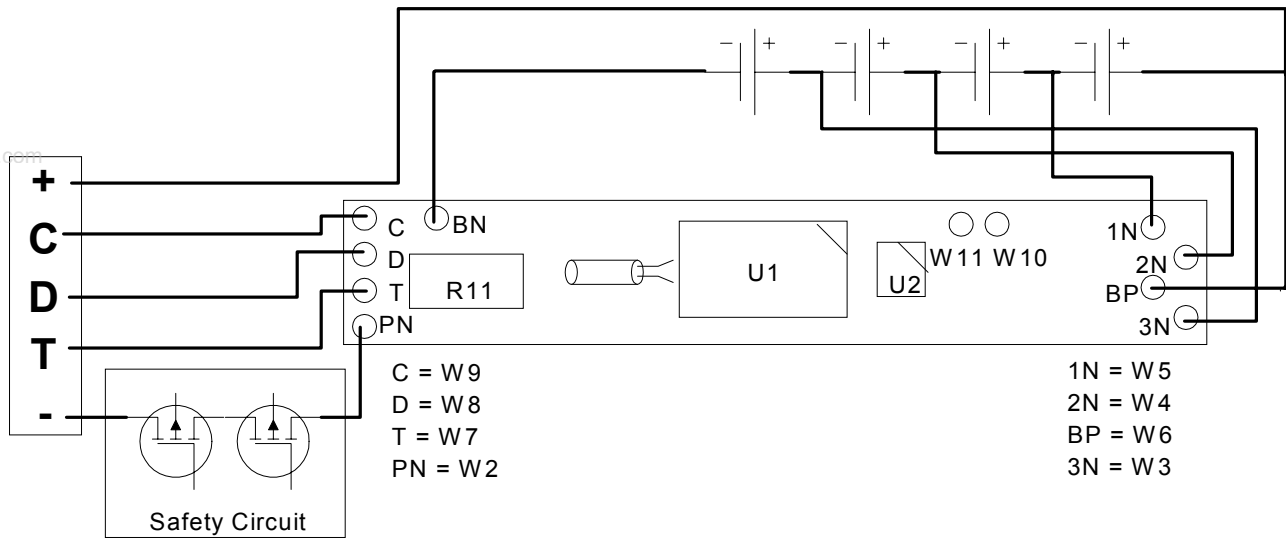

#### Li Ion 3-cell Connection Example

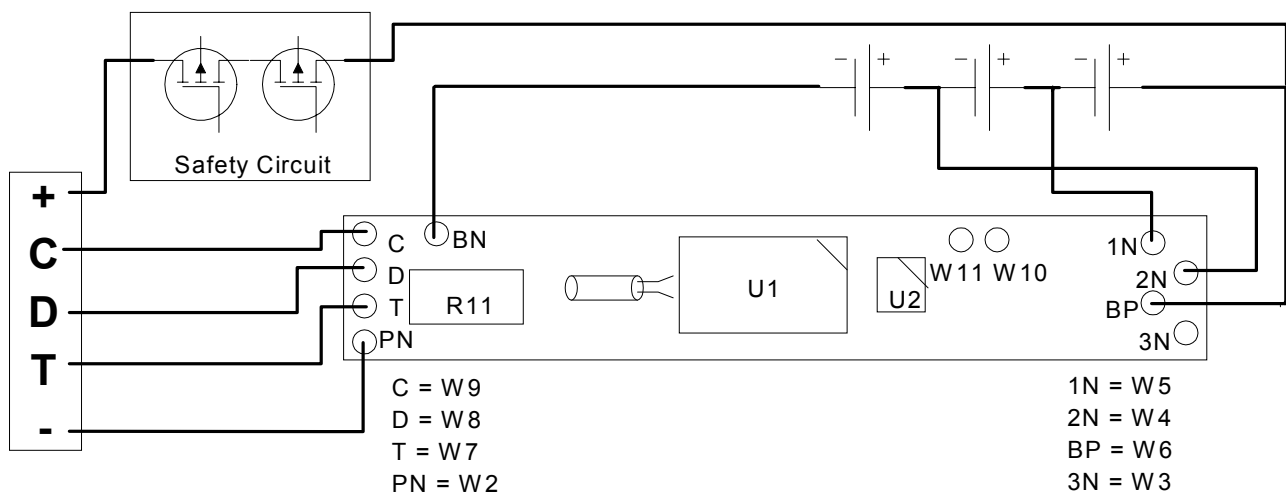

## Li Ion 2-cell Connection Example

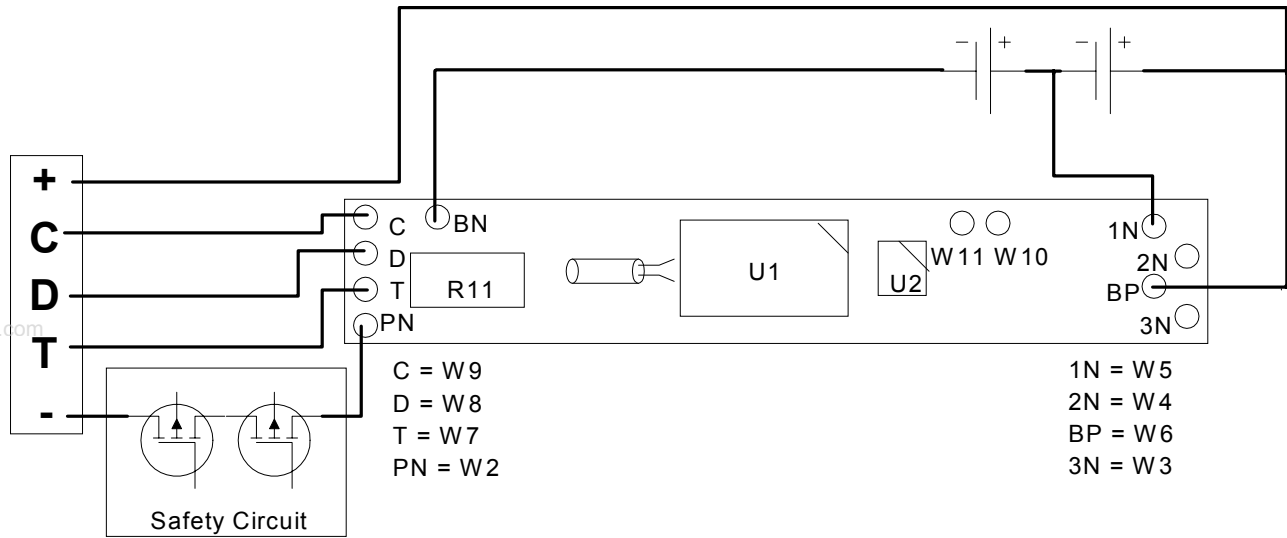

### Connection Diagrams: NiMH

Any number of series NiMH cells may use the same module configuration. Although the example shows 8 cells in series, any number from 6 to 10 may be used without changing any hardware on the module. R12, R13, and R14 may be either installed or removed without altering the module operation.

## NiMH Connection Example

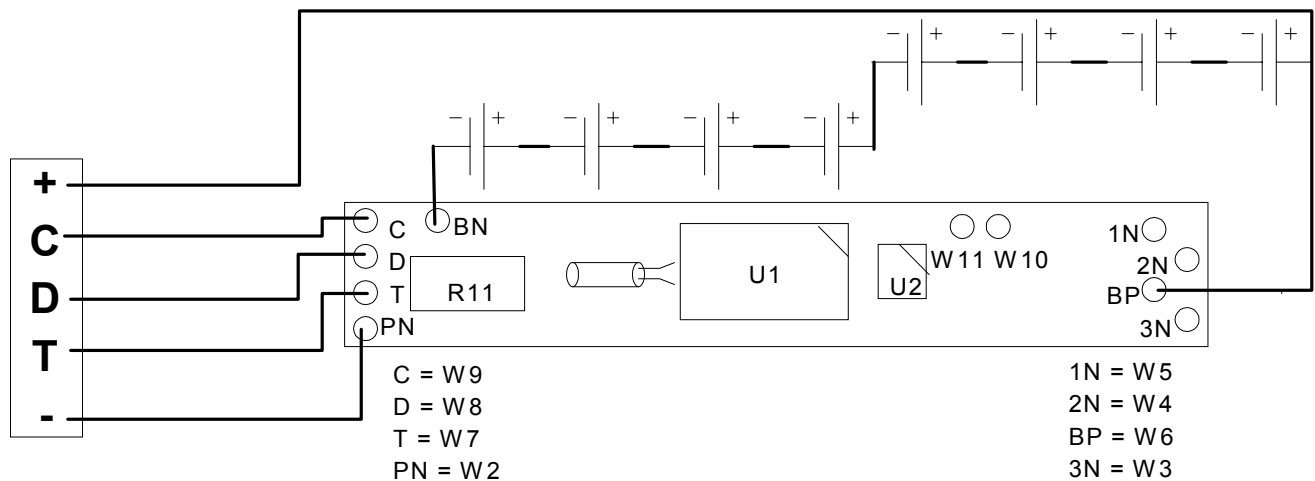

## Optional Connections

An on-board NTC thermistor (R1) is used by the P3 for internal pack temperature measurements. This is located as shown in the diagram below. This sensor may be moved to another location in the battery pack if desired. Connection points W10 and W11 may be used to install an off-board thermistor for remote temperature monitoring. If an off-board thermistor is installed, R1 should be removed.

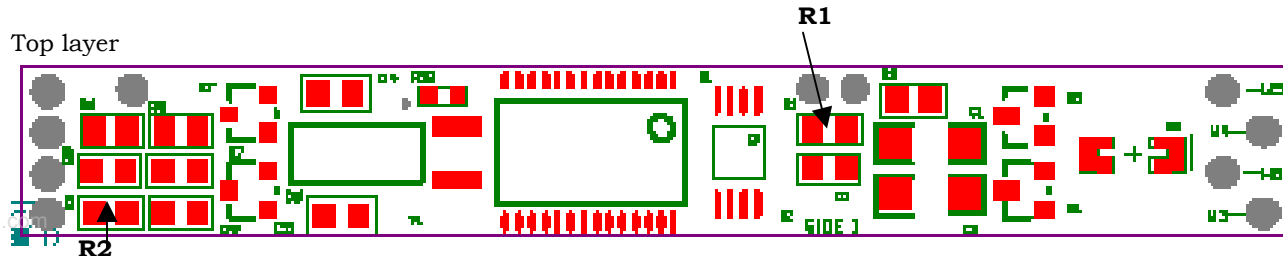

The R2 'pack thermistor' or 'T-pin' signal is used by external devices, such as chargers, to determine the chemistry of the battery pack or its temperature (using an external circuit.) The P3 module includes this 'T-pin' value at R2 as one of two values. As shown in the parts list, this may be either a NTC thermistor (same as R1) for NiMH applications or it may be a 365 ohm resistor for Li Ion applications.

## General Description

The PS3100 family of modules are complete fuel-gauge monitoring circuits without safety electronics and are ready for simple integration into a NiMH or Li Ion battery pack. They are sized to be used in-battery to monitor and control charge and discharge of a series/parallel battery configured for either 6 to 10-cell NiMH batteries or for 2 to 4-cell Li Ion batteries. These modules can be configured to work with either high-side or low-side Li Ion safety electronics.

Using just four external cell string connections, PowerSmart standard modules can be easily integrated in a battery pack. An optional 5-pin self-wiping Advanced Battery Interconnect can be integrated as part of the module assembly. The modules can fit between cylindrical cells or on the side of the pack with a nominal additional increase in size. The on-board four LED display can be used for a five level Relative or Absolute state-of-charge indicator.

The PS3100 family provides all of the SMBus and SBData protocols and data values ranging from state-of-charge (fuel-gauging) information to alarm and charger instruction broadcasts.

Charge and discharge currents, battery pack and cell voltages, and pack temperature measurements are done with the integrating dual-slope analog to digital converter at 10-bit to 14-bit resolution depending on the measurement.

Calculations are done with the 8-bit RISC CPU core. Communications use a hardware master-slave SMBus/I<sup>2</sup>C engine with byte-wise link to the CPU core. An 8K byte ROM and 128 bytes of RAM supply the CPU with instructions, chemistry models and operating memory. An internal RC oscillator is complemented with a low-cost, low-power external 32 kHz crystal for precise timing. External circuitry controls a voltage microregulator to supply the IC with a nominal 3.3 Volts. Also included with the external circuitry are thermistor conditioning and ESD suppression circuitry.

## Functional Description

PowerSmart standard modules are complete measurement, calculation, and communication modules specifically for Smart Battery System applications. The PS3100 utilize PowerSmart's P3 smart battery IC, which contains a multi-plexed 10 to 14-bit plus sign analog to digital converter, an 8-bit RISC microprocessor core, assorted RAM and ROM, and a hardware SMBus/I<sup>2</sup>C communications engine. All calculations conform to the Smart Battery Data Specification, Version 1.1 and all communications are compliant with System Management Bus Specification, version 1.1 as well.

These modules contain all SBS SMBus and SBData functionality on a single module for in-battery use. They

continuously monitor charge and discharge currents, battery pack cell voltages and temperature. Each module records and reports numerous data values including the present state of charge of the battery cells in percentages, Ampere-Hours, or Watt-hours. Additional data predicting both present and future operating time, charge time and operating capacity is also available. These P3 based modules also communicate various alarms when the predicted capacity is below a user-set limit (either time or capacity) and when the battery cells are completely empty. This allows a smart battery enabled system to fully use the battery energy without need for extensive 'buffers' to permit final suspend or save-to-disk operation.

Measurements of voltage, current, and temperature occur at set intervals controlled by a precise crystal oscillator circuit. Calculations of capacity, time remaining, state-of-charge, and self-discharge occur at similar intervals. Updated information is available via SMBus requests as defined by the version 1.1 SBData specification.



**Bill of Materials**

UNLESS OTHERWISE NOTED: RESISTORS ARE 5% TOLERANCE; VALUES IN OHMS  
CAPACITORS ARE: C0G -- +/-5%; X7R -- +/-10%; Y5V -- +80%/-20%

INDEX	REF. DES.	PART TYPE	VALUE	PACKAGE	QTY.	MANUFACTURER	MFR. PART NUMBER
1		FABRICATION		RAW BOARD	1	POWERSMART	B826020-05-01
2	C1 C3	CAPACITOR	330nf/X7R/25V	3216[1206]	2	VARIOUS	
3	C2	CAPACITOR	100nF/X7R/25V	2012[0805]	1	VARIOUS	
4	C4 C5 C8 C10	CAPACITOR	100nF/Y5V/25V	1608[0603]	4	VARIOUS	
5	C12	CAPACITOR	47pF/C0G/50V	1608[0603]	1	VARIOUS	
6	C13 C14	CAPACITOR	22pF/C0G/50V	1608[0603]	2	VARIOUS	*
7	D1 D2 D3 D4	LED	CCL-LX45GT	LED\TR8	4	LUMEX	SML-LX1206GC
8	D5	ZENER DIODE	ZMM5257B	DO-213AA\PS	1	DIODES INC.	ZMM5257BTR
9	D6 D7	ZENER DIODE	BZX84C5V6	SOT23	2	DIODES INC. ZETEX	BZX84C5V6 BZX84C5V6
10	D8	DIODE	BAT54C	SOT23	1	VARIOUS	
11	Q1	MOSFET	2N7002	SOT23-GSD	1	VARIOUS	
12	R1 R2	THERMISTOR	10K Thermistor	1608[0603]	2	SEMITEC	103KT1608-2P
13	R10	RESISTOR	4.7M	1608[0603]	1	VARIOUS	
14	R11	RESISTOR	25 mOhms (1%)	WSL2512	1	VISHAY	WSL2512-0.025-1%-R86
15	R12 R13 R14	RESISTOR	0 Ohm	1608[0603]	3	VARIOUS	
16	R3	RESISTOR	3.65K (1%)	1608[0603]	1	VARIOUS	
17	R4	RESISTOR	56	1608[0603]	1	VARIOUS	
18	R5 R6 R7 R8 R15 R16 R17 R18 R19	RESISTOR	510	1608[0603]	9	VARIOUS	
19	R9	RESISTOR	100	1608[0603]	1	VARIOUS	
20	S1	SWITCH	SKQGADE010	5.2x6.4mm--SM	1	ALPS	SKQGADE010
21	U1	IC	PS331S	SSOP28	1	POWERSMART	PS331S
22	U2	IC	M25LC040	TSSOP-8	1	MICROCHIP	25LC040/ST
23	Y1	CRYSTAL	32.768 KHz (100 ppm 12-12.5pF)	XTAL\MX1	1	MICROCRYSTAL  EPSON  SEIKO CITIZEN	MX1V-TL-32.768K-12.5pF-100ppm C-002RX 32.7680K-A ** VT-200 12.5pF ** CMR200TB 12.5pF

\* NOTE: THESE CAPS ARE ONLY USED WHEN (1) A VERSION OF THE PS331 IC PRIOR TO VERSION 3.5 IS INSTALLED AT U1, AND(2) AN EPSON, SEIKO, OR CITIZEN CRYSTAL IS USED IN SUCH AN ASSEMBLY.

\*\* NOTE: EPSON AND SEIKO CRYSTALS ARE NOT SUITABLE FOR REFLOW SOLDERING -- MUST BE HAND-SOLDERED AFTER REFLOW.



### Development Tool Summary

PowerSmart provides all the necessary hardware and software to enable easy tailoring of battery control algorithm parameters and cell performance models to meet specific application requirements and attain the highest accuracy available anywhere. Table 1 summarizes the development tool offering from PowerSmart to support the PS331. Please refer to the PowerSmart web site for ordering information and design documentation (including schematics) at [www.powersmart.com](http://www.powersmart.com).

**Table 1:**

<b>Development Tool</b>	<b>Use</b>
P3 Info Board with SBTool software	Read and write Smart Battery data values, EEPROM programming
P3 Calibration System with SBTool software	Read and write Smart Battery data values, EEPROM programming, pack calibration
P3 Workbook	Develop files used to program EEPROM

### Reference Documents

This data sheets provides an overview of the PS3100 Multi-chemistry Module. It provides a detailed description of features and specifications that are unique to the PS3100. For further information on P3 device and development tool operations, please refer to the following documents available for download at [www.powersmart.com](http://www.powersmart.com):

PS331 Data Sheet

P3 Family User's Guide

Applications Notes:

- P3 Ex. Connection Diagrams
- P3 PC Board Layout Guide
- P3 Temperature Alarm Operation
- P3 Calibration Explanations

Development Tool Documentation:

- Lithium Ion Workbook Guide
- SBTool User's Guide
- P3 Eval System Data Sheet
- P3 Cal System Data Sheet
- P3 Info / Test Board Data Sheet

SBToolBox Data Sheet

### Mechanical Dimensions (units are mils)

Top layer

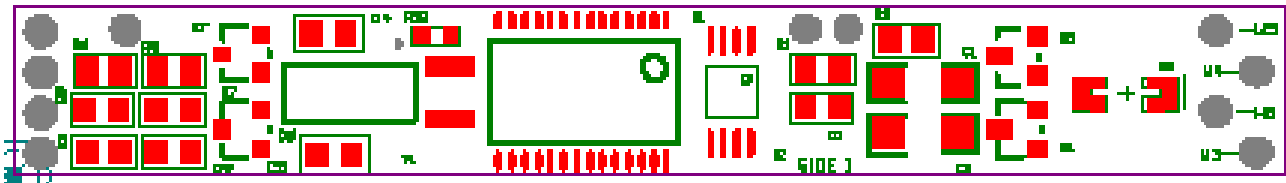

Bottom layer

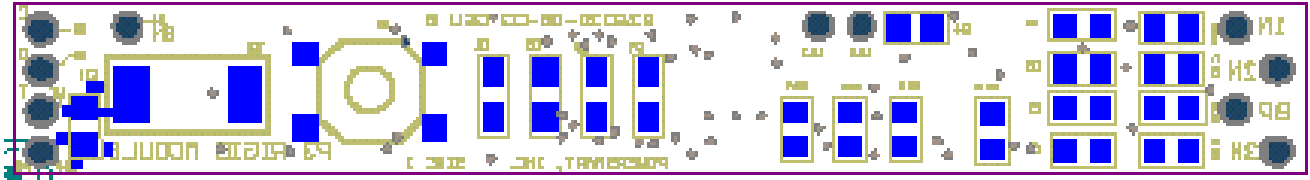

Dimensions

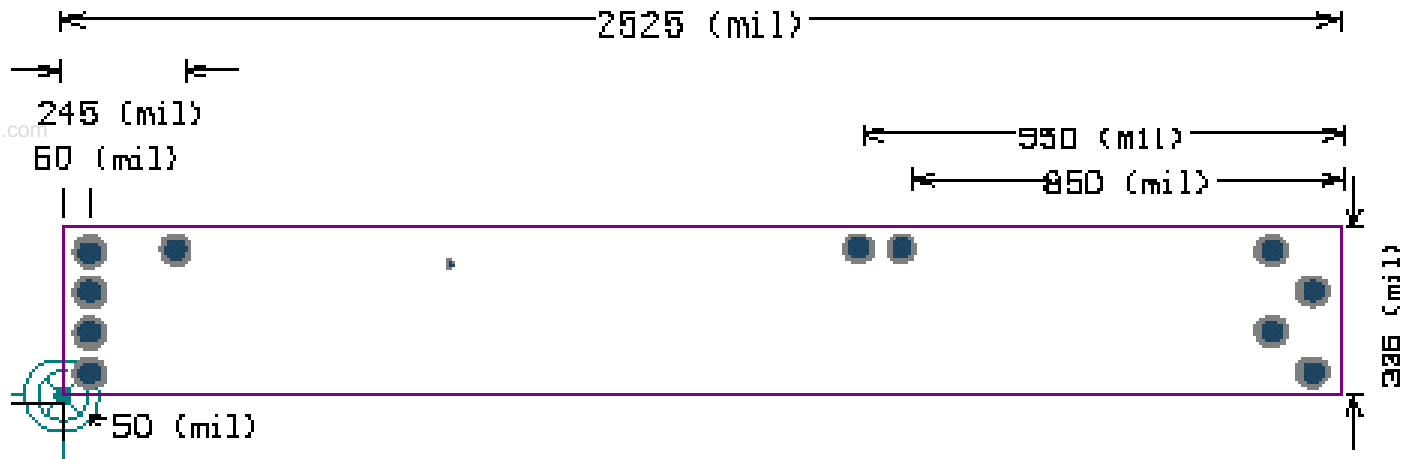

Quality Control

PowerSmart, Inc., has received ISO-9001 certification through TUV Rheinland of North America, based in Newtown, Conn. ISO-9001 certification indicates that PowerSmart has met strict international standards of quality control in manufacturing systems including product design, production, training, and inspection and testing. PowerSmart received certification for a quality system for the Design and Development of Battery Control Integrated Circuits, Software, Modules, Chargers, and Systems. PowerSmart, Inc., provides smart battery and charger electronics designed for use with all battery chemistries, bringing a new level of accuracy, reliability and customization not available before with other smart battery ICs.

Notice

PowerSmart products are not authorized for use as critical components of life support devices or systems. Seller disclaims any warranty or responsibility for such usage, which shall be at buyer's sole risk, notwithstanding any prior notice to seller of such usage or intended usage.

As used herein, "life support devices or systems" are devices or systems that are intended for implant, and whose failure to perform in such function can be reasonably expected to result in significant injury to the user. A "critical component" is any component of a life support device or system whose failure to perform can reasonably be expected to cause or result in the failure of performance of a life support device or system or to adversely affect its safety or effectiveness.