

Precision 8-Ch, Diff. 4-Ch, 17V Analog Multiplexers

Features

- Low On-Resistance (60-ohm typ.) Minimizes Distortion and Error Voltages
- Low Glitching Reduces Step Errors and Improves Settling Times. Charge Injection: <5pC
- Split-Supply Operation (+3V to +8V)
- Improved Second Sources for MAX398/MAX399
- On-Resistance Matching Between Channels: <60Ohm
- On-Resistance Flatness: <11-ohm
- Low Off-Channel Leakage,
I_{NO(OFF)} < 1nA @ +85oC, I_{COM(ON)}, <2.5nA @ +85oC
- TTL/CMOS Logic Compatible
- Fast Switching Speed, t_{TRANS} <250ns
- Break-Before-Make action eliminates momentary crosstalk
- Rail-to-Rail Analog Signal Range
- Low Power Consumption, <300μW
- Packaging (Pb-free & Green):
 - 16-pin SOIC (W)

Applications

- Data Acquisition Systems
- Audio Switching and Routing
- Test Equipment
- PBX, PABX
- Telecommunication Systems
- Battery-Powered Systems

Block Diagrams and Pin Configurations

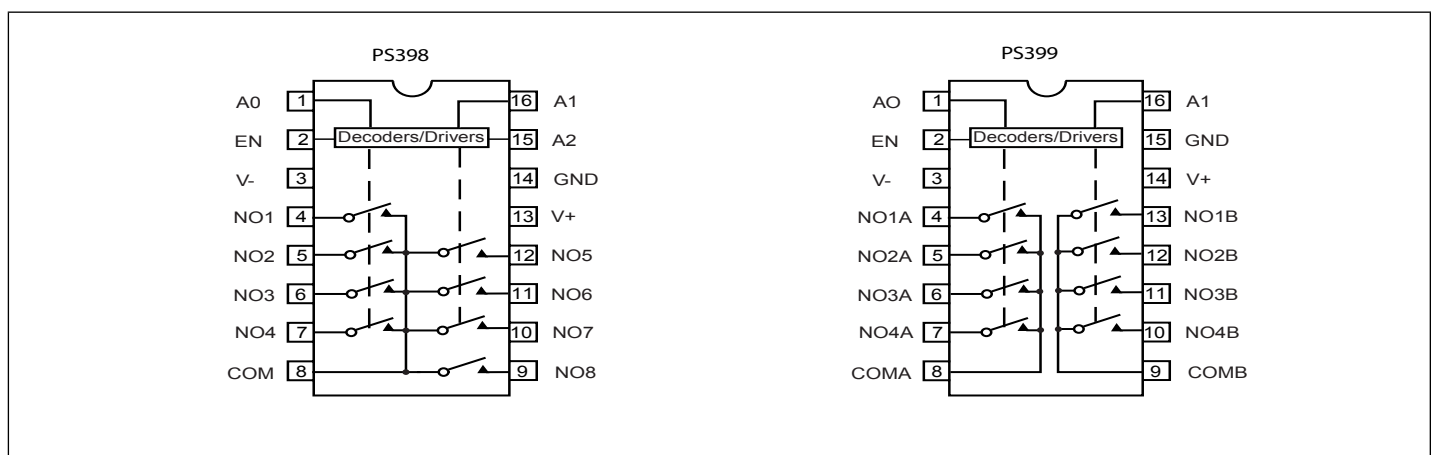

Description

The PS398/PS399 are improved high precision analog multiplexers. The PS398, an 8-channel single-ended mux, selects one of eight inputs to a common output as determined by a 3-bit address A0-A2. An EN (enable) pin when low disables all switches, useful when stacking several devices. The PS399 is a 4-channel differential multiplexer. It selects one of four differential inputs to a common differential output as determined by a 2-bit address A0, A1. An EN pin may be driven low to disable all switches.

These multiplexers operate with dual supplies from +3V to +8V. Single-supply operation is possible from +3V to +15V. With +5V power supplies, the PS398/PS399 guarantee <100-ohm on-resistance. On-Resistance matching between channels is within 6-ohm. On-Resistance flatness is less than 11-ohm over the specified signal range.

Each switch conducts current equally well in either direction when on. In the off state each switch blocks voltages up to the powersupply rails.

Both devices guarantee low leakage currents (<2.5nA at +85oC) and fast switching speeds (t_{TRANS} <250ns). Break-before-make switching action protects against momentary crosstalk between channels.

Truth Tables

PS398				
A2	A1	A0	EN	On Switch
X	X	X	0	None
0	0	0	1	1
0	0	1	1	2
0	1	0	1	3
0	1	1	1	4
1	0	0	1	5
1	0	1	1	6
1	1	0	1	7
1	1	1	1	8

PS399			
A1	A0	EN	On Switch
X	X	0	None
0	0	1	1
0	1	1	2
1	0	1	3
1	1	1	4

Logic "0", $V_{AL} \leq 0.8V$

Logic "1", $V_{AH} \geq 2.4V$

Absolute Maximum Ratings

Parameter	Min.	Max.	Units
Voltages Referenced to V-			
V+	-0.3	17	V
GND	-0.3	17	
GND	-0.3	(V+) + 0.3V	
$V_{IN}, V_{COM}, V_{NO}^{(1)}$	(V-)-2	(V+) +2V	
Current (any terminal)		30	mA
Peak Current, COM, NO, NC (pulsed at 1ms, 10% duty cycle)		100	
ESD per Method 3015.7	>2000		V
Continuous Power Dissipation			
SOIC (derate 8.7mW/ °C above +70°C)		650	mW
Storage Temperature	-65	150	°C
Lead Temperature (soldering, 10s)		300	

Stress beyond those listed under "Absolute Maximum Ratings" may cause permanent damage to the device.

Note:

1. Signals on NO, COM, or logic inputs exceeding V+ or V- are clamped by internal diodes. Limit forward diode current to 30mA.

Electrical Specifications - Dual Supplies ($V_{\pm} = \pm 5V \pm 10\%$, $GND = 0V$, $V_{AH} = V_{ENH} = 2.4V$, $V_{AL} = V_{ENL} = 0.8V$)

Parameters	Symbol	Conditions	Temp (°C)	Min ⁽²⁾	Typ ⁽¹⁾	Max ⁽²⁾	Units
Analog Switch							
Analog Signal Range ⁽³⁾	V_{ANALOG}		Full	V-		V+	V
On-Resistance	R_{ON}	$V_{+} = 4.5V, V_{-} = -4.5V,$ $V_{COM} = \pm 3.5V,$ $I_{NO} = 1mA$	25		60	100	ohm
			Full			125	
On-Resistance Match Between Channels ⁽⁴⁾	ΔR_{ON}	V_{COM} or $V_{NC} = \pm 3.5V,$ $I_{NO} = 1mA,$ $V_{+} = 5V, V_{-} = -5V$	25			6	
			Full			8	
On-Resistance Flatness ⁽⁵⁾	$R_{FLAT(ON)}$	$V_{+} = 5V, V_{-} = -5V,$ $I_{NO} = 1mA,$ $V_{COM} = \pm 3V, 0V$	25			11	
			Full			14	
NO Off Leakage Current ⁽⁶⁾	$I_{NO(OFF)}$	$V_{+} = 5.5V, V_{-} = -5.5V,$ $V_{COM} = \pm 4.5V,$ $V_{NO} = \pm 4.5V$	25	-0.1		0.1	
			Full	-1.0		1.0	
COM Off Leakage Current ⁽⁶⁾	$I_{COM(OFF)}$	$V_{+} = 5.5V, V_{-} = -5.5V$ $V_{COM} = \pm 4.5V,$ $V_{NO} = -/+4.5V$	PS398	25	-0.2		50
				Full	-2.5		100
			PS399	25	-0.1		50
				Full	-1.5		100
COM On Leakage Current ⁽⁷⁾	$I_{COM(ON)}$	$V_{+} = 5.5V, V_{-} = -5.5V$ $V_{COM} = \pm 4.5V$ $V_{NO} = 4.5V$	PS398	25	-0.4		0.4
				Full	-5		5
			PS399	25	-0.2		0.2
				Full	-2.5		2.5
Logic Input							
Logic High Input Voltage	V_{AH}, V_{ENH}		Full	2.4			V
Logic Low Input Voltage	V_{AL}, V_{ENL}					0.8	
Input Current with Input Voltage High	I_{AH}, I_{ENH}	$V_A = V_{EN} = 2.4V$		-0.1		0.1	μA
Input Current with Input Voltage Low	I_{AL}, I_{ENL}	$V_A = V_{EN} = 0.8V$		-0.1		0.1	

Dynamic								
Transition Time	t _{TRANS}	Figure 1				150	ns	
Break-Before-Make Time Delay	t _{OPEN}	Figure 3		0	40			
Enable Turn-On Time	t _{ON(EN)}	Figure 2	25		72	150		
			Full			250		
Enable Turn-Off Time	t _{OFF(EN)}	Figure 2	25		55	150		
			Full			200		
Charge Injection ⁽³⁾	Q	C _L = 1nF, V _S = 0V, R _S = 0Ohm,	25		2.8	5	pC	
Off Isolation ⁽⁷⁾	OIRR	V _{EN} = 0V, R _L = 1kOhm, f = 100kHz			-101			dB
Crosstalk	X _{TALK}	R _L = 1kOhm, f = 100kHz, Figure 6			-92			
Logic Input Capacitance	C _{IN}	f = 1MHz			2.5			pF
NO Off Capacitance	C _(OFF)	f = 1MHz, V _{EN} = V _{NO} = 0V			3.6			
COM Off Capacitance	C _{COM(OFF)}	f = 1MHz, V _{EN} = V _{COM} = 0V		PS398		31		
				PS399		14		
COM Off Capacitance	C _{COM(ON)}	f = 1MHz, V _{COM} = 0V	PS398		35			
			PS399		20			
Supply								
Power-Supply Range			Full	±3		±8	V	
Positive-Supply Current	I+	V _{EN} = V _A = 0V or V+, V+ = 5.5V, V- = -5.5V		-1		1	μA	
Negative-Supply Current	I-			-1		1		
Ground Current	I _{GND}			-1		1		

Notes:

- Algebraic convention, where the most negative value is a minimum and the most positive is a maximum, is used in this data sheet.
- Typical values are for DESIGN AID ONLY, not guaranteed or subject to production testing.
- Guaranteed by design.
- $\Delta R_{ON} = R_{ONmax} - R_{ONmin}$.
- Flatness is defined as the difference between the maximum and minimum values of on-resistance measured.
- Leakage parameters are 100% tested at maximum rated hot temperature and guaranteed by correlation at +25°C.
- Off Isolation = $20 \log_{10} V_{COM} / V_{NO}$. See Figure 5.

Electrical Specifications - Single 5V Supply ($V_+ = +5V \pm 10\%$, $V_- = 0V$, $GND = 0V$, $V_{AH} = V_{ENH} = +2.4$,
 $V_{AL} = V_{ENL} = +0.8V$)

Parameters	Symbol	Conditions	Temp (°C)	Min ⁽¹⁾	Typ ⁽²⁾	Max ⁽¹⁾	Units	
Analog Switch								
Analog Signal Range ⁽³⁾	V_{COM}, V_{NO}		Full	0		V_+	V	
On-Resistance	R_{ON}	$I_{NO} = 1mA, V_{COM} = 3.5V, V_+ = 4.5V$	25		100	125	ohm	
			Full			280		
R_{ON} Matching Between Channels ⁽⁴⁾	ΔR_{ON}	$I_{NO} = 1mA, V_{COM} = 3.5V, V_+ = 4.5V$	25			11	ohm	
			Full			13		
On-Resistance Flatness	R_{FLAT}	$I_{NO} = 1mA, V_{COM} = 1.5V, 2.5V, 3.5V, V_+ = 5V$	25			18	ohm	
			Full			22		
NO-Off Leakage Current ⁽⁶⁾	$I_{NO(OFF)}$	$I_{NO} = 4.5V, V_{COM} = 0V, V_+ = 5.5V$	25	-0.1		0.1	nA	
			Full	-1.0		1.0		
COM-Off Leakage Current ⁽⁶⁾	$I_{COM(OFF)}$	$V_{COM} = 4.5V, V_{NO} = 0V, V_+ = 5.5V$	PS398	25	-0.2		50	nA
			PS398	Full	-2.5		100	
			PS399	25	-0.2		50	
			PS399	Full	-1.5		100	
COM-On Leakage Current ⁽⁷⁾	$I_{COM(ON)}$	$V_{COM} = 4.5V, V_{NO} = 4.5V, V_+ = 5.5V$	PS398	25	-0.4		0.4	nA
			PS398	Full	-5		5	
			PS399	25	-0.2		0.2	
			PS399	Full	-2.5		2.5	
Digital Logic Input								
Logic High Input Voltage	V_{AH}, V_{ENH}		Full	2.4			V	
Logic Low Input Voltage	V_{AL}, V_{ENL}					0.8		
Input Current with Input Voltage High	I_{AH}, I_{ENH}	$V_A = V_{EN} = 2.4V$		-0.1		0.1	μA	
Input Current with Input Voltage Low	I_{AL}, I_{ENL}	$V_A = V_{EN} = 0.8V$		-0.1		0.1		
Supply								
Power-Supply Range	V_+		Full	3		15	V	
Positive-Supply Current	I_+	$V_{EN} = V_+ \text{ or } 0V, V_A = 0V, V_+ = 5.5V, V_- = 0V$		-1.0		1.0	μA	
Negative-Supply Current	I_-			-1.0		1.0		
Ground Current	I_{GND}			-1.0		1.0		

Dynamic							
Transition Time	t _{TRANS}	V _{NO} = 3V	25	10	72	245	ns
Break-Before-Make Time Delay	t _{OPEN}				36		
Enable Turn-On Time	t _{ON(EN)}				110	200	
Enable Turn-Off Time	t _{OFF(EN)}	25	65	125			
			Full			275	
			Full			200	
Charge Injection ⁽³⁾	Q	C _L = 1nF, V _S = 0V, R _S = 0Ohm,	25		2.8	5	pC

Electrical Specifications - Single 3V Supply (V₊ = + 5V ± 10%, V₋ = 0V, GND = 0V, V_{AH} = V_{ENH} = +2.4, V_{AL} = V_{ENL} = +0.8V)

Parameters	Symbol	Conditions	Temp (°C)	Min ⁽¹⁾	Typ ⁽²⁾	Max ⁽¹⁾	Units
Switch							
Analog Signal Range ⁽³⁾	V _{COM} , V _{NO}		Full	0		V ₊	V
On-Resistance	R _{ON}	I _{NO} = 1mA, V _{COM} = 1.5V, V ₊ = 3V	25		160	375	ohm
			Full			425	
Dynamic							
Transition Time ⁽³⁾	t _{TRANS}	Figure 1, V _{IN} = 2.4V V _{NO1} = 1.5V, V _{NO8} = 0V	25		200	575	ns
Enable Turn-On Time	t _{ON(EN)}	Figure 2, V _{INH} = 2.4V V _{INL} = 0V, V _{NO1} = 1.5V			200	500	
Enable Turn-Off Time	t _{OFF(EN)}	Figure 2, V _{INH} = 2.4V V _{INL} = 0V, V _{NO1} = 1.5V			92	400	
Charge Injection ⁽³⁾	Q	C _L = 1nF, V _S = 0V, R _S = 0Ohm,			2	5	pC

Notes:

- Algebraic convention, where the most negative value is a minimum and the most positive is a maximum, is used in this data sheet.
- Typical values are for DESIGN AID ONLY, not guaranteed or subject to production testing.
- Guaranteed by design.
- $\Delta R_{ON} = R_{ONmax} - R_{ONmin}$.
- Flatness is defined as the difference between the maximum and minimum values of on-resistance measured.
- Leakage parameters are 100% tested at maximum rated hot temperature and guaranteed by correlation at +25°C.
- Worst-case isolation is on channel 4 because of its proximity to the COM pin. Off isolation = $20\log V_{COM}/V_{NO}$, V_{COM} = output, V_{NO} = input to off switch
- Off Isolation = $20\log_{10} V_{COM} / V_{NO}$. See Figure 5.

Electrical Specifications - Single +3.3V Supply ($V_+ = 3.3V \pm 10\%$, $GND = 0V$, $V_{INH} = 2.4V$, $V_{INL} = 0.8V$)

Parameters	Symbol	Conditions	Temp (°C)	Min ⁽¹⁾	Typ ⁽²⁾	Max ⁽¹⁾	Units
Analog Switch							
Analog Signal Range ⁽³⁾	V_{ANALOG}			0		V_+	V
On-Resistance	R_{ON}	$V_+ = 3V$, $I_{COM} = 1mA$ V_{NO} or $V_{NC} = 1.5V$	25		40	70	ohm
			Full		50	80	
Dynamic							
Turn-On Time ⁽³⁾	t_{ON}	V_{NO} or $V_{NC} = 1.5V$, Figure 2	25		50	125	ns
			Full		100	250	
Turn-Off Time ⁽³⁾	t_{OFF}		25		30	75	
			Full		60	150	
Charge Injection ⁽³⁾	Q	$C_L = 1nF$, $V_{GEN} = 0V$, $R_{GEN} = 0\text{-ohm}$, Figure 4	25		1	5	pC
Supply							
Positive Supply Current	I_+	$V_+ = 3.6V$, $V_{IN} = 0V$ or V_+ , all channels on or off	Full	-1	0.01	1	μA

Electrical Specifications - Single +12V Supply ($V_+ = 12V \pm 10\%$, $GND = 0V$, $V_{INH} = 4V$, $V_{INL} = 0.8V$)

Parameters	Symbol	Conditions	Temp (°C)	Min ⁽¹⁾	Typ ⁽²⁾	Max ⁽¹⁾	Units
Analog Switch							
Analog Signal Range ⁽³⁾	V_{ANALOG}			0		V_+	V
On-Resistance	R_{ON}	$V_+ = 10.8V$, $I_{COM} = 1mA$ V_{NO} or $V_{NC} = 110V$	25		15	25	ohm
			Full		20	40	
Dynamic							
Turn-On Time ⁽³⁾	t_{ON}	V_{NO} or $V_{NC} = 1.5V$, Figure 2	25		25	50	ns
			Full		50	100	
Turn-Off Time ⁽³⁾	t_{OFF}		25		20	40	
			Full		40	75	
Charge Injection ⁽³⁾	Q	$C_L = 1nF$, $V_{GEN} = 0V$, $R_{GEN} = 0\text{-ohm}$, Figure 4	25		1	5	pC
Supply							
Positive Supply Current	I_+	$V_+ = 13V$, $V_{IN} = 0V$ or V_+ , all channels on or off	Full	-1	0.01	1	μA

Test Circuits/Timing Diagrams

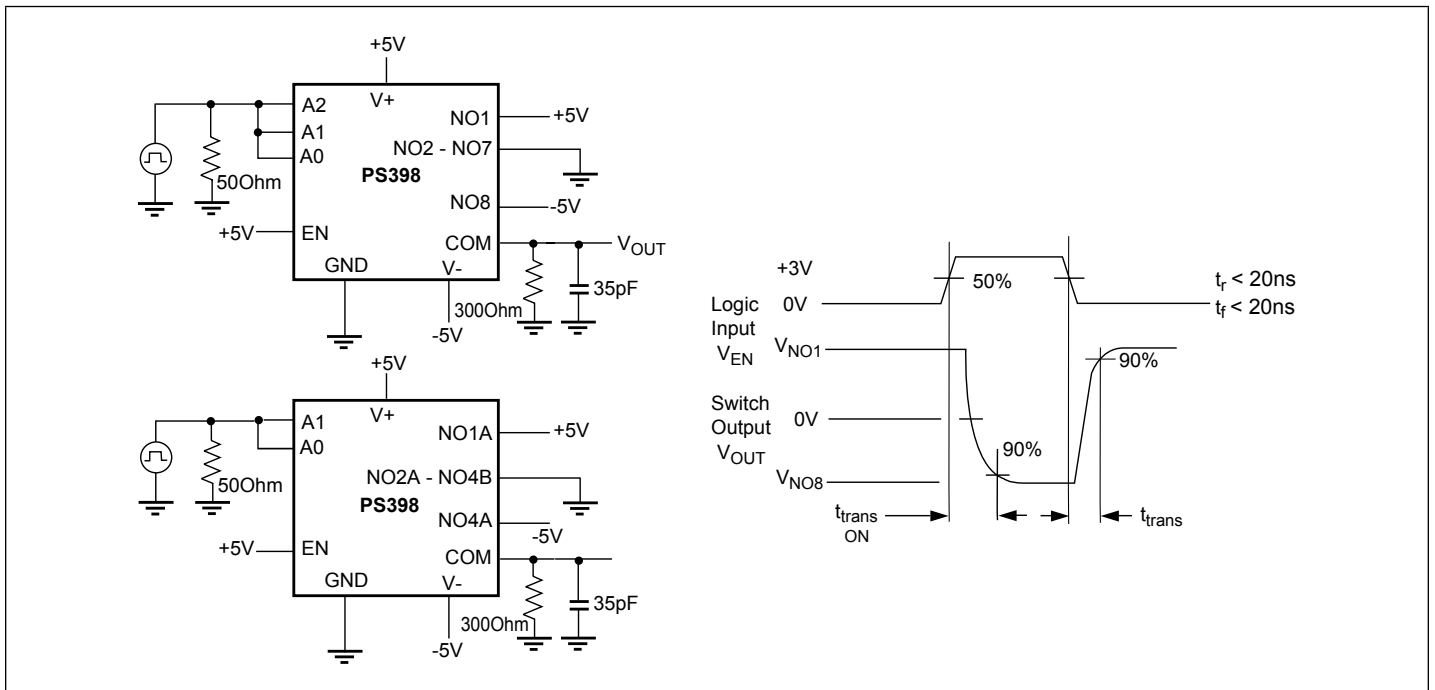

Figure 1. Transition Time

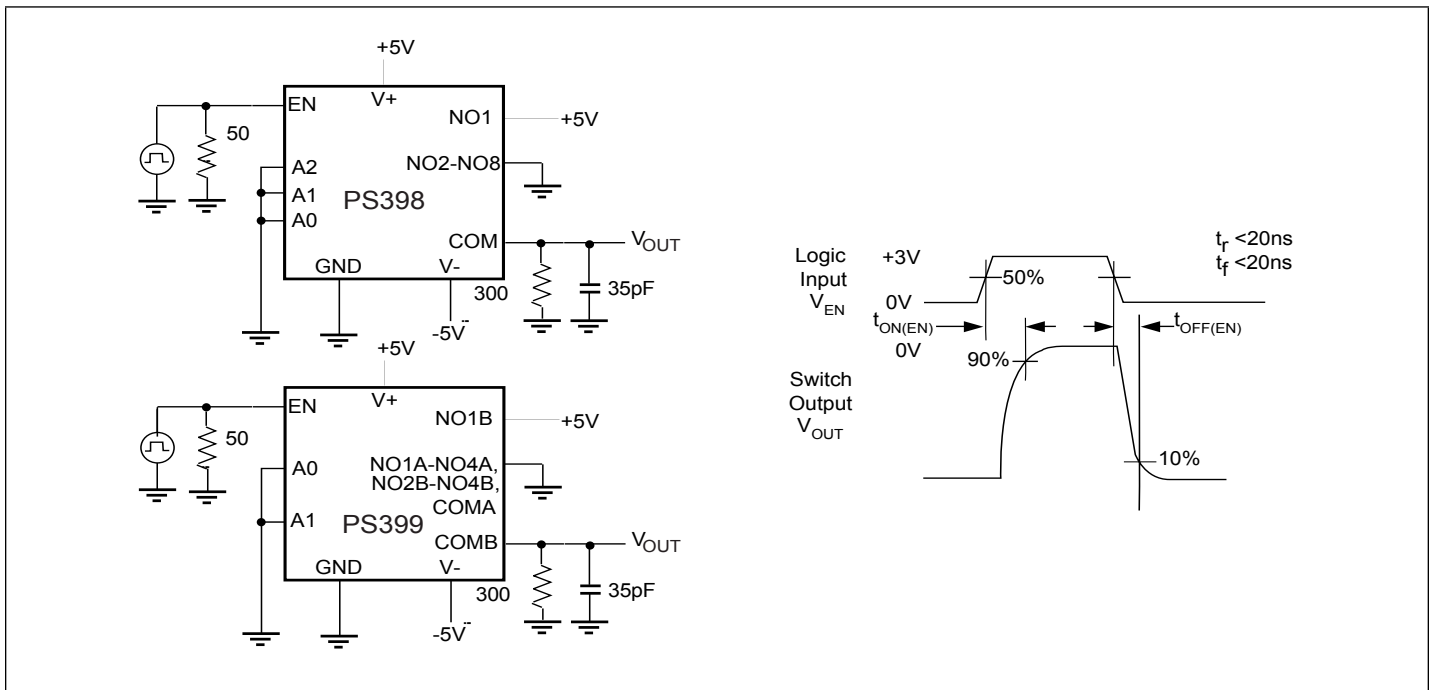

Figure 2. Enable Switching Time

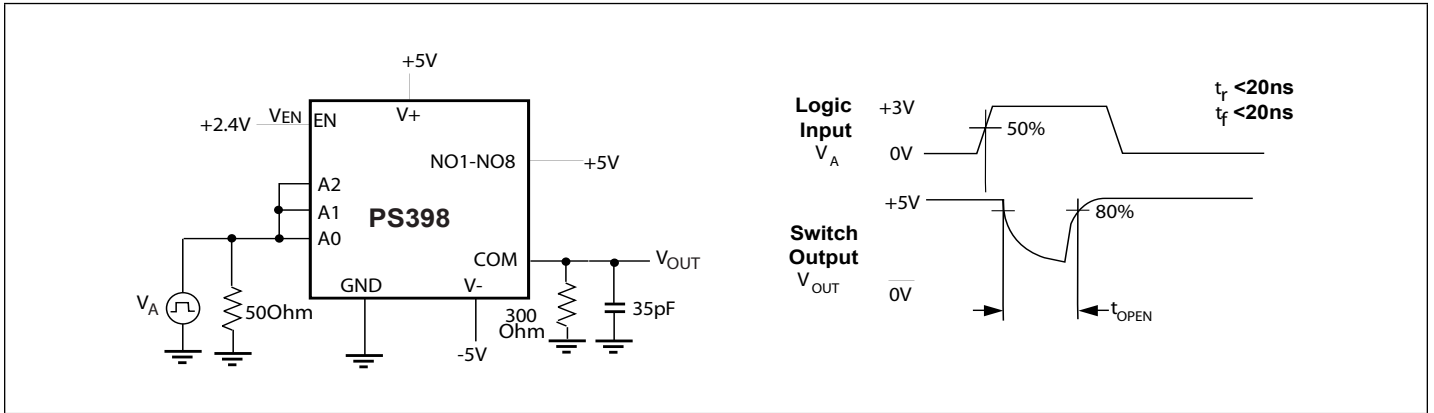

Figure 3. Break-Before-Make Interval

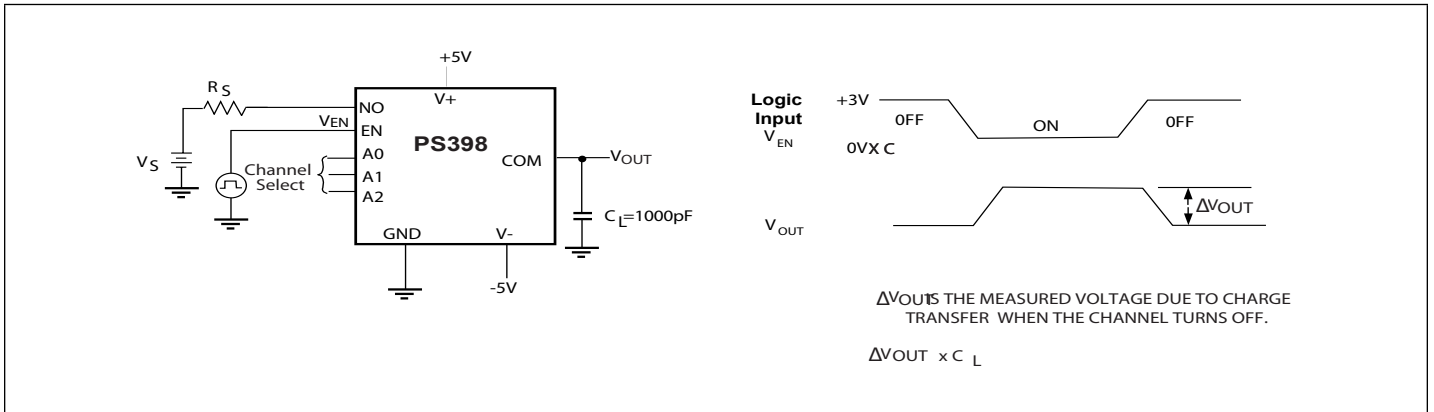

Figure 4. Charge Injection

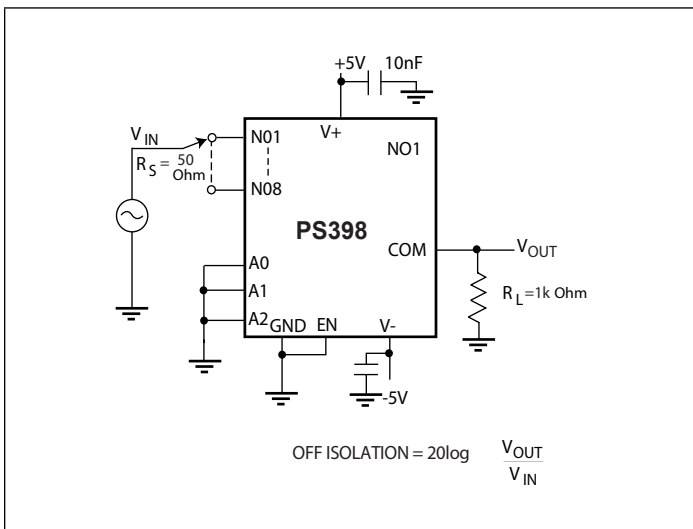

Figure 5. Off Isolation

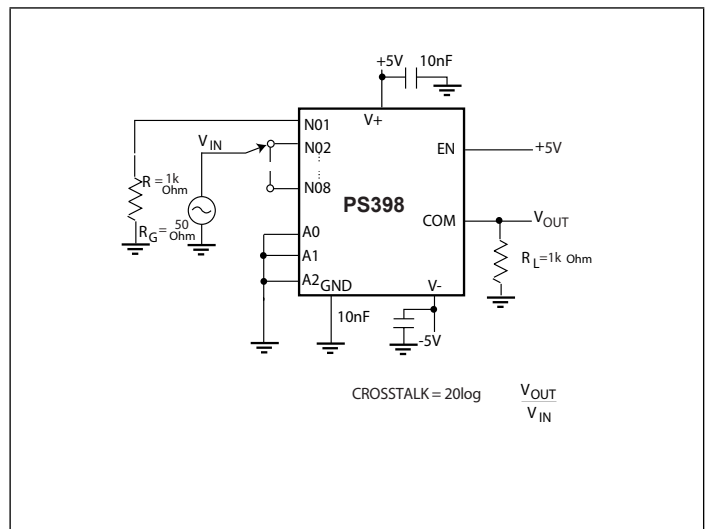

Figure 6. CrossTalk

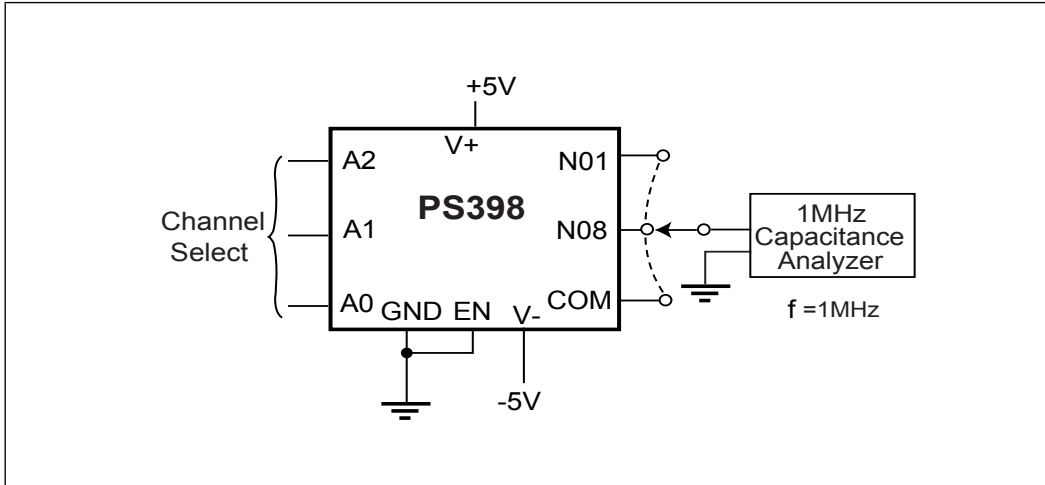

Figure 8. NO/COM Capacitance

Application Information

Overvoltage Protection

Proper power-supply sequencing is recommended for all CMOS devices. Do not exceed the absolute maximum ratings, because stresses beyond the listed ratings may cause permanent damage to the devices. Always sequence V+ on first, followed by V-, and then logic inputs. If power-supply sequencing is not possible, add two small signal diodes or two current limiting resistors in series with the supply pins for overvoltage protection (Figure 9). Adding diodes reduces the analog signal range, but low switch resistance and low leakage characteristics are unaffected.

Maximum Sampling Rate

From the sampling theorem, the sampling frequency needed to properly recover the original signal should be more than twice its maximum component frequency. In real applications, sampling at three or four times the maximum signal frequency is customary.

The maximum sampling rate of a multiplexer is determined by its transition time (t_{TRANS}), the number of channels being multiplexed, and the settling time ($t_{SETTLING}$) of the sampled signal at the output. The maximum sampling rate is:

$$f_s = \frac{1}{n(t_{TRANS} + t_{SETTLING})} \quad (1)$$

Where n = number of channels scanned: 8 for PS398, 4 for PS399. t_{TRANS} is given on the specification table: 150 ns max.

Settling time is the time needed for the output to stabilize within the desired accuracy band of +1 LSB (least significant bit).

Other factors determining settling time are: signal source impedance, capacitive load at the output. Figure 10 illustrates the steady state model. To figure out what the settling time due to the multiplexer is, we can assume that $R_S = 0\Omega$, and $C_L = 0$. In real life, the effects of R_S and C_L should be taken into account when performing these calculations.

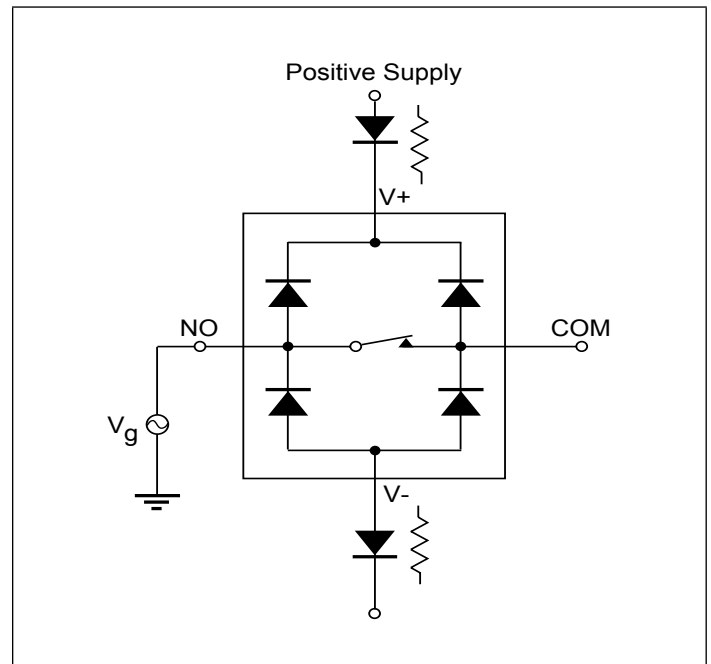

Figure 9. Overvoltage protection is accomplished using two external blocking diodes or two current limiting resistors.

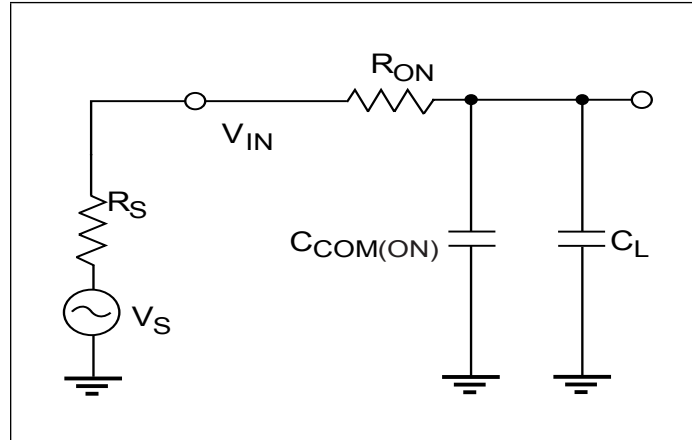

Figure 10. Equivalent model of one multiplexer channel

The table below shows how many time constants ($m\tau$) are needed to reach an accuracy of one LSB. $\tau = R_{ON} \times C_{COM(ON)}$

Bits	Accuracy (%)	m
8	0.25	6
12	0.012	9
15	0.0017	11

Now, let's calculate what the maximum sampling rate for the PS398. Assume a 12-bit accuracy and room temperature operation.

In equation (1) above, $n = 8$, $t_{TRANS} = 150ns$, $t_{SETTLING} = 9\tau$, $\tau = 100ohm \times 54pF$

$$f_s = \frac{1}{8 [150ns + 9(100ohm \times 54pF)]}$$

or $f_s = 630kHz$.

Assuming a x4 oversampling rate, the maximum sampling speed for the PS398 would be $630 \div 4 = 157kHz$.

Packaging Mechanical: 16-Pin SOIC (W)

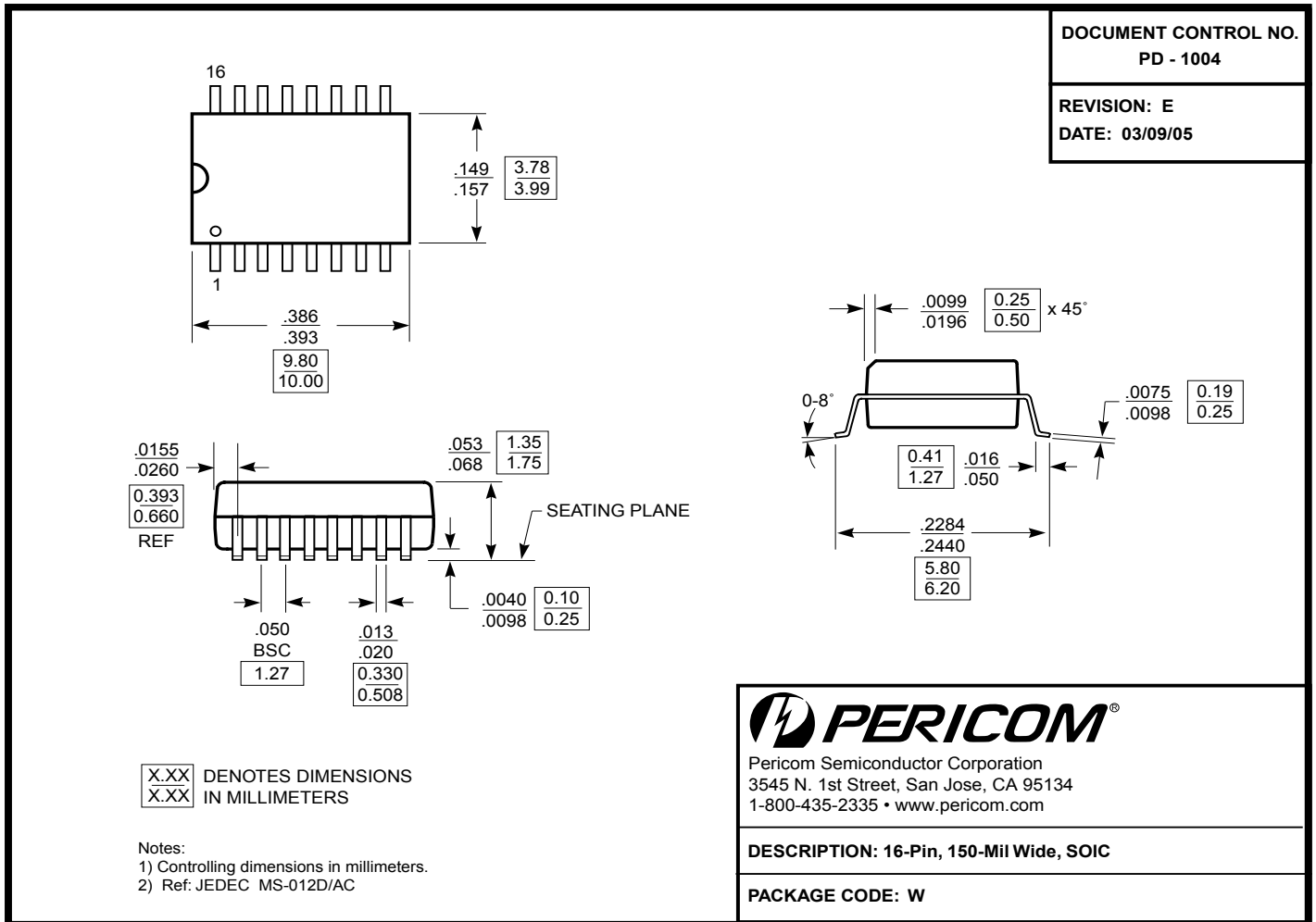

Ordering Information

Ordering Code	Package Code	Package Type
PS398CSEE	W	Pb-free & Green, 16-pin SOIC

1. Thermal characteristics can be found on the company web site at www.pericom.com/packaging/