

Tektronix®

DC POWER SUPPLY

PS 501

PS 501-1

PS 501-2

INSTRUCTION MANUAL



**PLEASE CHECK FOR CHANGE INFORMATION
AT THE REAR OF THIS MANUAL**

**DC POWER SUPPLY
PS 501
PS 501-1
PS 501-2**

INSTRUCTION MANUAL

Tektronix, Inc.
P.O. Box 500
Beaverton, Oregon 97077

Serial Number _____

070-100102
Product Group 75

First Printing APR 1972
Revised MAY 1983

Copyright © 1972, 1980 Tektronix, Inc. All rights reserved.
Contents of this publication may not be reproduced in any
form without the written permission of Tektronix, Inc.

Products of Tektronix, Inc. and its subsidiaries are covered
by U.S. and foreign patents and/or pending patents.

TEKTRONIX, TEK, SCOPE-MOBILE, and  are
registered trademarks of Tektronix, Inc. TELEQUIPMENT
is a registered trademark of Tektronix U.K. Limited.

Printed in U.S.A. Specifications and price change privileges
are reserved.

INSTRUMENT SERIAL NUMBERS

Each instrument has a serial number on a panel insert, tag,
or stamped on the chassis. The first number or letter
designates the country of manufacture. The last five digits
of the serial number are assigned sequentially and are
unique to each instrument. Those manufactured in the
United States have six unique digits. The country of
manufacture is identified as follows:

- | | |
|---------|---|
| 8000000 | Tektronix, Inc., Beaverton, Oregon, USA |
| 1000000 | Tektronix Guernsey, Ltd., Channel Islands |
| 2000000 | Tektronix United Kingdom, Ltd., London |
| 3000000 | Sony/Tektronix, Japan |
| 7000000 | Tektronix Holland, NV, Heerenveen, The Netherlands |

TABLE OF CONTENTS

| | | Page |
|---|---|------|
| LIST OF ILLUSTRATIONS | | ii |
| Section 1 | Specification | 1-11 |
| Section 2 | Operating Instructions | 2-11 |
| <div style="border: 1px solid black; padding: 2px; display: inline-block; margin: 10px 0;">WARNING</div> | | |
| <p><i>THE FOLLOWING SERVICE INSTRUCTIONS ARE FOR USE BY QUALIFIED PERSONNEL ONLY. TO AVOID PERSONAL INJURY, DO NOT PERFORM ANY SERVICING OTHER THAN THAT CONTAINED IN OPERATING INSTRUCTIONS UNLESS YOU ARE QUALIFIED TO DO SO.</i></p> | | |
| Section 3 | Theory of Operation | 3-11 |
| Section 4 | Calibration Procedure | 4-11 |
| | Performance Check | 4-11 |
| | Adjustment Procedure | 4-4 |
| Section 5 | Maintenance | 5-11 |
| Section 6 | Options | 6-11 |
| Section 7 | Replaceable Electrical Parts | 7-11 |
| Section 8 | Diagrams and Illustrations | 8-11 |
| Section 9 | Replaceable Mechanical Parts | 9-11 |

LIST OF ILLUSTRATIONS

| Fig. No. | | Page |
|----------|--|------|
| 2-1 | PS 501 (-1,-2) Installation and Removal | 2-1 |
| 2-2 | Controls and Connectors | 2-3 |
| 2-3 | Controls and Connectors | 2-4 |
| 2-4 | Series-connected supplies | 2-5 |
| 2-5 | Parallel-connected supplies | 2-5 |
| 2-6 | Differential measurement connections | 2-5 |
| 2-7 | Stair-step output characteristics of series and parallel connected supplies .. | 2-5 |
| 2-8 | Multiple load connections | 2-6 |
| 2-9 | Monitor Connections | 2-6 |
| 2-10 | Ground-loop current caused by remote grounded load | 2-7 |
| 2-11 | Reverse-current shunt, (Rs) with active load | 2-7 |
| 3-1 | Simplified diagram of PS 501 (-1,-2) | 3-1 |
| 3-2 | Operating characteristics with varying currents, voltages, and loads | 3-2 |
| 5-1 | Semiconductor device lead configurations found in the T1M 500 family ... | 5-5 |
| 5-2 | Color code for resistors and capacitors | 5-6 |

OPERATORS SAFETY SUMMARY

The general safety information in this part of the summary is for both operating and servicing personnel. Specific warnings and cautions will be found throughout the manual where they apply, but may not appear in this summary.

Terms In This Manual

CAUTION statements identify conditions or practices that could result in damage to the equipment or other property.

WARNING statements identify conditions or practices that could result in personal injury or loss of life.

Terms As Marked on Equipment

CAUTION indicates a personal injury hazard not immediately accessible as one reads the marking, or a hazard to property including the equipment itself.

DANGER indicates a personal injury hazard immediately accessible as one reads the marking.

Symbols In This Manual



This symbol indicates where applicable cautionary or other information is to be found.

Symbols As Marked on Equipment



DANGER High voltage.



Protective ground (earth) terminal.



ATTENTION Refer to manual.

Power Source

This product is intended to operate from a power source that will not apply more than 250 volts rms between the supply conductors or between either supply conductor and ground. A protective ground connection by way of the grounding conductor in the power cord is essential for safe operation.

Grounding the Product

This product is grounded through the grounding conductor of the power cord. To avoid electrical shock, plug the power cord into a properly wired receptacle before connecting to the product input or output terminals. A protective ground connection by way of the grounding conductor in the power cord is essential for safe operation.

Danger Arising From Loss of Ground

Upon loss of the protective ground connection, all accessible conductive parts (including knobs and controls that may appear to be insulating) can render an electric shock.

Use the Proper Power Cord

Use only the power cord and connector specified for your product.

Use only a power cord that is in good condition.

For detailed information on power cords and connectors, see maintenance section.

Refer cord and connector changes to qualified service personnel.

Use the Proper Fuse

To avoid fire hazard, use only the fuse of correct type, voltage rating and current rating as specified in the parts list for your product.

Refer fuse replacement to qualified service personnel.

Do Not Operate in Explosive Atmospheres

To avoid explosion, do not operate this product in an explosive atmosphere unless it has been specifically certified for such operation.

Do Not Remove Covers or Panels

To avoid personal injury, do not remove the product covers or panels. Do not operate the product without the covers and panels properly installed.

SERVICE SAFETY SUMMARY

FOR QUALIFIED SERVICE PERSONNEL ONLY

Refer also to the preceding Operators Safety Summary.

Do Not Service Alone

Do not perform internal service or adjustment of this product unless another person capable of rendering first aid and resuscitation is present.

Use Care When Servicing With Power On

Dangerous voltages exist at several points in this product. To avoid personal injury, do not touch exposed connections and components while power is on.

Disconnect power before removing protective panels, soldering, or replacing components.

Power Source

This product is intended to operate from a power source that will not apply more than 250 volts rms between the supply conductors or between either supply conductor and ground. A protective ground connection by way of the grounding conductor in the power cord is essential for safe operation.

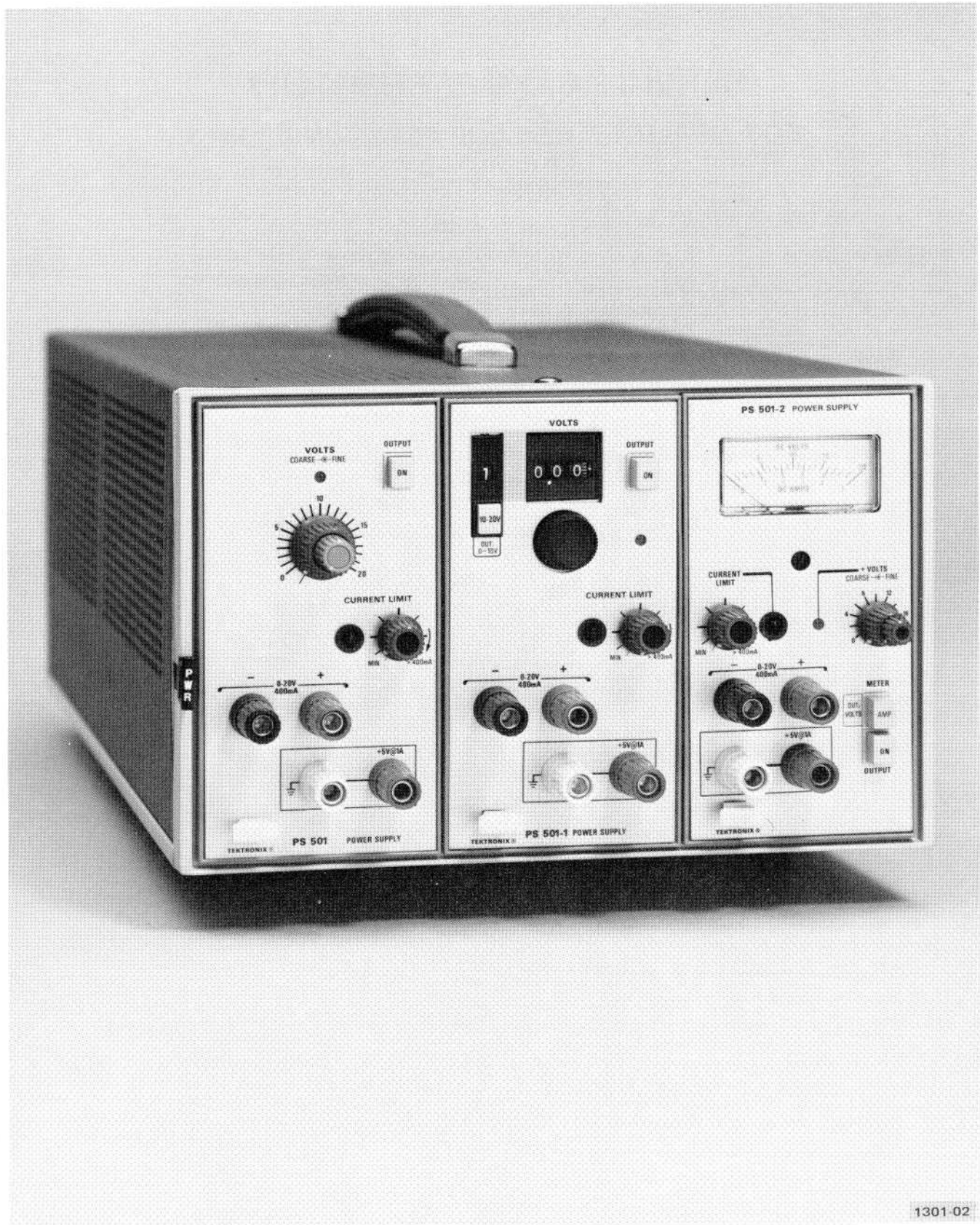

1301-02

PS 501 (-1, -2) Power Supplies.

SPECIFICATION

Introduction

The PS 501 is a constant-voltage, current-limiting, 0 to 20 Vdc power supply designed to operate in any compartment of a TM/500 Series Power Module. The PS 501 is a floating power supply in which either terminal may be grounded, or floated to 350 Vdc peak ac. Front-panel controls provide continuously variable voltage selection, as well as current limiting from 0 to at least 400 mA.

The floating supply is suited for powering discrete transistor circuitry, or acting as a bias or reference supply. Several PS 501's or other suitable supplies can be combined for applications involving complementary circuitry, linear integrated circuits, or any circuitry requiring cascaded DC levels.

A ground-referenced ± 5 V auxiliary supply is also included that is suitable for bipolar logic, light-emitting diodes, incandescent displays and similar applications. With the floating supply available for powering discrete interface circuits and level shifting, the PS 501 can be used for many digital/analog applications.

NOTE

Instrument differences between the PS 501-2 and the PS 501 (-1) are listed in this manual at various places. Where no differences are indicated, the PS 501 information applies to the PS 501-2.

The electrical characteristics in this specification are valid with the following conditions:

1. The instrument must have been adjusted at an ambient temperature between $+20^{\circ}\text{C}$ and $+30^{\circ}\text{C}$.
2. The instrument must be in a non-condensing environment whose limits are described under Environmental.
3. Allow twenty minutes warm-up time for operation to specified accuracy, sixty minutes after exposure to or storage in a high humidity (condensing) environment.

The electrical and environmental performance limits together with their related validation procedures comprise a complete statement of the electrical and environmental performance of a calibrated instrument.

SUPPLEMENTAL INFORMATION ON

The supplemental information listed here represents limits that ensure optimum instrument operation. They are not instrument specifications, but are intended to be used only as maintenance or operational aids.

Table 1-1

ELECTRICAL CHARACTERISTICS

| Characteristics | Performance Requirements | Supplemental Information |
|---|--|---|
| 20 Volt Floating Supply | | |
| Voltage Range | 0 V to at least 20 V | 19.99 V in PS 501-1. |
| Rated Output Current | | 400 mA, 0°C to +30°C, derating linearly, to 300 mA at +50°C |
| Overload Protection | | Automatic current limiting and over-temperature shutdown, continuous operation at rated output current at low voltages may actuate a Power Module thermal cutout. NOTE <i>Ripple and noise increase unpredictably when current is being limited.</i> |
| Current Limit Range | ≤10 mA to at least 400 mA | Current limiting is indicated by front panel LED |
| Maximum Floating Voltage | | 350 Vdc + peak ac. |
| Display Accuracy | | |
| PS 501-1 | ± (0.5% of reading ± 10 mV) | Digital dial readout. |
| PS 501-2 | ± 0.4 V. | Analog meter readout. |
| Resolution (Stability) | | |
| PS 501-1 | | Typically 1.6 mV/determined by a 10-turn potentiometer. |
| PS 501-2 | | Typically 10 mV |
| Load Effect (Regulation) | ±1 mV for a 400 mA load change measured at output terminals. | |
| Source Effect (Line Regulation) | ±5 mV for a ±10% line voltage change | |
| Stability | | Typically less than 0.1% ± 5 mV for 8 hours at constant line, load, and temperature |
| Temperature Coefficient | | Typically less than (0.01% ± 0.1 mV) 1°C |
| PAR (Ripple & Noise) (Periodic and Random Deviations) | ≤0.5 mV peak-to-peak with 400 mA load. | 10 Hz to 5 MHz, supply not in current limiting. |
| Transient Recovery Time | | 20 ps or less to recover within 20 mV of final output voltage after a 400 mA change in output current. |

Table 1-1 (cont)

| Characteristics | Performance Requirements | Supplemental Information |
|--|---|---|
| 5 V Supply | | |
| Output Voltage | ± 4.75 V to ± 5.25 ground referenced. | LM309 5 V regulator integrated circuit. |
| Rated Output Current | | 1 A |
| Current Limit | | Non-adjustable and typically 1.5 A to 3 A |
| Load Effect (Regulation) | ± 100 mV for a 1 A load change | |
| Source Effect (Line Regulation) | ± 50 mV for a 10% line voltage change | |
| Stability | | Typically less than 30 mV (0.5%) for 8 hours at constant line, load, and temperature |
| Temperature Coefficient | | Typically less than 0.5 mV/°C |
| PARP (Ripple & Noise) | ≤ 5 mV peak-to-peak with 1 A load. | 10 Hz to 5 MHz, supply not in current limiting. |
| Rear Interface Inputs/Outputs^a | | |
| 20 V Floating Supply | | Pins 22A(+), 21A(-). Same as front panel output terminals. |
| Remote Sense | | Pin 23A |
| Reference Common | | Pins 24A, 24B |
| Current Monitor | | Pins 19B, 22A Voltage is 2 Ω times the actual output current, $\pm 5\%$. Pin 22A is same as + output. Pin 19B is same as emitter of NPN series pass transistor. |
| Slaving Connections | | Pin 26B for current limit slaving. Pin 25B for voltage slaving. |

^a Warning: Floating potentials will appear superimposed on all rear interface inputs and outputs.

Table 1-2
ENVIRONMENTAL CHARACTERISTICS

| Characteristics | Information |
|-----------------------------|--|
| Temperature | |
| Operating | 0° C to 30° C (with derating to 50° C) |
| Storage | -40° C to +75° C |
| Altitude | |
| Operating | To 15,000 feet. Maximum operating temperature decreased by 1° C/100 feet from 5000 to 15,000 feet. |
| Storage | To 50,000 feet. |
| Vibration | |
| Operating and non-operating | With the instrument complete, vibration frequency swept from 10 to 55 to 10 Hz at 1 minute per sweep. Vibrate 15 minutes in each of the three major axes at 0.015 inch total displacement. Hold 10 minutes at any major resonance or, if none, at 55 Hz. Total time, 75 minutes. |
| Shock | |
| Operating and non-operating | 30 g, 1/2 sine, 11 ms duration, 3 shocks in each direction along 3 major axes, for a total of 18 shocks. |
| Transportation | Qualified under National Safe Transit Committee Test Procedure 1A, Category II. |

Table 1-3
PHYSICAL CHARACTERISTICS

| Characteristics | Dimensions |
|--|-------------------|
| Overall Size (measured at maximum points) | |
| Height | 4.96 in (126 mm) |
| Width | 2.6 in (66.8 mm) |
| Length | 11.65 in (296 mm) |
| Net Weight (Instrument only) | 2 lbs (0.906 kg) |

OPERATING INSTRUCTIONS

PREPARATION

The PS 501 (-1) (-2) is calibrated and ready for use when received. It is designed to operate in any compartment of a TM/500 Series Power Module. Refer to the Power Module Instruction Manual for line voltage requirements.

To install the PS 501 (-1) (-2), align the upper and lower rails of the plug-in with the Power Module tracks and insert until the plug-in panel is flush with the Power Module panel (see Fig. 2-1). To remove, pull the release latch to disengage the PS 501 (-1) (-2) from the Power Module.

CAUTION

Turn the Power Module off before inserting the plug-in; otherwise, damage may occur to the plug-in circuitry.

The following procedure is intended to prepare the instrument for immediate use and demonstrate the basic function of the unit. Operation of the Power Module and other plug-ins in this system are described in their respective instruction manuals. Functions of front-panel controls, indicators and connectors are described in Fig. 2-2 and Fig. 2-3.

NOTE

Before using the PS 501 (-1) (-2) read the Operating Considerations in this section regarding proper techniques for connecting various loads, etc.

The presence of output voltage is verified by a voltage indicator light on the front panel. The brightness of this light varies with output voltage.

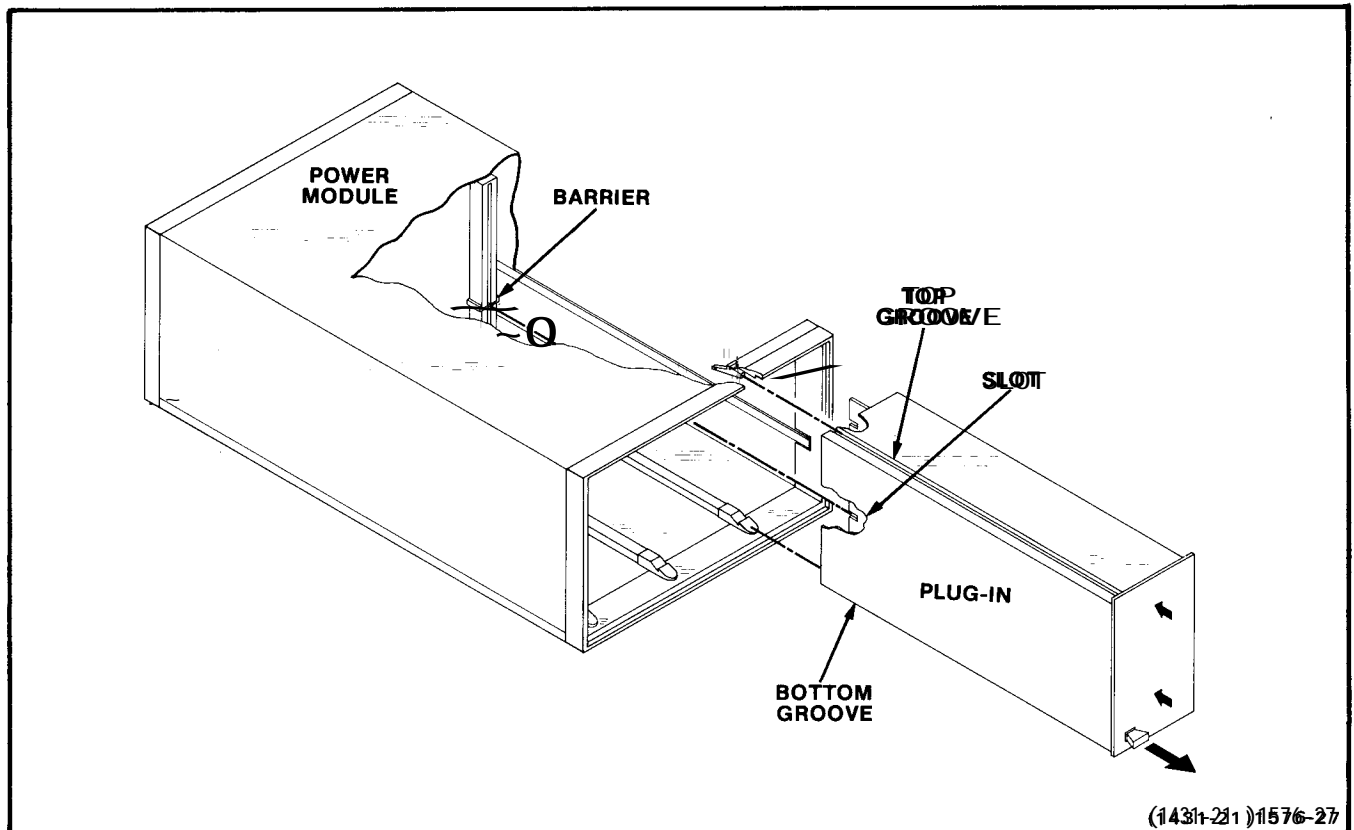

Fig. 2-1. PS 501 (-1, -2) Installation and removal.

Operating Instructions—PS 501 (-1, -2)

A panel-mounted, light-emitting diode lights when the PS 501 goes into current-limiting. This is a very sensitive indicator that starts to glow before hard limiting occurs. Hard limiting is indicated by maximum brightness of the light-emitting diode as well as a dimming of the voltage indicator light. These functions are easily evaluated by momentarily shorting the output of the supply.

PS 501-1 is identical to the PS 501 except that the output voltage is selected by a 10-turn precision potentiometer with a 3-digit in-line dial and a range pushbutton. The turns-counting dial allows the output of the PS 501-1 to be set accurately without an expensive external meter. The dial provides accuracy equivalent to that obtained with a 3 1/2 digit DMM.

The PS 501-2 is identical to the PS 501 except that a front-panel meter is provided to aid in accurately setting the output current or voltage of the PS 501-2. See Figs. 2-2 and 2-3, Controls and Connectors.

Constant Voltage/Current Limited Output

1. Press the OUTPUT button to apply power to the plug-in. Observe that the VOLTS indicator light comes on (the light will be very dim at low voltages).
2. Adjust the VOLTS control for approximately 2 V.

NOTE

The use of an external meter is not required for the PS 501-2. The PS 501-2 internal meter can perform the function described in step 3.

3. Set the CURRENT LIMIT control fully *ccw* (to protect the ammeter). Connect an ammeter across the + and - terminals and adjust the CURRENT LIMIT control for the maximum desired current output.

4. Remove the ammeter, connect the load to the + and - terminals and adjust the VOLTS control for the desired output.

Series Operation

The outputs of two or more supplies can be connected in series as shown in Fig. 2-4 to obtain an output voltage equal to the sum of the output voltages from each supply. The maximum output is limited to 350 Vdc ± peak ac (i.e., the isolation voltage rating between the output terminals and ground). Each supply must be adjusted individually to obtain the desired output voltage.

NOTE

The PS 501 (-1) (-2) has internal diodes connected across the output to protect any of the series-connected supplies against reverse polarity if the load is shorted, or one of the supplies is not on.

Parallel Operation

The outputs of two or more current-limiting, automatic-crossover supplies can be connected in parallel as shown in Fig. 2-5 to obtain an output current equal to the sum of the output currents from each supply. Each supply must be adjusted individually to obtain the desired output current.

One supply should be set for the desired output voltage and the other should be set for a slightly higher voltage. The supply set for the desired voltage will then become a constant voltage source, while the supply with the higher voltage output becomes a current-limited source (due to automatic crossover) which results in their output voltage decreasing to that of the supply with the lowest output voltage.

APPLICATIONS

Differential Voltage Measurements

Very small dc voltage changes or unknown voltages can be measured by connecting the PS 501-1, a null detector, and the source under test in a differential configuration as shown in Fig. 2-6. Inexpensive comparison measurements nearly the accuracy and sensitivity of costly differential voltmeters can be made with the PS 501-1. The ultimate accuracy and sensitivity of the measurement depend on the PS 501-1 and the type of null detector used. A calibrated dc amplifier in a high gain oscilloscope such as the TEKTRONIX 1500-Series Oscilloscope with a 5A220N Differential Amplifier plug-in will serve as a convenient null detector, or a sensitive milliammeter with a series resistor is also satisfactory.

NOTE

Examine the circuit for ground loops when using a null detector with one input terminal grounded (see Grounded and Floating Operation).

Series- and Parallel Connected Stair-Step Operation

Series- and parallel-connected PS 501 (-1) (-2)s can be operated to provide a "stair-step" output characteristic by choosing proper load limits and control settings. For example, Fig. 2-7 shows the stair-step output from two series-connected supplies. With each supply set for

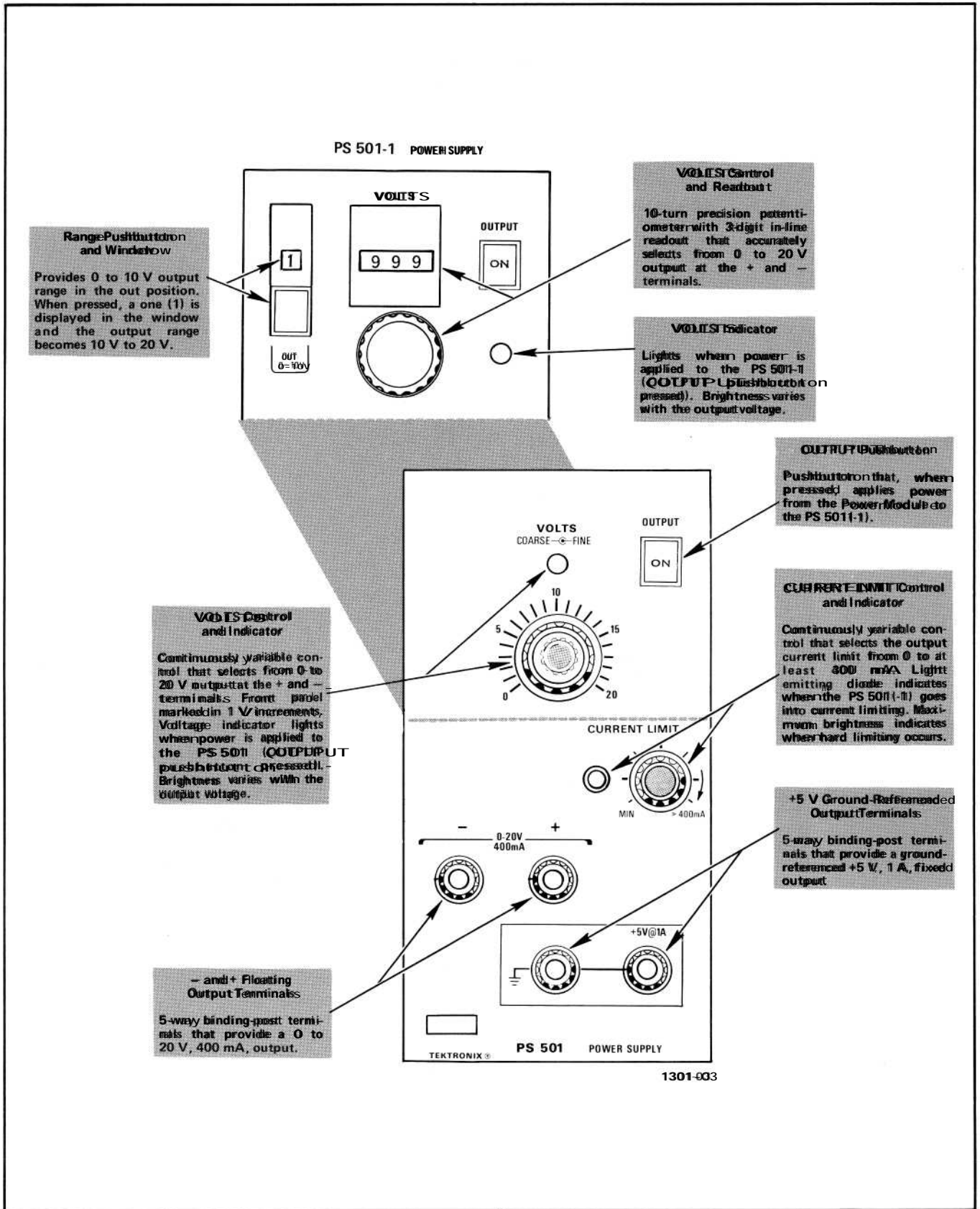

Fig. 2-22. Controls and Connectors.

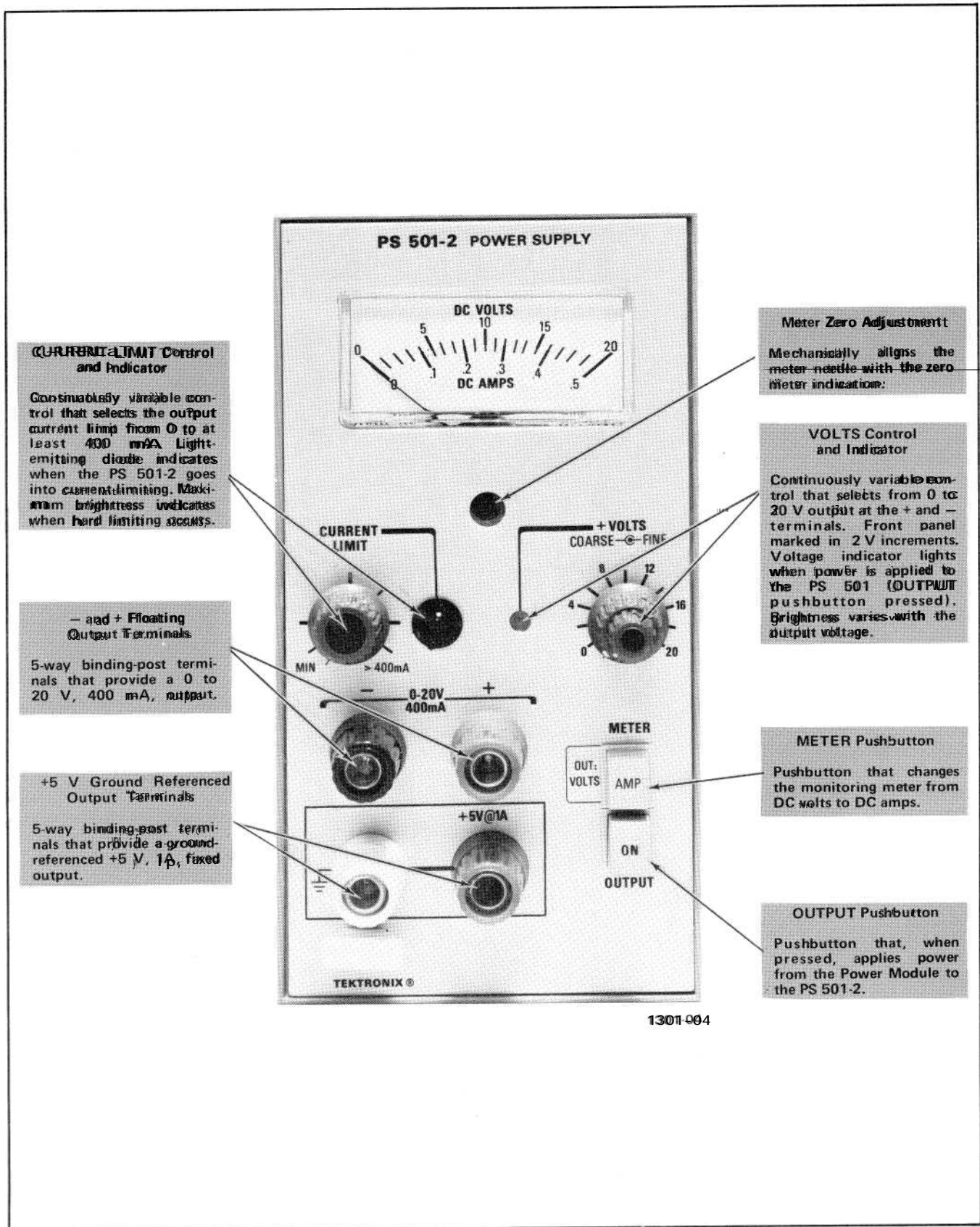

Fig. 2-3. Controls and Connectors.

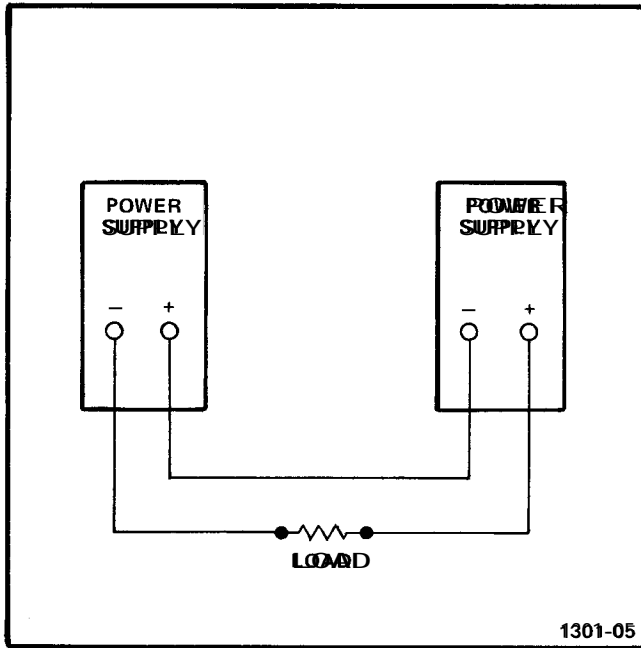

Fig. 2-4. Series-connected supplies.

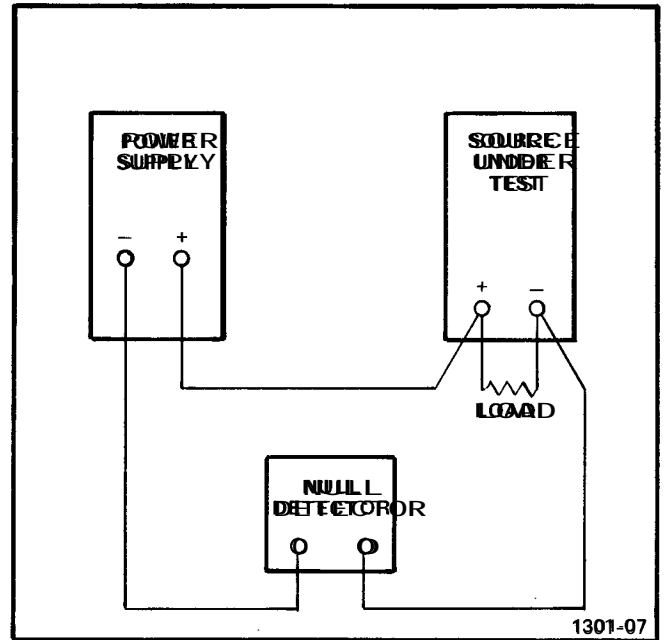

Fig. 2-6. Differential measurement connections.

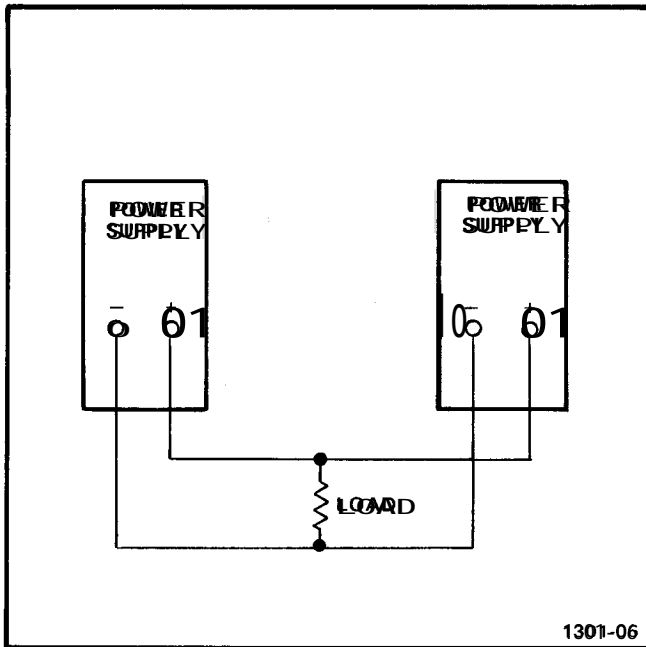

Fig. 2-5. Parallel-connected supplies.

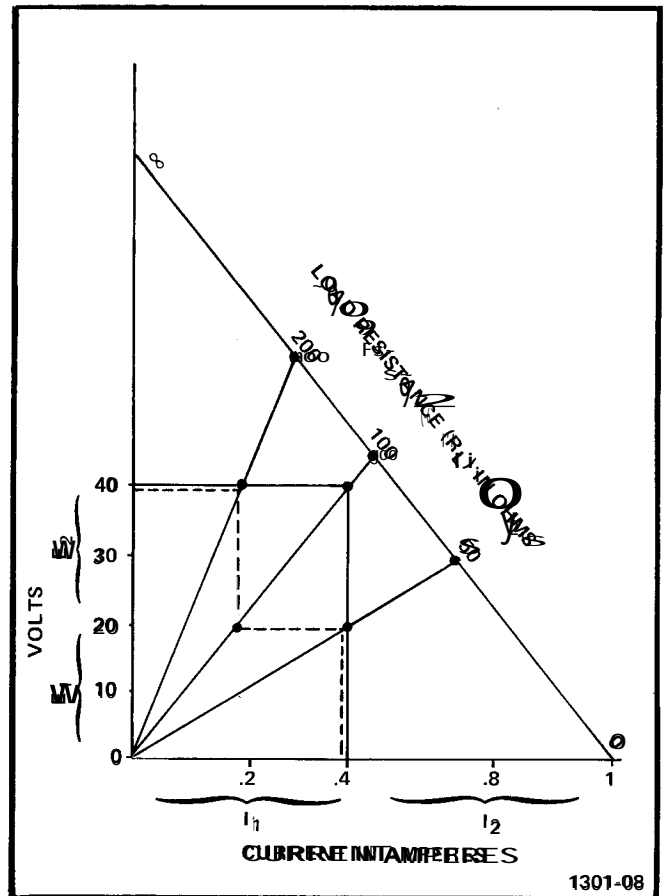

Fig. 2-7. Stair-step output characteristics of series and parallel connected supplies.

Operating Instructions—PS 501 (-1, -2)

maximum voltage and current (20 V, 400 mA) the output voltage remains constant from open-circuit (∞) until the load reaches approximately 100Ω (as illustrated by the solid line in Fig. 2-7). At this crossover point the output voltage decreases with the load and the output current is limited at 400 mA. Therefore, with resistances below approximately 100Ω , both supplies act as current sources with output voltage variable with the load. Since both supplies are set for the same output voltage, each supply shares equally in the power output (I^2R). If one supply is set for a lower output voltage than the other, output power is shared at the same ratio as the output voltage.

Now, by setting supply E_2 for a current limit of 200 mA and varying the load over the same range, the supplies act as constant voltage sources until the load reaches approximately 200Ω . At that crossover point, the supply set for 200 mA (E_2) becomes a current source and its output voltage decreases with the load (as illustrated by the dotted line in Fig. 2-7). At approximately 100Ω and 20 V, supply E_2 no longer contributes to the power output. Subsequently, supply E_1 supplies all the output power and operates as a constant voltage source with output current variable with the load. Then, at approximately 50Ω , supply E_1 crosses over and becomes a current source at its maximum output of 400 mA. Thus, by choosing the appropriate load limits and control settings, any of the four operating characteristics is possible.

Parallel-connected supplies exhibit the same "stair-step" characteristic as in series-connected operation. However, the maximum voltage available is the highest setting of either supply while the maximum current is $I_1 + I_2$.

OPERATING CONSIDERATIONS

Overheating

The PS 501 (-1) (-2) is designed to operate at an ambient temperature from 0°C to $+50^\circ\text{C}$. However, when operating several power supplies in a multi-plug-in Power Module, especially at low output voltages, or when operating close to other heat-producing equipment, internal temperature may exceed safe limits and actuate a thermal cutoff. Refer to the Power Module Instruction Manual for more complete information.

Load and Monitor Connections

Improper connections between the power supply output and the load(s) and/or monitoring device(s) are a common cause of errors. Multiple loads must be connected with separate pairs of leads as shown in Fig. 2-8. Monitoring devices must also be connected with separate leads as shown in Fig. 2-9. Avoid using clip leads, since their contact resistance can exceed the output impedance of the PS 501 (-1) (-2) and cause significant measurement error.

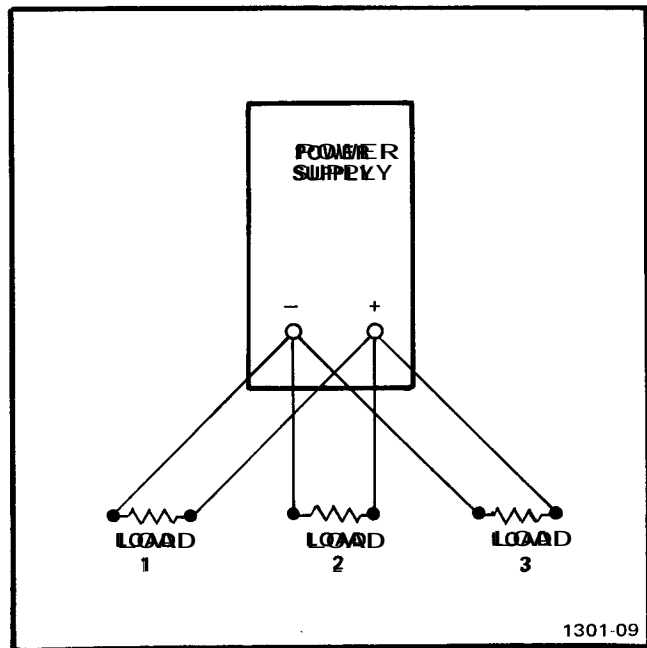

Fig. 2-8. Multiple load connections.

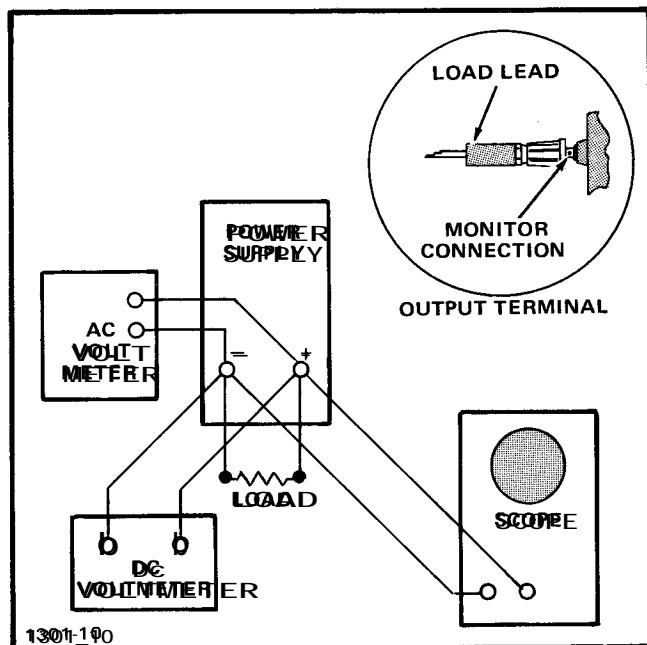

Fig. 2-9. Monitor connections.

Grounded and Floating Operation

The PS 501 (-1) (-2) is a "floating" supply since no internal connections are made to either the chassis or ground. The supply can thus be used as a positive or negative supply by simply grounding the negative or positive output terminal. However, there may be undesirable effects caused by grounding the supply to the

chassis while the load is grounded at some point removed from the supply chassis. For example, if a remote load is connected as shown in Fig. 2-100, ground currents containing the powerline frequency could result and create excessive noise and ripple in series with the load. Thus, floating operation is recommended to insure against problems caused by undesirable ground currents.

Reverse Current Loading

In some bias supply and digital circuitry applications the load might behave as a current source for part of its operating cycle. Since the output circuit of a series regulated supply is unidirectional, current will not pass in the opposite direction except through undesirable paths. The internal reverse current diodes conduct only when the PS 501 (-1) (-2) terminal voltage reverses and

therefore will not work when the voltage is correctly polarized. Connecting a shunt resistor (R_s) as shown in Fig. 2-111 provides an external reverse current path so the power supply sources or delivers current only.

Overvoltage

The PS 501 (-1) (-2) is not protected from overvoltage conditions. Component failure in the PS 501 (-1) (-2) could result in a load damage if external protection is not provided. Likewise, if the load (or other instruments connected to the load) produce a voltage across the PS 501 (-1) (-2) terminals which is the same polarity but of greater amplitude, damage may result depending on the amount of overvoltage and the impedance of the load (source).

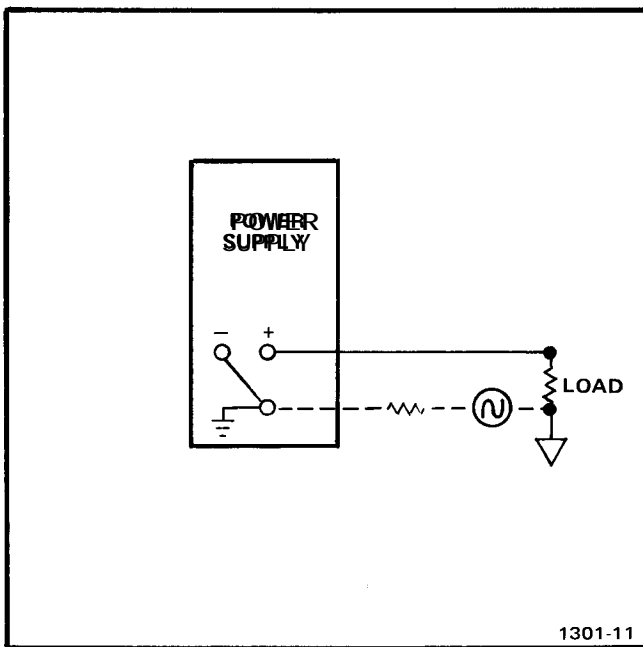

Fig. 2-10. Ground-loop current caused by remote grounded load.

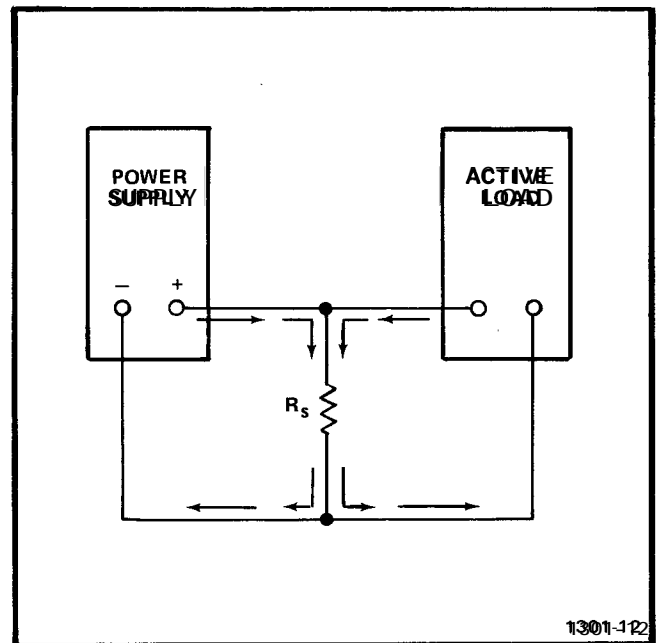

Fig. 2-111. Reverse current shunt (R_s) with active load.

WARNING

THE FOLLOWING SERVICING INSTRUCTIONS ARE FOR USE BY QUALIFIED PERSONNEL ONLY. TO AVOID PERSONAL INJURY, DO NOT PERFORM ANY SERVICING OTHER THAN THAT CONTAINED IN OPERATING INSTRUCTIONS UNLESS YOU ARE QUALIFIED TO DO SO. REFER TO OPERATORS SAFETY SUMMARY AND SERVICE SAFETY SUMMARY PRIOR TO PERFORMING ANY SERVICE.

THEORY OF OPERATION

Introduction

This section contains a discussion of the operating modes of the PS 501, PS 501-1, and PS 501-2 Power Supplies. Circuit operation for obtaining the constant voltage and current limited output with automatic crossover, line and load regulation and 5 V ground-referenced output is described. Refer to the schematic diagram on the foldout page at the rear of this manual while reading this section.

Automatic Crossover

The PS 501 (-1) (-2) employs two operational amplifiers; U40 and U70. Amplifier U40 controls output voltage while U70 controls output current. For any value of load resistance the power supply acts either as a constant-voltage source or a current source—but never both. Automatic crossover is accomplished by combining the outputs from pin 6 of U40 and U70 in a negative voltage divider configuration (see Fig. 3-1). The amplifier with the

lower output voltage at pin 6 will cause its associated diode (CR40 or CR71) to conduct, which eventually reverse biases the other diode. A portion of the current available from R51 is then diverted away from the base of Q50 and to the amplifier with the lower output. The remainder of the current drives the base of Q50 which, in turn, controls the current through the series-pass transistor to the load.

Constant Voltage/Current Limited Output

Output current or voltage varies when an imbalance occurs between the comparison voltage at pin 2 and 3 of either U40 or U70. This imbalance is caused by changing the load resistance or in the reference voltage selected by R65, the front-panel CURRENT LIMIT potentiometer, or by R42, the front-panel VOLTS potentiometer. Fig. 3-2 illustrates the output characteristics of the power supply with various current and voltage settings and load resistances.

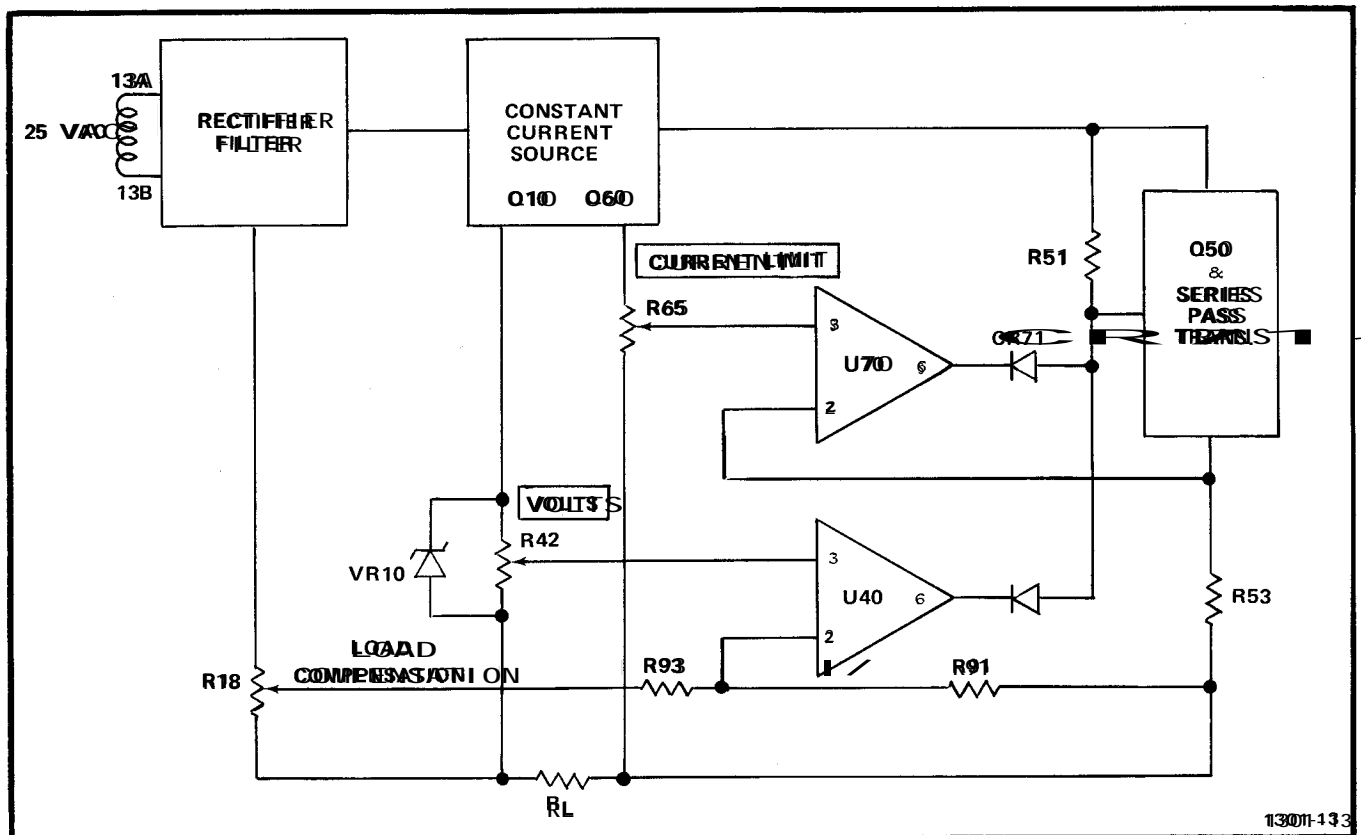

Fig. 3-1. Simplified diagram of PS 501 (-1, -2).

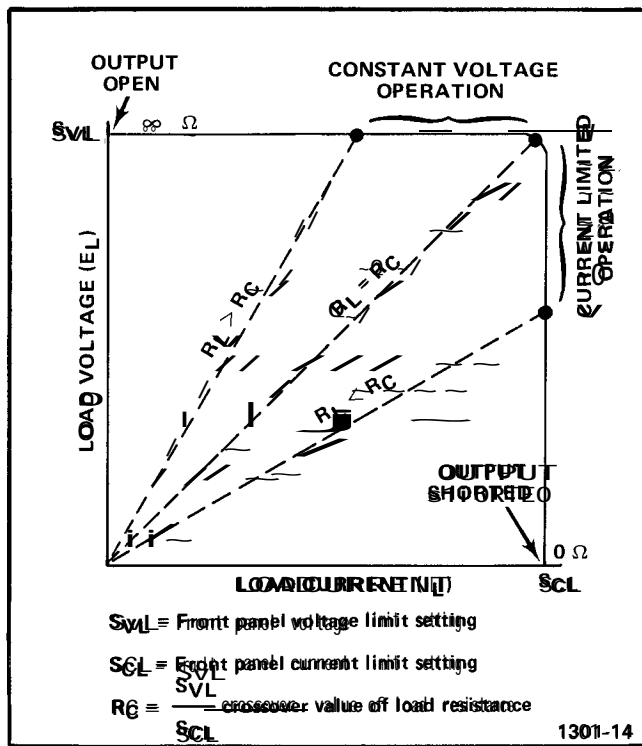

Fig. 3-2. Operating characteristics with varying currents, voltages, and loads.

Voltage and current references are generated from two constant current sources. Q10 and Zener diode VR10 provide a constant current to VOLTS potentiometer R42 which then establishes the non-inverting reference input to pin 3 of U40, the voltage control amplifier. The collector of Q60 provides constant current to CURRENT LIMIT potentiometer R65 which establishes the non-inverting reference input to pin 3 of U70, the current control amplifier.

With no load connected to the output terminals, $R_L = \infty$, $I_L = 0$ and $E_L = SVL$, the front-panel voltage limit setting (see Fig. 3-2). When a load is connected to the power supply output terminals, output current increases and results in an increase in the voltage drop across current-sensing resistor R55. This drop provides the inverting input to pin 2 of U70. If the voltage at pin 2 exceeds the reference voltage at pin 3, then the voltage at pin 2 drops to a level where CR71 turns on, and CR40s reverse biased; thus, control crosses over to U70, the current controlling amplifier. U70 holds the voltage at pin 2 to that set at pin 3

by R65, the CURRENT LIMIT potentiometer (SCL). The supply is now in current-limited operation (see Fig. 3-2).

Load Regulation

With no load connected to the output terminals of the PS 501 (-1) (-2), all of the output current flows through feedback divider R81/R83 (approximately 1 mA/V). When a load is connected to the output terminals, output current must increase to maintain a constant output voltage.

An increase in output current cannot occur unless the drive to the base of Q50 and the series pass transistor is also increased. The increase in the voltage differential between pin 2 and 3 of U40 necessary to drive Q50 and the series pass transistor (refer to the discussion of constant voltage/current-limited operation) is obtained by applying a small negative voltage developed by the load current through R15 in parallel with Load Compensation resistor R18. By adjusting R18, the proper feedback is developed through divider R81/R83 to increase the output current and subsequently hold the output voltage constant regardless of the load.

Line Regulation

Resistors R102, R103, and R14 enhance the stability of zener reference VR10 by establishing the zener current at approximately 7.5 mA. R102 stabilizes the zener current with respect to the line voltage. VR11 and R11 provide a reference voltage to constant current source Q10.

If the line voltage varies, a corresponding voltage change occurs across C10. This voltage change would normally affect the collector current through Q10. However, the self-bias generated across R13 and R14 partially stabilizes the collector current; further stabilization occurs when the current through R12 is added to the self-bias from R13 and R14. The nearly constant voltage drop across R14 provides bias for constant current source Q60, while CR66 provides temperature compensation.

+5V/Ground Referenced Supply

The Power Module supplies +5 V through pins 2A and 3A on the plug-in rear connector to pin 1 and 3 of integrated circuit U2. U2 provides a regulated +5V output limited at 1A from pin 2 and 3 to output connectors J5 and J6 on the front panel.

CALIBRATION PROCEDURE

PERFORMANCE CHECK PROCEDURE

Introduction

The performance check procedure checks the electrical performance requirements listed in the Specification section in this manual. Perform the Adjustment procedure if the instrument fails to meet these checks. If recalibration does not correct the discrepancy, troubleshooting is indicated. This procedure may be used to determine acceptability of performance in an incoming inspection facility.

For convenience, some steps in the procedure check the performance of this instrument at only one value in the specified performance range. Performance requirements for various temperature ranges are listed in this procedure. When performing the procedure, use only the limits listed for the ambient temperature that the instrument is operating in.

Calibration Interval

To ensure instrument accuracy, check the calibration every 2000 hours of operation or at a minimum of every six months if used infrequently.

Services Available

Tektronix Inc., provides complete instrument repair and adjustment at local field service centers and at the factory service center. Contact your local Tektronix field office or representative for further information.

Test Equipment Required

The following test equipment or equivalent is suggested to perform the Performance Check and Adjustment Procedure.

Table 4-1

TEST EQUIPMENT REQUIRED

| Performance Description | Requirement | Application | Example |
|-------------------------|---|----------------------------|---|
| Oscilloscope | 2 mV/Div, 5 MHz | Ripple Check | TEKTRONIX T921, T922 |
| Power Module | | All Checks | TEKTRONIX TM503, TM504 |
| Digital Voltmeter | 0 to 25 Vdc; 0 to 2 Adc; 0.1% accuracy | Voltage and current checks | TEKTRONIX DV501A, DV502A |
| Load Resistors | 2 k Ω 5 W, 10 Ω 25 W 5 Ω 25 W | Current Checks | Tektronix Part Numbers 308-0003-00 308-0164-00 308-0177-00 |
| Variable Transformer | 100 V to 130 V | Line Voltage Checks | |

PRELIMINARY PROCEDURE

1. Ensure that the power module regulating range selected includes the applied line voltage. Refer to the installation section of the power module manual.

2. Ensure that all test equipment is suitably adapted to the applied line voltage.

3. Install the PS 501 into the power module and, if applicable, install the TW500-Series test equipment into the test equipment power module.

4. Connect the equipment under test and the test equipment to a suitable line voltage source. Turn on all equipment and allow at least 20 minutes for the equipment to stabilize.

1. Check Output Voltage Range

a. Connect the output of the variable supply to the digital voltmeter.

b. CHECK that the VOLTS control can vary the output voltage from 0 V to 20 V. (19.99 V for PS 501-1.)

2. CHECK Current Limit Range

a. Connect the output of the variable supply to the digital voltmeter.

b. Set the output voltage to 20 V.

c. Set the CURRENT LIMIT control to minimum.

d. Connect the 2 k Ω resistor across the output of the power supply and CHECK that the limit light comes on. Remove the resistor.

e. Set the CURRENT LIMIT control to maximum.

f. Connect the 50 Ω resistor across the output.

g. CHECK that the current limit light comes on when the CURRENT LIMIT control is rotated towards minimum. Remove the resistor.

3. CHECK Output Accuracy (PS 501-1 and PS 501-2)

a. Connect the output of the variable supply to the digital voltmeter.

b. CHECK the output voltage when the supply is set to 5 V, 10 V, 15 V, and 20 V (± 0.04 V for the PS 501-2, $\pm 0.55\%$ for the PS 501-1).

4. CHECK Line and Load Regulation

a. Connect the output of the variable supply to the digital voltmeter. Connect the variable transformer in series with the power module input power. Set the voltage to 117 V.

b. Set the output VOLTAGE to 20 V.

c. Set the CURRENT LIMIT to maximum (fully cw).

d. Connect the 50 Ω resistor to the output and CHECK that the output voltage does not change more than 1 mV.

e. Vary the input line voltage to 105 V and then to 129 V.

f. CHECK that the output voltage does not vary more than ± 5 mV.

g. Remove the digital voltmeter and connect the oscilloscope to the power supply output. Do not remove the 50 Ω resistor.

h. CHECK that the ripple and noise is 5 mV or less. Remove the 50 Ω resistor.

5. CHECK Output Voltage of 5 V Supply

a. Connect the digital voltmeter to the output of the 5V supply.

b. CHECK that the voltage is between +4.75 and +5.25 V.

c. CHECK that the output voltage varies 100 mV or less when the 5 Ω resistor is connected across the output.

d. CHECK that the output voltage varies 50 mV or less as the line voltage is changed from 117 V to 105 V and that

it also varies 50 mV or less as the line voltage is changed from 117 V to 129 V.

e. Remove the digital voltmeter and connect the oscilloscope to the output of the 5 V supply. Do not remove the 5 Ω resistor.

f. CHECK that there is 5 mV or less ripple (peak-to-peak) with the 1 A load.

g. Remove the test equipment. This completes the performance check.

Calibration Procedure—PS 501 (-1, -2)
Adjustment Procedure

ADJUSTMENT PROCEDURE

Preliminary Information

Read the Operating Instructions in Section 2 before calibrating the instrument.

This instrument should be calibrated in an ambient temperature between +20°C and +30°C (+68°F and +86°F) for specified accuracy.

Do not preset internal controls unless they are known to be significantly out of adjustment, or if repairs have been made in the circuit. In these instances, the internal adjustments can be set to mid-range.

Preparation

a. Remove the cover from the left side of the PS 501 (-1) (-2) and if necessary, blow off accumulated dust with low pressure air.

b. Insert the PS 501 (-1) (-2) into the left compartment of the power module. It may be more convenient to use the flexible plug-in extender, to make the internal adjustments, but it is not mandatory. If the flexible extender is not used, it will be necessary to remove the power module cover.

c. Refer to the fold-out adjustments page for the location of internal adjustments.

1. ADJUST Load Compensation (R18)

a. Connect the 50 Ω resistor across the PS 501 (-1) (-2) variable supply output terminals.

b. AC couple the Test Oscilloscope to the output terminals and turn the front panel VOLTS and CURRENT LIMIT controls fully clockwise. Note the displayed level on the Test Oscilloscope.

c. Remove the load resistor and note the shift in the displayed level.

d. ADJUST R18 (Load Compensation) for no shift in the displayed level as the load resistor is connected and disconnected.

2. ADJUST Zero Volts (PS 501 and PS 501-2) (R38)

a. Connect the digital voltmeter to the variable power supply output terminals.

b. Set the front panel VOLTS control for zero volts (fully ccw).

c. ADJUST R38 for 0.00 V on the digital voltmeter.

d. Remove the digital voltmeter.

3. ADJUST One Volt Output (R38) (PS 501-1 only)

a. Connect the digital voltmeter to the variable power supply output terminals.

b. Set the front panel VOLTS control to 1.00 with the range pushbutton out (00-100V).

c. ADJUST R38 for 1.000 V at the output.

4. ADJUST ± 10 V and ± 20 V Outputs (PS 501-1 only) (R42B and R45)

a. Connect the digital voltmeter to the PS 501-1 output terminals.

b. Set the front panel VOLTS control fully ccw to 0.00. Don't set it beyond 0.00.

c. Press the range push button in (100-20V).

d. ADJUST R42B (± 20 V) for 20.03 on the digital voltmeter.

e. Release the range push button to the out position (00-10V).

f. ADJUST R45 (± 10 V) for 10.00 V on the digital voltmeter.

g. INTERACTION Repeat adjustments of R38 (One Volt Adjust), R42B (± 20 V), and R45 (± 10 V) until interaction is minimized.

h. Remove the digital voltmeter.

i. This completes the adjustment procedure.

MAINTENANCE

GENERAL

Introduction

This section of the manual is meant to support the TM 500 Series with a general coverage of the most commonly-needed service information pertinent to preventive maintenance, troubleshooting, ordering parts, and replacing components and sub-assemblies.

Cabinet Removal

WARNING

Dangerous potentials may exist at several points throughout the system. When the system must be operated with the cabinet removed, do not touch exposed connections or components. Some transistors have voltage present on their cases. Disconnect power before cleaning the system or replacing parts.

Cleaning

CAUTION

Avoid using chemical cleaning agents that might damage plastic parts. Avoid chemicals containing benzene, toluene, xylene, acetone, or similar solvents.

Exterior. Loose dust may be removed with a soft cloth or a dry brush.

Interior. Cleaning the interior of a unit should precede calibration since the cleaning processes could alter the settings of calibration adjustments. Use low-velocity compressed air to blow accumulated dust. Harder dirt can be removed with a soft brush, cotton-tipped swab, or a cloth dampened in a solution of water and mild detergent.

Preventive Maintenance

Preventive maintenance steps performed on a regular basis will enhance the reliability of the instrumentation systems. However, periodic checks of the semiconductors in the absence of a malfunction are not recommended as preventive maintenance measures. See the semiconductor checking information under Troubleshooting Techniques, which follow. A convenient time to perform preventive maintenance is just before instrument calibration.

Calibration

To ensure accurate signal generation and measurement, the performance of individual units in the system should be checked periodically. Refer to the Instruction Manual for each unit for complete calibration and verification procedures.

TROUBLESHOOTING AIDS

Introduction

The following is provided to augment information contained elsewhere in this and other TM/500 series family manuals when troubleshooting becomes necessary.

Circuit Description

Each manual has a section devoted to explaining circuit operating theory. Used with the schematics, this can be a powerful analytic tool.

Diagrams

Block diagrams and detailed circuit schematics are located on foldout pages in the service section of most of the TM/500 Series Family manuals. The schematic diagrams show the component values and assigned circuit reference numbers of each part of the circuit. Usually the first page of the service section defines the circuit symbols and reference designators used in that particular instrument. Major circuits are usually identifiable by a series of component numbers. Important waveforms and voltages may be shown within the diagrams or on adjoining aprons. Those portions of the circuits located on circuit boards are enclosed with a dark outline.

Cam Switch Charts

Cam switches shown on the diagrams are coded on charts to locate the cam number of the switch contact in the complete switch assembly, counting from the front, or knob end, toward the rear of the switch. The charts indicate with a solid dot when each contact is closed.

Circuit Board Illustrations

Line illustrations showing component locations keyed with a grid scheme for each circuit board are usually placed on the back of a foldout page and sequenced as close as possible to an associated schematic. The GRID LOG columns, located near the Parts Location Grid, keys each component to easy location on the board.

Component and Wiring Color Codes

Color stripes or dots on electrical components signify electrical values, tolerances, etc., according to EIA standards. Components not color-coded usually have information printed on the body. The wiring coding follows the same EIA standards with the exception of the ac power cord of the Power Module. It is coded like this:

POWER CORD CONDUCTOR IDENTIFICATION

| Conductor | Color | Alternate Color |
|----------------------|--------------|-----------------|
| Underground (Line) | Brown | Black |
| Grounded (Neutral) | Blue | White |
| Grounding (Earthing) | Green-Yellow | Green-Yellow |

Testing Equipment

Generally, a wide-band oscilloscope, a probe, and a multimeter are all that is needed to perform basic waveform and voltage checks for diagnostic purposes. The calibration procedures list specific test equipment and the features necessary to adequately check out the module.

TROUBLESHOOTING TECHNIQUES

Introduction

This troubleshooting procedure is arranged in an order that checks the simple trouble possibilities before proceeding to extensive troubleshooting.

Control Settings

An apparent trouble may only be incorrect control settings. If there is any question about the correct function or operation of any control, see the Operating Instructions section of the manual.

System and Associated Equipment

Before proceeding with troubleshooting the TM500 Series system, check that the instruments in the system are operating correctly. Check for proper interconnection between the power module and the plug-in modules. Check the line voltage at the power source. Verify that the signal is properly connected and that the interconnecting cables and signal source are not defective.

The associated plug-in modules can be checked for proper operation quickly by substituting other like units known to be operating properly. If the trouble persists after substitution, then the power module is probably at fault. Moving a properly operating plug-in from compartment to compartment will help determine if one or more compartments have a problem.

Visual Check

Inspect the portion of the system in which the trouble is suspected. Many troubles can be located by visual clues such as unsoldered connections, broken wires, damaged circuit board, damaged components, etc.

Instrument Calibration

Check the calibration of the suspected plug-in module or the affected circuit if the trouble is obviously in a certain circuit. The trouble may only be a result of misadjustment or maybe corrected by re-calibration. Complete calibration instructions are given in the manual for each instrument in the system.

Circuit Isolation

Note the trouble symptoms. These often identify the circuit in which the trouble is located. When trouble symptoms appear in more than one circuit, check the affected circuits by making waveform and voltage measurements.

Incorrect operation of all circuits often means trouble in the power supplies. Using a multimeter, check first for correct voltages of the individual regulated supplies according to the plug-in module schematics and calibration procedures. Then check the unregulated supplies of the power modules. Defective components elsewhere in the instruments can appear as power supply problems. In these instances, suspected circuits should be disconnected from apparently bad power supplies once at a time to narrow the search.

Voltages and Waveforms

Often defective components can be located by using waveform and voltage indications when they appear on the schematic or in the calibration procedures. Such waveforms and voltage labels are typical indications and will vary between instruments. To obtain operating conditions similar to those used to take these readings, refer to the first diagram in the service sections.

Component Checking

If a component cannot be disconnected from its circuit, then the effects of the associated circuitry must be considered when evaluating the measurement. Except for soldered-in transistors and integrated circuits, most components can be unsoldered and lifted at one end from the circuit board.

Transistors and IC's. Turn the power-switch off before removing or replacing any semiconductor.

A good check of transistor operation is actual performance under operating conditions. A transistor can most effectively be checked by substituting a new component for it (or one which has been checked previously). However, be sure that circuit conditions are not such that a replacement transistor might also be damaged. If substitute transistors are not available, use a dynamic tester. Static-type testers are not recommended, since they do not check operation under simulated operating conditions. An antistatic suction-type desoldering tool must be used to remove soldered-in transistors; see component replacement procedure for details.

Integrated circuits can be checked with a voltmeter, test oscilloscope, or by direct substitution. A good understanding of the circuit description is essential to troubleshooting circuits using IC's. Operating waveforms, logic levels, and other operating information for the IC's are given in the circuit description information of the appropriate manual. Use care when checking voltages and waveforms around the IC's so that the adjacent leads are not shorted together. A convenient means of clipping a test probe to the 14- and 16-pin in-line IC's is with an integrated circuit test clip. This device also doubles as an extraction tool.

Diodes. A diode can be checked for an open or shorted condition by measuring the resistance between terminals with an ohmmeter on a scale having a low internal source current, such as the RX1k scale. The resistance should be very high in one direction and very low when the meter leads are reversed.

CAUTION

When checking diodes, do not use an ohmmeter scale that has a high internal current since high currents may damage the diodes under test.

Resistors. Check the resistors with an ohmmeter. Resistor tolerances are given in the Electrical Parts List in every manual. Resistors do not normally need to be replaced unless the measured value varies widely from the specified value.

Capacitors. A leaky or shorted capacitor can be detected by checking resistance with an ohmmeter on the highest scale. Use an ohmmeter that will not exceed the voltage rating of the capacitor. The resistance reading should be high after initial charge of the capacitor. An open capacitor can best be detected with a capacity meter, or by checking whether it passes ac signals.

PARTS ORDERING AND REPLACING

Ordering

Obtaining Replacement Parts. Most electrical and mechanical parts can be obtained through your local

Tektronix field office or representative. However, you should be able to obtain many of the standard electronic components from a local commercial source in your area. Before you purchase or order a part from a source other than Tektronix, Inc., please check the electrical parts list for the proper value, rating tolerance and description.

Special Parts. Some parts are manufactured or selected by Tektronix, Inc., to satisfy particular requirements, or are manufactured for Tektronix, Inc., to our specifications. Most of the mechanical parts used in this system have been manufactured by Tektronix, Inc. Order all special parts directly from the local Tektronix field office or representative.

Ordering Procedure. When ordering replacement parts from Tektronix, Inc., please include the following information:

1. Instrument Type (PS 501, SG 502, DC 501, etc.)
2. Instrument Serial Number (For example, B0102511)
3. A description of the part (if electrical include the circuit number)
4. Tektronix part number.

Please do not return any instruments or parts before receiving directions from Tektronix, Inc.

A listing of Tektronix Field Offices, Service Centers and representatives can be found in the Tektronix Product Catalog and Supplements.

Replacing

The exploded view drawings associated with the Mechanical Parts List, located to the rear of most manuals, may be especially helpful when disassembling or reassembling individual components or sub-assemblies.

Circuit Boards. If a circuit board is damaged beyond repair, the entire assembly including all soldered-on components, can be replaced.

To remove or replace a board, proceed as follows:

1. Disconnect all leads connected to the board (both soldered lead connections and solderless pin connections).

Maintenance—PS 501 (-1, -2)

2. Remove all screws holding the board to the chassis or other mounting surface. Some boards may be held fast by plastic mounting clips around the board edges. For these, push the mounting clip away from the circuit board edges to free the board. Also, remove any knobs, etc., that would prevent the board from being lifted out of the instrument.

3. Lift the circuit board out of the unit. Do not force or bend the board.

4. To replace the board, reverse the order of removal. Use care when replacing pin connectors. If forced into place incorrectly positioned, the pin connectors may be damaged.

Transistors and ICs. Transistors and ICs should not be replaced unless they are actually defective. If removed from their sockets during routine maintenance, return them to their original sockets. Unnecessary replacement or switching of semiconductor devices may affect the calibration of the instruments. When a transistor is replaced, check the operation of the part of the instrument that may be affected.

Replacement semiconductors should be of the original type or a direct replacement. Figure 5-1 shows the lead configurations of the semiconductors used in this instrument system. When removing solder in transistors, use a suction-type desoldering tool to remove the solder from the holes in the circuit board.

An extracting tool should be used to remove the 4- and 16-pin integrated circuits to prevent damage to the pins. This tool is available from Tektronix, Inc. If an extracting tool is not available, use care to avoid damaging the pins. Pull slowly and evenly on both ends of the IC. Try to avoid having one end of the IC disengage from the socket before the other end.

Static-Sensitive Components



Static discharge can damage any semiconductor component in this instrument.

This instrument contains electrical components that are susceptible to damage from static discharge. See Table 5-1 for relative susceptibility of various classes of semiconductors. Static voltages of 1 kV to 30 kV are common in unprotected environments.

Observe the following precautions to avoid damage:

1. Minimize handling of static-sensitive components.
2. Transport and store static-sensitive components or assemblies in their original containers, on a metal rail, or a conductive foam. Label any package that contains static-sensitive assemblies or components.
3. Discharge the static voltage from your body by wearing a wrist strap while handling these components. Servicing static-sensitive assemblies or components should be performed only at a static-free workstation by qualified service personnel.
4. Nothing capable of generating or holding a static charge should be allowed on the workstation surface.
5. Keep the component leads shorted together whenever possible.
6. Pick up components by the body, never by the leads.
7. Do not slide the components over any surface.
8. Avoid handling components in areas that have a floor or work surface covering capable of generating a static charge.
9. Use a soldering iron that is connected to earth ground.
10. Use only special antistatic suction type or wick type desoldering tools.

Test Equipment

Before using any test equipment to make measurements on static-sensitive components or assemblies, be certain that any voltage or current supplied by the test equipment does not exceed the limits of the component to be tested.

Interconnecting Pins. To replace a pin that is mounted on a circuit board, first disconnect any pin connectors. Then, unsolder the damaged pin and pull it out of the board with a pair of pliers. Be careful not to damage the wiring on the board with too much heat. Ream out the hole in the circuit board with a 0.031-inch drill. Remove the ferrule from the new interconnecting pin and press the new pin into the hole in the circuit board. Position the pin

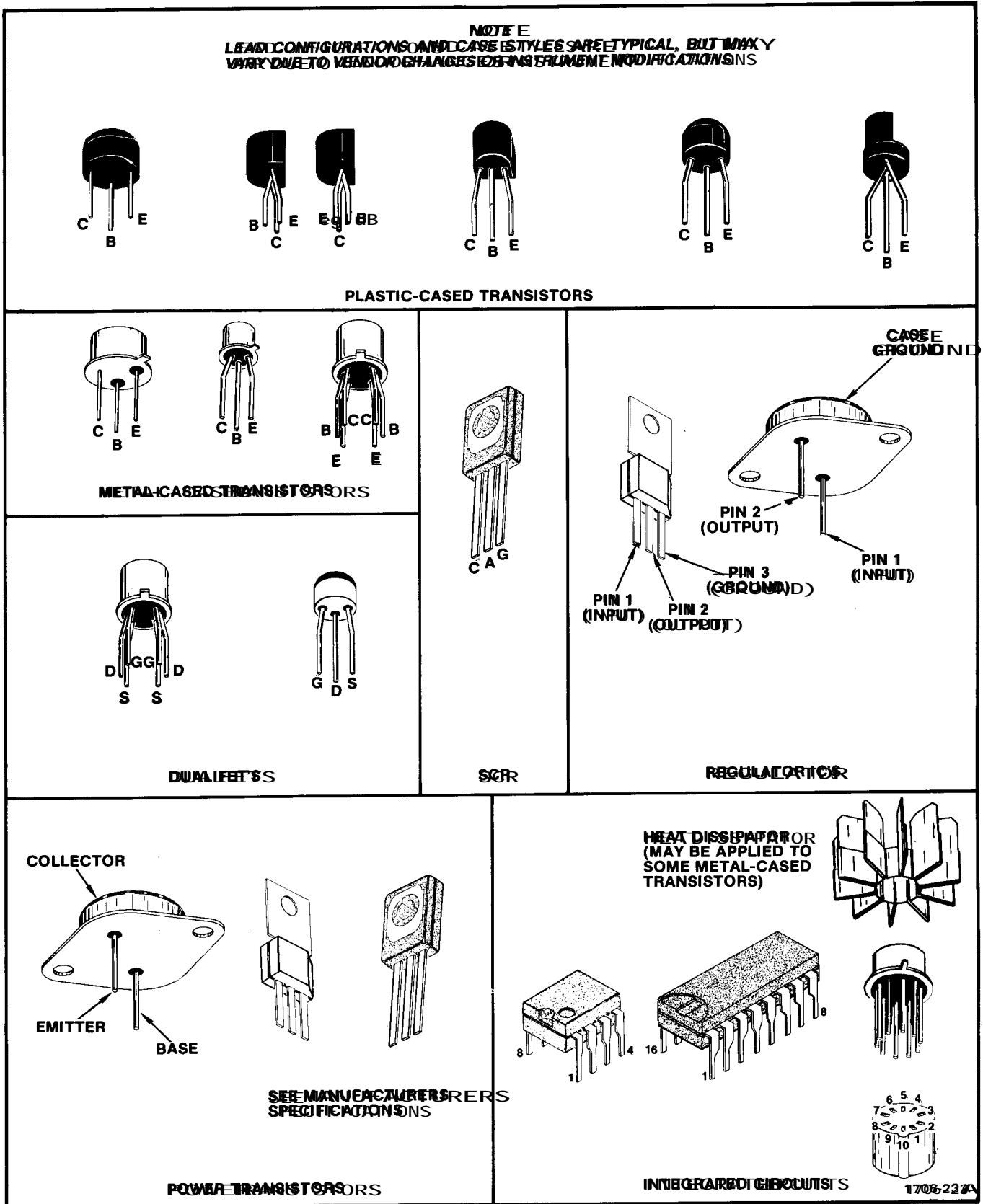
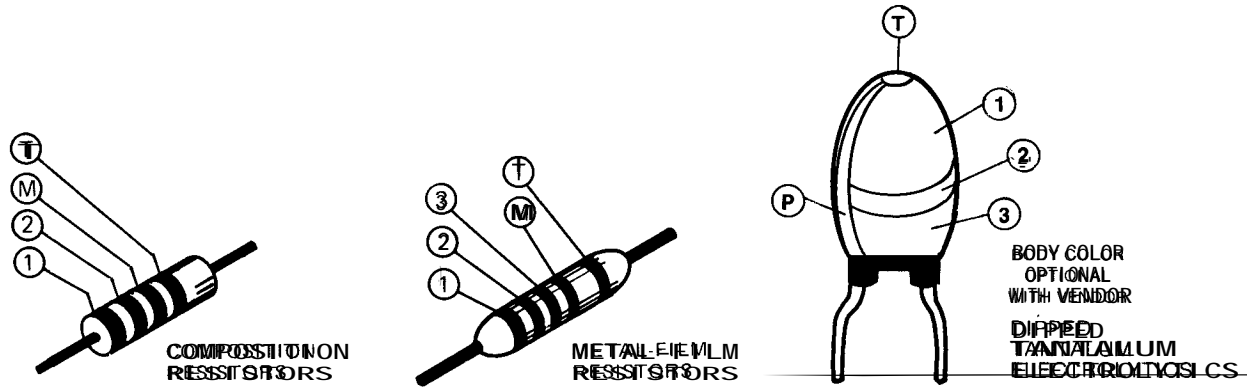

Fig. 5-11. Semiconductor device lead configurations found in the TMM500 family.



① ② and ③ - 1ST, 2ND, AND 3RD SIGNIFICANT FIGS. ④ AND ⑤ - COLOR CODE MAY NOT BE PRESENT ON SOME CAPACITORS

⑥ - MULTIPLIER ⑦ - TOLERANCE

⑧ - TEMPERATURE COEFFICIENT ⑨ - POLARITY AND VOLTAGE RATING

| COLOR | SIGNIFICANT FIGURES | RESISTORS | | CAPACITORS | | |
|--------|---------------------|--------------------------|-----------|-------------------------------|-----------|----------------|
| | | MULTIPLIER (OHMS) | TOLERANCE | MULTIPLIER (pF) | TOLERANCE | VOLTAGE RATING |
| BLACK | 0 | 1 | --- | | | 4VDC |
| BROWN | 1 | 10 | ±1% | | | 6VDC |
| RED | 2 | 10 ² or 100 | ±2% | | | 10VDC |
| ORANGE | 3 | 10 ³ or 1 K | ±3% | | | 15VDC |
| YELLOW | 4 | 10 ⁴ or 10K | ±4% | 10 ⁴ or 10,000 | | 20VDC |
| GREEN | 5 | 10 ⁵ or 100K | ±1/22% | 10 ⁵ or 100,000 | | 25VDC |
| BLUE | 6 | 10 ⁶ or 1 M | ±1/4% | 10 ⁶ or 1,000,000 | | 35VDC |
| VIOLET | 7 | --- | ±1/10% | 10 ⁷ or 10,000,000 | | 50VDC |
| GRAY | 8 | --- | --- | | | --- |
| WHITE | 9 | --- | --- | | | |
| GOLD | --- | 10 ⁻¹ or 0.1 | ±5% | --- | ±5% | --- |
| SILVER | --- | 10 ⁻² or 0.01 | ±10% | --- | ±10% | --- |
| NONE | --- | --- | ±20% | --- | ±20% | --- |

2815095, 1862892-74)

Fig. 5-2. Color code for resistors and capacitors.

in the same manner as the old pin and solder it in. If the old pin was bent at an angle to mate with a connector, bend the new pin to match the associated pins.

NOTE

A pin replacement kit including necessary tools, instructions, and replacement pins is available from Tektronix, Inc.

Table 5-1
RELATIVE SUSCEPTIBILITY TO
STATIC DISCHARGE DAMAGE

| Semiconductor Classes | Relative Susceptibility Levels ^a |
|--|---|
| MOS or CMOS microcircuits or discretes, or linear microcircuits with MOS inputs (Most Sensitive) | 1 |
| ECL | 2 |
| Schottky signal diodes | 3 |
| Schottky TTL | 4 |
| High-frequency bipolar transistors | 5 |
| JFETs | 6 |
| Linear Microcircuits | 7 |
| Low-power Schottky TTL | 8 |
| TTL (Least Sensitive) | 9 |

^a Voltage equivalent for levels:

1 = 100 to 500 V 4 = 500 V 7 = 400 to 1000 V (est.)
 2 = 200 to 500 V 5 = 400 to 600 V 8 = 900 V
 3 = 250 V 6 = 600 to 800 V 9 = 1200 V

(Voltage discharged from a 100 pF capacitor through a resistance of 100 ohms.)

Table 5-2
MAINTENANCE AIDS

The following maintenance aids include items required for some maintenance procedures in this instrument. Equivalent products may be substituted for examples given providing characteristics are similar.

| Description | Specifications | Use | Example |
|-----------------------------|--|-----------------------------------|--|
| 1. Soldering Iron | 15 Watt | General soldering and unsoldering | IAATEK PRECISION Model C |
| 2. Screwdriver | Phillips #1 tip | Assembly and Disassembly | Xcelite Model X108 |
| 3. Screwdriver | Phillips #2 tip | Assembly and Disassembly | Xcelite Model X102 |
| 4. Screwdriver | Three-inch shaft; 3/32 inch flat bit | General | Xcelite R3323 |
| 5. Torque Screwdriver | 1.5 inch-pounds | FUNCTION switch assembly | Sturtevant Richmond Torque Products Model PM-5-Roto-Torque |
| 6. Nutdrivers | 1/4 inch, 5/16 inch 3/8 inch, 7/16 inch | General | Xcelite #8, #10, #12 & #14 |
| 7. Open End Wrench | 11/16 inch | General | |
| 8. Solder Wick | | Unsoldering | HexWick #887-10 |
| 9. Lubricant | Versilube | FUNCTION switch lubrication | Tektronix Part Number 006-1353-00 |
| 10. Spray Cleaner | No Noise | FUNCTION switch pad cleaning | Tektronix Part Number 006-0442-02 |
| 11. Vacuum Desoldering Tool | Antistatic | General | Tektronix Part Number 003-0795-00 |
| 12. I.C. Extracting Tool | | General | Tektronix Part Number 003-0619-00 |
| 13. Cam Switch Repair Kit | | Cam switches | Tektronix Part Number 040-0541-00 |
| 14. Extender Cables | | General | Tektronix Part Number 067-0645-02 |
| 15. Wrist Strap | | Handling static sensitive devices | Tektronix Part Number 006-2404-01 |

Table 5-3

REAR CONNECTOR PIN ASSIGNMENTS

| | B | | A |
|--|----|--------------|---|
| | 28 | Power | 28 |
| | 27 | supply | 27 |
| Pin 3 of U70 | 26 | plug-in | 26 |
| Pin 3 of U40 | 25 | barrier slot | 25 |
| Reference Common | 24 | | 24 Reference Common |
| | 23 | | 23 Sense |
| | 22 | | 22 Output |
| Unregulated Common | 21 | | 21 Unregulated Common |
| | 20 | | 20 |
| Emitter of Series Pass Transistor | 19 | | 19 |
| | 18 | | 18 |
| | 17 | | 17 |
| | 16 | | 16 |
| | 15 | | 15 |
| | 14 | | 14 |
| 25 VAC Winding | 13 | | 13 25 VAC Winding |
| +335 V Filtered DC | 12 | | 12 +335 V Filtered DC |
| Collector lead of PNP Series-Pass Transistor | 11 | | 11 Base lead of PNP Series-Pass Transistor |
| Transformer Shield | 10 | TW500 | 10 Emitter lead of PNP Series-Pass Transistor |
| 33.5 V Common | 9 | barrier | 9 33.5 V Common |
| -335 V Filtered DC | 8 | slot | 8 -335 V Filtered DC |
| Collector lead of NPN Series-Pass Transistor | 7 | | 7 Emitter lead of NPN Series-Pass Transistor |
| Not Used | 6 | | 6 Base lead of NPN Series-Pass Transistor |
| 17.5 VAC Winding | 5 | | 5 17.5 VAC Winding |
| +11.5 V Common | 4 | | 4 +11.5 V Common |
| +11.5 V Common | 3 | | 3 +11.5 V Common |
| +11.5 V Filtered DC | 2 | | 2 +11.5 V Filtered DC |
| 25 VAC Winding | 1 | | 1 25 VAC Winding |
| | B | | A |

Rear-view of plug-in

Assignments listed for pins 1A-13A and 1B-13B are available in all power modules.

PS 501, PS 501-1, REAR INTERFACE INPUT-OUTPUT CONTACT ASSIGNMENTS

The keyslot between contacts 19 and 20 identify the PS 500 Power Supplies as members of TM500 Series Family "C". Once a Power Module compartment has been wired with specialized interconnections for these Power Supply plug-ins, a barrier should be installed in that compartment to match the keyslot. For extra barriers, order Tektronix part number 214-1593-02.

All of the assigned pads of these power supplies are connected to circuitry by ECBBs. Unassigned pins are available at the rear connector for routing signals to and from the PS 501s for specialized applications. One or more compartments of a Power Module can be wired with barriers installed to provide specific functions between compartments.

The reference common and the load commons (sometimes referred to as unregulated commons) are all floating. Grounding of the plus or minus terminal determines the output voltage polarity.

Remote voltage programming is possible through the PS 501 and PS 501-1 rear interface contacts. 25B is the positive rear interface input voltage contact, and 24A or 24B is the minus return. (Ref. common) A one volt input will produce approximately 3V at the front panel output. A single precaution should be taken. Disconnect the COARSE VOLTS potentiometer center-tap lead to avoid overloading the external voltage source.

No external load should be provided for the remote voltage input.

The rear interface contact 26B assignment is plus Input Remote Current Limit. The minus end of the input voltage is tied to contact 22A. In remote current limiting, lift the center-tap of the front panel CURRENT LIMIT potentiometer. The current limiting control voltage factor is 2 V/A, up to the maximum output capability of the Power Supply, which typically exceeds 100 mA. The output is about another 100 mA.

If an operator desires output current monitoring, connect a voltmeter from rear I/O contacts 19B and 22A. (The current limiting output is developed between these contacts.) The internal 2 Ω resistor will drop 1 V per 500 mA.

Some operators may wish to use rear interface connection 23A for remote sensing, in which case the front panel connection must be lifted. The sense connections then will provide proper regulation to external equipment wired to the Power Module. The sense leads should be connected to an OpAmp, so for remote sensing through the rear interface, the OpAmp senses the voltage at the load. Keep the wiring as short as possible.

When using a PS 500 Series Power Supply rear interface for remote sensing, it is good practice to connect a filter capacitor across the load. (Approximately 100 pfd) This is to prevent oscillations and spurious signals from occurring.

For remote sensing, the positive side of the external load is connected to rear interface I/O contact 23A. Contact 24A or 24B (the minus return) is connected to the negative side of the load.

It is possible to use remote sensing while using remote voltage programming via the rear interface.

The positive regulated output is obtained from 22A, with 24A-B, the reference common.

REPACKAGING FOR SHIPMENT

If the Tektronix instrument is to be shipped to a Tektronix Service Center for service or repair, attach a tag showing owner (with address), the name of an individual at your firm that can be contacted, complete instrument serial number and a description of the service required.

Save and re-use the package in which your instrument was shipped. If the original packaging is unfit for use or not available, repack the instrument as follows:

Surround the instrument with polyethylene sheeting to protect the finish of the instrument. Obtain a carton of corrugated cardboard of the correct carton strength and having inside dimensions of no less than six inches more than the instrument dimensions. Cushion the instrument by tightly packing three inches of dunnage or urethane foam between carton and instrument, on all sides. Seal carton with shipping tape or industrial stapler.

The carton test strength for your instrument is 200 pounds.

OPTIONS

None available at this time.

REPLACEABLE ELECTRICAL PARTS PARTS ORDERING INFORMATION ON

Replacement parts are available from or through your local Tektronix, Inc. Field Office or representative.

Changes to Tektronix instruments are sometimes made to accommodate improved components as they become available, and to give you the benefit of the latest circuit improvements developed in our engineering department. It is therefore important, when ordering parts, to include the following information in your order: Part number, instrument type or number, serial number, and modification number if applicable.

If a part you have ordered has been replaced with a newer improved part, your local Tektronix, Inc. Field Office or representative will contact you concerning any change in part number.

Change information, if any, is located at the rear of this manual.

Only the circuit number will appear on the diagrams and circuit board illustrations. Each diagram and circuit board illustration is clearly marked with the assembly number. Assembly numbers are also marked on the mechanical exploded views located in the Mechanical Parts List. The component number is obtained by adding the assembly number prefix to the circuit number.

The Electrical Parts List is divided and arranged by assemblies in numerical sequence (e.g., assembly A1 with its subassemblies and parts, precedes assembly A2 with its subassemblies and parts).

Chassis-mounted parts have no assembly number prefix and are located at the end of the Electrical Parts List.

LIST OF ASSEMBLIES

A list of assemblies can be found at the beginning of the Electrical Parts List. The assemblies are listed in numerical order. When the complete component number of a part is known, this list will identify the assembly in which the part is located.

CROSS INDEX MFR. CODE NUMBER TO MANUFACTURER

The Mfr. Code Number to Manufacturer index for the Electrical Parts List is located immediately after this page. The Cross Index provides codes, names and addresses of manufacturers of components listed in the Electrical Parts List.

ABBREVIATIONS

Abbreviations conform to American National Standard Y1.1.

COMPONENT NUMBER (column one of the Electrical Parts List)

A numbering method has been used to identify assemblies, subassemblies and parts. Examples of this numbering method and typical expansions are illustrated by the following:



Read: Resistor 1234 of Assembly 23

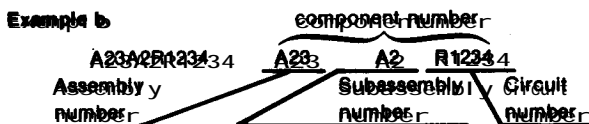

Read: Resistor 1234 of Subassembly 2 of Assembly 23

TEKTRONIX PART NO. (column two of the Electrical Parts List)

Indicates part number to be used when ordering replacement part from Tektronix.

SERIAL MODEL NO. (columns three and four of the Electrical Parts List)

Column three (3) indicates the serial number at which the part was first used. Column four (4) indicates the serial number at which the part was removed. No serial number entered indicates part is good for all serial numbers.

NAME & DESCRIPTION (column five of the Electrical Parts List)

In the Parts List, an item name is separated from the description by a colon (:). Because of space limitations, an item name may sometimes appear as incomplete. For further item name identification, the U.S. Federal Cataloging Handbook H6-1 can be utilized where possible.

MFR CODE (column six of the Electrical Parts List)

Indicates the code number of the actual manufacturer of the part. (Code name and address cross reference can be found immediately after this page.)

MFR. PART NUMBER (column seven of the Electrical Parts List)

Indicates actual manufacturer part number.

Replaceable Electrical Parts—PS 501 (-1, -2)

CROSS INDEX BY MANUFACTURER CODE NUMBER TO MANUFACTURER

| Mfr. Code | Manufacturer | Address | City, State, Zip |
|-----------|--|---|---------------------------|
| 01121 | ALLEN BRADLEY COMPANY | 1201 2ND STREET SOUTH | MILWAUKEE WI 53204 |
| 01285 | TEXAS INSTRUMENTS, INC., SEMICONDUCTOR GROUP | P O BOX 5012, 13500 N CENTRAL EXPRESSWAY ROUTE 202 | DALLAS, TX 75222 |
| 02735 | RCA CORPORATION, SOLID STATE DIVISION | 5005 E MCDOWELL RD P O BOX 20923 | SOMERVILLE, NY 08876 |
| 04713 | MOTOROLA, INC., SEMICONDUCTOR PROD DIV. | | PHOENIX, AZ 85038 |
| 07263 | FAIRCHILD SEMICONDUCTOR DIV. OF FAIRCHILD CAMERA AND INSTRUMENT CORP. | 464 ELLIS STREET | MOUNTAIN VIEW, CA 94042 |
| 12697 | CLAROSTAT MFG CO, INC. | LOWER WASHINGTON STREET | DOVER, NH 03820 |
| 14433 | ITT SEMICONDUCTORS | 3301 ELECTRONOS WAY P O BOX 3049 | WEST PALM BEACH, FL 33402 |
| 15238 | ITT SEMICONDUCTOR BOARD DIVISION OF INTER NATIONAL TELEPHONE AND TELEGRAPH CORP. | P.O. BOX 168, 500 BROADWAY | LAWRENCE, MA 01841 |
| 31918 | IEEE BOARDING | 8081 WALLACE ROAD | EDEN PRAIRIE, MN 55348 |
| 32997 | BONJON, INC., TERMINAL PRODUCTS DIV. | 1200 COLUMBIA AVE | RIVERSIDE, CA 92507 |
| 33005 | JEWELL ELECTRICAL INSTRUMENTS, INC. | GRENFIELD | MANCHESTER, NH 03105 |
| 50434 | HEWLETT PACKARD COMPANY | 640 PAGE HILL ROAD | PALO ALTO, CA 94304 |
| 50522 | MONSANTO CO, ELECTRONIC SPECIAL PRODUCTS | 3400 HILLVIEW AVENUE | PALO ALTO, CA 94304 |
| 56289 | SIPAQUE ELECTRIC CO | 87 MARSHALL ST. | ROBERT ADAMS, MA 01247 |
| 58474 | SUPERIOR ELECTRIC CO | 388 MIDDLE ST. | BRISTOL, CT 06010 |
| 71460 | CTS CORP | 905 N WEST BLVD | ELKHART, IN 46514 |
| 71744 | CHICAGO MINIATURE ELECTRONICS | 4433 RAKENSWOOD AVE | CHICAGO, IL 60640 |
| 80009 | TEKTRONIX, INC. | P O BOX 500 | BEAVERTON, OR 97077 |
| 87084 | ILLUMINATED PRODUCTS, INC., A SUB OF OAK INDUSTRIES, INC. | 2620 SUSSEX ST, P O BOX 11930 | SANTA ANA, CA 92711 |
| 90201 | MALLOY MANUFACTURING CO, DIV. OF P. R. MALLOY MFG CO, INC. | 3029 E WASHINGTON STREET P O BOX 372 | INDIANAPOLIS, IN 46206 |
| 91637 | DALE ELECTRONICS, INC. | P O BOX 809 | COLUMBIANA, NE 68601 |

Replaceable Electrical Parts—PS 501 (-1, -2)

| Kt No | Tektronix Part No | Serial/Model No Eff | Discont | Name & Description | Mfr Cost | Mfr Part Number |
|-------|-------------------|---------------------|----------|---|----------|--------------------|
| A1 | 670-2012-00 | | | CKT BOARD ASSY MAIN (PS501 ONLY) | 80009 | 670-2012-000 |
| A1 | 670-2116-00 | B0101000 | B0515569 | CKT BOARD ASSY MAIN (PS501-1 ONLY) | 80009 | 670-2116-000 |
| A1 | 670-2116-01 | B0515700 | B0526449 | CKT BOARD ASSY MAIN (PS501-1 ONLY) | 80009 | 670-2116-011 |
| A1 | 670-2116-02 | B0526500 | 056209 | CKT BOARD ASSY MAIN (PS501-1 ONLY) | 80009 | 670-2116-022 |
| A1 | 670-2116-03 | B0562100 | | CKT BOARD ASSY MAIN (PS501-1 ONLY) | | 670-2116-033 |
| A1 | 670-2673-00 | B0101000 | B0411139 | CKT BOARD ASSY MAIN (PS501-2 ONLY) | 80009 | 670-2673-000 |
| A1 | 670-2673-01 | B0411140 | | CKT BOARD ASSY MAIN (PS501-2 ONLY) | 80009 | 670-2673-011 |
| A2 | 670-2089-00 | | | CKT BOARD ASSY SECONDARY (PS501-1 ONLY) | 80009 | 670-2089-000 |
| C2 | 283-0198-00 | | | CAP.FKD.CEERD1:0.22UF,20%,50V | 56289 | 1C1025U223M050B50B |
| C3 | 290-0531-00 | | | CAP.FKD.ELECTUT:100UF,20%,10V | 90201 | T0C10761010W1CWL C |
| C10 | 290-0520-00 | B0101000 | B0299999 | CAP.FKD.ELECTUT:4500UF,100%,40V | 56289 | 68D10474 |
| C10 | 290-0509-00 | B0300000 | | CAP.FKD.ELECTUT:3900UF,100-100%,50V | 56289 | 68D10454 |
| C20 | 290-0324-00 | B0101000 | B0504099 | CAP.FKD.ELECTUT:780UF,+75-10%,40V (PS501 ONLY) | 56289 | D46454 |
| C20 | 290-0509-00 | B0504100 | | CAP.FKD.ELECTUT:3900UF,100-100%,50V (PS501 ONLY) | 56289 | 68D10454 |
| C20 | 290-0324-00 | B0101000 | B0505299 | CAP.FKD.ELECTUT:750UF,+75-10%,40V (PS501-1 ONLY) | 56289 | D46454 |
| C20 | 290-0509-00 | B0505300 | | CAP.FKD.ELECTUT:3900UF,100-100%,50V (PS501-1 ONLY) | 56289 | 68D10454 |
| C35 | 290-0524-00 | | | CAP.FKD.ELECTUT:4.7UF,20%,10V | 90201 | T0C475M0510EL |
| C55 | 290-0519-00 | | | CAP.FKD.ELECTUT:100UF,20%,20V | 90201 | T0C10761020W1CWL D |
| C81 | 290-0517-00 | B0101000 | B0102011 | CAP.FKD.ELECTUT:6.8UF,20%,35V (PS501, PS501-1 ONLY) | 56289 | 19D168X0095KAR A1 |
| C81 | 283-0111-00 | B0102022 | | CAP.FKD.CEERD1:0.1UF,20%,50V (PS501, PS501-1 ONLY) | 56289 | 273C11 |
| C81 | 283-0111-00 | | | CAP.FKD.CEERD1:0.1UF,20%,50V (PS501-2 ONLY) | 56289 | 273C11 |
| CR10 | 152-0488-00 | | | SEMICONDN DEVICE SILICON,200V,1500MA | 04713 | SDA3177 |
| CR20 | 152-0488-00 | | | SEMICONDN DEVICE SILICON,200V,1500MA | 04713 | SDA3177 |
| CR40 | 152-0141-02 | | | SEMICONDN DEVICE SILICON,90V,50MA | 01295 | 1N4158R |
| CR55 | 152-0066-00 | | | SEMICONDN DEVICE SILICON,400V,750MA | 14433 | LG4016 |
| CR66 | 152-0141-02 | | | SEMICONDN DEVICE SILICON,90V,50MA | 01295 | 1N4158R |
| CR70 | 150-0001-01 | B0101000 | B0299999 | LAMP,LED,RED,2V,100MA | 50434 | HLMF-32000 |
| CR70 | 150-0001-00 | B0300000 | | LT EMITTING DIODE,RED,660NM,100MA,MAX X | 50522 | MV5024 |
| CR71 | 152-0141-02 | | | SEMICONDN DEVICE SILICON,90V,50MA | 01295 | 1N4158R |
| CR74 | 152-0141-02 | | | SEMICONDN DEVICE SILICON,90V,50MA | 01295 | 1N4158R |
| DS70 | 150-0107-00 | B0101000 | B0515569 | LAMP,INCAND,12V,0.04A,T:1 (PS501-1 ONLY) | 87034 | 227AS25 |
| DS70 | 150-0109-00 | B0515700 | | LAMP,INCAND,12V,0.04A,T:1 (PS501-1 ONLY) | 71744 | CM7220 |
| DS70 | 150-0107-00 | B0101000 | B0411139 | LAMP,INCAND,12V,0.04A,T:1 (PS501-2 ONLY) | 87034 | 227AS25 |
| DS70 | 150-0109-00 | B0411140 | | LAMP,INCAND,12V,0.04A,T:1 (PS501-2 ONLY) | 71744 | CM7220 |

Replaceable Electrical Parts—PS 501 (-1, -2)

| Ckt No. | Teletronics Part No. | Serial/Model No. Eff | Discont | Name & Description | Mfr Code | Mfr Part Number |
|---------|----------------------|----------------------|----------|--|----------|------------------|
| J5 | 129-0064-01 | | | POST, BDDGLE, EQ: RED, 55WAX MINIA TURRE | 58474 | A207799-G22 |
| J6 | 129-0064-02 | | | POST, BDDGLE, EQ: WHITE, 55WAX MINIA TURRE | 58474 | 207794-G85 |
| J50 | 129-0064-01 | | | POST, BDDGLE, EQ: RED, 55WAX MINIA TURRE | 58474 | A207799-G22 |
| J52 | 129-0064-00 | | | POST, BDDGLE, EQ: BAROCALIS, 55WAX MINIA TURRE | 58474 | A207799-G37 |
| M55 | 149-0036-00 | | | AMMETER: EQ: 1 MA, 77 OHM, +/-10% (PS501-2 ONLY) | 33005 | MODEL BMT |
| Q100 | 151-0188-00 | | | TRANSISTOR SILICON PNP | 04713 | SPS8886K |
| Q50 | 151-0190-00 | | | TRANSISTOR SILICON PNP | 07283 | S032677 |
| Q60 | 151-0188-00 | | | TRANSISTOR SILICON PNP | 04713 | SPS8886K |
| R3 | 315-0201-00 | | | RES: F, FOX, CMR: 200 OHM, 5%, 0.25W | 01121 | CB20155 |
| R11 | 315-0472-00 | | | RES: F, FOX, CMR: 4.7K OHM, 5%, 0.25W | 01121 | CB4725 |
| R12 | 315-0823-00 | | | RES: F, FOX, CMR: 82K OHM, 5%, 0.25W | 01121 | CB8235 |
| R13 | 315-0102-00 | | | RES: F, FOX, CMR: 10K OHM, 5%, 0.25W | 01121 | CB1025 |
| R14 | 315-0820-00 | | | RES: F, FOX, CMR: 82 OHM, 5%, 0.25W | 01121 | CB8205 |
| R188 | 311-1120-00 | | | RES: VAR, NONWIR: 100 OHM, 30%, 0.25W | 71460 | 201-YA5531 |
| R199 | 301-0471-00 | | | RES: F, FOX, CMR: 470 OHM, 5%, 0.50W | 01121 | EB4715 |
| R266 | 303-0751-00 | | | RES: F, FOX, CMR: 750 OHM, 5%, 1W | 01121 | GB75155 |
| R365 | 315-0103-00 | | | RES: F, FOX, CMR: 10K OHM, 5%, 0.25W | 01121 | CB1035 |
| R388 | 311-1363-00 | | | RES: VAR, NONWIR: 100 OHM, 5%, 0.25W | 71460 | 201-YA5533 |
| R399 | 315-0474-00 | | | RES: F, FOX, CMR: 470K OHM, 5%, 0.25W | 01121 | CB4745 |
| R41 | 315-0103-00 | | | RES: F, FOX, CMR: 10K OHM, 5%, 0.25W | 01121 | CB1035 |
| R42 | 311-1343-00 | | | RES: VAR, NONWIR: 20K X 50 OHM, 0.5W (PS501, PS501-2 ONLY) | 01121 | 10M791 |
| R42 | 311-1341-00 | | | RES: VAR, NONWIR: 10K OHM, 5%, 0.25W | 01121 | 534-9808103J |
| R42 | 311-1120-00 | B0101000 | B0526499 | (PS501-1 ONLY) RES: VAR, NONWIR: 100 OHM, 30%, 0.25W | 71460 | 201-YA5531 |
| R42 | 311-1124-00 | B0526690 | | (PS501-1 ONLY) RES: VAR, NONWIR: 100 OHM, 30%, 0.25W | 71460 | 201-YA5533 |
| R42 | 321-0206-00 | | | RES: FXD, FILM: 0.33K OHM, 1%, 0.125W | 91637 | MFF18166831906OF |
| R44 | 311-1264-00 | | | (PS501-1 ONLY) RES: VAR, NONWIR: 1.5K OHM, 10%, 0.50W | 32997 | 3329P-L58-152 |
| R45 | 301-0302-00 | | | (PS501-1 ONLY) RES: F, FOX, CMR: 30K OHM, 5%, 0.50W | 01121 | EB3025 |
| R52 | 315-0510-00 | | | RES: F, FOX, CMR: 510 OHM, 5%, 0.25W | 01121 | CB5105 |
| R53 | 315-0301-00 | | | RES: F, FOX, CMR: 300 OHM, 5%, 0.25W | 01121 | CB3015 |
| R54 | 315-0512-00 | | | RES: F, FOX, CMR: 51K OHM, 5%, 0.25W | 01121 | CB5125 |
| R55 | 308-0240-00 | | | RES: F, FOX, VVW: 0.25W | 91637 | R52B-D20000J |
| R56 | 308-0751-00 | | | RES: F, FOX, VVW: 0.175 OHM, 5%, 1W | 80009 | 308-A751-000 |
| R56 | 321-0318-00 | | | (PS501-2 ONLY) RES: FXD, FILM: 20K OHM, 1%, 0.025W | 91637 | MFF18166820061F |
| R57 | 315-0471-00 | | | (PS501-2 ONLY) | | |
| R61 | 315-0154-00 | | | RES: F, FOX, CMR: 15K OHM, 5%, 0.25W | 01121 | CB1545 |
| R63 | 311-1311-00 | B0101000 | B0199999 | RES: F, FOX, CMR: 150K OHM, 5%, 0.25W | 01121 | 73M460484102M02M |
| R65 | 311-1389-00 | B0200000 | 056209 | RES: VAR, NONWIR: 1K OHM, 20%, 1W (PS501, PS501-1 ONLY) | 01121 | 12MR837 |
| R65 | 311-1095-00 | B0562100 | | RES: VAR, NONWIR: 10K OHM, 20%, 0.50W (PS501, PS501-1 ONLY) | 12697 | 382-CM40386 |
| R65 | 311-1369-00 | | | RES: VAR, NONWIR: 1K OHM, 1W W (PS501-2 ONLY) | 01121 | 12MR837 |
| R65 | 321-0193-07 | B0562100 | | RES: FXD, FILM: 1K OHM, 1%, 0.125W (PS501-1 ONLY) | 91637 | MFF181668100008 |
| R66 | | | | | | |

Replaceable Electrical Parts—PS 501 (-1, -2)

| Ckt No | Tektronix Part No | Serial/Model No Eff Dscont | Name & Description | Mfr Code | Mfr Part Number |
|--------|-------------------|-------------------------------|--|----------|------------------|
| R68 | 315-0104-00 | | RESS FXCD, METAL FILM 100K OHM, 5% 0.25W | 01121 | CB10145 |
| R74 | 315-0511-00 | | RESS FXCD, METAL FILM 510 OHM, 5% 0.25W | 01121 | CB51115 |
| R76 | 315-0122-00 | B0101000 | RESS FXCD, METAL FILM 2K OHM, 5% 0.25W | 01121 | CB12255 |
| R76 | ----- | | (PS501-1 ONLY) | | |
| R76 | 301-0122-00 | B0518700 | RESS FXCD, METAL FILM 2K OHM, 5% 0.50W | 01121 | EB12235 |
| R76 | ----- | | (PS501-1 ONLY) | | |
| R76 | 315-0122-00 | B0101000 | RESS FXCD, METAL FILM 2K OHM, 5% 0.25W | 01121 | CB12255 |
| R76 | ----- | | (PS501-2 ONLY) | | |
| R76 | 301-0122-00 | B04111400 | RESS FXCD, METAL FILM 2K OHM, 5% 0.50W | 01121 | EB12255 |
| R76 | ----- | | (PS501-2 ONLY) | | |
| R81 | 321-0201-00 | | RESS FXD, FILM: 1.22K OHM, 1%, 0.102W | 91637 | MFF183660212010F |
| R83 | 321-0166-00 | | RESS FXD, FILM: 523 OHM, 1%, 0.125W | 91637 | MFF183660232010F |
| R83 | ----- | | (PS501, PS501-2 ONLY) | | |
| R83 | 321-0191-00 | B0101000 | RESS FXD, FILM: 953 OHM, 1%, 0.125W | 91637 | MFF183660232010F |
| R83 | ----- | | (PS501-2 ONLY) | | |
| R83 | 321-0188-00 | B0526580 | RESS FXD, FILM: 887 OHM, 1%, 0.125W | 91637 | MFF183660232010F |
| R83 | ----- | | (PS501-1 ONLY) | | |
| S10 | 260-1209-00 | | SWITCH, PUSHBUTTON, 1A, 250VDC | 31918 | 601347 |
| S42 | 260-1209-00 | | SWITCH, PUSHBUTTON, 1A, 250VDC | 31918 | 601347 |
| S42 | ----- | | (PS501-1 ONLY) | | |
| S55 | 260-1445-00 | | SWITCH, PUSHBUTTON, 5A, 250VDC | 80009 | 260-1445-00 |
| S55 | ----- | | (PS501-2 ONLY) | | |
| U2 | 156-0176-00 | | MICROCIRCUIT, 1.5V REGULATOR | 07283 | UA390K0KC |
| U40 | 156-0067-00 | B0101000 | MICROCIRCUIT, OPERATIONAL AMPLIFIER | 01295 | MICR067470P CP |
| U40 | ----- | | (PS501 ONLY) | | |
| U40 | 156-0067-06 | B0101999 | MICROCIRCUIT, OPERATIONAL AMPLIFIER | 02735 | CA741GJG |
| U40 | ----- | | (PS501 ONLY) | | |
| U40 | 156-0067-06 | B0101000 | MICROCIRCUIT, OPERATIONAL AMPLIFIER | 02735 | CA741GJG |
| U40 | ----- | | (PS501-1 ONLY) | | |
| U40 | 156-0067-06 | B0101888 | MICROCIRCUIT, OPERATIONAL AMPLIFIER | 02735 | CA741GJG |
| U40 | ----- | | (PS501-1 ONLY) | | |
| U40 | 156-0067-06 | | MICROCIRCUIT, OPERATIONAL AMPLIFIER | 02735 | CA741GJG |
| U40 | ----- | | (PS501-2 ONLY) | | |
| U70 | 156-0067-00 | B0101000 | MICROCIRCUIT, OPERATIONAL AMPLIFIER | 01295 | MICR067470P CP |
| U70 | ----- | | (PS501 ONLY) | | |
| U70 | 156-0067-06 | B0101999 | MICROCIRCUIT, OPERATIONAL AMPLIFIER | 02735 | CA741GJG |
| U70 | ----- | | (PS501 ONLY) | | |
| U70 | 156-0067-00 | B0101000 | MICROCIRCUIT, OPERATIONAL AMPLIFIER | 01295 | MICR067470P CP |
| U70 | ----- | | (PS501-1 ONLY) | | |
| U70 | 156-0067-06 | B0101888 | MICROCIRCUIT, OPERATIONAL AMPLIFIER | 02735 | CA741GJG |
| U70 | ----- | | (PS501-1 ONLY) | | |
| U70 | 156-0067-06 | | MICROCIRCUIT, OPERATIONAL AMPLIFIER | 02735 | CA741GJG |
| U70 | ----- | | (PS501-2 ONLY) | | |
| VR10 | 152-0461-00 | | SEMICONDUCTOR DEVICE ZENER, 0.4W, 6.2V, 5% | 047183 | SZ625000K2 |
| VR10 | ----- | | (PS501, PS501-2 ONLY) | | |
| VR10 | 152-0212-00 | | SEMICONDUCTOR DEVICE ZENER, 0.5W, 9.1V, 5% | 047113 | SZ50648RRL |
| VR10 | ----- | | (PS501-1 ONLY) | | |
| VR11 | 152-0212-00 | | SEMICONDUCTOR DEVICE ZENER, 0.5W, 9.1V, 5% | 047113 | SZ50648RRL |
| VR19 | 152-0304-00 | | SEMICONDUCTOR DEVICE ZENER, 0.4W, 200V, 5% | 15238 | Z5411 |
| VR26 | 152-0279-00 | | SEMICONDUCTOR DEVICE ZENER, 0.4W, 5.1V, 5% | 047183 | SZ635000RRL |

DIAGRAMS AND CIRCUIT BOARD ILLUSTRATIONS

Symbols

Graphic symbols and class designation letters are based on ANSI Standard Y32.2-1975.

Logic symbology is based on ANSI Y32.14-1973 in terms of positive logic. Logic symbols depict the logic function performed and may differ from the manufacturer's data.

The overline on a signal name indicates that the signal performs its intended function when it is in the low state.

Abbreviations are based on ANSI Y1.1-1972.

Other ANSI standards that are used in the preparation of diagrams by Tektronix, Inc. are:

- Y14.15, 1966 Drafting Practices.
- Y14.2, 1973 Line Conventions and Lettering.
- Y10.5, 1968 Letter Symbols for Quantities Used in Electrical Science and Electrical Engineering.

American National Standard Institute
1430 Broadway
New York, New York 10018

Component Values

Electrical components shown on the diagrams are in the following units unless noted otherwise:

- Capacitors = Values one or greater are in picofarads (pF). Values less than one are in microfarads (μ F).
- Resistors = Ohms (Ω).

The information and special symbols below may appear in this manual:

Assembly Numbers and Grid Coordinates

Each assembly in the instrument is assigned an assembly number (e.g., A20). The assembly number appears on the circuit board outline on the diagram, in the title for the circuit board component location illustration, and in the lookup table for the schematic diagram and corresponding component locator illustration. The Replaceable Electrical Parts list is arranged by assemblies in numerical sequence; the components are listed by component number* (see following illustration for constructing a component number).

The schematic diagram and circuit board component location illustration have grids. A lookup table with the grid coordinates is provided for ease of locating the component. Only the components illustrated on the facing diagram are listed in the lookup table. When more than one schematic diagram is used to illustrate the circuitry on a circuit board, the circuit board illustration may only appear opposite the first diagram on which it was illustrated; the lookup table will list the diagram number of other diagrams that the circuitry of the circuit board appears on.

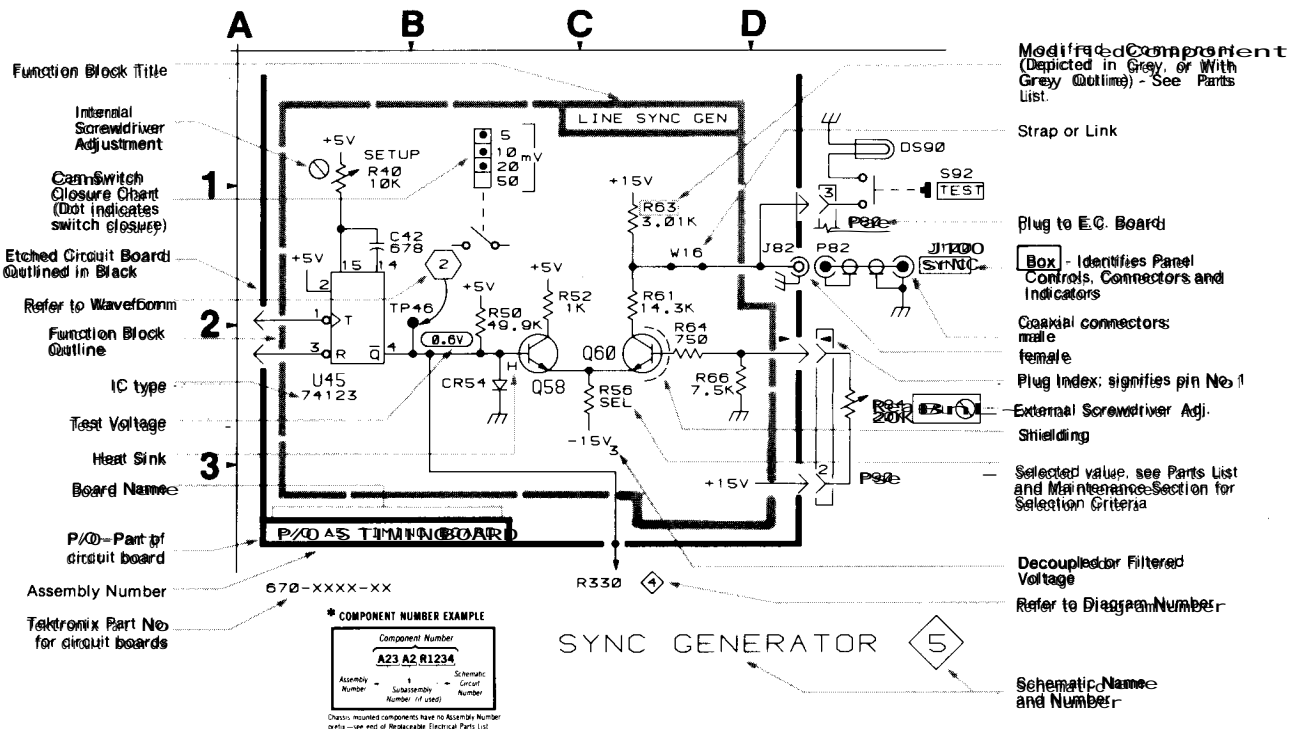

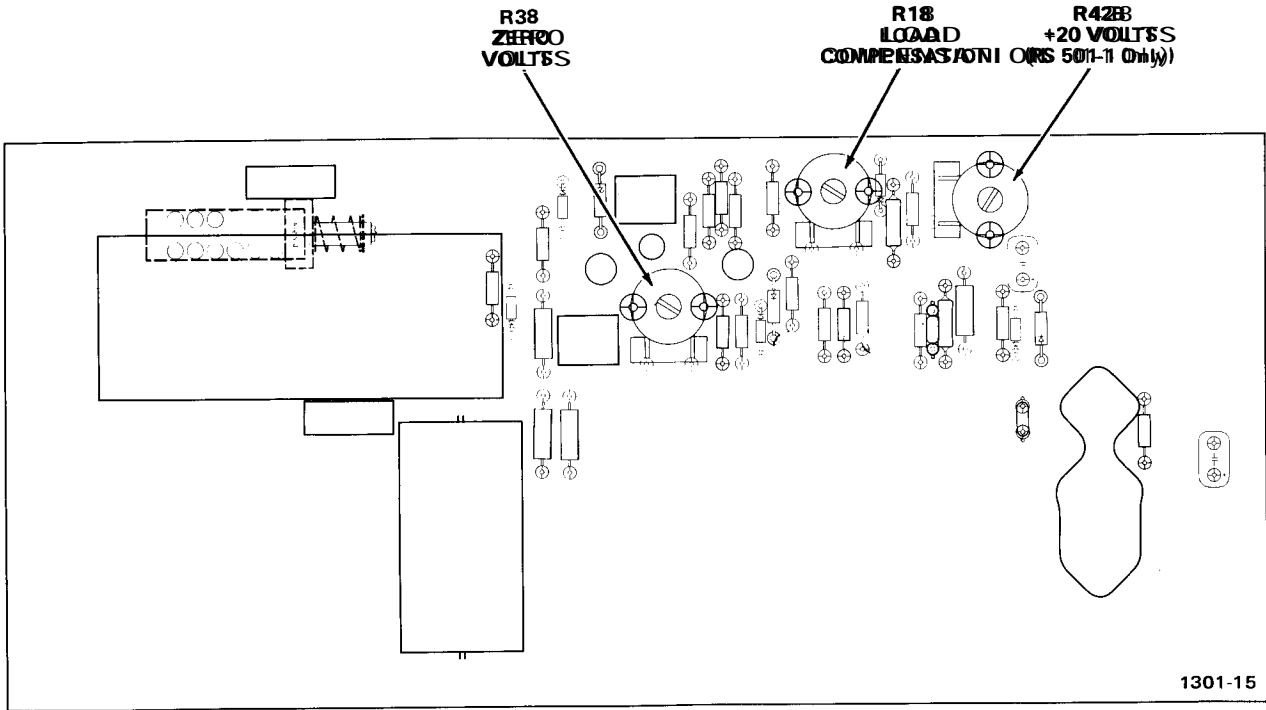

INTERNAL ADJUSTMENTS

 **Static Sensitive Devices**
See Maintenance Section

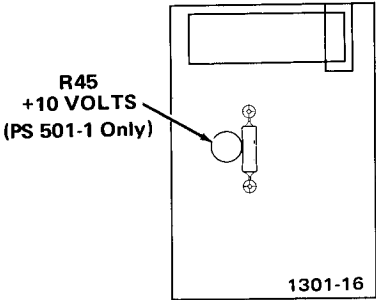

Fig. 8-1. Internal adjustments.

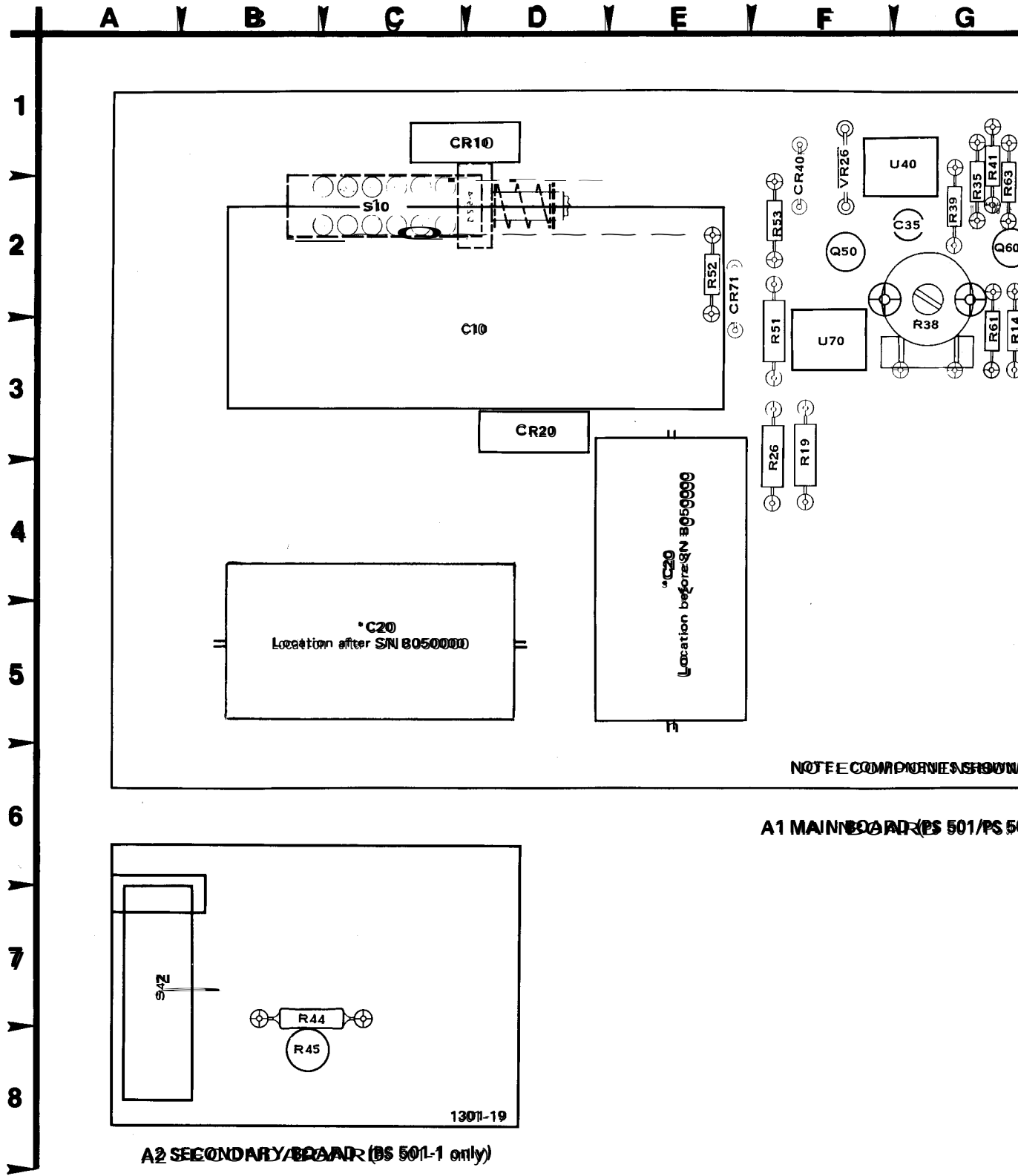
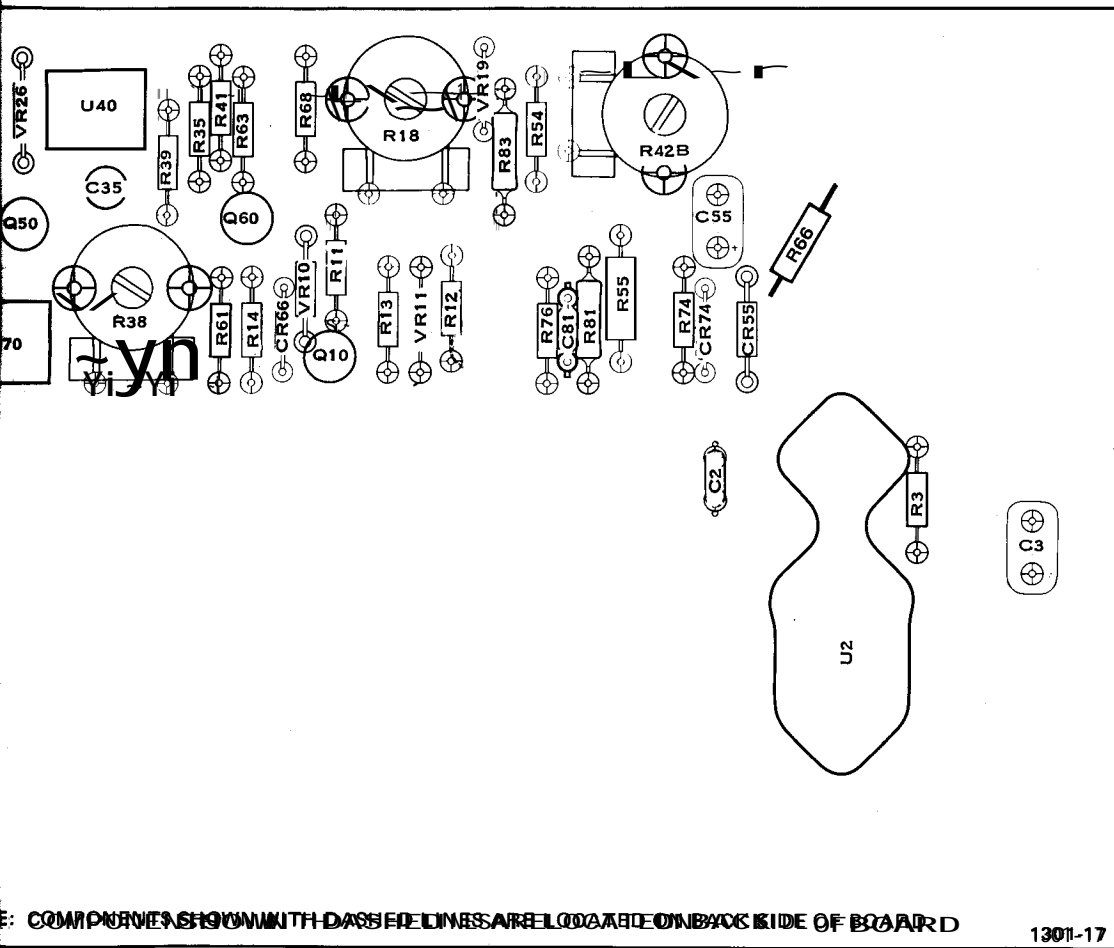

Fig. 8-2. PS 501/PS 501-1 Component Locations

V G V H V J V K V L V M V



COMPONENTS SHOWN WITH DASHED LINES ARE LOCATED ON BACK SIDE OF BOARD

1301-17

PS 501/PS 501-1)

Static Sensitive Devices
See Maintenance Section

PS 501/PS 501-1 Component Locations.

REV MAY 1983

COMPONENT LOCATIONS

| A1 ASSY (PS 501/PS 501-1) | | | POWER SUPPLY  | | |
|---------------------------|--------------------|----------------|--|--------------------|----------------|
| Circuit Number | Schematic Location | Board Location | Circuit Number | Schematic Location | Board Location |
| C2 | B11 | K3 | R35 | F4 | G2 |
| C3 | C1 | L3 | R38 | D5 | G3 |
| C10 | C2 | D3 | R39 | E5 | G2 |
| C20 | C6 | C5 | R41 | F5 | G1 |
| C35 | F5 | G2 | R42A | F4 | |
| C55 | J7 | K2 | R42B* | E7 | J2 |
| C81 | F7 | J3 | R51 | G5 | F3 |
| CR100 | B2 | D1 | R52 | K5 | E2 |
| CR200 | B6 | D3 | R53 | K5 | F2 |
| CR400 | G5 | F2 | R54 | K5 | J2 |
| CR55 | J7 | K2 | R55 | K7 | J2 |
| CR66 | H5 | H3 | R61 | J5 | G3 |
| CR700 | G5 | | R63 | J5 | G2 |
| CR71 | G5 | E2 | R66a* | K6 | K2 |
| CR74 | H7 | K3 | R68 | H6 | H2 |
| DIS70* | F7 | | R74 | G7 | K3 |
| Q10 | D2 | H3 | R76* | G7 | J3 |
| Q50 | K5 | F2 | R81 | F7 | J2 |
| Q60 | J5 | G2 | R83 | E7 | J2 |
| R3 | C1 | L3 | S10 | B7 | C2 |
| R11 | C2 | H3 | U2 | B1 | L4 |
| R12 | D2 | H2 | U40 | F5 | G1 |
| R13 | D2 | H3 | U70 | G6 | F3 |
| R14 | D2 | G3 | VR10 | D4 | H2 |
| R18 | D7 | H2 | VR11 | D2 | H3 |
| R19 | D6 | F3 | VR19 | D6 | J1 |
| R26 | D6 | F3 | VR26 | D6 | F1 |

| A2 ASSY (PS 501-1 only) | | | POWER SUPPLY  | | |
|-------------------------|--------------------|----------------|--|--------------------|----------------|
| Circuit Number | Schematic Location | Board Location | Circuit Number | Schematic Location | Board Location |
| R44 | F3 | B7 | S42 | F4 | B7 |
| R45 | F3 | B8 | | | |

* PS 501-1 only.

* See Parts List for serial number ranges.

A1 ASSY (PS 501-2 only)

POWER SUPPLY

1

| Circuit Number | Schematic Location | Board Location | Circuit Number | Schematic Location | Board Location |
|----------------|--------------------|----------------|----------------|--------------------|----------------|
| C2 | B1 | K4 | R35 | F4 | H2 |
| C3 | C1 | K4 | R38 | D5 | G3 |
| C10 | C2 | C2 | R39 | D5 | G2 |
| C200 | C6 | E5 | R41 | F5 | H2 |
| C35 | F5 | G2 | R42A | F4 | |
| C55 | J7 | K2 | R51 | G5 | F3 |
| C81 | F7 | K3 | R52 | K5 | E2 |
| CR100 | C2 | D4 | R53 | K5 | F2 |
| CR200 | B6 | D6 | R54 | K5 | J2 |
| CR400 | G5 | D2 | R55 | K7 | K3 |
| CR555 | J7 | L3 | R56 | J8 | J4 |
| CR66 | H5 | H3 | R57 | H8 | K4 |
| CR71 | G5 | F3 | R61 | J5 | H3 |
| CR744 | G6 | K3 | R63 | J5 | H2 |
| DS70 | F7 | | R68 | H6 | H2 |
| M55 | G8 | | R74 | G7 | K3 |
| Q10 | D2 | H3 | R76 | G7 | J3 |
| Q50 | K4 | F2 | R81 | F7 | K3 |
| Q60 | J5 | H2 | R83 | E7 | J2 |
| R3 | C1 | M4 | S10 | B7 | C5 |
| R11 | C2 | H2 | S55 | H8 | H5 |
| R13 | D2 | J3 | U2 | B1 | L5 |
| R14 | D2 | J3 | U40 | F5 | G2 |
| R18 | D7 | H3 | U70 | G6 | F3 |
| R19 | D6 | J2 | VR10 | D4 | H3 |
| R26 | D6 | F4 | VR11 | D2 | J3 |
| | | F4 | VR19 | D6 | J1 |
| | | | VR26 | D6 | F2 |

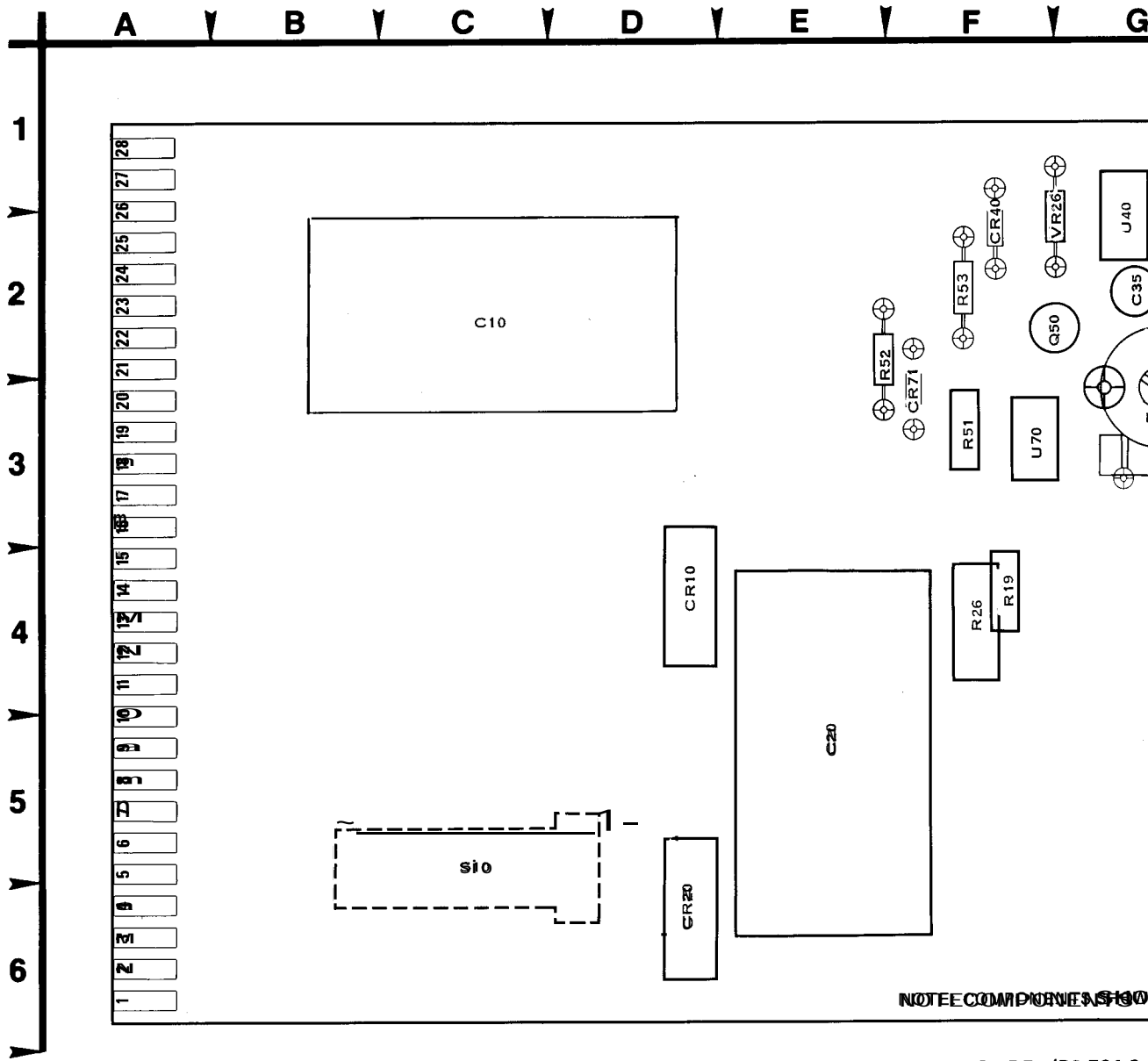

A1 MAIN BOARD (PS 501-2)

F V G V H V J V K V L V M V

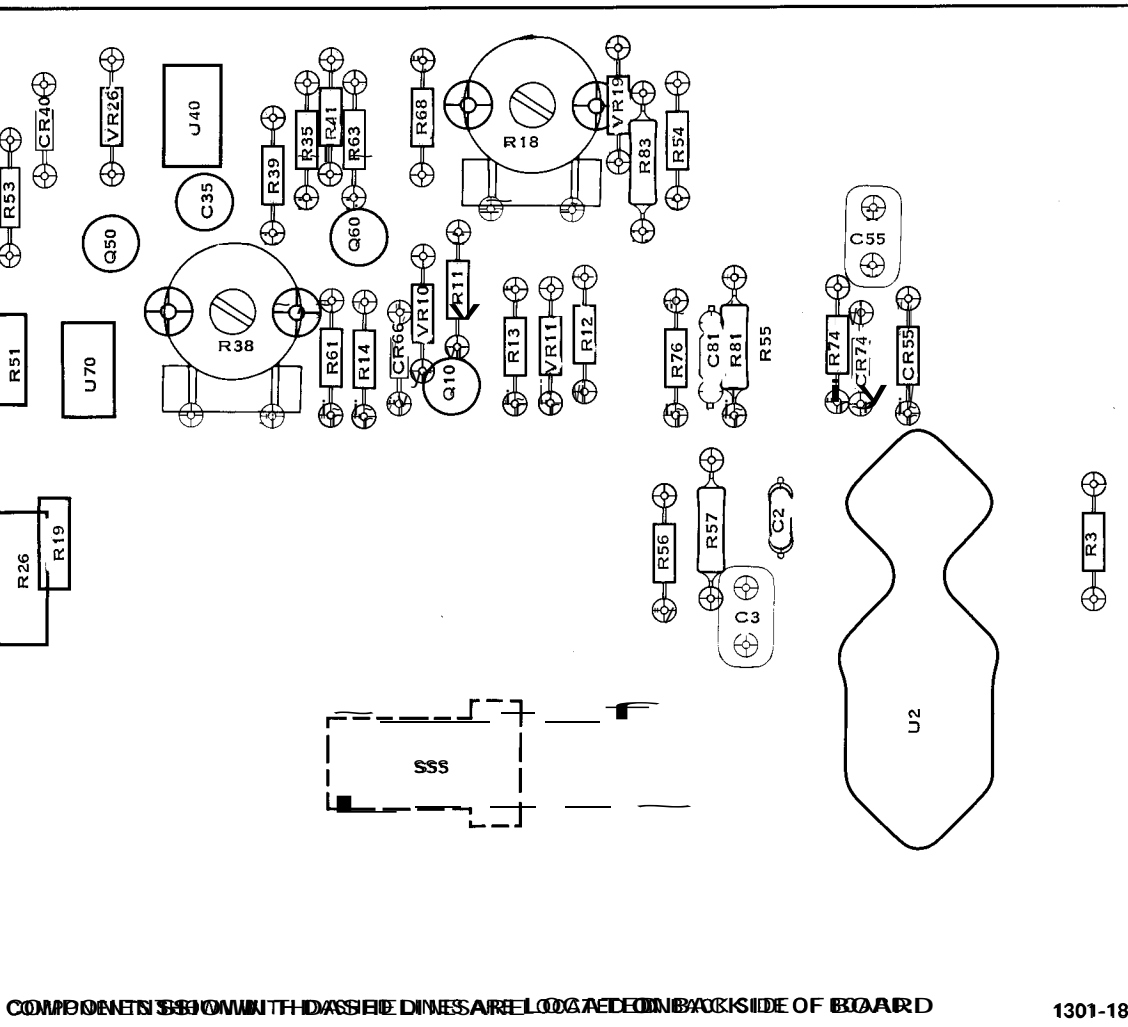

PS 501-2 COMPONENT LOCATIONS

BOARD (PS 501-2 only)

Static Sensitive Devices
 See Maintenance Section

F G H J K L

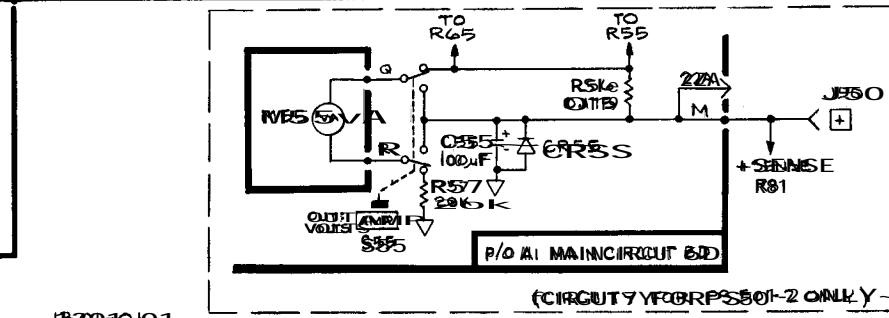
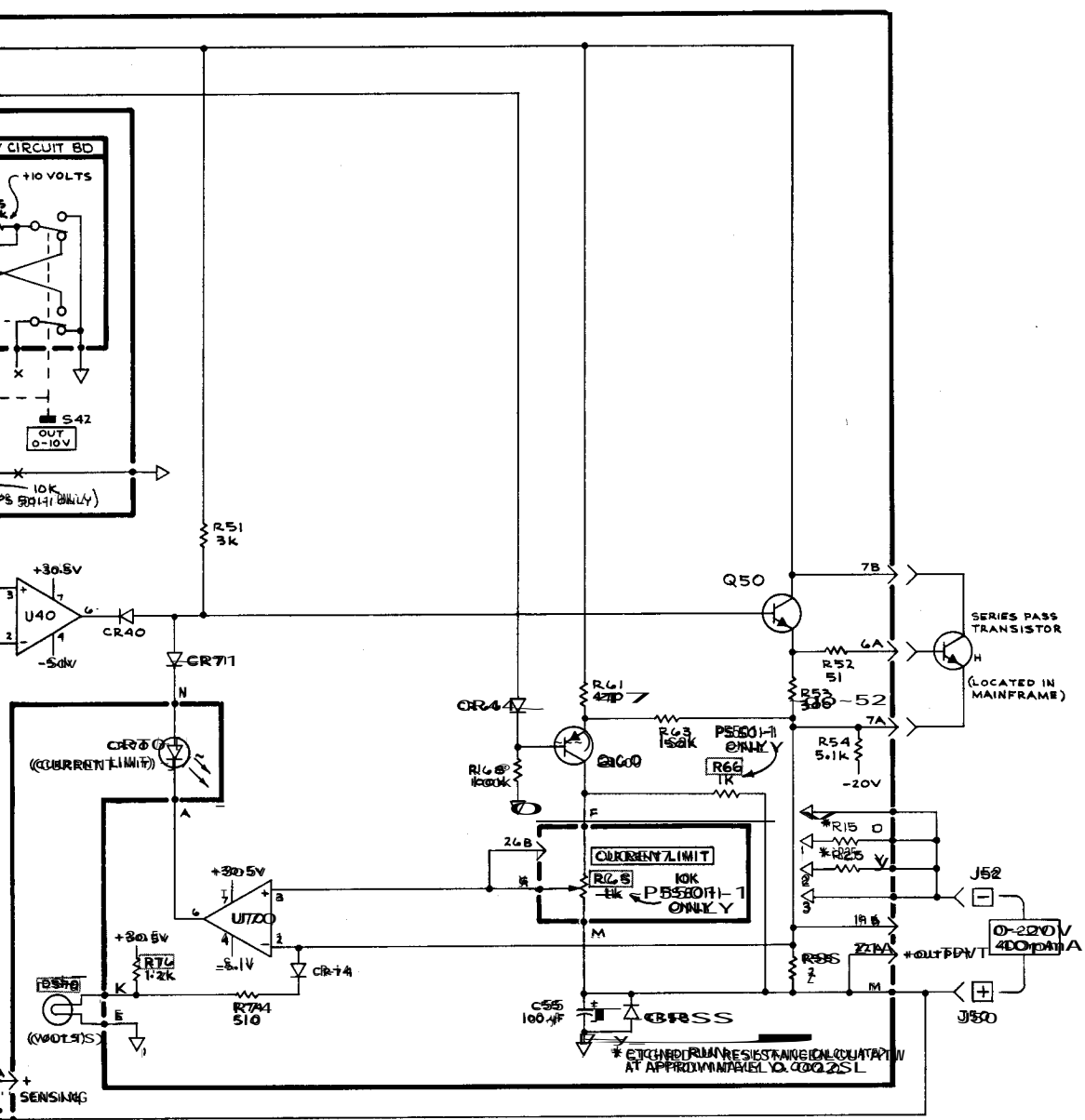

Static Sensitive Devices
See Maintenance Section

1530-10-101
REV 10/11/83

POWER SUPPLY

DEH
2373

POWER SUPPLY

1

REPLACEABLE MECHANICAL PARTS

PARTS ORDERING INFORMATION

Replacement parts are available from or through your local Tektronix, Inc. Field Office or representative.

Changes to Tektronix instruments are sometimes made to accommodate improved components as they become available, and to give you the benefit of the latest circuit improvements developed in our engineering department. It is therefore important, when ordering parts, to include the following information in your order: Part number, instrument type or number, serial number, and modification number if applicable.

If a part you have ordered has been replaced with a newer improved part, your local Tektronix, Inc. Field Office or representative will contact you concerning any change in part number.

Change information, if any, is located at the rear of this manual.

SPECIAL NOTES AND SYMBOLS

- X000 Part first added at this serial number
- 00X Part removed after this serial number

FIGURE AND INDEX NUMBERS

Items in this section are referenced by figure and index numbers to the illustrations.

INDENTATION SYSTEM

This mechanical parts list is indented to indicate item relationships. Following is an example of the indentation system used in the description column:

- ```

1 2 3 4 5 Name & Description

Assembly and/or Component
Attaching parts for Assembly and/or Component
 ---*---
Detail Part of Assembly and/or Component
Attaching parts for Detail Part
 ---*---
Parts of Detail Part
Attaching parts for Parts of Detail Part
 ---*---

```

Attaching Parts always appear in the same indentation as the item it mounts, while the detail parts are indented to the right. Indented items are part of, and included with, the next higher indentation. The separation symbol---\*--- indicates the end of attaching parts.

Attaching parts must be purchased separately, unless otherwise specified.

## ITEM NAME

In the Parts List, an Item Name is separated from the description by a colon (:). Because of space limitations, an Item Name may sometimes appear as incomplete. For further Item Name identification, the U.S. Federal Cataloging Handbook H-1 can be utilized where possible.

## ABBREVIATIONS

|        |                    |         |                       |         |                      |          |                 |
|--------|--------------------|---------|-----------------------|---------|----------------------|----------|-----------------|
| "      | INCH               | ELECTRN | ELECTRON              | IN      | INCH                 | SE       | SINGLE END      |
| N      | NUMBER             | ELEC    | ELECTRICAL            | INCOND  | INSULATION           | SECT     | SECTION         |
| ACTFR  | ACTUATOR           | ELCTLT  | ELECTROLYTIC          | INSUL   | INSULATOR            | SEMICOND | SEMICONDUCTOR   |
| ADPTR  | ADAPTER            | ELEM    | ELEMENT               | INTL    | INTERNAL             | SHLD     | SHIELD          |
| ALIGN  | ALIGNMENT          | EPL     | ELECTRICAL PARTS LIST | LPHDR   | LAMP HOLDER          | SHDR     | SHROUDED        |
| AL     | ALUMINUM           | EQPT    | EQUIPMENT             | MACH    | MACHINE              | SKT      | SOCKET          |
| ASSEMB | ASSEMBLED          | EXT     | EXTERNAL              | MECH    | MECHANICAL           | SL       | SLIDE           |
| ASSY   | ASSEMBLY           | FIL     | FILAMENT HEAD         | MTEG    | MOUNTING             | SLFKNG   | SELF-Locking    |
| ATTEN  | ATTENUATOR         | FLEX    | FLEXIBLE              | NIP     | NIPPLE               | SLVNG    | SLEEVING        |
| AWG    | AMERICAN WIRE GAGE | FLH     | FLAT HEAD             | NONWIRE | NONWIRE WOUND        | SFA      | SPRING          |
| BD     | BOARD              | FLTR    | FILTER                | ORD     | ORDER BY DESCRIPTION | SO       | SQUARE          |
| BRKT   | BRACKET            | FR      | FRAMING FRONT         | OD      | OUTSIDE DIAMETER     | SST      | STAINLESS STEEL |
| BRSS   | BRASS              | FSTNR   | FASTENER              | OVH     | OVERHEAD             | STL      | STEEL           |
| BRZ    | BRONZE             | FT      | FOOT                  | PH BRZ  | PHOSPHOR BRONZE      | SW       | SWITCH          |
| BUSHG  | BUSHING            | FXD     | FIXED                 | PL      | PLAIN or PLATE       | T        | TUBE            |
| CAB    | CABINET            | GSKT    | GASKET                | PLSTC   | PLASTIC              | TERM     | TERMINAL        |
| CAP    | CAPACITOR          | HDL     | HANDLE                | PN      | PART NUMBER          | THRD     | THREAD          |
| CER    | CERAMIC            | HEX     | HEXAGON               | PNH     | PAN HEAD             | THK      | THICK           |
| CHASS  | CHASSIS            | HEXHD   | HEXAGON HEAD          | PWR     | POWER                | TNSN     | TENSION         |
| CKT    | CIRCUIT            | HEXSOC  | HEXAGON SOCKET        | ROFT    | RECTIFIABLE          | TRG      | TAPPING         |
| COMP   | COMPOSITION        | HLCPS   | HELICAL COMPRESSION   | RES     | RESISTOR             | TRH      | TRUSS HEAD      |
| CONN   | CONNECTOR          | HLEXT   | HELICAL EXTENSION     | RIGD    | RIGID                | V        | VOLTAGE         |
| COV    | COVER              | HV      | HIGH VOLTAGE          | RLF     | RELIEF               | VAR      | VARIABLE        |
| CPUG   | COUPLING           | IC      | INTEGRATED CIRCUIT    | RTNR    | RETAINER             | W/       | WITH            |
| CRT    | CATHODE RAY TUBE   | ID      | INSIDE DIAMETER       | SOH     | SOCKET HEAD          | WSHR     | WASHER          |
| DEG    | DEGREE             | IDENT   | IDENTIFICATION        | SCOPE   | OSCILLOSCOPE         | XFRM     | TRANSFORMER     |
| DWR    | DRAWER             | IMPLR   | IMPELLER              | SCR     | SCREW                | XSTR     | TRANSISTOR      |

CROSS INDEX—MFR. CODE NUMBER TO MANUFACTURER

| Mfr. Code | Manufacturer                          | Address              | City, State, Zip         |
|-----------|---------------------------------------|----------------------|--------------------------|
| 00900Y    | NORTHWEST EASTERN SALES, INC          | 7923 SW CIRROS DRIVE | BEAVERTON, OR 97005      |
| 00779     | AMP, INC                              | P O BOX 3608         | HARRISBURG, PA 17105     |
| 09922     | BURNING CORPORATION ON                | RICHARDS AVENUE      | NORWALK, CT 06852        |
| 12327     | FREEMAN CORPORATION ON                | 9301 ALLEN DRIVE     | CLEVELAND, OH 44125      |
| 22528     | BRUCE ELECTRONICS, INC                | YONGE EXPRESSWAY     | NEW QUENEBEAND, NH 17070 |
| 33005     | JEWELL ELECTRIC AND INSTRUMENTS INC   | GREENFIELD           | MANCHESTER, NH 03105     |
| 45722     | URBONOR PARKER KALON ENSTEIN DIV      |                      | CAMPBELLVILLE, KY 42718  |
| 58474     | SUPERIOR ELECTRIC COO                 | 383 MIDDLE ST.       | BRISTOL, CT 06010        |
| 70276     | ALLEN MFG COO                         | P O DRAWERS          | HARTFORD, CT 06101       |
| 73743     | FISHER SPECIAL MFG COO                | 446 MORRIS ST        | CINCINNATI, OH 45206     |
| 73803     | TEXAS INSTRUMENTS, INC, METALLURGICAL |                      |                          |
|           | MATERIALS DIV                         | 34 FOREST STREET     | ATTLEBORO, MA 02708      |
| 78189     | ILLINOIS TOOL WORKS INC               |                      |                          |
|           | SHAKER PROVISION                      | ST. CHARLES ROAD     | ELGIN, IL 60120          |
| 79807     | WRIGHT MACHINERY COO                  | 2100 S. O BAY ST.    | MILWAUKEE, WI 53207      |
| 80009     | TEKTRONIX, INC                        | P O BOX 600          | BEAVERTON, OR 97077      |
| 83330     | SMITH, HERMAN H INC                   | 812 SNEED HERE AVE   | BROOKLYN, NY 11207       |
| 83385     | CENTRAL SOLENOID                      | 2530 CRESSENT DR     | BROADWAY, NY 00158       |
| 86928     | SEATERON MFG COMPANY, INC             | 701 SONORA AVENUE E  | GLENDALE, CA 91201       |
| 93907     | TEXTRONIC COMPANY                     | 800 18TH AVE         | ROCKFORD, IL 61101       |



Digitally signed by  
<http://www.aa4bff.com>

| Fig. & Index No. | Tektronix Part No. | Serial/Model No. |         | Qty | 1 | 2 | 3 | 4 | 5 | Name & Description                                                               | Mfr Code | Mfr Part Number    |
|------------------|--------------------|------------------|---------|-----|---|---|---|---|---|----------------------------------------------------------------------------------|----------|--------------------|
|                  |                    | Eff              | Discont |     |   |   |   |   |   |                                                                                  |          |                    |
| -1               | 366-1422-01        | B010100          | B052139 | 1   |   |   |   |   |   | KINDBELATCH<br>(PS501-1, PS501-2 ONLY)                                           | 80009    | 366-1422-01        |
|                  | 366-1690-00        | B052140          |         | 1   |   |   |   |   |   | KINDBESIL GY, 0.53 X 0.23 X 1.059<br>(PS501-1, PS501-2 ONLY)                     | 80009    | 366-1690-00        |
|                  | 214-1880-00        | B010100          | B052139 | 1   |   |   |   |   |   | PINK KINDBESIL 0.094 O.D. X 0.120 INCH LONG<br>(PS501-1, PS501-2 ONLY)           | 80009    | 214-1880-00        |
| -2               | 366-1327-00        |                  |         | 1   |   |   |   |   |   | KINDBGRAY<br>(PS501 ONLY)                                                        | 80009    | 366-1327-00        |
|                  | 213-0153-00        |                  |         | 1   |   |   |   |   |   | .SEESBREW 40 X 0.125, STL BK OXD, HEX                                            | 000CY    | OBD                |
| -3               | 366-1283-00        |                  |         | 1   |   |   |   |   |   | KINDBGRAY<br>(PS501 ONLY)                                                        | 80009    | 366-1283-00        |
|                  | 213-0153-00        |                  |         | 1   |   |   |   |   |   | .SEESBREW 40 X 0.125, STL BK OXD, HEX                                            | 000CY    | OBD                |
| -4               | 366-0494-00        |                  |         | 1   |   |   |   |   |   | KINDBGRAY WITH SEESBREW                                                          | 80009    | 366-0494-00        |
| -5               | 366-1257-74        |                  |         | 1   |   |   |   |   |   | .SEESBREW 40 X 0.125, STL BK OXD, HEX<br>PUSH BUTTONGRAY-CON                     | 80009    | 366-1257-74        |
| -6               | 426-068-1-00       |                  |         | 1   |   |   |   |   |   | FR. RUBB BUTTONGRAY PLASTIC                                                      | 80009    | 426-068-1-00       |
| -8               | 366-1402-00        |                  |         | 1   |   |   |   |   |   | PUSH BUTTONGSIL GY, 10-20V<br>(PS501-1 ONLY)                                     | 80009    | 366-1402-00        |
|                  | 337-1399-00        |                  |         | 2   |   |   |   |   |   | SHLD, ELECTRICIAL SIDE<br>(PS501, PS501-2 ONLY)                                  | 80009    | 337-1399-00        |
|                  | 337-1399-00        | B010100          | B019999 | 2   |   |   |   |   |   | SHLD, ELECTRICIAL SIDE<br>(PS501-1 ONLY)                                         | 80009    | 337-1399-00        |
|                  | 337-1399-00        | B020000          |         | 1   |   |   |   |   |   | SHLD, ELECTRICIAL SIDE<br>(PS501-1 ONLY)                                         | 80009    | 337-1399-00        |
| -9               | 129-0064-01        |                  |         | 2   |   |   |   |   |   | POST, BDG, ELEC RED, 5-WAY MINIATURE<br>***** (ATTACHING PARTS) *****            | 58474    | A207799-G2         |
|                  | 210-0457-00        |                  |         | 1   |   |   |   |   |   | NUT, FLA, SEEWAG-32 X 0.312, STL CD PL                                           | 83385    | OBD                |
|                  | 358-018-1-01       |                  |         | 1   |   |   |   |   |   | INSULATOR BSBGRED<br>***** (END ATTACHING PARTS) *****                           | 58474    | B207516-G2/INSUL   |
| -12              | 129-0064-00        |                  |         | 1   |   |   |   |   |   | POST, BDG, ELEC CHHRCOAL, 5-WAY MINIATURE<br>***** (ATTACHING PARTS) *****       | 58474    | A207799-G7         |
| -13              | 210-0457-00        |                  |         | 1   |   |   |   |   |   | NUT, FLA, SEEWAG-32 X 0.312, STL CD PL                                           | 83385    | OBD                |
| -14              | 358-018-1-00       |                  |         | 1   |   |   |   |   |   | INSULATOR BSBGCHHRCOAL<br>***** (END ATTACHING PARTS) *****                      | 58474    | B207516-G7/INSUL   |
| -15              | 129-0064-02        |                  |         | 1   |   |   |   |   |   | POST, BDG, ELEC WHITE, 5-WAY, MINIATURE                                          | 58474    | 207784-065         |
| -16              |                    |                  |         | 1   |   |   |   |   |   | INSULATOR BSHGWHITE<br>***** (ATTACHING PARTS) *****                             |          |                    |
| -17              | 210-0457-00        |                  |         | 1   |   |   |   |   |   | NUT, FLA, SEEWAG-32 X 0.312, STL CD PL<br>***** (END ATTACHING PARTS) *****      | 83385    | OBD                |
| -18              |                    |                  |         | 1   |   |   |   |   |   | RESISTOR, VAR (SEE R65 REPL)<br>***** (ATTACHING PARTS) *****                    |          |                    |
| -19              | 210-0583-00        |                  |         | 1   |   |   |   |   |   | NUT, PLAIN, HEX: 0.25-32 X 0.312 INCH, BRS                                       | 73743    | 2X20317-4002       |
| -20              | 210-0940-00        |                  |         | 1   |   |   |   |   |   | WASHER, FLAT: 0.25 ID X 0.375 INCH OD, STL                                       | 79807    | OBD                |
|                  | 210-0046-00        |                  |         | 1   |   |   |   |   |   | WASHER, LOCK: 0.261 ID, INT: 0.018 THK, BRS<br>***** (END ATTACHING PARTS) ***** | 78189    | 1214-05-00-03541 C |
| -21              |                    |                  |         | 1   |   |   |   |   |   | RESISTOR, VAR (SEE R42, R42 REPL)<br>(PS501, PS501-2 ONLY)                       |          |                    |
|                  |                    |                  |         | -   |   |   |   |   |   | ***** (ATTACHING PARTS) *****                                                    |          |                    |
| -22              | 210-0583-00        |                  |         | 1   |   |   |   |   |   | NUT, PLAIN, HEX: 0.25-32 X 0.312 INCH, BRS                                       | 73743    | 2X20317-4002       |
| -23              | 210-0940-00        |                  |         | 1   |   |   |   |   |   | WASHER, FLAT: 0.25 ID X 0.375 INCH OD, STL                                       | 79807    | OBD                |
|                  | 210-0046-00        |                  |         | 1   |   |   |   |   |   | WASHER, LOCK: 0.261 ID, INT: 0.018 THK, BRS<br>***** (END ATTACHING PARTS) ***** | 78189    | 1214-05-00-03541 C |
| -24              |                    |                  |         | 1   |   |   |   |   |   | LAMP, LED (SEE CR70 REPL)                                                        |          |                    |
| -25              | 333-1563-00        |                  |         | 1   |   |   |   |   |   | PANEL, FRONT<br>(PS501 ONLY)                                                     | 80009    | 333-1563-00        |
|                  |                    |                  |         | -   |   |   |   |   |   |                                                                                  |          |                    |
| -26              | 333-1564-00        |                  |         | 1   |   |   |   |   |   | PANEL, FRONT<br>(PS501-1 ONLY)                                                   | 80009    | 333-1564-00        |
|                  |                    |                  |         | -   |   |   |   |   |   |                                                                                  |          |                    |
| -27              | 200-0936-00        |                  |         | 1   |   |   |   |   |   | BASE, LAMP: PHOENIX: 0.19 CASE                                                   | 80009    | 200-0936-00        |
| -28              | 378-0602-01        |                  |         | 1   |   |   |   |   |   | LENS, LIGHT: AMBER                                                               | 80009    | 378-0602-01        |
| -29              | 352-0157-00        |                  |         | 1   |   |   |   |   |   | LAMP: PHOENIX: WHITE PLASTIC                                                     | 80009    | 352-0157-00        |

Replaceable Mechanical Parts—PS 501 (-1, -2)

| Fig. & Index No. | Tektronix Part No. | Serial/Model No. |          | Qty | 1 | 2 | 3 | 4 | 5 | Name & Description                                                                                                       | Mfr Code | Mfr Part Number |
|------------------|--------------------|------------------|----------|-----|---|---|---|---|---|--------------------------------------------------------------------------------------------------------------------------|----------|-----------------|
|                  |                    | Eff              | Descrpt  |     |   |   |   |   |   |                                                                                                                          |          |                 |
| -30              | 214-1513-01        | B0101000         | B0521899 | 1   |   |   |   |   |   | LCH. PLUG-IN RETT<br>(PS501-1, PS501-2 ONLY)                                                                             | 80009    | 214-1513-01     |
|                  | 105-0719-00        | B0521840         |          | 1   |   |   |   |   |   | LATCH RETAINING PLUG-IN<br>(PS501-1, PS501-2 ONLY)<br>***** (ATTACHING PARTS) *****<br>***** (END ATTACHING PARTS) ***** | 80009    | 105-0719-00     |
| -31              | 213-0254-00        |                  |          | 1   |   |   |   |   |   | SCREW, TP (CF: 632 X 0.250, 100 DEG, FEH H<br>***** (END ATTACHING PARTS) *****                                          | 45722    | ORB D           |
|                  | 105-0718-00        | B0521840         | B0531099 | 1   |   |   |   |   |   | BAR, LATCH RELEASE<br>(PS501-1 ONLY)                                                                                     | 80009    | 105-0718-00     |
|                  | 105-0718-01        | B0531100         |          | 1   |   |   |   |   |   | BAR, LATCH RELEASE<br>(PS501-1 ONLY)                                                                                     | 80009    | 105-0718-01     |
|                  | 105-0718-00        | B0101000         | B0418999 | 1   |   |   |   |   |   | BAR, LATCH RELEASE<br>(PS501-2 ONLY)                                                                                     | 80009    | 105-0718-00     |
|                  | 105-0718-01        | B0419000         |          | 1   |   |   |   |   |   | BAR, LATCH RELEASE<br>(PS501-2 ONLY)                                                                                     | 80009    | 105-0718-01     |
| -32              | 426-0941-00        |                  |          | 1   |   |   |   |   |   | FRAME INDICATOR<br>(PS501-1 ONLY)                                                                                        | 80009    | 426-0941-00     |
| -33              | 401-0189-00        |                  |          | 1   |   |   |   |   |   | GEAR, SECTOR TO TEETH, PLASTIC<br>(PS501-1 ONLY)                                                                         | 80009    | 401-0189-00     |
| -34              | 401-0190-00        |                  |          | 1   |   |   |   |   |   | GEAR, SECTOR TO TEETH, PLASTIC<br>(PS501-1 ONLY)                                                                         | 80009    | 401-0190-00     |
|                  | 376-0051-00        |                  |          | 1   |   |   |   |   |   | CPLG SHAFT, FLX: 0.127 ID X 0.375 ID DELRINN<br>(PS501-1 ONLY)                                                           | 80009    | 376-0051-00     |
|                  | 384-1171-00        |                  |          | 1   |   |   |   |   |   | EXTENSION SHAFT: 1.05 LX 0.125 O.D. AL<br>(PS501-1 ONLY)                                                                 | 80009    | 384-1171-00     |
| -35              |                    |                  |          | 1   |   |   |   |   |   | RESISTOR, VARIO (SEE R42 REPL)<br>(PS501-1 ONLY)<br>***** (ATTACHING PARTS) *****                                        |          |                 |
| -36              | 210-0807-00        |                  |          | 1   |   |   |   |   |   | WASHER, FLAT: 0.312 ID X 0.05 THK, STSL<br>***** (END ATTACHING PARTS) *****                                             | 12327    | ORB D           |
| -37              | 352-0338-00        | B0101000         | B0539299 | 1   |   |   |   |   |   | HOLDER, DIAL<br>(PS501-1 ONLY)                                                                                           | 80009    | 352-0338-00     |
|                  | 352-0338-02        | B0539300         |          | 1   |   |   |   |   |   | HOLDER, DIAL<br>(PS501-1 ONLY)<br>***** (ATTACHING PARTS) *****                                                          | 80009    | 352-0338-02     |
| -38              | 211-0101-00        |                  |          | 2   |   |   |   |   |   | SCREEN, MACHINE: 4-ME X 0.25, 100 DEG, FEH, STSL                                                                         | 83385    | ORB D           |
|                  | 210-0870-00        |                  |          | 2   |   |   |   |   |   | WASHER, FLAT: 0.174 ID X 0.312 INCH OD, STSL                                                                             | 12327    | ORB D           |
|                  | 210-0586-00        | B0539300         |          | 2   |   |   |   |   |   | NUT, PLASTIC: 8MM-40 X 0.25, STSL<br>***** (END ATTACHING PARTS) *****                                                   | 83385    | ORB D           |
| -39              | 331-0310-00        |                  |          | 1   |   |   |   |   |   | DIAL, CONTROL: 00 TURNS, DIGITAL COUNTS<br>(PS501-1 ONLY)                                                                |          |                 |
| -40              | 386-2348-00        |                  |          | 1   |   |   |   |   |   | SUBPANEL, FRONT<br>(PS501-1 ONLY)<br>***** (ATTACHING PARTS) *****                                                       | 80009    | 386-2348-00     |
|                  | 213-0229-00        | B0101000         | B0532999 | 4   |   |   |   |   |   | SCR, TP (THD) RB: 6-20 X 0.375" 100 DEG, FEH, ST                                                                         | 93907    | ORB D           |
|                  | 213-0123-00        | B0533000         |          | 4   |   |   |   |   |   | SCREW, TP (CF: 6-82 X 0.375) S-BOLT TYPE, FEH H<br>(PS501-1 ONLY)                                                        | 93907    | ORB D           |
|                  | 213-0229-00        | B0101000         | B0419999 | 4   |   |   |   |   |   | SCR, TP (THD) RB: 6-20 X 0.375" 100 DEG, FEH, ST<br>(PS501-2 ONLY)                                                       | 93907    | ORB D           |
|                  | 213-0123-00        | B0419990         |          | 4   |   |   |   |   |   | SCREW, TP (CF: 6-82 X 0.375) S-BOLT TYPE, FEH H<br>(PS501-2 ONLY)<br>***** (END ATTACHING PARTS) *****                   | 93907    | ORB D           |
| -41              | 337-1637-00        |                  |          | 1   |   |   |   |   |   | SHLD, ELECTRICAL (REAR) SUBPANEL<br>(PS501-1 ONLY)                                                                       | 80009    | 337-1637-00     |
| -42              | 384-1101-01        | B0101000         | B0580599 | 1   |   |   |   |   |   | SHAFT, GRASSY<br>(PS501-1 ONLY)                                                                                          | 80009    | 384-1101-01     |
|                  | 384-1101-02        | B0580600         |          | 1   |   |   |   |   |   | SHAFT, GRASSY<br>(PS501-1 ONLY)                                                                                          | 80009    | 384-1101-02     |
| -43              | 384-1058-00        |                  |          | 1   |   |   |   |   |   | EXTENSION SHAFT: 8.157 INCH LONG                                                                                         | 80009    | 384-1058-00     |
| -44              | 386-2528-00        |                  |          | 1   |   |   |   |   |   | SUBPANEL, FRONT<br>***** (ATTACHING PARTS) *****                                                                         | 80009    | 386-2528-00     |
| -45              | 213-0229-00        |                  |          | 4   |   |   |   |   |   | SCR, TP (THD) RB: 6-20 X 0.375" 100 DEG, FEH, ST<br>***** (END ATTACHING PARTS) *****                                    | 93907    | ORB D           |

| Fig. & Index No. | Tektronix Part No. | Serial/Model No. |          | Qty | Name & Description                                                                    | Mfr Code | Mfr Part Number |
|------------------|--------------------|------------------|----------|-----|---------------------------------------------------------------------------------------|----------|-----------------|
|                  |                    | Eff              | Discont  |     |                                                                                       |          |                 |
| -46              | 337-1638-00        |                  |          | 1   | SHLD ELEC CTGICAL REARSUBPANEL (PS501 ONLY)                                           | 80009    | 337-1638-00     |
| -47              | -----              |                  |          | 1   | CKT BOARD ASSY MAIN (SEE A1 REPL) (PS501 ONLY)                                        |          |                 |
| -48              | 136-0252-04        | B0101000         | B0504099 | 25  | .SOCKET, PIN TERMIN/W/O 0.016-0.018 DIA PINS                                          | 22528    | 75060-007       |
|                  | 136-0252-04        | B0504100         |          | 9   | .SOCKET, PIN TERMIN/W/O 0.016-0.018 DIA PINS                                          | 22528    | 75060-007       |
|                  | 136-0514-00        | B0504100         | B0559499 | 2   | .SKT, PL-IN ELEC MICROWAVE CIRCUIT, 8, DIP (PS501-1 ONLY)                             | 73808    | CS9002-8        |
|                  | 136-0727-00        | B0559580         |          | 2   | .SKT, PL-IN ELEC MICROWAVE, 8, CONTACT (PS501-1 ONLY)                                 | 09922    | DILB8P-108      |
|                  | 136-0514-00        | B0504100         |          | 2   | .SKT, PL-IN ELEC MICROWAVE CIRCUIT, 8, DIP (PS501-2 ONLY)                             | 73808    | CS9002-8        |
| -49              | -----              |                  |          | 1   | .INTEGRATED CIRCUIT (SEE U2 REPL) ***** (ATTACHING PARTS) *****                       |          |                 |
| -50              | 211-0510-00        | B0101000         | B0199999 | 2   | .SCREW MACHINE #02 X 0.375 PNNI STL CD PL                                             | 83385    | ORBD            |
|                  | 211-0511-00        | B0200000         | B0528499 | 2   | .SCREW MACHINE #02 X 0.500 PNNI STL CD PL                                             | 83385    | ORBD            |
|                  | 211-0578-00        | B0528580         |          | 2   | .SCREW MACHINE #02 X 0.438 INCH PNNI STL                                              | 83385    | ORBD            |
| -51              | 214-1713-00        |                  |          | 1   | .HEAT SINK ELEC TRANSISTOR ***** (END ATTACHING PARTS) *****                          | 80009    | 214-1713-00     |
| -52              | 136-0384-00        |                  |          | 2   | .SOCKET, PIN TERMIN FOR 0.04 DIAMETER PIN                                             | 00779    | 52120           |
| -53              | 136-0361-00        |                  |          | 1   | .SPACER XSBTR                                                                         | 80009    | 136-0361-00     |
| -54              | 131-0847-00        |                  |          | 2   | .TERMINAL STD 06-32 X 0.435 INCH LONG                                                 | 80009    | 131-0847-00     |
| -55              | -----              |                  |          | 1   | .SWITCH PUSH (SEE S10 REPL)                                                           |          |                 |
| -56              | 361-0384-00        | B0101000         | B0199999 | 2   | .SPACER PP SW 0.133 INCH LONG                                                         | 80009    | 361-0384-00     |
|                  | 361-0385-00        | B0200000         |          | 1   | .SPACER PP SW 0.164 INCH LONG                                                         | 80009    | 361-0385-00     |
| -57              | -----              |                  |          | 1   | .CAPACITOR (SEE C10 REPL) ***** (ATTACHING PARTS) *****                               |          |                 |
| -58              | 211-0534-00        |                  |          | 2   | .SCREWS M8HQR 3R X 0.312 INCH PNNI STL                                                | 83385    | ORBD            |
|                  | 210-0407-00        |                  |          | 2   | .NUT, PLAIN M8E 32 X 0.25 INCH BBS                                                    | 73748    | 3038-0228-402   |
| -59              | 352-0322-00        |                  |          | 1   | .RETAINER, RCPA 375 DIA HQRZ MOUNT ***** (END ATTACHING PARTS) *****                  | 80009    | 352-0322-00     |
| -60              | 213-0146-00        |                  |          | 4   | .SCR, TP 0.130 HQR 20 X 0.313 INCH PNNI STL ***** (END ATTACHING PARTS) *****         | 83385    | ORBD            |
| -61              | -----              |                  |          | 1   | CKT BOARD ASSY MAIN (SEE A1 REPL) (PS501-1 ONLY)                                      |          |                 |
| -62              | 136-0252-04        | B0101000         | B0505299 | 25  | .SOCKET, PIN TERMIN/W/O 0.016-0.018 DIA PINS                                          | 22528    | 75060-007       |
|                  | 136-0252-04        | B0505300         |          | 9   | .SOCKET, PIN TERMIN/W/O 0.016-0.018 DIA PINS                                          | 22528    | 75060-007       |
|                  | 136-0514-00        | B0505300         |          | 2   | .SKT, PL-IN ELEC MICROWAVE CIRCUIT, 8, DIP                                            | 73803    | CS9002-8        |
| -63              | -----              |                  |          | 1   | .MICROWAVE CIRCUIT (SEE U2 REPL) ***** (ATTACHING PARTS) *****                        |          |                 |
| -64              | 211-0510-00        | B0101000         | B0199999 | 2   | .SCREW MACHINE #02 X 0.375 PNNI STL CD PL                                             | 83385    | ORBD            |
|                  | 211-0511-00        | B0200000         |          | 2   | .SCREW MACHINE #02 X 0.500 PNNI STL CD PL                                             | 83385    | ORBD            |
| -65              | 214-1713-00        | B0200000         |          | 1   | .HEAT SINK ELEC TRANSISTOR ***** (END ATTACHING PARTS) *****                          | 80009    | 214-1713-00     |
| -66              | 136-0384-00        |                  |          | 2   | .SOCKET, PIN TERMIN FOR 0.04 DIAMETER PIN                                             | 00779    | 52120           |
| -67              | 136-0361-01        | B0101000         | B0547587 | 1   | .SPACER XSBTR 0.133 INCH LONG                                                         | 80009    | 136-0361-00     |
|                  | 136-0361-01        | B0547588         |          | 1   | .SPACER XSBTR 0.164 INCH LONG                                                         | 80009    | 136-0361-01     |
| -68              | 131-0847-00        |                  |          | 2   | .TERMINAL STD 06-32 X 0.435 INCH LONG                                                 | 80009    | 131-0847-00     |
| -69              | -----              |                  |          | 1   | .SWITCH PUSH (SEE S10 REPL)                                                           |          |                 |
| -70              | 361-0384-00        | B0101000         | B0102537 | 2   | .SPACER PP SW 0.133 INCH LONG                                                         | 80009    | 361-0384-00     |
|                  | 361-0385-00        | B0102588         |          | 2   | .SPACER PP SW 0.164 INCH LONG                                                         | 80009    | 361-0385-00     |
| -71              | -----              |                  |          | 1   | .CAPACITOR (SEE C10 REPL) ***** (ATTACHING PARTS) *****                               |          |                 |
| -72              | 211-0534-00        |                  |          | 2   | .SCREWS M8HQR 3R X 0.312 INCH PNNI STL                                                | 83385    | ORBD            |
|                  | 210-0407-00        |                  |          | 2   | .NUT, PLAIN M8E 32 X 0.25 INCH BBS                                                    | 73748    | 3038-0228-402   |
| -73              | 352-0322-00        | B0101000         | B0551999 | 1   | .RETAINER, RCPA 375 DIA HQRZ MOUNT ***** (END ATTACHING PARTS) *****                  | 80009    | 352-0322-00     |
|                  | 352-0322-01        | B0552000         |          | 1   | .RETAINER, RCPA 375 DIA HQRZ MOUNT ***** (PS501-1 ONLY) ***** (ATTACHING PARTS) ***** | 80009    | 352-0322-01     |
| -74              | 213-0146-00        |                  |          | 4   | .SCR, TP 0.130 HQR 20 X 0.313 INCH PNNI STL ***** (END ATTACHING PARTS) *****         | 83385    | ORBD            |
| -75              | 129-0089-00        |                  |          | 2   | .POST ELEC MECH #02 X 0.25 X 0.89 INCH ***** (ATTACHING PARTS) *****                  | 80009    | 129-0089-00     |
| -76              | 211-0504-00        |                  |          | 2   | .SCREW MACHINE #02 X 0.25 INCH PNNI STL ***** (END ATTACHING PARTS) *****             | 83385    | ORBD            |

Replaceable Mechanical Parts—PS 501 (-1, -2)

| Fig. & Index No. | Tektronix Part No. | Serial/Model No. Eff | Discont  | Qty | 1 | 2 | 3 | 4 | 5 | Name & Description                                                                                              | Mfr Code | Mfr Part Number  |
|------------------|--------------------|----------------------|----------|-----|---|---|---|---|---|-----------------------------------------------------------------------------------------------------------------|----------|------------------|
| -77              | ----               | ----                 |          | 1   |   |   |   |   |   | CKT BOARD ASSY SECONDARY (SEE S42 REPL)<br>(PS501-1 ONLY)                                                       |          |                  |
| -78              | ----               | ----                 |          | 1   |   |   |   |   |   | .SWITCH PULBHS (SEE S42 REPL)                                                                                   |          |                  |
| -79              | 361-0383-00        |                      |          | 2   |   |   |   |   |   | .SPACE RPP SWCH CAR COALD, 36 INCH LONG<br>..... (ATTACHING PARTS FRONT BD)<br>..... (END ATTACHING PARTS)..... | 80009    | 361-0383-000     |
| -80              | 211-0504-000       |                      |          | 2   |   |   |   |   |   | SCREEN MACHINER: 6.92 X 0.25 INCH PINH STILL<br>..... (END ATTACHING PARTS).....                                | 83385    | ORB D            |
|                  | 386-3657-00        | B0521660             | B0534699 | 2   |   |   |   |   |   | SUPPORT PLUG IN<br>(PS501-1 ONLY)                                                                               | 80009    | 386-3657-000     |
|                  | 386-3657-01        | B0534990             |          | 2   |   |   |   |   |   | SUPPORT PLUG LING<br>(PS501-1 ONLY)                                                                             | 93907    | ORB D            |
|                  | 210-1270-00        | B0521660             |          | 2   |   |   |   |   |   | WASHER FLAT: 0.141 ID X 0.04 THK, AAL<br>(PS501-1 ONLY)                                                         | 80009    | 210-1270-000     |
|                  | 386-3657-00        | B0411480             | B0420699 | 2   |   |   |   |   |   | SUPPORT PLUG IN<br>(PS501-2 ONLY)                                                                               | 80009    | 386-3657-000     |
|                  | 386-3657-01        | B0420700             |          | 2   |   |   |   |   |   | SUPPORT PLUG LING<br>(PS501-2 ONLY)                                                                             | 93907    | ORB D            |
|                  | 210-1270-000       | B0411480             |          | 2   |   |   |   |   |   | WASHER FLAT: 0.141 ID X 0.04 THK, AAL<br>(PS501-2 ONLY)                                                         | 80009    | 210-1270-000     |
| -81              | 426-0724-000       |                      |          | 1   |   |   |   |   |   | FR SECT, RULGIN: BOTTOM                                                                                         | 80009    | 426-0724-00      |
| -82              | 426-0725-000       |                      |          | 1   |   |   |   |   |   | FR SECT, RULGIN: TOP                                                                                            | 80009    | 426-0725-00      |
| -83              | 179-1833-00        |                      |          | 1   |   |   |   |   |   | WIRING HARNESS, MAIN<br>(PS501 ONLY)                                                                            | 80009    | 179-1833-000     |
| -84              | 366-1319-00        |                      |          | 1   |   |   |   |   |   | KNOB BRAY<br>(PS501-2 ONLY)                                                                                     | 80009    | 366-1319-000     |
|                  | 213-0140-00        |                      |          | 1   |   |   |   |   |   | .SET SCREW: 2.66 X 0.94 INCH, HEX, SOCS T                                                                       | 70276    | ORB D            |
| -85              | 366-1077-00        |                      |          | 1   |   |   |   |   |   | KNOB BRAY<br>(PS501-2 ONLY)                                                                                     | 80009    | 366-1077-000     |
|                  | 213-0020-000       |                      |          | 1   |   |   |   |   |   | .SET SCREW: 6.02 X 0.125 INCH, HEX, SOCS                                                                        | 70276    | ORB D            |
| -86              | 366-0494-000       |                      |          | 1   |   |   |   |   |   | KNOB BRAY WITH SET SCREW                                                                                        | 80009    | 366-0494-000     |
|                  | 213-0153-000       |                      |          | 1   |   |   |   |   |   | .SET SCREW: 5.0 X 0.125, STL BK OXO, HEX X                                                                      | 0000Y    | ORB D            |
| -87              | 366-1257-744       |                      |          | 1   |   |   |   |   |   | PUSH BUTTON ON BRAY ON N                                                                                        | 80009    | 366-1257-744     |
| -88              | 366-1489-033       |                      |          | 1   |   |   |   |   |   | PUSH BUTTON ON L GY, AMP P<br>(PS501-2 ONLY)                                                                    | 80009    | 366-1489-033     |
| -89              | 426-0681-000       |                      |          | 2   |   |   |   |   |   | FR PUSH BUTTON ON BRAY PLASTIC                                                                                  | 80009    | 426-0681-000     |
| -90              | 129-0064-01        |                      |          | 2   |   |   |   |   |   | POST, BDD, GLE, EC, RED, 5-WAY MINIATURE<br>..... (ATTACHING PARTS).....                                        | 58474    | A207799; G22     |
| -92              | 358-0181-000       |                      |          | 4   |   |   |   |   |   | INSULATOR BS HS CAR COALD<br>..... (END ATTACHING PARTS).....                                                   | 58474    | B207516-G7/INSUL |
| -93              | 129-0064-00        |                      |          | 1   |   |   |   |   |   | POST, BDD, GLE, EC, CAR COALD, 5-WAY MINIATURE<br>..... (ATTACHING PARTS).....                                  | 58474    | A207799; G7      |
| -94              | 210-0457-000       |                      |          | 1   |   |   |   |   |   | NUT, PLASSEMB: 4-32 X 0.312, STL CDPL                                                                           | 83385    | ORB D            |
| -95              | 358-0181-000       |                      |          | 1   |   |   |   |   |   | INSULATOR BS HS CAR COALD<br>..... (END ATTACHING PARTS).....                                                   | 58474    | B207516-G7/INSUL |
| -96              | 129-0064-02        |                      |          | 1   |   |   |   |   |   | POST, BDD, GLE, EC, WHITE, 5-WAY MINIATURE<br>..... (ATTACHING PARTS).....                                      | 58474    | 207784; G5       |
| -97              | 210-0457-00        |                      |          | 1   |   |   |   |   |   | NUT, PLASSEMB: 4-32 X 0.312, STL CDPL<br>..... (END ATTACHING PARTS).....                                       | 83385    | ORB D            |
| -98              | -----              |                      |          | 1   |   |   |   |   |   | RESISTOR VAR (SEE R06 REPL)<br>..... (ATTACHING PARTS).....                                                     |          |                  |
| -99              | 210-0583-00        |                      |          | 1   |   |   |   |   |   | NUT, PLAIN, HEX: 0.25-32 X 0.312 INCH, BBS                                                                      | 73743    | 2X203073402; O2  |
| -100             | 210-0940-000       |                      |          | 1   |   |   |   |   |   | WASHER FLAT: 0.25 ID X 0.375 INCH OD, STL                                                                       | 79807    | ORB D            |
|                  | 210-0046-000       |                      |          | 1   |   |   |   |   |   | WASHER LOCK: 0.281 ID, INTL, 0.018 THK, BBS<br>..... (END ATTACHING PARTS).....                                 | 78189    | 1214-05-00-0541C |
| -101             | -----              |                      |          | 1   |   |   |   |   |   | RESISTOR VAR (SEE R42, R42 REPL)<br>(PS501-1, PS501-2 ONLY)<br>..... (ATTACHING PARTS).....                     |          |                  |
| -102             | 210-0583-000       |                      |          | 1   |   |   |   |   |   | NUT, PLAIN, HEX: 0.25-32 X 0.312 INCH, BBS                                                                      | 73743    | 2X20317-4002     |
| -103             | 210-0940-000       |                      |          | 1   |   |   |   |   |   | WASHER FLAT: 0.25 ID X 0.375 INCH OD, STL                                                                       | 79807    | ORB D            |
|                  | 210-0046-000       |                      |          | 1   |   |   |   |   |   | WASHER LOCK: 0.281 ID, INTL, 0.018 THK, BBS<br>..... (END ATTACHING PARTS).....                                 | 78189    | 1214-05-00-0541C |
| -104             | 333-1714-000       |                      |          | 1   |   |   |   |   |   | PANEL FRONT<br>(PS501-2 ONLY)                                                                                   | 80009    | 333-1714-000     |
| -105             | 200-0935-000       |                      |          | 1   |   |   |   |   |   | BASE LAMP HOLDER: 0.29 OD X 0.19 CASE                                                                           | 80009    | 200-0935-000     |
| -106             | 378-0602-01        |                      |          | 1   |   |   |   |   |   | LENS, LIGHT: PAMBER                                                                                             | 80009    | 378-0602-01      |



Replaceable Mechanical Parts—PS 501 (-1, -2)

| Fig. & Index No. | Tektronix Part No. | Serial/Model No. Eff | Discont  | Qty | 1 | 2 | 3 | 4 | 5 | Name & Description                                               | Nfir Code | Nfir Part Number |
|------------------|--------------------|----------------------|----------|-----|---|---|---|---|---|------------------------------------------------------------------|-----------|------------------|
| -107             | 352-0157-00        |                      |          | 1   |   |   |   |   |   | LAMPHOLDER WHITE PLASTIC                                         | 800099    | 352-0157-00      |
| -108             | 149-0036-00        |                      |          | 1   |   |   |   |   |   | NUMBERS 0 MA, 77 OHM, +/-10% O%<br>(PS501-2 ONLY)                | 330055    | MODEL KIT        |
|                  |                    |                      |          | -   |   |   |   |   |   | ***** (ATTACHING PARTS) *****                                    |           |                  |
| -109             | 211-0101-00        |                      |          | 2   |   |   |   |   |   | SCREW MACHINE #4 HEX 0.25, 100 DEG, FENI STILL<br>(PS501-2 ONLY) | 833885    | ORBD             |
| -110             | 210-0406-00        |                      |          | 2   |   |   |   |   |   | NUT, FLAIN, HEX #40 X 0.188 INCH BBS<br>(PS501-2 ONLY)           | 737483    | 12161-50         |
| -111             | 211-0097-00        |                      |          | 2   |   |   |   |   |   | SCREW MACHINE #4 HEX 0.312 INCH PNNI STILL<br>(PS501-2 ONLY)     | 833885    | ORBD             |
| -112             | 210-0201-00        |                      |          | 1   |   |   |   |   |   | TERMINAL LUG #2 IDL, LOCKING BRZ IN PL<br>(PS501-2 ONLY)         | 86928     | ORBD             |
| -113             | 210-0906-00        |                      |          | 2   |   |   |   |   |   | WASHER, NON METAL FIBER, 0.125 ID X 0.203 ODD<br>(PS501-2 ONLY)  | 86928     | ORBD             |
| -114             | 386-2527-00        |                      |          | 1   |   |   |   |   |   | SUPP ORT METEETER<br>(PS501-2 ONLY)                              | 800099    | 386-2527-00      |
| -115             | 210-0849-00        |                      |          | 2   |   |   |   |   |   | WSHR, SHG WLDERED, IRID X 0.188 ODD FIBER<br>(PS501-2 ONLY)      | 833300    | 2151             |
|                  |                    |                      |          | -   |   |   |   |   |   | ***** (END ATTACHING PARTS) *****                                |           |                  |
| -116             | 386-2528-00        |                      |          | 1   |   |   |   |   |   | SUBSTRATE FRONT<br>(PS501-2 ONLY)                                | 800099    | 386-2528-00      |
| -117             | 337-1783-00        |                      |          | 1   |   |   |   |   |   | SHIELD, UEC BEARS SUBPARALLEL<br>(PS501-2 ONLY)                  | 800099    | 337-1783-00      |
| -118             | 384-1058-00        |                      |          | 1   |   |   |   |   |   | EXTENSION SHAFT: 8.157 INCH LONG<br>(PS501-2 ONLY)               | 800099    | 384-1058-00      |
| -119             | 384-1101-00        |                      |          | 1   |   |   |   |   |   | EXTENSION SHAFT: 4.14 INCH LONG<br>(PS501-2 ONLY)                | 800099    | 384-1101-00      |
| -120             |                    |                      |          | 1   |   |   |   |   |   | CKT BOARD ASSY MAIN (SEE A1 REPL)<br>(PS501-2 ONLY)              |           |                  |
| -121             |                    |                      |          | 1   |   |   |   |   |   | MICRO CIRCUIT (SEE U2 REPL)<br>(PS501-2 ONLY)                    |           |                  |
|                  |                    |                      |          | -   |   |   |   |   |   | ***** (ATTACHING PARTS) *****                                    |           |                  |
| -122             | 211-0510-00        |                      |          | 2   |   |   |   |   |   | SCREW MACHINE #2 X 0.375 PNNI STILL, DIP                         | 833885    | ORBD             |
| -123             | 214-1713-00        |                      |          | 1   |   |   |   |   |   | HEAT SINK ELECTRA RESISTOR<br>(PS501-2 ONLY)                     | 800099    | 214-1713-00      |
|                  |                    |                      |          | -   |   |   |   |   |   | ***** (END ATTACHING PARTS) *****                                |           |                  |
| -124             | 136-0386-00        |                      |          | 2   |   |   |   |   |   | SOCKET, PIN TERMINATOR #4 DIA METEER IN                          | 007799    | 52120            |
| -125             | 136-0361-00        | 80101000             | B0428799 | 1   |   |   |   |   |   | SPACER, XSBTR                                                    | 800099    | 136-0361-00      |
|                  | 136-0361-01        | 80425600             |          | 1   |   |   |   |   |   | SPACER, XSBTR-3 ORTO-66                                          | 800099    | 136-0361-01      |
| -126             | 131-0847-00        |                      |          | 2   |   |   |   |   |   | TERMINAL STUD #32 X 0.435 INCH LONG                              | 800099    | 131-0847-00      |
| -127             | 352-0322-00        |                      |          | 1   |   |   |   |   |   | RETAINER, CAP #375 DIA, HORIZ MOUNT<br>(PS501-2 ONLY)            | 800099    | 352-0322-00      |
|                  |                    |                      |          | -   |   |   |   |   |   | ***** (ATTACHING PARTS) *****                                    |           |                  |
| -128             | 211-0534-00        |                      |          | 2   |   |   |   |   |   | SCREW MACHINE #4 HEX 0.312 INCH PNNI STILL                       | 833885    | ORBD             |
| -129             | 210-0407-00        |                      |          | 2   |   |   |   |   |   | NUT, FLAIN, HEX #6-32 X 0.25 INCH BBS<br>(PS501-2 ONLY)          | 737483    | 3038-0228-402    |
|                  |                    |                      |          | -   |   |   |   |   |   | ***** (END ATTACHING PARTS) *****                                |           |                  |
| -130             |                    |                      |          | 1   |   |   |   |   |   | SWITCH, PUSH (SEE S10 REPL)                                      |           |                  |
| -131             |                    |                      |          | 1   |   |   |   |   |   | SWITCH, PUSH (SEE S55 REPL)                                      |           |                  |
| -132             | 361-0386-00        |                      |          | 4   |   |   |   |   |   | SPACER, PPSV#0.133 INCH LONG                                     | 800099    | 361-0386-00      |
| -133             | 136-0252-04        | 80101000             | B0403499 | 25  |   |   |   |   |   | SOCKET, PIN TERMINATOR #0.016-0.018 DIA PINS                     | 22526     | 75060-0077       |
|                  | 136-0252-04        | 8040850              |          | 9   |   |   |   |   |   | SOCKET, PIN TERMINATOR #0.016-0.018 DIA PINS                     | 22526     | 75060-0077       |
|                  | 136-0514-00        | 80403560             |          | 2   |   |   |   |   |   | SKT, PL-IN ELECT MICRO CIRCUIT, 8, DIP                           | 73803     | CS9002-88        |
|                  | 179-1879-00        |                      |          | 1   |   |   |   |   |   | WIRING HARNESS,<br>(PS501-1 ONLY)                                | 800099    | 179-1879-00      |
|                  |                    |                      |          | -   |   |   |   |   |   | ***** (ATTACHING PARTS FOR CKT BD) *****                         |           |                  |
| -134             | 213-0146-00        |                      |          | 4   |   |   |   |   |   | SCREW MACHINE #2 X 0.312 INCH PNNI STILL<br>(PS501-2 ONLY)       | 833885    | ORBD             |
|                  |                    |                      |          | -   |   |   |   |   |   | ***** (END ATTACHING PARTS) *****                                |           |                  |
| -135             | 214-1061-00        | 80101055             |          | 1   |   |   |   |   |   | SPRING, CIRCUIT BOARD<br>(PS501-2 ONLY)                          | 800099    | 214-1061-00      |
|                  |                    |                      |          | -   |   |   |   |   |   |                                                                  |           |                  |

PS 501-2

A1 MAIN

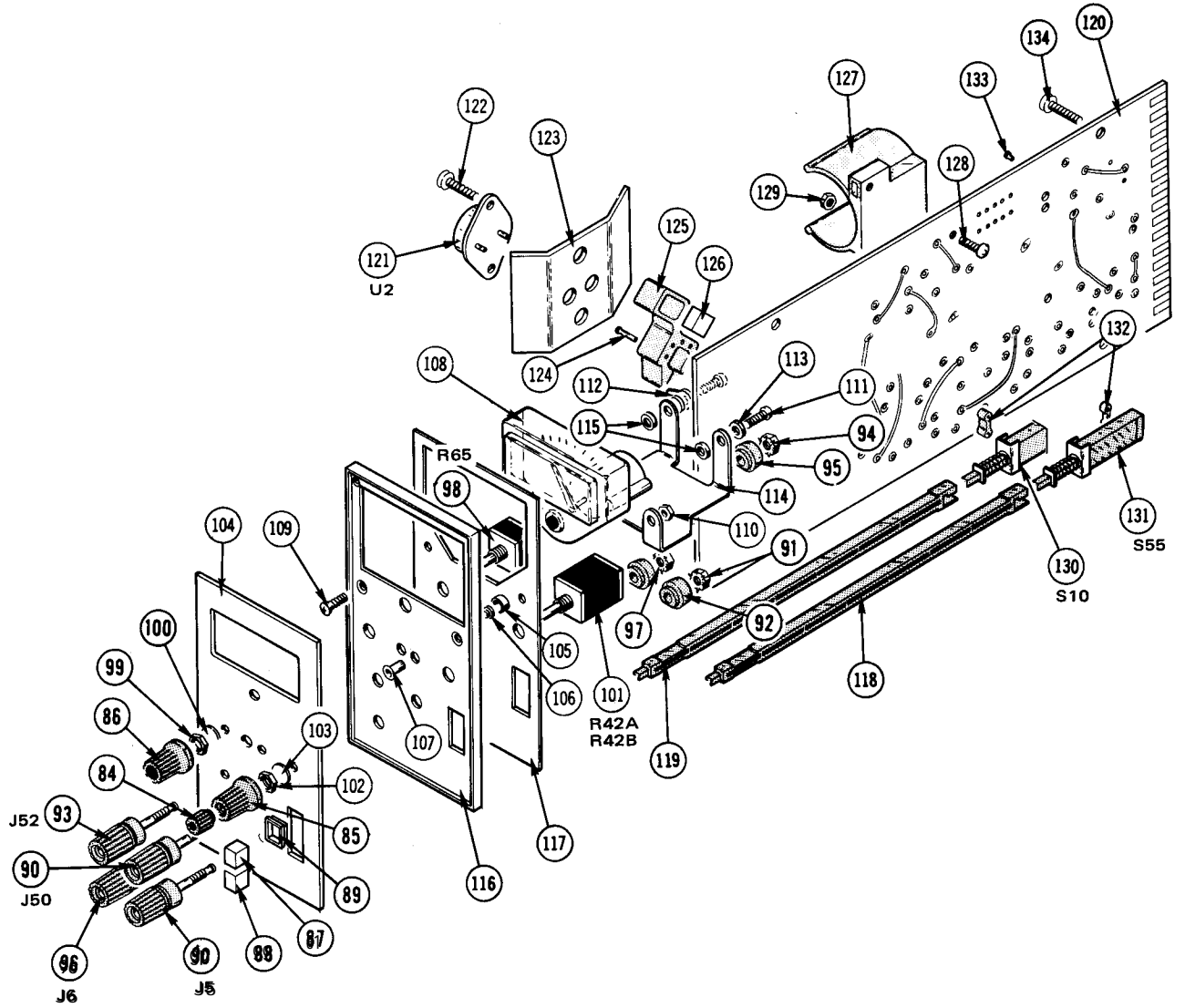

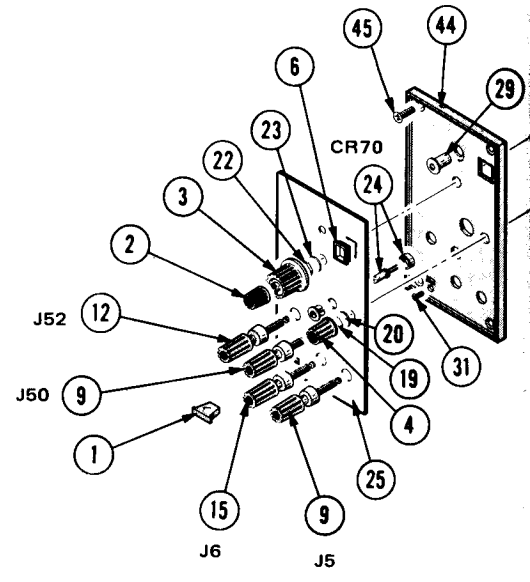
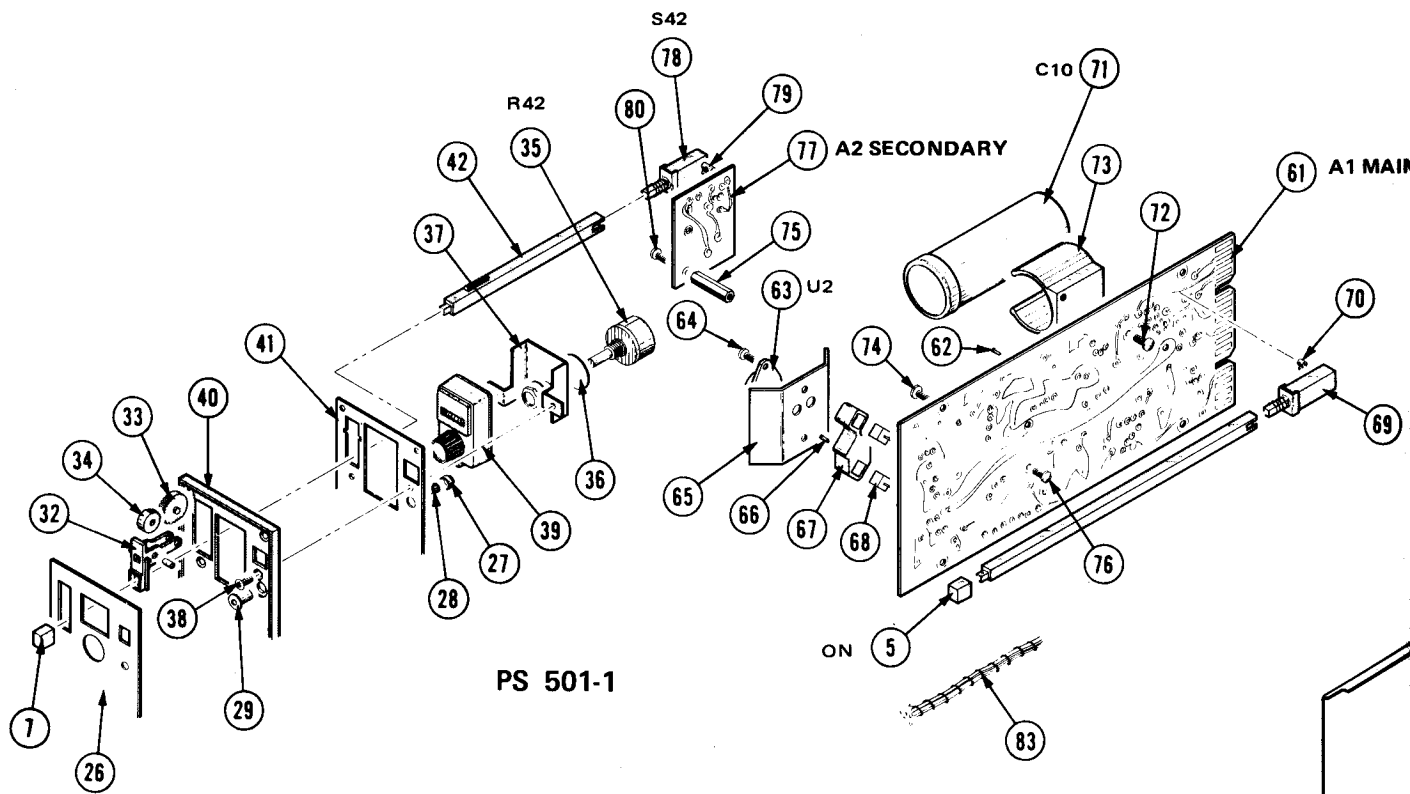

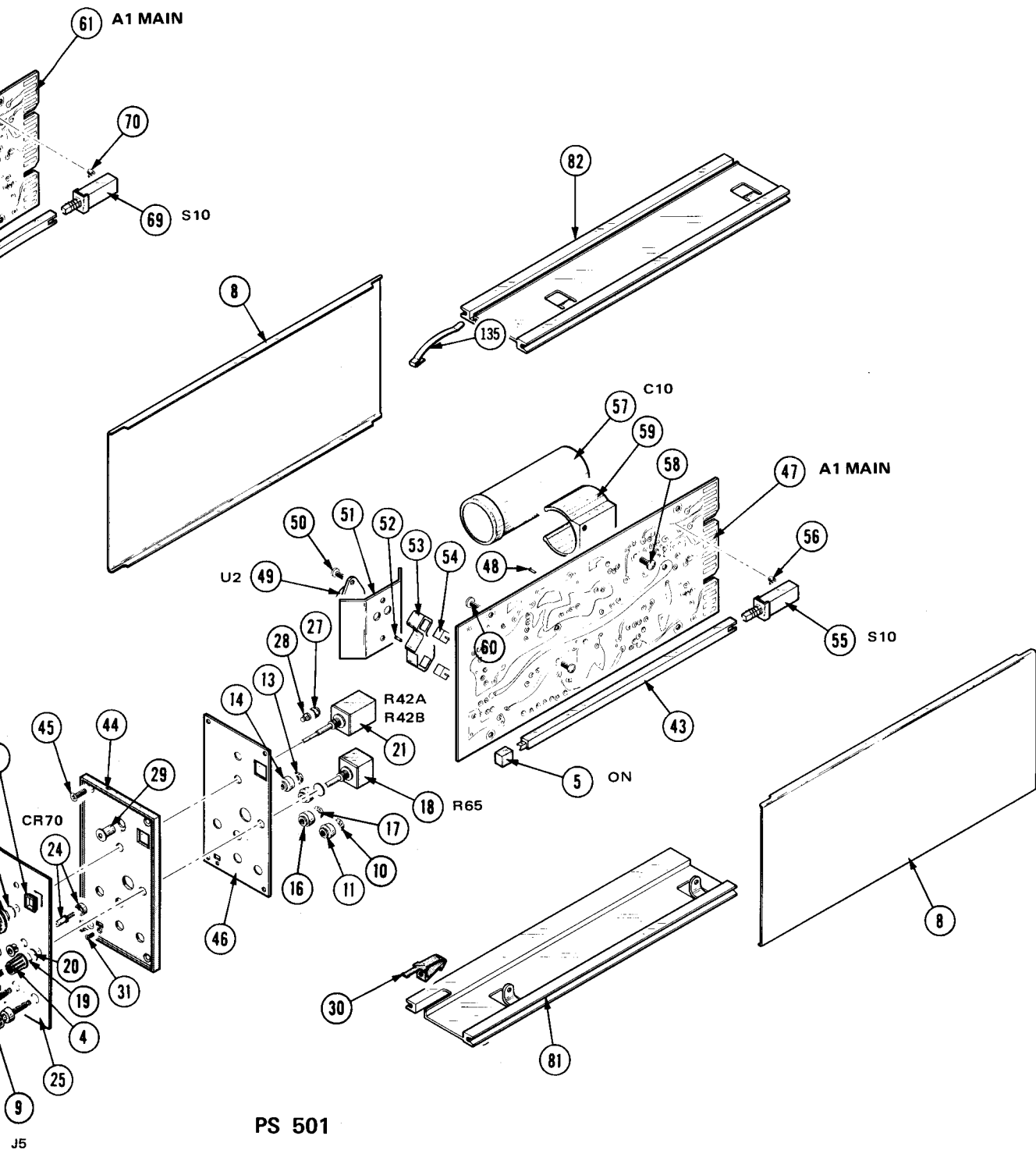

PS 501

| Fig. & Index No. | Tektronix Part No. | Serial Eff | Model No. Discont | Qty | 1 | 2 | 3 | 4 | 5 | Name & Description | Mfr Code | Mfr Part Number |
|------------------|--------------------|------------|-------------------|-----|---|---|---|---|---|--------------------|----------|-----------------|
|------------------|--------------------|------------|-------------------|-----|---|---|---|---|---|--------------------|----------|-----------------|

ACCESSORIES

|               |  |  |  |   |  |  |  |  |  |                               |        |               |
|---------------|--|--|--|---|--|--|--|--|--|-------------------------------|--------|---------------|
| 070-1306-0202 |  |  |  | 1 |  |  |  |  |  | MANUAL, TECHNICAL INSTRUCTION | 800099 | 070-1306-0202 |
|---------------|--|--|--|---|--|--|--|--|--|-------------------------------|--------|---------------|

ACCESSORIES

## **MANUAL CHANGE INFORMATION**

At Tektronix, we continually strive to keep up with latest electronic developments by adding circuit and component improvements to our instruments as soon as they are developed and tested.

Sometimes, due to printing and shipping requirements, we can't get these changes immediately into printed manuals. Hence, your manual may contain new change information on following pages.

A single change may affect several sections. Since the change information sheets are carried in the manual until all changes are permanently entered, some duplication may occur. If no such change pages appear following this page, your manual is correct as printed.

## DESCRIPTION

EFF SN: B056210

**REASON FOR CHANGE** To improve turn-on characteristics of the +20V and -5V supplies and to keep the extreme overload capabilities below the maximum current ratings of the main frame.

### REPLACEMENT ELECTRICAL PARTS LIST CHANGES

#### CHANGE

|      |      |                |                                            |
|------|------|----------------|--------------------------------------------|
| A11  | FROM | 670-2216-6202  | CKT BOARD ASSY: MAIN                       |
|      | TO:  | 670-2216-6303  | CKT BOARD ASSY: MAIN                       |
| R65  | FROM | 3111-13869000  | RES, VAR, 1000 OHM, 1% PINL, 11W           |
|      | TO:  | 3111-10950000  | RES, VAR, 1000 OHM, 1% PINL, 100 OHM, 0.5W |
| ADD: |      |                |                                            |
| R66  |      | 3211-001930707 | RES, FIX, 1K OHM, 0.1%, 0.125W             |

### DIAGRAM CHANGES

#### DIAGRAM POWER SUPPLY

CHANGE R65 (location J6) to a 10K $\Omega$  variable resistor

ADD: R66 (1K $\Omega$ ) from the collector of Q60 to the cathode of CR55.

At location B6, part of S10 is shown as being shorted for PS 501-2 ONLY. This now also applies to PS 501-1 for the serial numbers noted above.