



PS8271 HDMI™/DVI Multiplexer with Level Shifter

Product Brief

PS8271

TYPICAL SYSTEM APPLICATION

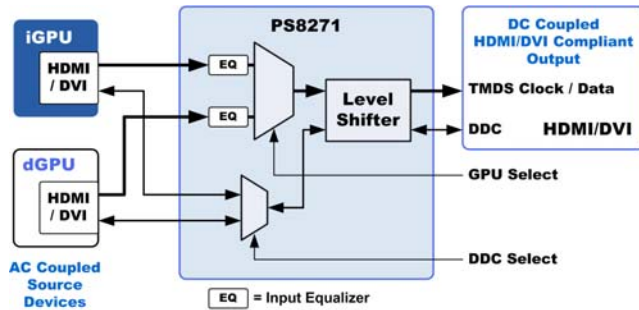

BLOCK DIAGRAM

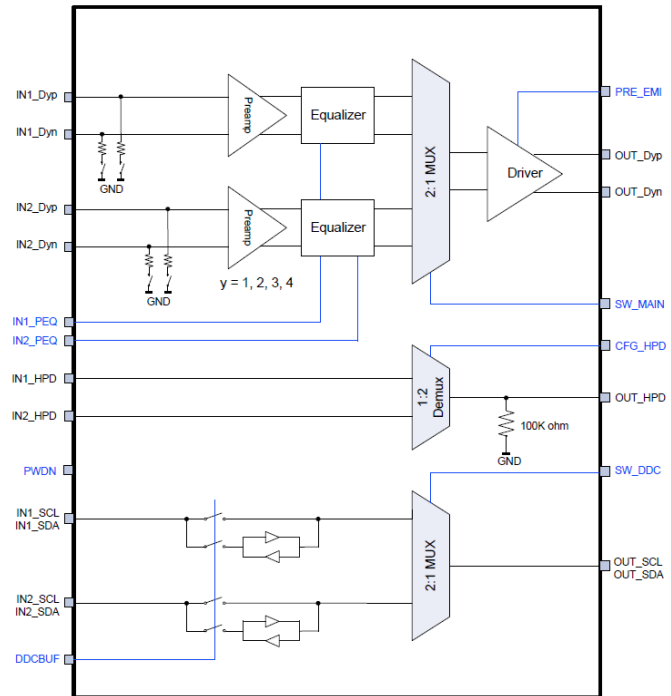

FEATURES

- Provides 2:1 multiplexing for HDMI/DVI signals
- Supports AC coupled HDMI/DVI inputs typical in a PC graphics application
- Output is DC coupled and compliant with HDMI/DVI specifications
- Compliant to HDMI 1.3a specification up to 2.25 Gbps
- Programmable receiver equalization to compensate for PCB and/or connector losses
- Low Intra-pair and Inter-pair skews
- Supports both DDC active buffering and passive switch for Side-band signals
- Automatic Power Down management
- Automatic squelch for fail-safe and power management
- Programmable TMDs output pre-emphasis and EMI reduction
- Separated main data and DDC switching controls for optimized Switchable Graphics
- Single 3.3 V Power Supply
- 0°C to 85°C Operating Temperature Range
- ESD: HBM at 8kV, MM 400V, CDM 2kV
- 48-pin QFN Halogen free RoHS Package

APPLICATIONS

- Switchable graphics in Desktop and Notebook PC motherboards
- Notebook docking stations
- Graphics cards

DESCRIPTION

The PS8271 is a 2:1 HDMI/DVI multiplexer to be used with AC coupled TMDs Source devices. It is suitable for switchable GPU system implementations or other applications requiring multiple HDMI/DVI inputs and a single output. Output is DC coupled and compliant with HDMI/DVI specifications.

The DDC I2C pins are bi-directional and 5V tolerant. HPD pins are uni-directional, and OUT_HPD is 5 V tolerant. The built-in equalization can compensate for the PCB losses up to 7dB.

Information furnished by Parade Technologies is believed to be accurate and reliable. However, no responsibility is assumed by Parade Technologies for its use, nor for any infringements of patents or other rights of third parties that may result from its use. Specification is subject to change without notice. No license is granted by implication or otherwise under any patent or patent rights of Parade Technologies. Trademarks and registered trademarks are the property of their respective owners.

Parade Technologies, Inc.
2890 Zanker Road, Suite 102
San Jose, CA 95134 USA
Tel: 408-329-5540 FAX: 408-329-5541

<http://www.paradetech.com>