Programmable Rolling Code Encoder IC

PT2283

DESCRIPTION

PT2283 is a programmable rolling code encoder IC utilizing CMOS Technology specially designed for remote control applications. It supports up to 20 or 24 bits of programmable address codes, 8 or 4 data bits and 16 bits programmable rolling code. A total of 65,536 rolling code combinations as well as power saving feature and low battery warn mode(except PT2283L) are also provided.

PT2283 encodes the programmed codes into a coded waveform suitable for RF modulation. Pin assignments and application circuit are optimized for easy PCB Layout and cost saving advantage. Housed in either 8 pins or 16 pins DIP or SOP package.

FEATURES

- CMOS Technology
- Low Power Consumption
- Least External Components
- High Noise Immunity
- Operating Voltage: 4V to 10V
- Up to 20 or 24 Address Codes
- Up to 8 or 4 Data Bits
- Up to 2⁴³ Output Code Combinations
- Power Saving Feature
- Low Battery Warn Mode (except PT2283L)
- Available in 8 or 16 pins, SOP or DIP Package

APPLICATIONS

- Burglar Alarm System
- Car Security System
- Car/Garage Door Controller
- Home/Office Security System
- Personal Alarm System

Programmable Rolling Code Encoder IC

PT2283

BLOCK DIAGRAM

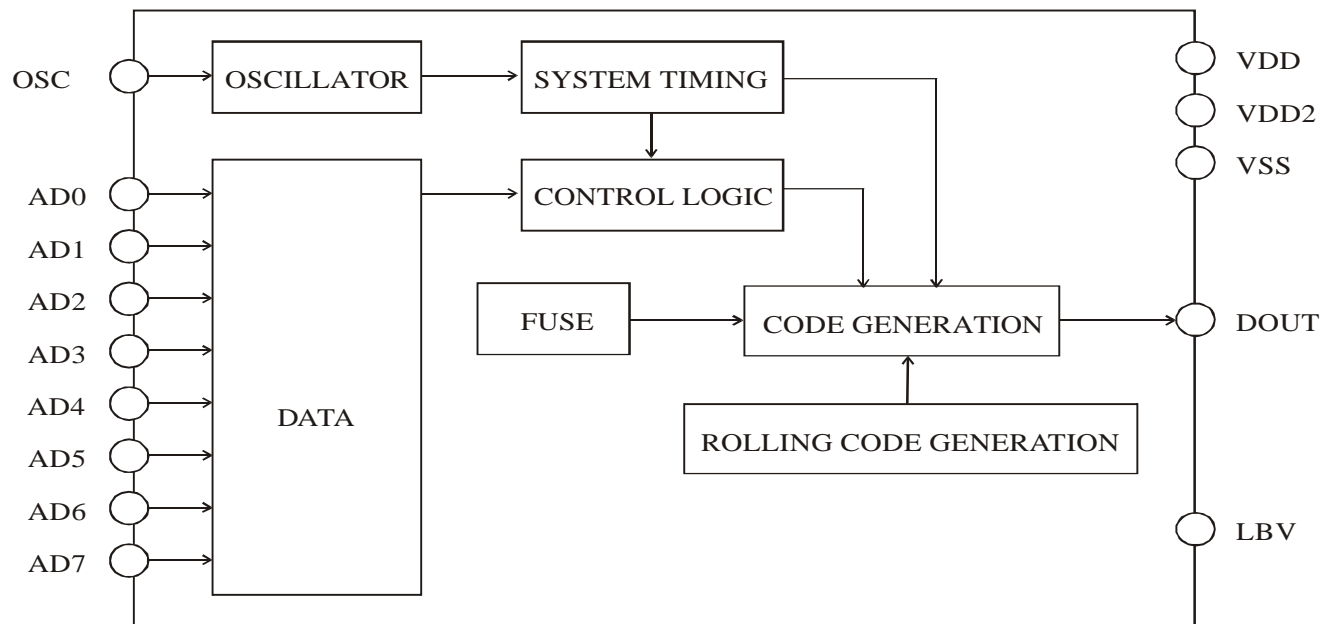

PIN CONFIGURATION

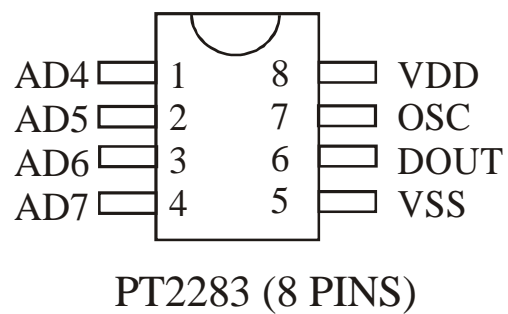
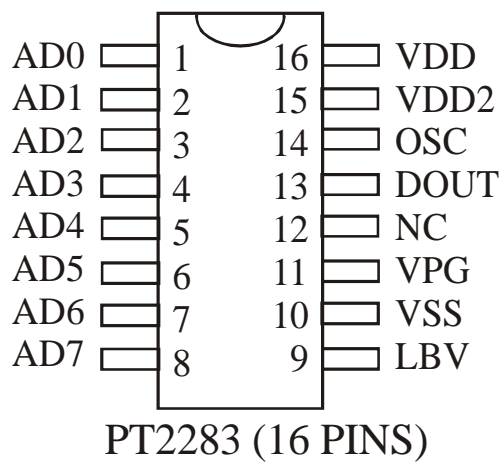

APPLICATION CIRCUIT 1

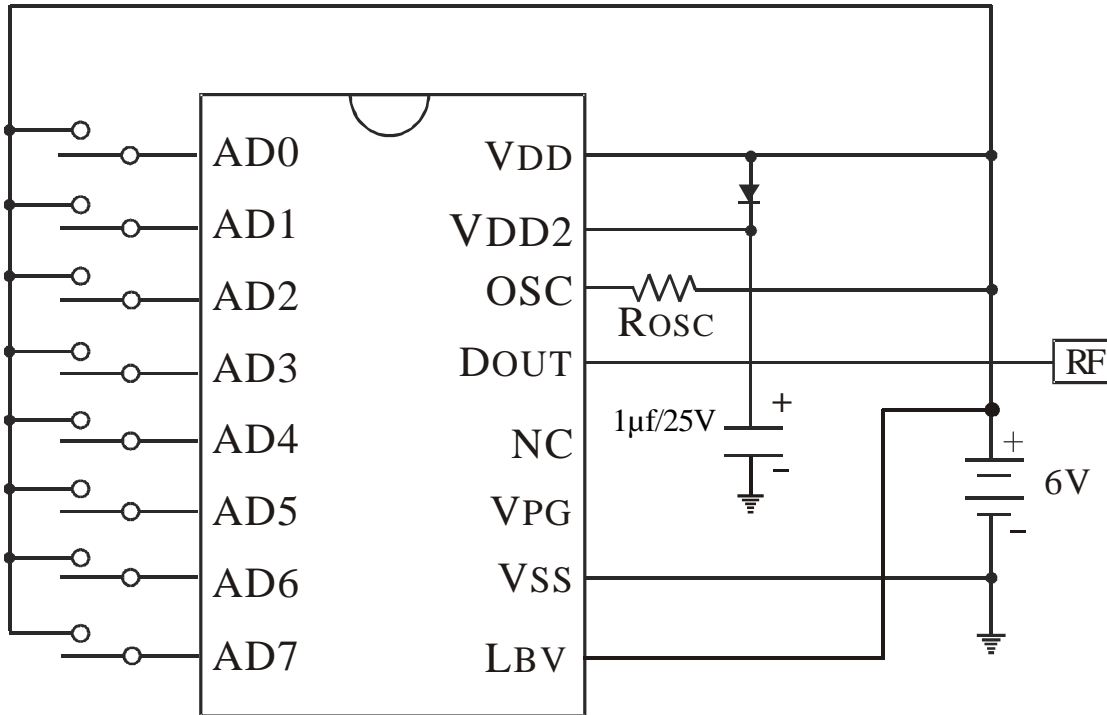

PT2283 (16 Pin)

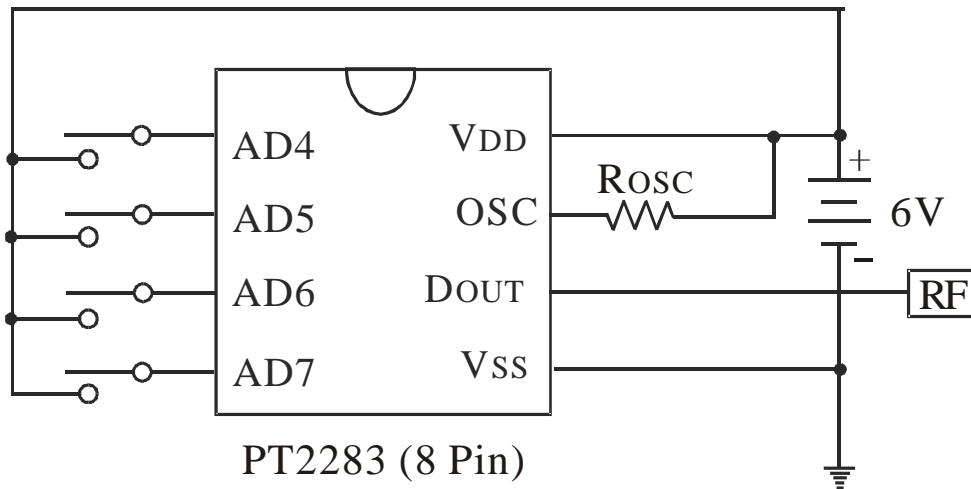

PT2283 (8 Pin)

Programmable Rolling Code Encoder IC

PT2283

APPLICATION CIRCUIT 2

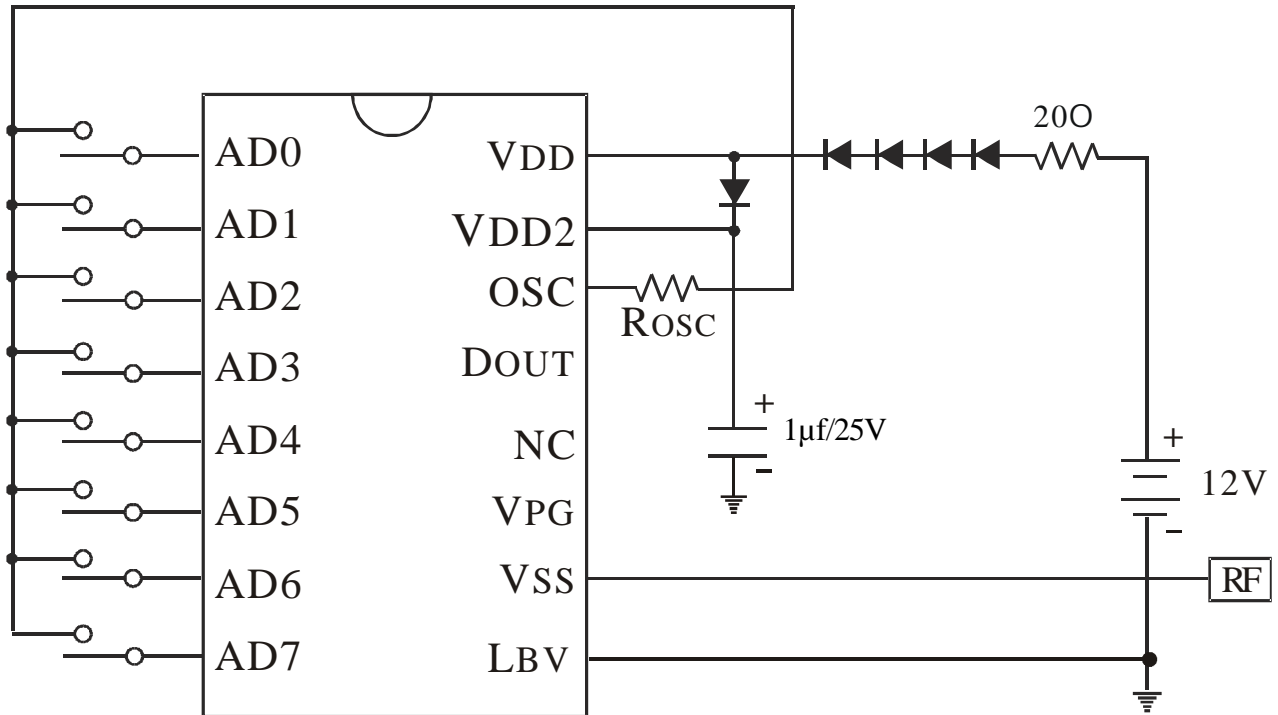

PT2283 (16 Pin)

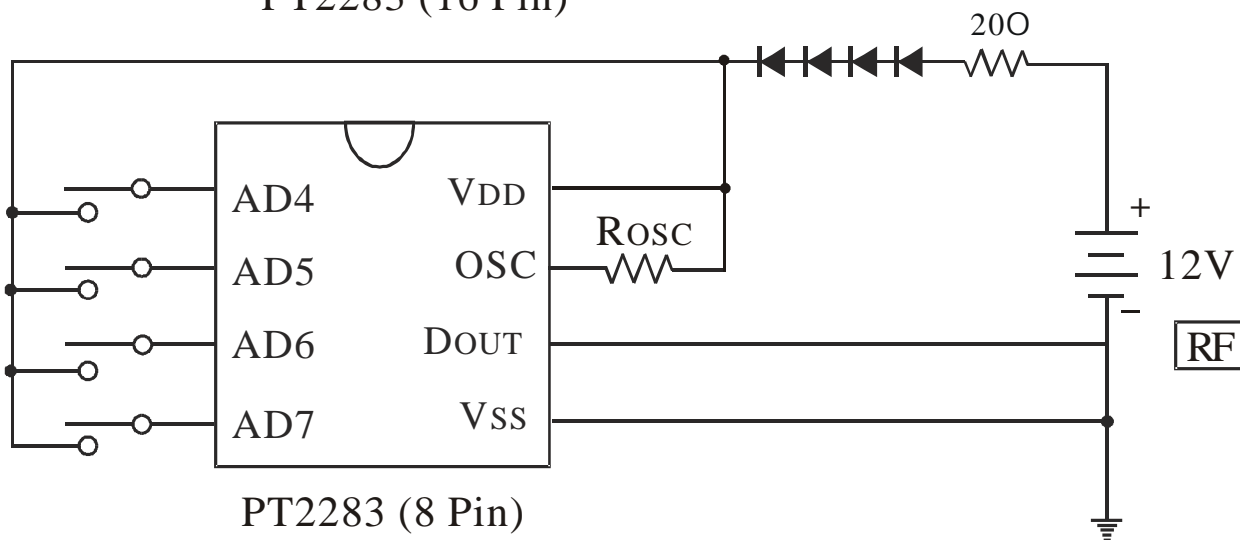

PT2283 (8 Pin)

Programmable Rolling Code Encoder IC**PT2283**

ORDER INFORMATION

Order Part Number	Package Type	Top Code
PT2283	8 Pins, DIP (300 mil) , Programmable	PT2283
PT2283L	8 Pins, DIP (300 mil), Programmable, No Battery Warm Mode	PT2283L
PT2283-S	8 Pins, SOP (150 mil), Programmable	PT2283-S
PT2283L-S	8 Pins, SOP (150 mil), Programmable, No. Battery Warm Mode	PT2283L-S
PT2283-16	16 Pins, DIP (300 mil), Programmable	PT2283-16
PT2283-16S	16 Pins, SOP (150 mil), Programmable	PT2283-16S
PT2283P	8 Pins, DIP (300 mil), Programmed	PT2283P
PT2283LP	8 Pins, DIP (300 mil), Programmable, No Battery Warm Mode	PT2283LP
PT2283P-S	8 Pins, SOP (150 mil), Programmed	PT2283P-S
PT2283LP-S	8 Pins, SOP (150 mil), Programmable, No Battery Warm Mode	PT2283LP-S
PT2283P-16	16 Pins, DIP (300 mil), Programmed	PT2283P-16
PT2283P-16S	16 Pins, SOP (150 mil), Programmed	PT2283P-16S