



# PT301EA, PT301ED PWM Speed Controller

## Applications

- Single coil DC brushless motor.
- Traditional double coil DC Brushless motor
- DC 1.5V~6.5V.
- FG(Divide 1) for Four Poles fan
- FG(Divide 2) for Eight Poles fan

## Features

- PWM speed control
- Motor lock protection
- Built-in protection circuit for transient output
- Frequency Generation output
- Low power dissipation and high driving efficiency
- Ultra-low start voltage

## Input Devices

- Hall IC

## Specifications

### Absolute Maximum Ratings (Ta = 25°C)

Parameter	Symbol	Conditions	Ratings	Unit
Maximum supply voltage	V <sub>CC max</sub>		6.5	V
Allowable power dissipation	P <sub>d</sub>		350 <sup>*1</sup>	mW
Operating temperature	T <sub>a</sub>		-30 ~ +100	°C
Storage temperature	T <sub>s</sub>		-55 ~ +150	°C
Output current	I <sub>out max</sub>		400 <sup>*2</sup>	mA

\*1: Reduced by 3.4mW for each increase in Ta of 1°C over 45°C

\* When mounted on a 50mm x 50mm x 1.6mm glass epoxy board.

\*2: Should not exceed Pd.

- ◆ Any and all PROLIFIC products described or contained herein do not have specifications that can handle applications that require extremely high levels of reliability, such as life-support systems, aircraft's control systems, or other applications whose failure can be reasonably expected to result in serious physical and/or material damage. Consult with your PROLIFIC representative nearest you before using any PROLIFIC products described or contained herein in such applications.
- ◆ PROLIFIC assumes no responsibility for equipment failures that result from using products at values that exceed, even momentarily, rated values (such as maximum ratings, operating condition ranges, or other parameters) listed in products specifications of any and all PROLIFIC products described or contained herein.

## Package: SOT-28

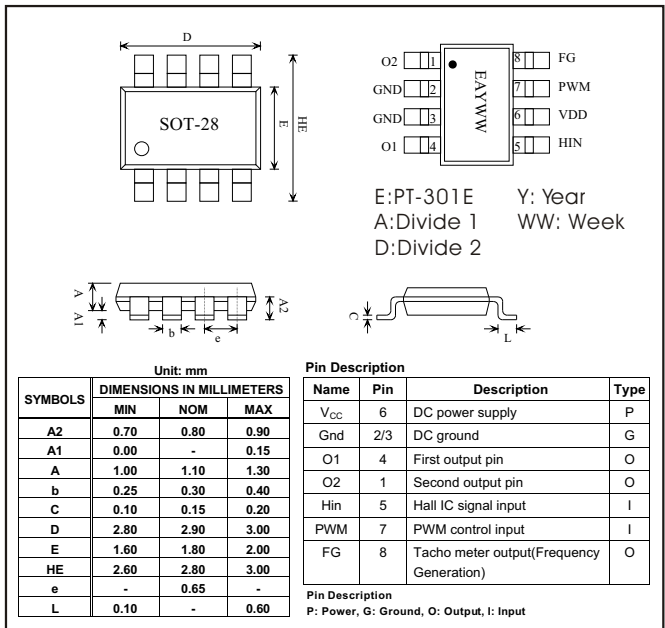

**Recommended operating conditions**

Parameter	Symbol	Min.	Typ.	Max.	Units
Supply Voltage	V <sub>DD</sub>	1.5	5	6.5	V

**Electrical Characteristics(Ta = 25 C,Vdd=5V)**

Parameter	Symbol	Test Condition	Min.	Typ.	Max.	Units
Output Voltage	Low	RL=10@5V		0.48	0.5	V
	High	RL=10@5V	V <sub>DD</sub> -1.1	V <sub>DD</sub> -1		V
Output breakdown voltage				11	12	V
Supply Current		Output open (O1, O2 no load)			10	mA
Driving Current		RL=10@5V	360	379	396	mA
		RL=12@5V	316	330	342	mA
		RL=15@5V	266	276	285	mA
		RL=30@5V	150	153	155	mA
		RL=47@5V	99	100	101	mA
		RL=100@5V	48	49	50	mA
FG supply voltage				11	12	V
FG flow-in current		Pull-high resist or is 470ohm@5V			10	mA
FG output voltage		Pull-high resist or is 470ohm@5V			0.3	V
Hin Input Voltage	High		V <sub>DD</sub> -1.2		V <sub>DD</sub>	V
	Low		GND		0.5	V
Hin input current					100	uA
PWM Input Voltage	High		V <sub>DD</sub> -1.2		V <sub>DD</sub>	V
	Low		GND		0.5	V
PWM Input current					100	uA
PWM Operation Frequency					500	KHz
Motor lock timing	Driving	+/-30%	0.17	0.25	0.33	sec
	Stop	+/-30%	1.22	1.75	2.28	sec

**Rotation Frequency**

The PT301Ex driver IC generates a FG signal for frequency calculation. In general application, the Fan IC will generate a signal to indicate the rotation frequency of different for each motor. When the motor is stopped, the FG signal will pull high to indicate the stop of the motor was stopped.

**Digital PWM Speed Control**

PT301Ex applies the Pulse Width Modulation (PWM) to control motor speed. PT301Ex can use the PWM input pin to control the motor speed. When the PWM is high, the driver IC will drive the motor coil. On the other hand, when the PWM is low, the driver IC will stop driving the motor coil.

PWM	HIN	O1	O2
High	High	Low	High
	Low	High	Low
Low	High	Low	Low
	Low	Low	Low

**Lock Protection**

In order to protect the motor and reduce the power dissipation. When the motor contacts the outside force, the Fan IC will stop driving the coil after the motor is lock over 0.25 seconds and restart the motor after stop the motor 1.75 seconds. Figure 2 shows the timing diagram between the hall input signal and driver state. Whenever the motor stops for 0.25 second by outside force, the Fan IC will shut down stop the driving output, and after 1.75 seconds, the Fan IC will turn on again.

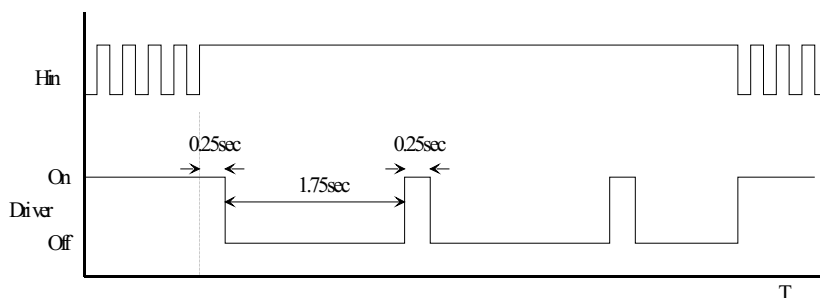

Fig 2. Lock Protection

The driver IC architecture block diagram is showed as Figure-3

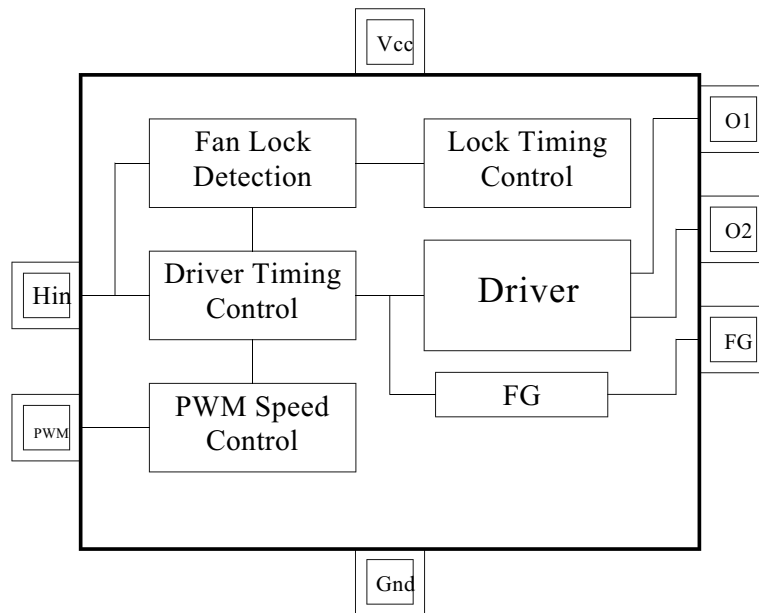
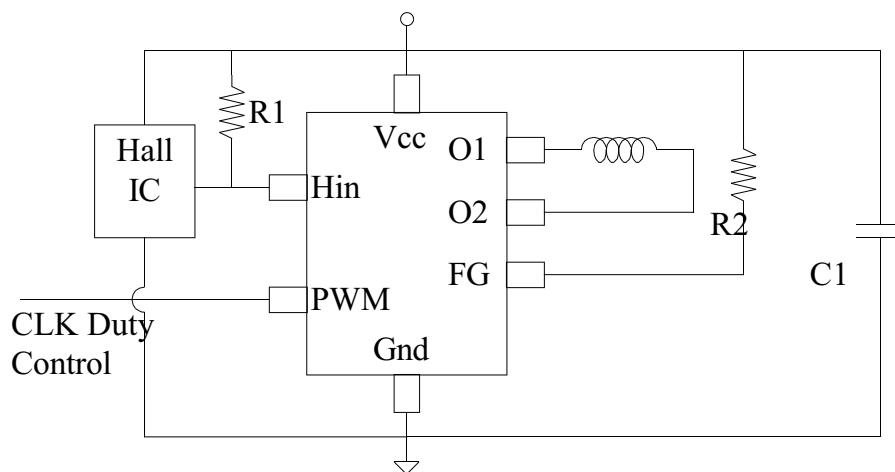

Fig. 3. Driver IC Architecture

### Application circuits

#### 1. Signal coil



R1: Depend on the Hall IC spec.  
 R2: 470 ohm ~ 4.7K ohm  
 C1: 0.22uf<sub>(Optional)</sub>

**Application circuits**

**2. Double coil**

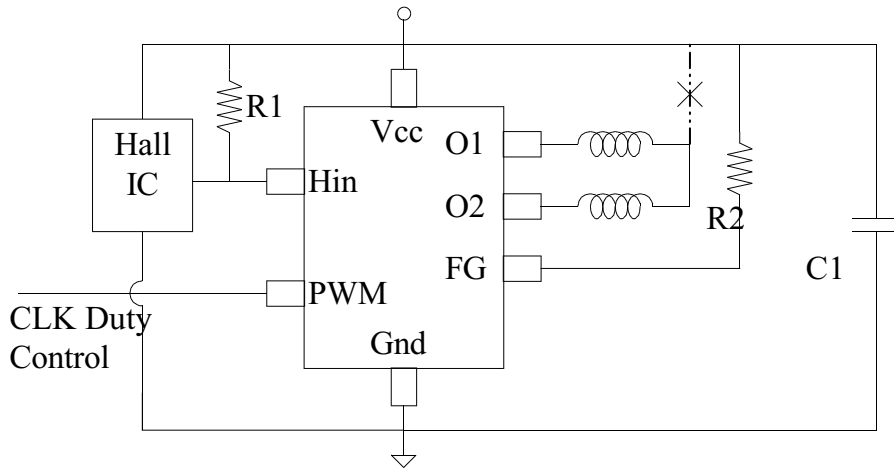

R1: Depend on the Hall IC spec.  
 R2: 470 ohm ~ 4.7K ohm  
 C1: 0.22uf  
 (Optional)

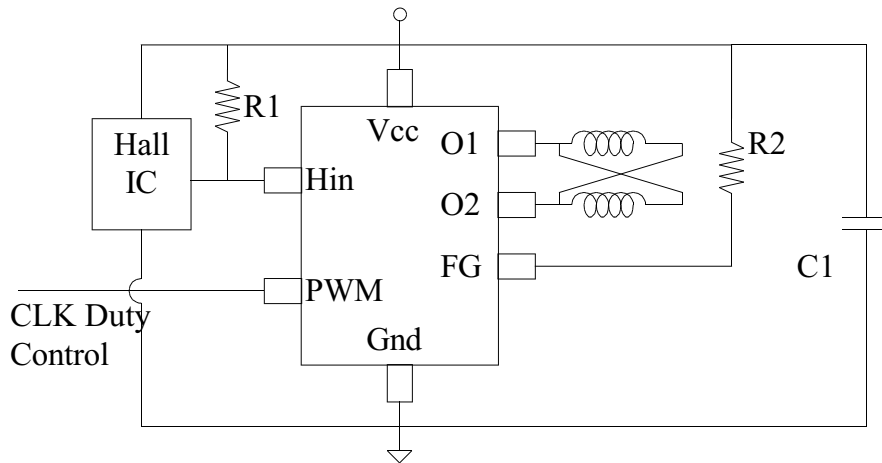

R1: Depend on the Hall IC Specification  
 R2: 470 ohm ~ 4.7K ohm  
 C1: 0.22uf  
 (Optional)

### Application circuits

#### High driving application:

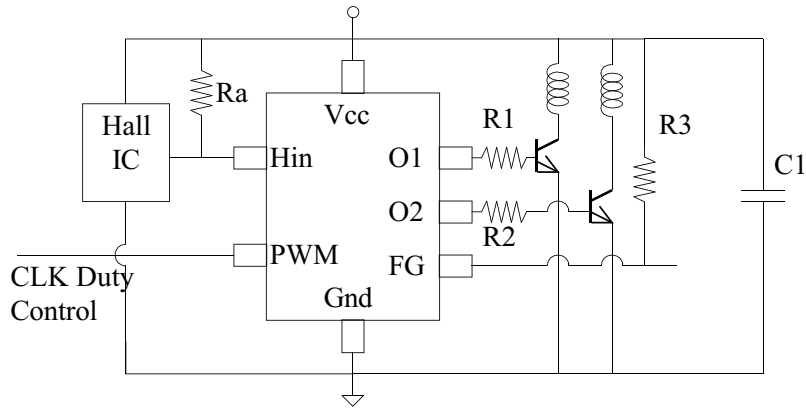

Ra: Depend on the Hall IC Specification  
 R1, R2: Depend on driving current  
 R3: 470 ohm ~ 4.7K ohm  
 C1: 0.22uf (optional)

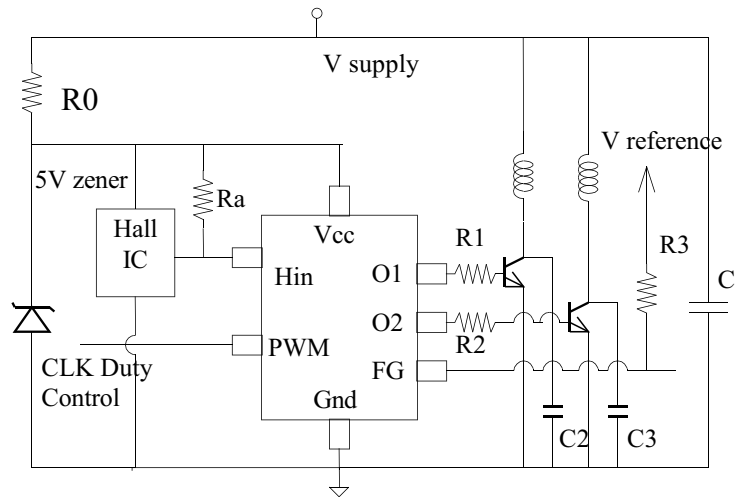

Ra: Depend on the Hall IC Specification  
 R0: Depend on the power dissipation and the driving ability  
 R1, R2: Depend on the external NPN driving ability  
 R3: 470 ohm ~ 4.7K ohm  
 C1: 0.22uf (optional)  
 C2, C3: 0.22u~5u (optional)

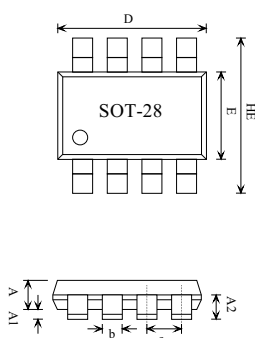

Unit: mm

SYMBOLS	DIMENSIONS IN MILLIMETERS		
	MIN	NOM	MAX
A2	0.70	0.80	0.90
A1	0.00	-	0.15
A	1.00	1.10	1.30
b	0.25	0.30	0.40
C	0.10	0.15	0.20
D	2.80	2.90	3.00
E	1.60	1.80	2.00
HE	2.60	2.80	3.00
e	-	0.65	-
L	0.10	-	0.60

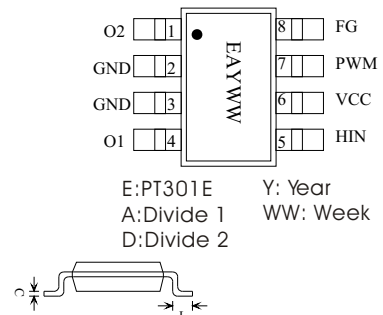

E:PT301E    Y: Year  
A:Divide 1    WW: Week  
D:Divide 2

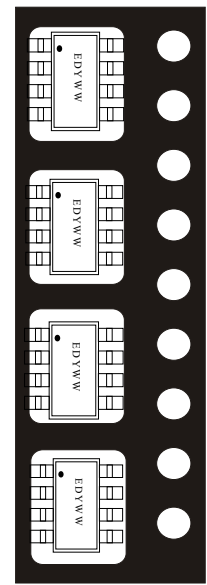

**Pin Description**

Name	Pin	Description	Type
V <sub>CC</sub>	6	DC power supply	P
Gnd	2/3	DC ground	G
O1	4	First output pin	O
O2	1	Second output pin	O
Hin	5	Hall IC signal input	I
PWM	7	PWM control input	I
FG	8	Tacho meter output(Frequency Generation)	O

Pin Description  
P: Power, G: Ground, O: Output, I: Input

3000pcs./Reel