

## DESCRIPTION

The PT32M625 is a SiP (System in Package) with mcu PT32U301 and a motor gate driver PT5619. The PT32M625 microcontroller is a series of low-power microcontroller incorporating a high-performance ARM Cortex™-M0 32-bit RISC core. It operates at a maximum 48MHz frequency and features up to 32Kbytes of Flash and up to 4Kbytes of SRAM. The PT5619 is a high-speed 3-phase gate driver for power MOSFET and IGBT devices with three independent high and low side referenced output channels. Built-in dead time protection and shoot-through protection prevent damage to the half-bridge.

## FEATURES

- ARM Cortex M0 Processor
- Performance up to 48 MHz
- Flash Memory 32K-Byte
- System SRAM 4K-Byte
- PWM Mode control logic
- PT5619
  - 90V half-bridge high side driver
  - Driver up to 3-phase half-bridge gates
  - Built-in dead time control 0.5µs (typ.)
  - Shoot-through protection
  - Common-mode dV/dt noise cancellation circuit
  - Tolerant of negative transient voltage

## BLOCK DIAGRAM

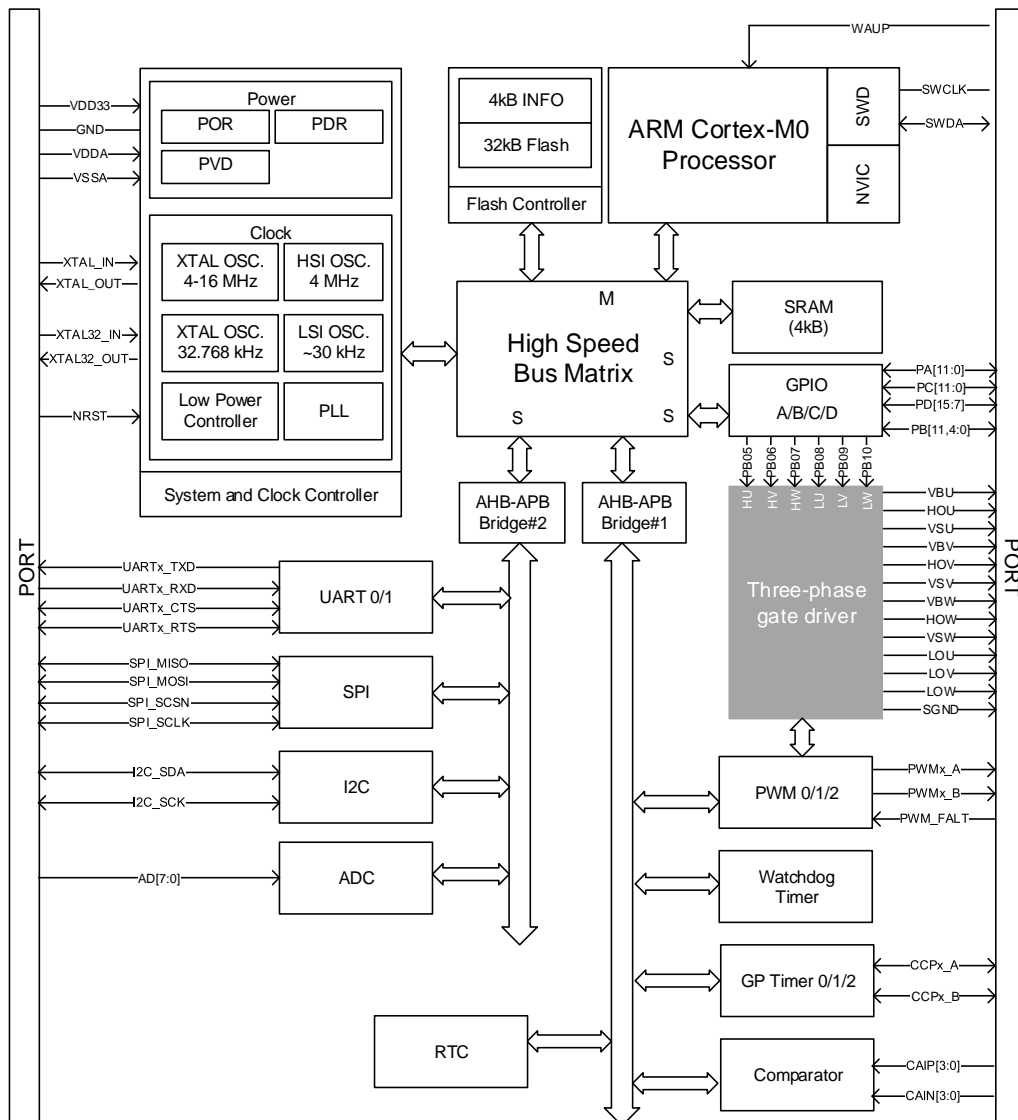

## 1. ORDER INFORMATION

Valid Part Number	Package Type	Top Code
PT32M625-LQ	LQFP 48	PT32M625-LQ

## 2. PIN CONFIGURATION

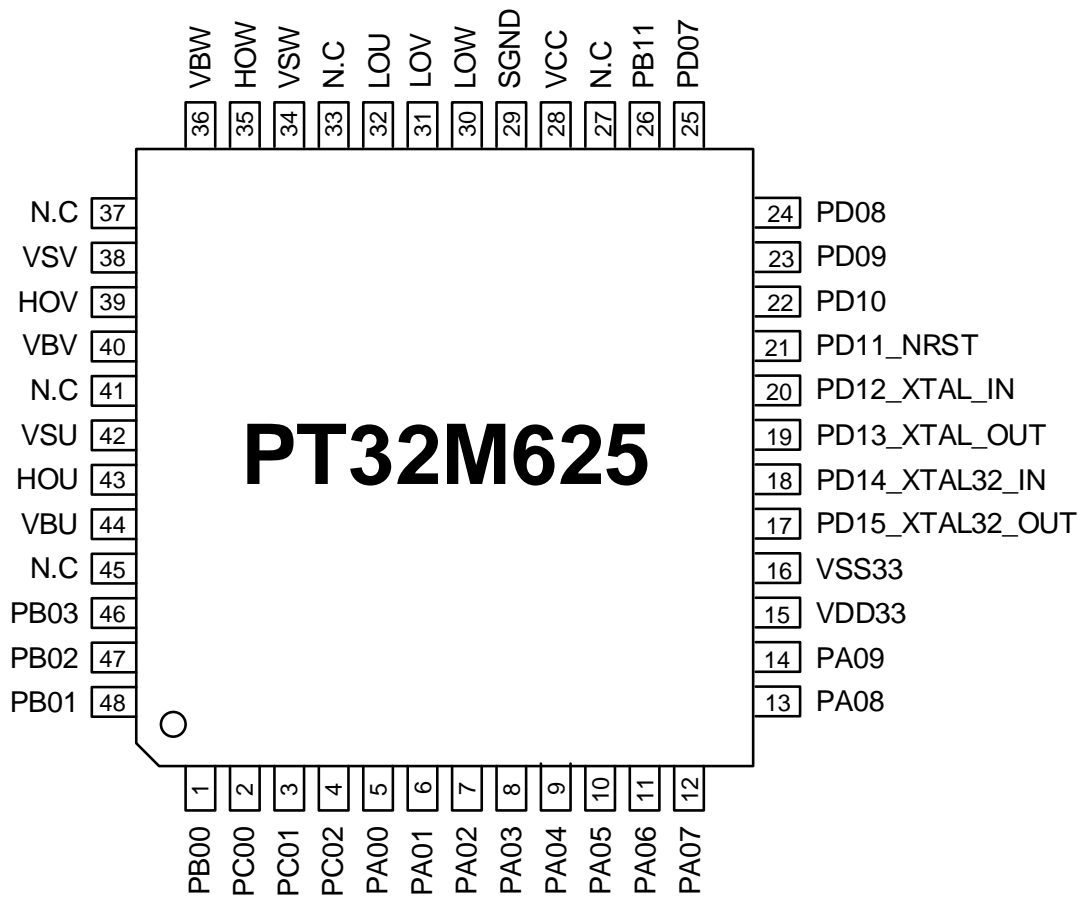

### 3. PIN DESCRIPTION

Each GPIO line can be assigned to one of the peripheral functions. The following table lists out the pin name of all packages and its respective available alternate function.

Pin Name	Pin Type	Description	Pin No.
PB00	I/O	General Purpose Digital I/O Pin	1
PC00	I/O	General Purpose Digital I/O Pin	2
PC01	I/O	General Purpose Digital I/O Pin	3
PC02	I/O	General Purpose Digital I/O Pin	4
PA00	I/O	General Purpose Digital I/O Pin	5
PA01	I/O	General Purpose Digital I/O Pin	6
PA02	I/O	General Purpose Digital I/O Pin	7
PA03	I/O	General Purpose Digital I/O Pin	8
PA04	I/O	General Purpose Digital I/O Pin	9
PA05	I/O	General Purpose Digital I/O Pin	10
PA06	I/O	General Purpose Digital I/O Pin	11
PA07	I/O	General Purpose Digital I/O Pin	12
PA08	I/O	General Purpose Digital I/O Pin	13
PA09	I/O	General Purpose Digital I/O Pin	14
VDD33	Supply	3.3V Voltage Supple	15
VSS33	Ground	Ground	16
PD15_XTAL32_OUT	I/O	General Purpose Digital I/O Pin	17
PD14_XTAL32_IN	I/O	General Purpose Digital I/O Pin	18
PD13_XTAL_OUT	I/O	General Purpose Digital I/O Pin	19
PD12_XTAL_IN	I/O	General Purpose Digital I/O Pin	20
PD11_NRST	I/O	General Purpose Digital I/O Pin	21
PD10	I/O	General Purpose Digital I/O Pin	22
PD09	I/O	General Purpose Digital I/O Pin	23
PD08	I/O	General Purpose Digital I/O Pin	24
PD07	I/O	General Purpose Digital I/O Pin	25
PB11	I/O	General Purpose Digital I/O Pin	26
N.C.	-	No Connection	27, 33, 37, 41, 45
VCC	Supply	Voltage Supply	28
SGND	Ground	Logic Ground And Low-Side Gate Drivers Ground	29
LOW	O	Phase-W Low-Side Gate Driver Output	30
LOV	O	Phase-V Low-Side Gate Driver Output	31
LOU	O	Phase-U Low-Side Gate Driver Output	32
VSW	Supply	Phase-W High-Side Driver Floating Supply Offset Voltage	34
HOW	O	Phase-W High-Side Driver Output	35
VBW	Supply	Phase-W High-Side Driver Floating Supply	36
VSV	Supply	Phase-V High-Side Driver Floating Supply Offset Voltage	38
HOV	O	Phase-V High-Side Driver Output	39
VBV	Supply	Phase-V High-Side Driver Floating Supply	40
VSU	Supply	Phase-U High-Side Driver Floating Supply Offset Voltage	42
HOU	O	Phase-U High-Side Driver Output	43
VBU	Supply	Phase-U High-Side Driver Floating Supply	44
PB03	I/O	General Purpose Digital I/O Pin	46
PB02	I/O	General Purpose Digital I/O Pin	47
PB01	I/O	General Purpose Digital I/O Pin	48

## **IMPORTANT NOTICE**

Princeton Technology Corporation (PTC) reserves the right to make corrections, modifications, enhancements, improvements, and other changes to its products and to discontinue any product without notice at any time.

PTC cannot assume responsibility for use of any circuitry other than circuitry entirely embodied in a PTC product. No circuit patent licenses are implied.

Princeton Technology Corp.  
2F, 233-1, Baociao Road,  
Sindian, Dist., New Taipei City 23145, Taiwan  
Tel : 886-2-66296288  
Fax: 886-2-29174598  
<http://www.princeton.com.tw>