

GENERAL DESCRIPTION

The PT4112 is a step-up converter with current sources capable of driving six parallel strings of up to 10 series-connected WLEDs. Each string is terminated with ballast that achieves $\pm 1.5\%$ current regulation accuracy, ensuring even brightness for all WLEDs. The PT4112 generates an output voltage to drive up to totally 60 WLEDs from a 5V to 25V input source; in addition, the output voltage is automatically adjusted to WLED forward voltage to achieve good efficiency.

The PT4112 supports pulse width modulation (PWM) brightness dimming. A PWM signal input on the BRT pin could directly turn LED lights on/off. By freezing the circuit state during dimming off stage, the AC ripple on output ceramic capacitors is minimized across a wide duty cycle range; therefore reduce the potential audible noise.

The PT4112 has multiple features to protect itself from fault conditions including built-in open lamp over voltage protection, cycle-by-cycle current limit, over temperature shutdown, input under voltage lock out and integrated soft-start. Additionally, PT4112 provides a driver output for an external PFET connected between the input and inductor. The PFET will be turned off by PT4112 to disconnect the battery from the WLEDs when severe error happens thus any leakage current of the battery is prevented.

TYPICAL APPLICATIONS

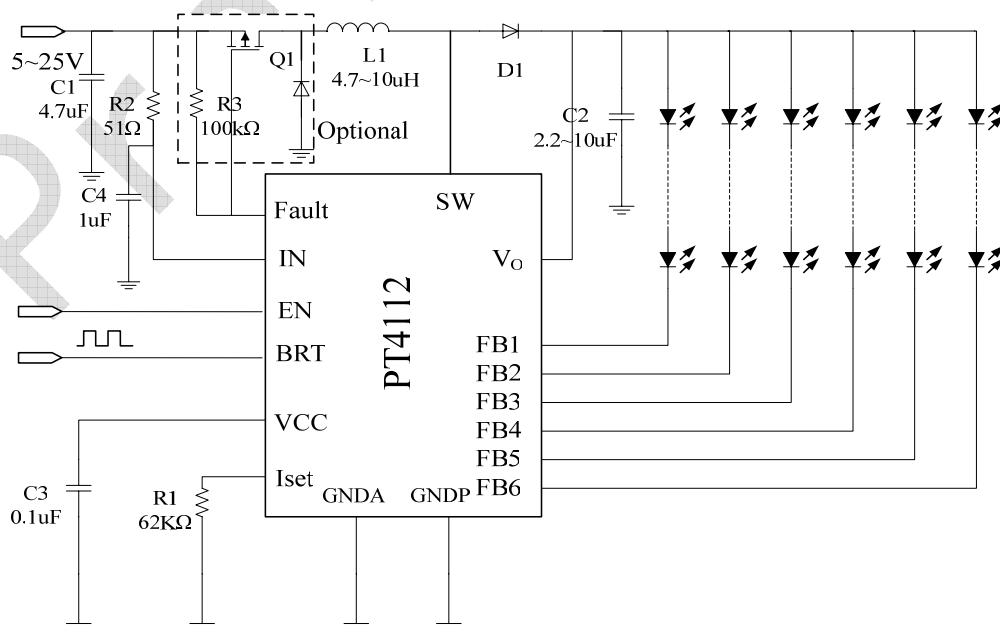

FEATURES

- 5V to 25V wide input voltage range
- 1.2MHz switch frequency with dithering
- Integrated 1.5A 40V MOSFET
- Six-channel current sink adjustable from 15mA to 25mA
- $\pm 1.5\%$ current accuracy between strings
- 100:1 PWM dimming range
- Boost output voltage auto-adjust to maximum forward voltage LED string
- Small external components
- Cycle by cycle current limiting
- Built in soft start
- Open/Short lamp self protection
- Current auto-adjust when open lamp detected
- Drive for input/output isolation PFET
- 16 pin 3x3 QFN package

APPLICATIONS

- Notebook LCD display Backlight
- General middle-sized LCD backlight

PIN ASSIGNMENT

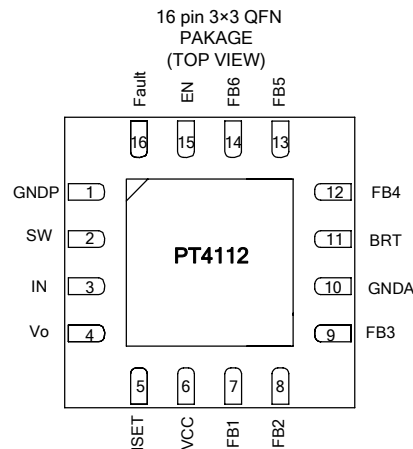

PIN DESCRIPTIONS

PIN NUM	PIN NAME	DESCRIPTIONS
1	GNDP	Power ground of the IC. It connects the source of the internal PWM switch
2	SW	Switch Output. SW is the drain of the internal N-Ch MOSFET switch
3	IN	Input Supply Pin. Must be locally bypassed.
4	Vo	Open Load Sensing Pin. Senses regulator output voltage to protect IC during open load operation.
5	ISET	Connect a resistor on this pin to program LED current
6	VCC	IC Internal Supply Pin. It is the output of the internal LDO. Connect a 0.1uF bypass capacitor to this pin.
7, 8, 9, 12, 13, 14	FB1~FB6	LED String Current Control Input. Connect the bottom (Cathode) of the LED string to it.
10	GNDA	Signal Ground of the IC.
11	BRT	Dimming Control Logic Input. The dimming frequency range is 100Hz to 1KHz.
15	EN	The Chip Enable Pin. Input logic high level turns on the IC.
16	Fault	Fault Protection Output Pin. This pin drive an external PFET or used as system fault report signal.

ABSOLUTE MAXIMUM RATINGS (NOTE1)

SYMBOL	ITEM	RATING	UNIT
V _{IN}	Voltage on IN pin	-0.3~25	V
V _{FAULT}	Voltage on FAULT pin	-0.3~25	V
V _{CC}	Voltage on VCC pin	-0.3~5.5	V
V _{SW}	Voltage on SW pin	-0.3~40	V
V _o	Voltage on Vo pin	-0.3~40	V
V _{FB1~6}	Voltage on FB1-FB6 pin	-0.3~30	V
V _{IO}	Voltage on other pins	-0.3~5.5	V
T _J	Operating junction temperature	-40~150	°C
T _{STG}	Storage temperature	-65~150	°C

RECOMMENDED OPERATING RANGE (NOTE2)

SYMBOL	PARAMETER	VALUE
V _{IN}	Operating working voltage	5V-25V
V _O	Output voltage range	V _{IN} -38V
L	Inductor	4.7-10uH
C _I	Input capacitor	1uF
C _O	Output capacitor	2.2-10uF
F _{PWM}	PWM dimming frequency	0.1-1kHz
T _A	Operation ambient temperature	-40-85 °C
T _J	Operation junction temperature	-40-125 °C

Notes:

- Exceeding these ratings may damage the device.
- The device is not guaranteed to function outside of its operating ratings.

ELECTRICAL CHARACTERISTICS

V_{IN} = 10.8V, 0.1uF at VCC, EN = Logic High, IFB current=20mA, IFB voltage=500mV, T_A = 25°C.
(Unless otherwise specified).

SYMBOL	PARAMETER	CONDITIONS	MIN	TYP	MAX	UNITS
VIN and VCC						
V _{IN}	V _{IN} Supply Voltage		5		25	V
I _{IN} (OFF)	Supply Current (Shutdown)	V _{EN} <0.4V		5	20	μA
I _{IN} (ON)	Supply Current (Quiescent)	V _{EN} >1.2V, V _{FB} =0.5V			6	mA
V _{IN_UVLO}	V _{IN} UVLO Threshold Voltage	V _{IN} Ramp Down			4.3	V
V _{IN_HYS}	V _{IN} UVLO Hysteresis	V _{IN} Ramp Up		500		mV
V _{CC}	Voltage at VCC			5		V
Oscillator						
F _{OSC}	Oscillation Frequency		1.0	1.2	1.4	MHz
D _{MAX}	SW Maximum Duty Cycle		90	95		%
D _{MIN}	SW Minimum Duty Cycle			7		%
EN and BRT						
V _H	Logic input High level		1.2			V
V _L	Logic input Low level				0.4	V
R _{PD}	Pull down resistor on both pins		400	800	1600	KΩ
Internal Power Switch						
R _{DSON}	SW Switch On Resistance			0.20	0.45	Ω
I _{LEAK_SW}	SW Switch Leakage Current	V _{EN} =0V, V _{SW} = 35V			1	μA
I _{LIMIT}	SW Switch Current Limit			1.5	3	A
R _{ostart}	Start Up Charging Resistance			300		Ω
V _{ostart}	Vo Start Up Threshold	V _{IN} -V _O , V _O Ramp Up		1.7	2.5	V

ELECTRICAL CHARACTERISTICS

SYMBOL	PARAMETER	CONDITIONS	MIN	TYP	MAX	UNITS
Current Regulation						
V _{ISET}	ISET Pin Voltage			1.24		V
I _{FB}	FB Current Accuracy	R _{ISET} =62K	19.4	20	20.6	mA
I _{FB_MAT}	FB Current Match $\Delta I_{max}/I_{AVG}$	R _{ISET} =62K, D _{BRT} =100%	-1.5		+1.5	%
I _{FB_LEAK}	FB Leakage Current	V _{FB1-6} =20V, V _{EN} =0			3	uA
V _{IFB_L}	V _O dial up threshold	Measured on V _{IFB(min)}		500		mV
V _{IFB_H}	V _O dial down threshold	Measured on V _{IFB(min)}		800		mV
Open and Short Protection						
V _{OVP}	V _O Over Voltage Threshold		38	39	42	V
V _{OVP_FB}	FB Over Voltage Threshold		15	17	20	V
V _{SHORT}	Short Circuit Detection Threshold	V _{IN} -V _O , V _O Ramp Down		1.7	2.5	V
T _{SHORT}	Short Circuit Detection Delay During Start Up			32		mS
Fault Output						
V _{FAULT_HITH}	Fault high voltage	V _{IN} -V _{FAULT}		0.1		V
V _{FAULT_LOW}	Fault low voltage	V _{IN} -V _{FAULT} V _{IN} =15V, I _{FAULT} =0.1mA	6	8	10	V
Thermal Shutdown						
T _{TSD}	Thermal Shutdown Threshold			160		°C
T _{HYS}	Thermal Shutdown Hysteresis			15		°C

SIMPLIFIED BLOCK DIAGRAM

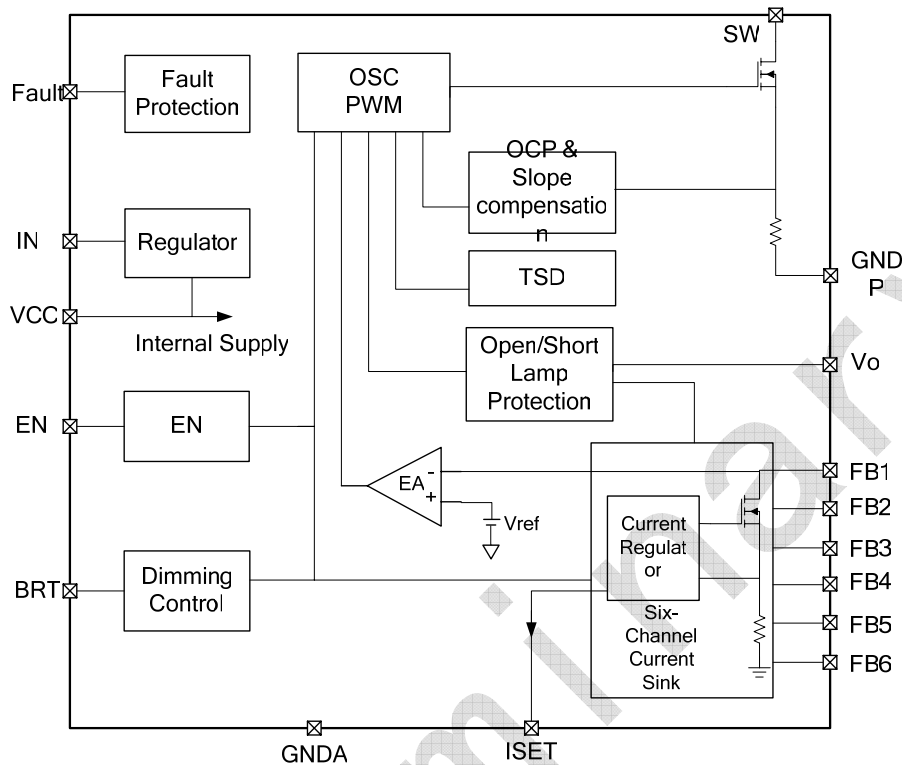

OPERATION DESCRIPTION

Start up and shutdown:

A logic high voltage applying to EN turns the IC on. For PT4112 ICs, internal LDO will be turned on firstly, and provides supply IC current. Then pins IFBx will be detected to see whether these pins are shorted to ground. After detection, output capacitor will be charged through the resistor R_{start} between pin IN and Vo from input voltage. At the moment, voltage at Fault is equal to V_{IN} , and it will not be pulled down to turn on external PFET and connect the V_{IN} voltage to the boost regulator until output voltage reaches $V_{IN}-2V$. At this moment, R_{start} route to charge Vout is stopped. Then the IC starts the PWM switching to raise the output voltage above V_{IN} with soft-start mode. During whole start up procedure, there is no in-rush current due to charging the output capacitor. Pulling the EN pin low for 32ms (typical) shuts down the IC, resulting in the IC

consuming less than 20uA in the shutdown mode.

Opening detection and OVP:

When minimum voltage at IFBx is smaller than 0.5V, the reference voltage in chip will be dialed up, and the output voltage will rise until OVP is triggered. Then pins IFBx will be detected to see whether is larger than 0.2V. If not, the current string will be turned off. If minimum voltage at IFBx is in the range of 0.2~0.5V, the chip will work at OVP state. If the current string opening is detected, the current value of other strings will be added by 20% to reduce the impact of total current reduction.

Over voltage protection for IFBx:

When there is great mismatch of LED forward voltage between different current strings, or the number of

LEDs is different between different current strings, once voltage at IFBx is greater than 17V, the current string will be turned off to avoid large power consuming in chip.

Three kinds over current protection:

1. Normal over current protection during working (OCP)

Over current will be detected cycle by cycle during working. Once the current of switch is greater than 1.5A, the switch will be turned off in the rest time of cycle. If over current is detected continuously for 16ms, the chip will be turned off. It needs input power-on reset or EN pin logic reset to restart the chip.

2. Severe over current protection during working (OLP)

If output voltage value is 1.7V smaller than input voltage value, the voltage at Fault pin will go high, then isolation FET will be turned off, and then the chip will be turned off. It needs input power-on reset or EN pin logic reset to restart the chip.

3. Vout shorted to ground protection during start up (OSP)

During start up course, if output voltage isn't charged to $V_{IN}-2V$ in 32ms, the chip will be turned off. It needs input power-on reset or EN pin logic reset to restart the chip.

IFB pin unused:

If the application requires less than 6 WLED strings, the unused IFB pin is expected to short to ground. During start up course, short to ground detection will be performed, and the unused string will be disabled. If there is an open current string, output voltage will go up to over voltage threshold. Then opening detection will

be performed, and the open string will be disabled, and the current value of other strings will be added by 20% to reduce the impact of total current reduction. If all of the strings are disabled, the chip will be turned off.

Current program and PWM dimming:

The six current sink regulator can each provide maximum 25mA. The current value of each string can be calculated by using the following equation:

$$I_{FB} = \frac{20mA \times 62k\Omega}{R_{ISET}}$$

where R_{ISET} is ISET pin resistor.

The current mismatch among 6 current strings is 1.5%. This means the differential value between maximum and minimum current of six current sinks divided by the average current of six is less than 1.5%. The average current of WLED can be program by applying PWM signal to BRT pin. After transmitting into chip, PWM signal will be synchronized by internal clock, then the synchronized PWM is used to control the six current sinks. The frequency of PWM signal is expected to be in the range of 100Hz~1kHz, so that screen flickering can be avoided and dimming linearity can be maintained. When the frequency of PWM signal is below 100Hz, screen flickering may occur. Though the PT4112 IC is designed to minimize the AC ripple on the output capacitor during PWM dimming, careful passive component selection is also critical. In addition, in order to reduce the power consumption when the voltage at BRT is low, the switching frequency at SW will be reduced by system.

PACKAGE INFORMATION

QFN16(3x3mm²)

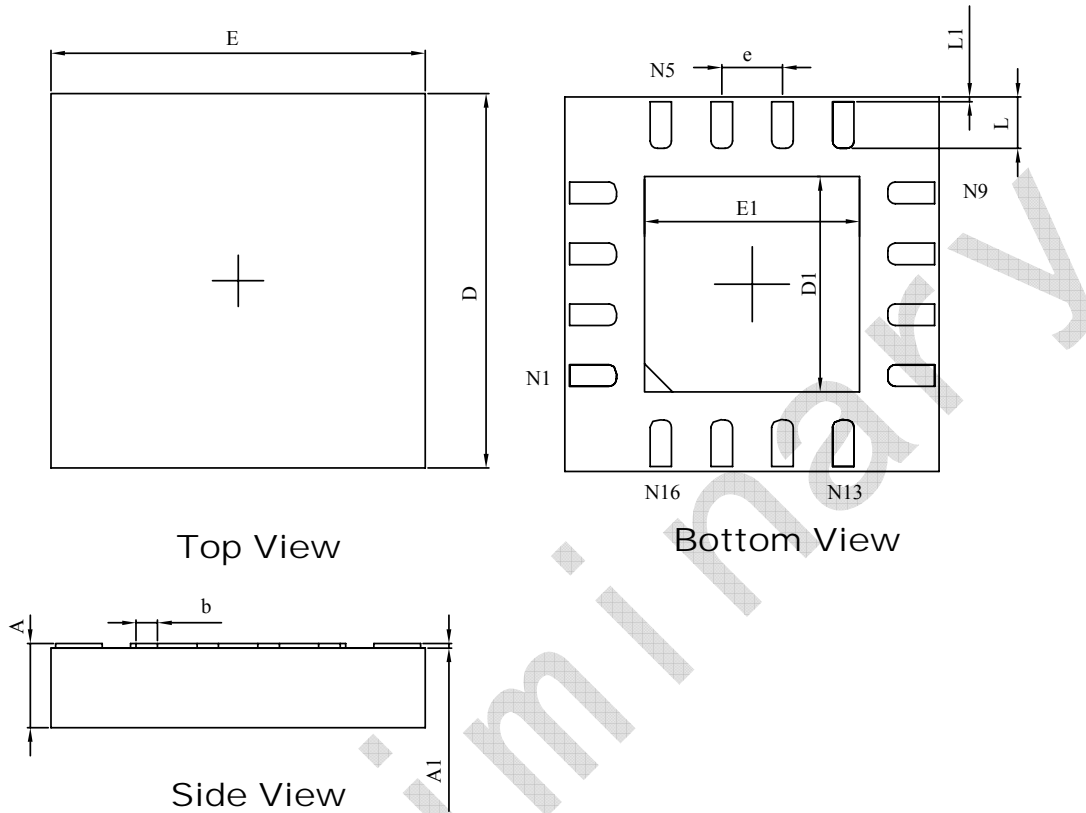

SYMBOL	MILLIMETERS		INCHES	
	MIN	MAX	MIN	MAX
A	0.000	0.900	0.000	0.035
A1	0.010	0.090	0.000	0.004
D	2.900	3.100	0.114	0.122
E	2.900	3.100	0.114	0.122
D1	1.700 REF.		0.067 REF.	
E1	1.700 REF.		0.067 REF.	
b	0.150	0.250	0.006	0.010
e	0.500 BSC.		0.020 BSC.	
L	0.350	0.450	0.014	0.018
L1	0.000	0.050	0.000	0.002