

### DESCRIPTION:

PT4203 is targeted to below 10W LED lighting applications. It is designed for the flyback topology, and regulates output current without the secondary feedback loop.

The PT4203 provide accurate CC (constant current) regulation with built in compensation circuitry. Integrated line and primary inductance compensation ensures output current free of line voltage and primary inductance variations.

Complete protection functions have been integrated allows PT4203 to protect against all fault conditions including cycle by cycle current limit, output open/short circuit, line under-voltage, and over temperature shut down.

PT4203 is available in SOT23-5 package.

### FEATURES

- CC Control Without Secondary Feed back
- Compensates transformer Inductor Variation
- Compensates Line Voltage Variation
- Drive NPN or DN MOS
- Output Over Voltage Protection
- Output Short Circuit Protection
- Feedback resistor open circuit protection
- Line Under Voltage Protection
- Cycle by Cycle Current Limit
- Over Temperature Protection

### APPLICATIONS

- 1-10W LED Power Supplier

### ORDERING INFORMATION

PACKAGE	TEMPERATURE RANGE	ORDERING PART NUMBER	TRANSPORT MEDIA	MARKING
SOT23-5	-40°C to 85°C	PT4203E23E	Tape and Reel	4203

### TYPICAL APPLICATION CIRCUIT

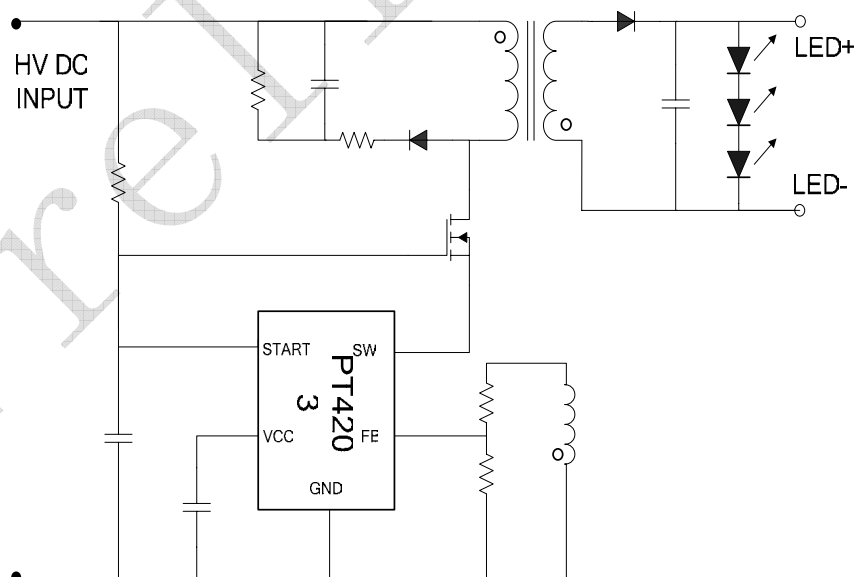

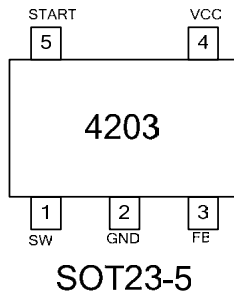
**PIN ASSIGNMENT**

**PIN DESCRIPTIONS**

NO.	PIN NAME	DESCRIPTION
1	SW	Internal switch driver output, connects to the source of MOSFET
2	GND	System ground
3	FB	Feedback Winding Voltage Sense Input
4	VCC	DC power supply pin, must be locally bypassed
5	START	Start up control pin, connects to the gate of the MOSFET, must be locally bypassed

**ABSOLUTE MAXIMUM RATINGS (note 1,2,3)**

SYMBOL	PARAMETER	VALUE	UNIT
V <sub>CC</sub>	VCC supply voltage	-0.3~6	V
START	START input voltage	-0.3~15	V
SW	SW output voltage	-0.3~30	V
FB	FB input voltage	-0.3~6	V
P <sub>DMAX</sub>	Power dissipation (note 2)	0.27	W
P <sub>TR1</sub>	Heat resistance R <sub>θJA</sub>	250	°C/W
T <sub>J</sub>	Junction temperature	-40 to 150	°C
T <sub>STG</sub>	Storage temperature	-55 to 150	°C
HBM	ESD sensitivity level (note 3)	3	kV

**RECOMMENDED OPERATING CONDITION**

SYMBOL	PARAMETER	VALUE	UNIT
V <sub>CC</sub>	supply voltage	5.5	V
T <sub>OPT</sub>	Operating ambient temperature	-40 to +85	°C

**Note 1:** Absolute Maximum Ratings indicate limits beyond which damage to the device may occur. Recommended Operating Range indicates conditions for which the device is functional, but do not guarantee specific performance limits. Electrical Characteristics state DC and AC electrical specifications under particular test conditions which guarantee specific performance limits. This assumes that the device is within the Operating Range. Specifications are not guaranteed for parameters where no limit is given, however, the typical value is a good indication of device performance.

**Note 2:** The maximum power dissipation must be derated at elevated temperatures and is dictated by T<sub>JMAX</sub>, θ<sub>JA</sub>, and the ambient temperature T<sub>A</sub>. The maximum allowable power dissipation is P<sub>DMAX</sub> = (T<sub>JMAX</sub> - T<sub>A</sub>) / θ<sub>JA</sub> or the number given in Absolute Maximum Ratings, whichever is lower.

**Note 3:** Human body model, 100pF discharged through a 1.5kΩ resistor.

**ELECTRICAL CHARACTERISTICS**

 (T<sub>A</sub>=25°C, V<sub>CC</sub>=5.5V, unless specified otherwise)

SYMBOL	PARAMETER	TEST CONDITION	MIN	TYP	MAX	UNIT
<b>VCC Supply and Start up (VCC and START)</b>						
V <sub>START_ON</sub>	START on threshold	START rising	9	11	13	V
V <sub>START_OFF</sub>	START off threshold	START falling	5.5	7.5	9.5	V
V <sub>START_CLMP</sub>	START clamp voltage	I(V <sub>START</sub> )=5mA	11.5	13	14.5	V
V <sub>CC</sub>	VCC operating voltage			6		V
V <sub>CC_CLMP</sub>	VCC clamp voltage	I(V <sub>CC</sub> )=5mA		6.5		V
V <sub>CC_UVLO</sub>	VCC UVLO threshold	VCC falling	4.0	4.5	5	V
I <sub>CH</sub>	VCC charge current	V <sub>CC</sub> =0V, V <sub>sw</sub> =20V	-7.5	-5	-2.5	mA
<b>Feedback (FB)</b>						
V <sub>FBMAX</sub>	FB over voltage threshold		2.25	2.5	2.75	V
V <sub>FBMIN</sub>	FB minimum voltage			0.50		V
I <sub>FB_OPEN</sub>	FB open loop protection threshold			-120		uA
<b>OSCILLATOR</b>						
F <sub>osc</sub>	Oscillator frequency	FB=2.25V, I <sub>FB</sub> ×Ton=1.5mA*uS	60	65	70	kHz
Dither_osc	Oscillator frequency modulation ratio	T <sub>J</sub> =25°C		± 7		%
D <sub>MAX</sub>	Maximum duty cycle			60		%
<b>Driver output (SW)</b>						
R <sub>DS(ON)</sub>	SW On state resistance	T <sub>J</sub> =25°C		3.5	5	Ω
<b>Protection</b>						
I <sub>LIMIT</sub>	SW peak current	di/dt=100 mA/us	381	410	438	mA
T <sub>LEB</sub>	Leading edge blanking time			300		ns
T <sub>SD</sub>	Over temperature shut down threshold			150		°C
T <sub>SDHYS</sub>	Over temperature shut down hysteresis			50		°C
T <sub>AR_ON</sub>	Fault condition restart time			4		S

### SIMPLIFIED BLOCK DIAGRAM

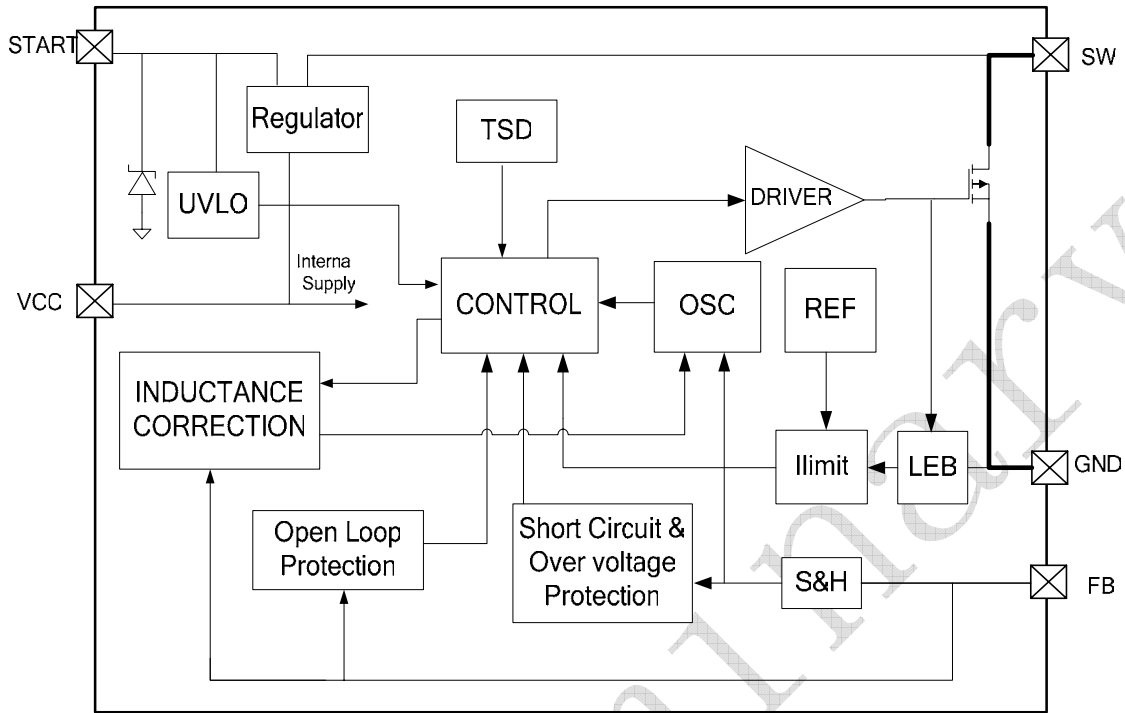

### PACKAGE INFORMATION

#### SOT23-5 Package

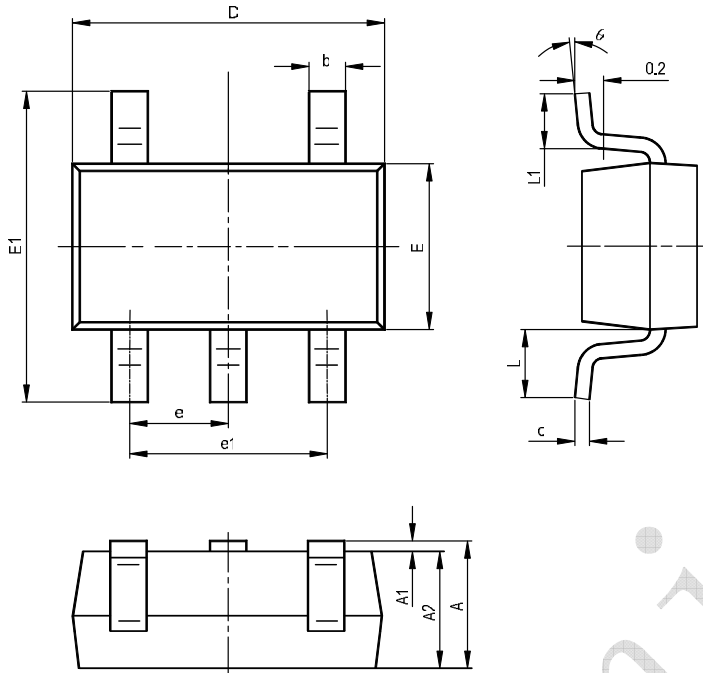

Symbol	Millimeters		Inches	
	Min	Max	Min	Max
A	1.050	1.250	0.041	0.049
A1	0.000	0.100	0.000	0.004
A2	1.050	1.150	0.041	0.045
b	0.300	0.400	0.012	0.016
c	0.100	0.200	0.004	0.008
D	2.820	3.020	0.111	0.119
E	1.500	1.700	0.059	0.067
E1	2.650	2.950	0.104	0.116
e	0.950TYP		0.037TYP	
e1	1.800	2.000	0.071	0.079
L	0.700REF		0.028REF	
L1	0.300	0.600	0.012	0.024
$\theta$	0°	8°	0°	8°