

GENERAL DESCRIPTION

The PT4209 is a flicker-free PWM/analog dimmable, primary side constant current controller which can achieve high power factor in a single stage converter, targeted to applications in solid state lighting. It is designed for the flyback topology, and regulates output current accurately without the secondary feedback loop.

PT4209 works in quasi-resonant mode to reduce the MOSFET switching loss. The device uses extremely low startup and low quiescent current to achieve high efficiency.

A complete set of integrated protection functions allows the PT4209 to protect against all fault conditions such as VCC under-voltage, VCC over-voltage, cycle by cycle current limit, output open/short circuit, Rcs open circuit, transformer winding short circuit and over temperature shut down.

The PT4209 is available in SOP8 package.

FEATURES

- Constant Current Control Without Secondary Feed back
- Flicker-free PWM/analog Dimming (10%-100%)
- Accurate Constant Current Output
- Quasi-Resonant Mode Operation
- Ultra-low (10uA) Start Up Current
- Low Quiescent Current (1mA)
- VCC Under Voltage Protection
- Over Voltage Protection by Voltage Holding
- Cycle by Cycle Current Limit
- Rcs Open Circuit Protection
- Transformer Winding Short Circuit Protection
- Output Open/Short Circuit Protection
- Over Temperature Protection

APPLICATIONS

- Solid State Lighting
- Industrial and Commercial Lighting
- Residential Lighting

ORDERING INFORMATION

PACKAGE	TEMPERATURE RANGE	ORDERING PART NUMBER	TRANSPORT MEDIA	MARKING
SOP-8	-40°C to 85°C	PT4209ESOH	3000/Tape and Reel	PT4209 xxxxxX

TYPICAL APPLICATION CIRCUIT

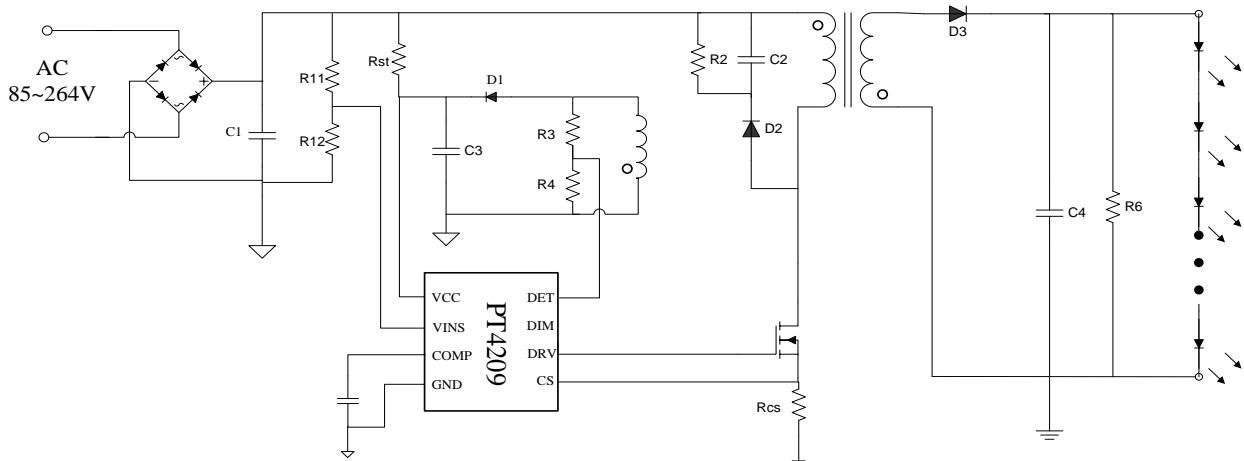

PIN ASSIGNMENT

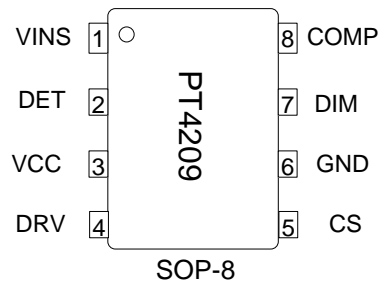

PIN DESCRIPTIONS

PIN No.	PIN NAMES	DESCRIPTION
1	VINS	One of the input pin of the internal multiplier.
2	DET	Auxiliary winding voltage sense pin to detect the moment of zero current of secondary winding, and over voltage.
3	VCC	Power supply pin for all internal circuit.
4	DRV	External MOSFET gate driver pin
5	CS	Primary winding current sensing pin
6	GND	Ground
7	DIM	PWM dimming and analog dimming control pin
8	COMP	Compensation pin for constant current control loop

ABSOLUTE MAXIMUM RATINGS (note1)

SYM	PARAMETER	VALUE	UNIT
V_{CC}	V_{CC} DC Supply Voltage	30	V
V_{VCC_Clamp}	V_{CC} Clamp Voltage	31	V
I_{VCC_Clamp}	V_{CC} DC Clamp Current	10	mA
I_{DET_MAX}	Max DET Pin Current	-50-10	mA
I_{DRV_MAX}	Max DRV Pin Current	1.2	A
V_{DRV}	DRV Pin Voltage Range	-0.3~31	V
V_{CS}	CS Pin Voltage Range	-0.3~31	V
$V_{I/O}$	Other I/O PIN Input Voltage	-0.3~7	V
T_{OPT}	Operating Temp. Range	-40 to 125	°C
T_{STG}	Storage Temp. Range	-55 to 150	°C
$R\theta_{JA}$	SOP8	184	°C/W
HBM	ESD Capability, HBM (note2)	2000	V

RECOMMENDED OPERATING CONDITION

SYMBOL	PARAMETER	VALUE	UNIT
V _{CC}	supply voltage	10 to 23.5	V
T _{OPT}	Operating ambient temperature	-40 to +85	°C

Note 1: Absolute Maximum Ratings indicate limits beyond which damage to the device may occur. Recommended Operating Range indicates conditions for which the device is functional, but do not guarantee specific performance limits. Electrical Characteristics state DC and AC electrical specifications under particular test conditions which guarantee specific performance limits. This assumes that the device is within the Operating Range. Specifications are not guaranteed for parameters where no limit is given, however, the typical value is a good indication of device performance.

Note 2: Human body model, 100pF discharged through a 1.5kΩ resistor.

ELECTRICAL CHARACTERISTICS

(T_A=25°C, V_{CC}=14V, unless specified otherwise)

SYMBOL	PARAMETER	TEST CONDITION	MIN	TYP	MAX	UNIT
Supply Voltage & Current (VCC)						
V _{VCC_ON}	VCC voltage to turn on the chip	VCC Rising	13.5	15	16.5	V
V _{VCC_OFF}	VCC minimum operating level	VCC Falling	7.5	8.5	9.5	V
V _{VCC_OVP}	VCC Over Voltage Protection	VCC Rising	24	26	28	V
V _{VCC_OVP_HYS}	VCC Over Voltage Protection Hysteresis			1.3		V
V _{VCC_Clamp}	VCC Clamp Voltage	I _{CC} =10mA		31		V
I _{Startup}	Start up Current	VCC=11V		10	30	uA
I _{VCC_QUIET}	VCC Supply Current (No Switching)			1	2	mA
I _{VCC_OPER}	VCC Supply Current (During Working)	F _{DRV_AVG} =70KHz, C _{DRV} =1nF		2	5	mA
Multiplier						
V _{VINS_RANG}	VINS Operation Range		0		3	V
K	Multiplier Gain (note3)		0.5	0.6	0.8	
Error Amplifier						
V _{Ref}	Reference voltage for constant current control		0.392	0.4	0.408	V
G _{EA}	Transconductance			35		uA/V

V _{COMP_RANG}	COMP Operation Range		0.8		5	V
Current Sense						
T _{LEB}	Leading edge blanking time			280		ns
V _{CS_Clamp}	Current sense clamp voltage		1.8	2.0	2.2	V
V _{CS_PROT}	Vcs protection trigger voltage		4.1	4.5	4.9	V
DET Pin Sense						
V _{ZCD}	Zero current detect threshold voltage	Falling edge		0		V
V _{ZCD_H}	Zero current detect hysteretic voltage			1.4		V
V _{DET_OVP}	DET over-voltage threshold	1us delay after turn-off	3.6	4	4.4	V
T _{OFF_MIN}	Minimum off time			5		uS
T _{Start}	Start timer period	DET pin voltage no more than 0.35V when switch off		50		us
DIM Set Pin						
V _{DIM}	DIM floating voltage		5.5	6	6.5	V
V _{DIMH}	DIM input logic high level		2.4			V
V _{DIML}	DIM input logic low level				0.7	V
V _{DIM_DC}	DIM input analog dim range		0.7		2.4	V
I _{DIM}	DIM pull up current	V _{DIM} =0V		20		uA
DRV OUTPUT						
V _{DRV_Clamp}	DRV clamp voltage		11	14	17	V
I _{DRV_Source}	Max DRV source current			1		A
I _{DRV_Sink}	Max DRV sink current			-1.2		A
PROTECTION						
T _{SD}	Thermal Shut Down Threshold			150		°C

Note 3: The multiplier output is given by: $V_{CS}=K \cdot V_{VINS} \cdot (V_{COMP}-0.8)$

Typical Performance Characteristics

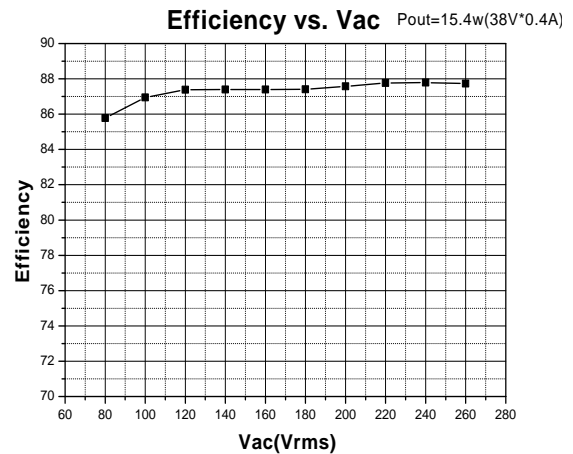
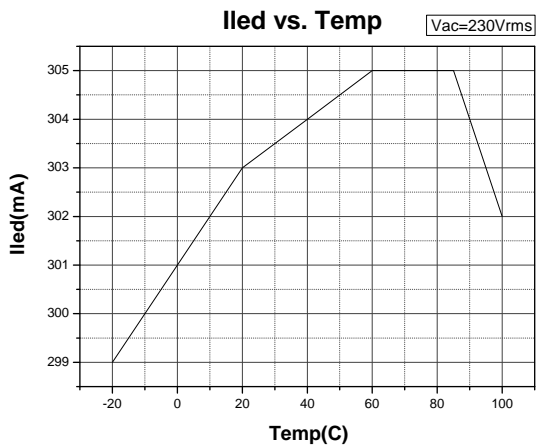
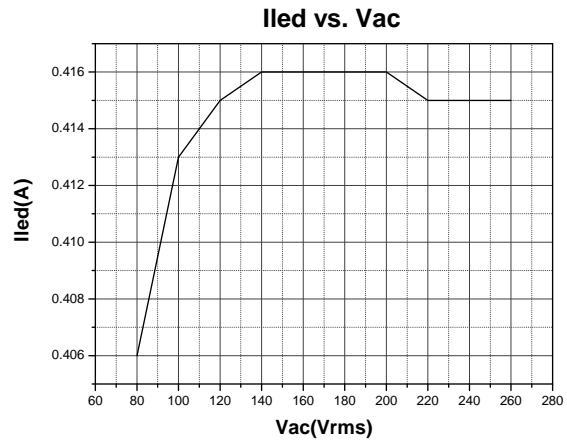
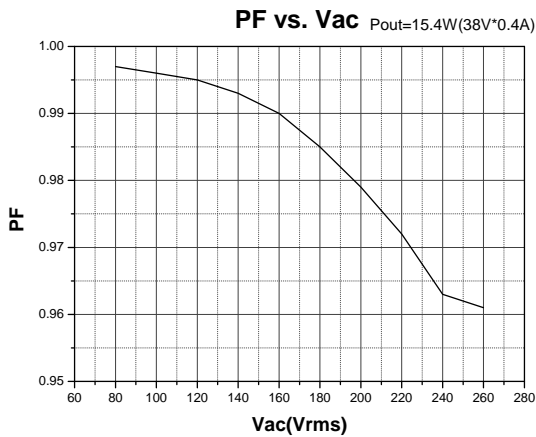
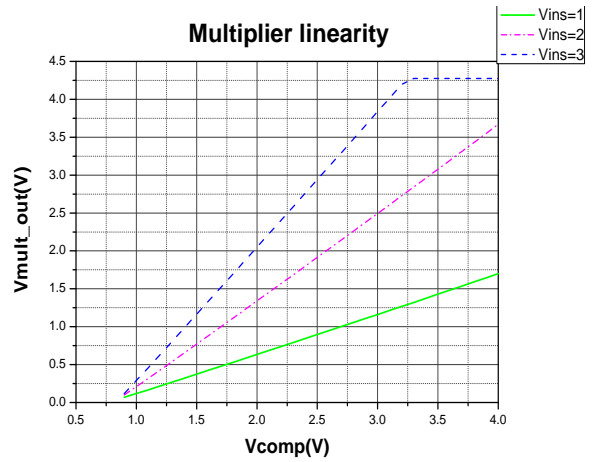
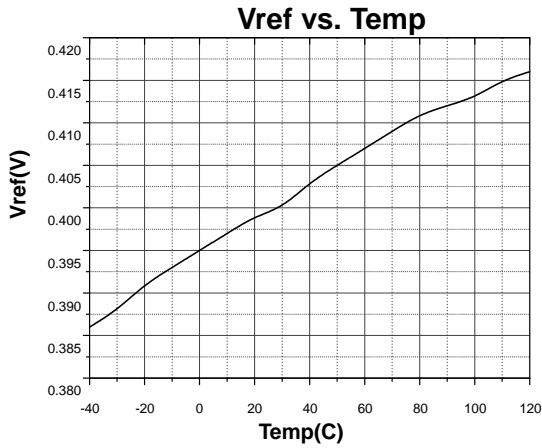

Startup
Vin=90V Load=16*1W

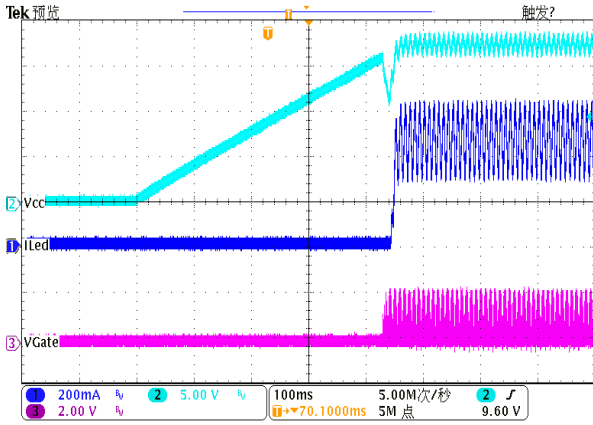

Quasi-Resonant Switching
Vin=90V Load=16*1W

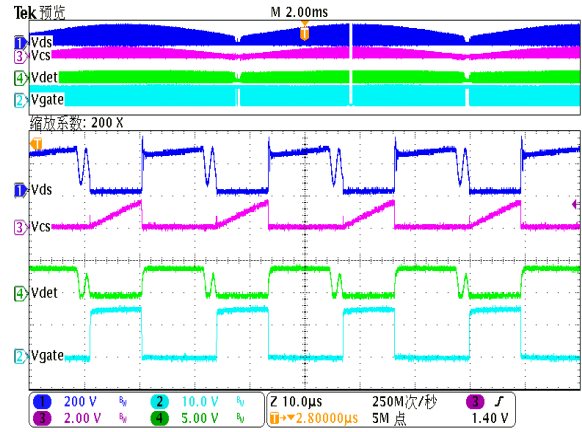

Output Short Protection
Vin=90V Load=16*1W

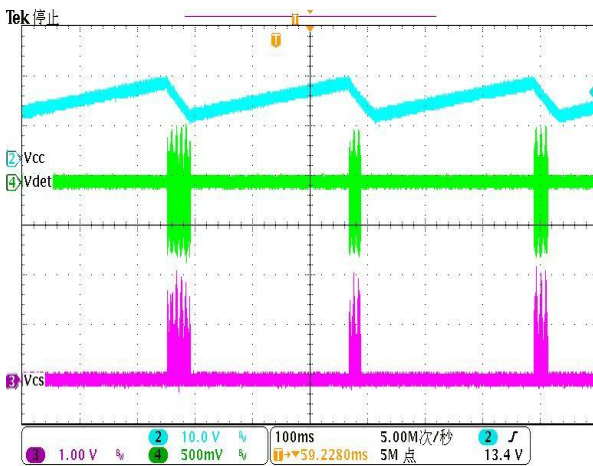

Output Open Protection
Vin=90V Load=16*1W

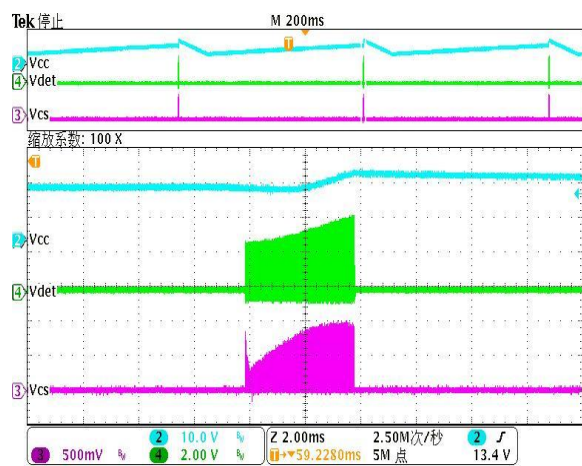

SIMPLIFIED BLOCK DIAGRAM

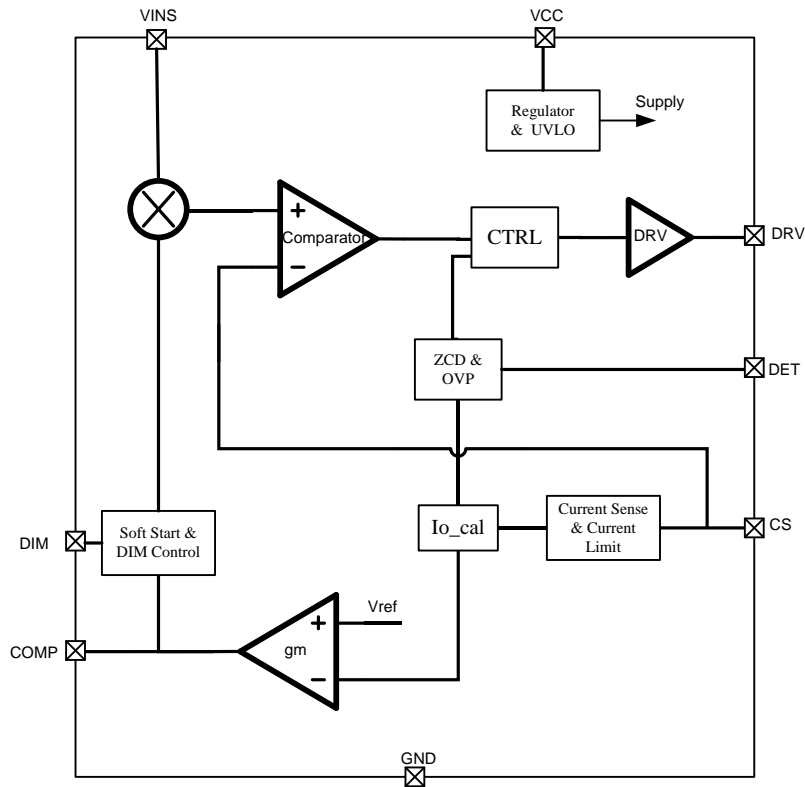

Functional description

The PT4209 is a flicker-free PWM/analog dimmable, primary side constant current controller which can achieve high power factor in a single stage converter, targeted to applications in solid state lighting. It is designed for the flyback topology, and regulates output current accurately without the secondary feedback loop.

PT4209 works in quasi-resonant mode to reduce the MOSFET switching loss. The device use extremely low start up current and low quiescent current to achieve high efficiency.

A complete set of integrated protection functions allows the PT4209 to protect against all fault conditions such as VCC under-voltage, VCC over-voltage, cycle by cycle current limit, output open/short circuit, Rcs open circuit, transformer winding short circuit and over temperature shut down.

Startup

VCC is the power supply terminal for the PT4209.

Once the AC voltage is applied to the application circuit, the V_{bus} charges the VCC pin up through the start up resistor R_{st} . When the voltage of VCC exceeds the threshold of V_{VCC_ON} , the controller starts to deliver driving pulses to power MOS and VCC is powered by auxiliary winding.

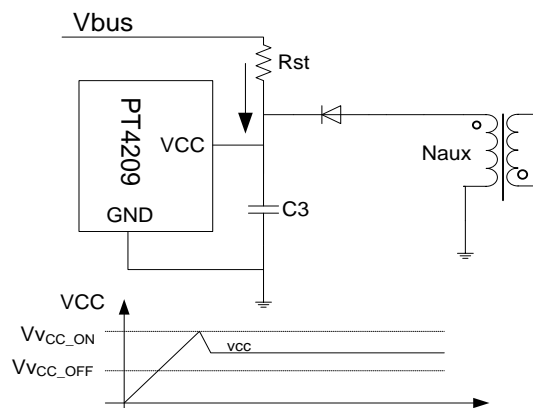

Thanks to the very small start up current, a large start up resistor could be used in the start up circuit to minimize power loss. The maximum voltage VCC pin is clamped by internal Zener diode.

Output Current Setting

Output current can be set by the following equation.

$$I_O = \frac{1}{2} \cdot \frac{V_{ref}}{R_{CS}} \cdot N_{PS} \cdot \eta$$

where V_{ref} is the chip internal reference voltage which is 400mV, R_{CS} is the primary side current sensing resistor, N_{PS} is the ratio of primary side winding turns to the secondary side of transformer, η is the efficiency of transformer.

Single-Stage PFC

PT4209 uses a high-linearity, wide input/output voltage range multiplier to achieve high PF and low input current harmonic. It has two input node. One input VINS pin is used to sense Input sinusoidal reference; another input COMP is the output of error amplifier within constant-current loop, its voltage can represent output current level. They are multiplied to be CS voltage reference. By this control strategy, input average current is a sinusoidal shape synchronous with input voltage.

Quasi-Resonant Mode

PT4209 works in quasi-resonant mode for to reduce the power MOS switching loss. To detect a more accurate T_{dis} (secondary side current discharging time), power MOS will switch on at the second bottom point of the SW waveform (at the drain side of the power MOS) after the power MOS turning off.

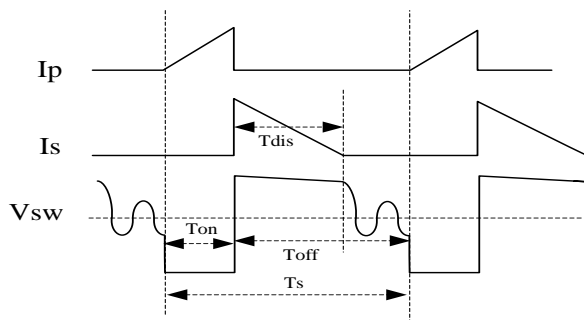

PWM Dimming Control

PT4209 detects PWM dimming signal through DIM pin. And the PWM signal(10%-100%) will be used to modulate internal reference voltage which is used for output current control. The dimming signal's frequency is preferred to be larger than 20 kHz to avoid audible noise.

Analog Dimming Control

Analog dimming signal can be detected through DIM pin. And the analog dimming signal will be transferred to PWM signal whose duty circle will be proportional to analog dimming signal's voltage value. And this internal PWM signal will be used to modulate internal reference which is used for output current control as PWM dimming control.

Current Limit

The current limit circuit senses the current in the power MOS. When this current exceeds the internal threshold, the power MOS turns off for the rest of that cycle.

Short Circuit Protection

During the output short circuit period, the power MOS will switch at frequency of about 20 kHz and CS is clamped at 0.8V to reduce short-circuit state power dissipation, and there will be no current charge to the VCC capacitor, and VCC voltage will fall to V_{vcc_off} threshold voltage. Under this condition, the controller enters hiccup mode operation. This hiccup behavior will continue until the short circuit condition is removed.

VCC Over Voltage Protection

The controller includes a VCC over-voltage protection circuitry, which will turn off the power MOS if the VCC pin voltage is above 26V so that VCC pin voltage will stop rising in fault condition. When VCC pin voltage falls to 1.4V below 26V, power MOS switching will return to normal operation.

Output Over Voltage Protection

Output over-voltage protection circuitry will shut down the IC when the feedback pin DET voltage is above 4V for 3 consecutive switching cycles. In this condition, the controller enters hiccup mode operation. The hiccup

behavior will continue until the output over voltage condition is removed.

Rcs Open Circuit Protection

When Rcs is disconnected from the ground side, the controller will detect high voltage on CS pin after power MOS on. If CS pin voltage is larger than the internal threshold, the IC will shut down. Under this condition, the controller will enter a hiccup mode operation. The hiccup behavior will continue until the Rcs open circuit condition is removed.

Transformer Winding Short Circuit Protection

When one of transformer windings is shorted, no matter it's a primary-side winding or a second-side winding, main power loop acts as a conduction line, high voltage will appear at the node of CS. Once CS voltage is larger than 4.5V, the device will shut down immediately and

avoid any damage to the power loop devices. Under this condition, the controller will enter a hiccup mode operation. This hiccup behavior will continue until transformer windings short circuit condition is removed.

Over Temperature Protection

The thermal shutdown circuitry senses the junction temperature of the die. If the junction temperature exceeds 150 °C, the device will shut down and enter a hiccup mode operation.

PACKAGE INFORMATION

SOP8

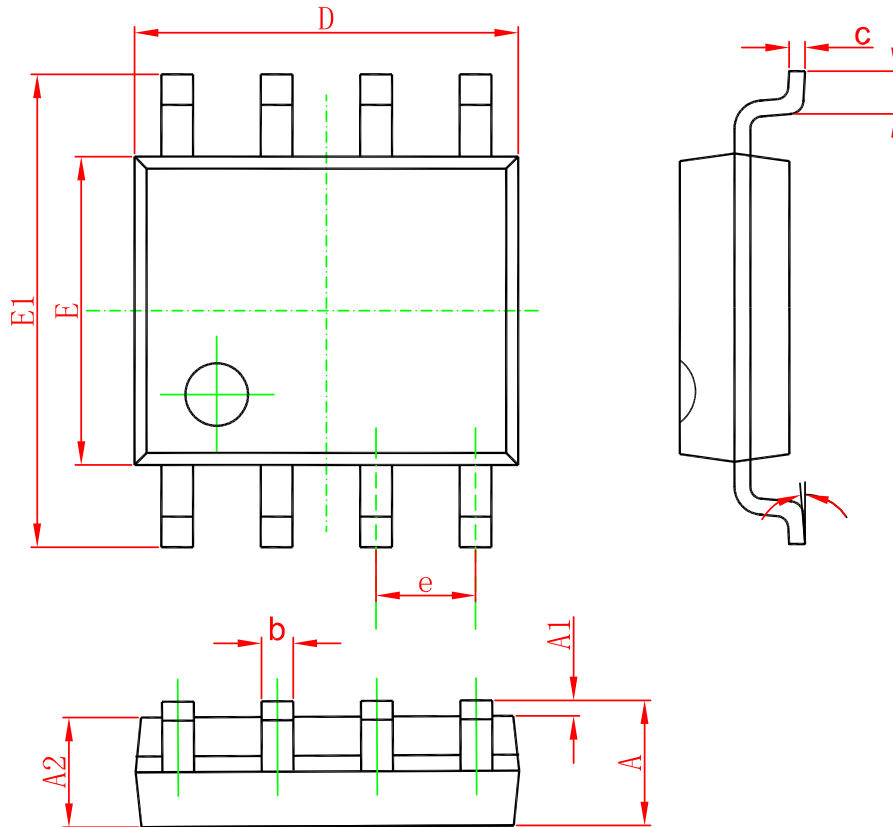

SYMBOL	DIMENSIONS IN MILLIMETERS		DIMENSIONS IN INCH	
	MIN	MAX	MIN	MAX
A	1.350	1.750	0.053	0.069
A1	0.100	0.250	0.004	0.010
A2	1.350	1.550	0.053	0.061
b	0.330	0.510	0.013	0.020
c	0.170	0.250	0.006	0.010
D	4.700	5.100	0.185	0.200
E	3.800	4.000	0.150	0.157
E1	5.800	6.200	0.228	0.244
e	1.270(BSC)		0.050(BSC)	
L	0.400	1.270	0.016	0.050
θ	0°	8°	0°	8°